



**SPAN CPT7
Installation and Operation
User Manual**

SPAN CPT7 Installation and Operation User Manual

Publication Number: OM-20000179

Revision Level: v7

Revision Date: January 2020

Firmware Version: 7.07.03 / OM7MR0703RN0000, SC7PR0304RN0000

Warranty

NovAtel Inc. warrants that its GNSS products are free from defects in materials and workmanship, subject to the conditions set forth on our web site: www.novatel.com/products/warranty/ and for the following time periods:

OEM7 [®] Receivers	One (1) Year
GNSS Antenna Series	One (1) Year
Cables and Accessories	Ninety (90) Days
Software Warranty	One (1) Year

Return instructions

To return products, refer to the instructions found at: www.novatel.com/warranty-return.

Proprietary Notice

Information in this document is subject to change without notice and does not represent a commitment on the part of NovAtel Inc. The software described in this document is furnished under a licence agreement or non-disclosure agreement. The software may be used or copied only in accordance with the terms of the agreement. It is against the law to copy the software on any medium except as specifically allowed in the license or non-disclosure agreement.

No part of this manual may be reproduced or transmitted in any form or by any means, electronic or mechanical, including photocopying and recording, for any purpose without the express written permission of a duly authorized representative of NovAtel Inc.

The information contained within this manual is believed to be true and correct at the time of publication.

NovAtel, ALIGN, GLIDE, GrafNav/GrafNet, Inertial Explorer, NovAtel CORRECT, OEM7, PwrPak7, RELAY, SPAN, STEADYLINE, VEXXIS and Waypoint are registered trademarks of NovAtel Inc.

NovAtel Connect, OEM719, OEM729, OEM7500, OEM7600, OEM7700, OEM7720, SMART7, SMART2, RELAY7 and RTK ASSIST are trademarks of NovAtel Inc.

All other brand names are trademarks of their respective holders.

© Copyright 2020 NovAtel Inc. All rights reserved. Unpublished rights reserved under International copyright laws.

Table of Contents

Figures

Tables

SPAN CPT7 Notices

Customer Support

Chapter 1 SPAN CPT7 Overview

1.1 SPAN CPT7 Connectors	20
1.2 Fundamentals of GNSS+INS	20

Chapter 2 SPAN CPT7 Installation

2.1 Shipping Box	22
2.2 Additional Equipment Required	22
2.3 Optional Accessories	22
2.4 SPAN CPT7 Cables	23
2.5 Selecting a GNSS Antenna	23
2.6 Choosing a Coaxial Cable	24
2.7 Power Supply Requirements for the SPAN CPT7	24
2.8 SPAN CPT7 Installation Overview	25
2.9 Mounting the GNSS Antenna	26
2.9.1 Antenna LNA Power	26
2.10 Mount the SPAN CPT7	27
2.10.1 Securing the SPAN CPT7	27
2.10.2 Secure the SPAN CPT7 Using the Adapter Plate	28
2.11 Connect the SPAN CPT7 to Data Communication Equipment	31
2.11.1 Serial Ports	31
2.11.2 USB Ports	32
2.11.3 Ethernet Port	32
2.11.4 CAN Bus Port	32
2.12 Connect I/O Signals to the SPAN CPT7	33
2.13 Connect Power to the SPAN CPT7	33
2.13.1 Fuse for the Power Supply	33
2.13.2 Vehicle Installation	34
2.14 Check that the SPAN CPT7 is Operating	35

Chapter 3 OEM7 Receiver Operation

3.1 Communications with the Receiver	36
3.1.1 USB Communications	37
3.1.2 Serial Port Communications	37
3.1.3 Ethernet Communications	39
3.1.4 ICOM Communications	39

3.1.5 CAN Bus Communications	39
3.2 Getting Started	40
3.2.1 Communicating with the Receiver	40
3.3 Transmitting and Receiving Corrections	41
3.3.1 Defining Antenna and Base Antenna	42
3.3.2 Base Station Configuration	42
3.3.3 Rover Station Configuration	43
3.3.4 Configuration Notes	44
3.4 GLIDE	44
3.4.1 Dual-Frequency GLIDE	45
3.4.2 PDP and GLIDE Configurations	45
3.5 STEADYLINE	45
3.5.1 Prefer Accuracy	46
3.6 Enabling SBAS Positioning	46
3.7 Enabling PPP	47
3.7.1 TerraStar Subscriptions	47
3.7.2 Veripos Subscriptions	49
3.8 RTK ASSIST	49
3.9 Transferring Time Between Receivers	50
3.9.1 GPS to Receiver Time Synchronization	50
3.9.2 Time Definitions	50
3.9.3 Procedures to Transfer Time	51
3.10 Interference Toolkit	55
3.10.1 Monitoring GNSS Signals	55
3.10.2 Disable/Enable Detection	56
3.10.3 Monitoring Signals Using a Command Line	57
3.10.4 Monitoring Signals Using NovAtel Connect	58
3.10.5 Remove Interference Signals	59
3.11 Logging and Retrieving Data Overview	62
3.11.1 Pass-Through Logging	62
3.12 Additional Features and Information	62
3.12.1 Strobes	62

Chapter 4 SPAN Operation

4.1 Definition of Reference Frames Within SPAN	63
4.1.1 The Local-Level Frame (ENU)	63
4.1.2 The IMU Body Frame	64
4.1.3 The Vehicle Frame	65
4.1.4 The User Output Frame	65
4.2 SPAN Translations and Rotations	65
4.2.1 Translational Offsets	66
4.2.2 Rotational Offsets	67
4.3 Software Configuration	69
4.3.1 GNSS Configuration	69
4.3.2 INS Profiles	69
4.3.3 SPAN Configuration for SPAN CPT7	70
4.3.4 Importance of RBV Calibration	73

4.4	Real-Time Operation	75
4.4.1	System Start-Up and Alignment Techniques	76
4.4.2	INS Seed / Fast INS Initialization	78
4.4.3	Navigation Mode	80
4.4.4	Data Collection	80
4.4.5	Body to Vehicle Frame Rotation Calibration Routine	82
4.4.6	Multi-Line Body to Vehicle Frame Rotation Calibration Routine	82
4.5	Synchronizing External Equipment	84
4.5.1	Configuring an Input Strobe	84
4.6	Adding Timed Sensor Triggers	85
4.6.1	Configuring the Hardware	85
4.6.2	Configuring the Software	85
4.6.3	Using Timed Event Pulses	86
4.6.4	Recording Incoming Sensor Events	86
4.7	Azimuth Sources on a SPAN System	86
4.7.1	Course Over Ground	86
4.7.2	Inertial Azimuth	86
4.7.3	ALIGN Azimuth	87
4.8	Data Collection for Post Processing	87
4.9	Variable Lever Arm	88
4.9.1	Reference Frame Description	88
4.9.2	How to Use Variable Lever Arm	91
4.10	Relative INS	93
4.10.1	Configure Relative INS	94

Chapter 5 SPAN CPT7 with Dual Antenna

5.1	Configuring ALIGN with SPAN	96
5.1.1	Configuring SPAN with ALIGN	97
5.1.2	Alignment on a Moving Vessel - Aided Transfer Alignment	97
5.1.3	Alignment on a Stationary Vehicle - Aided Static Alignment	97
5.1.4	Unaided Alignment	97
5.1.5	Automatic Alignment Mode - Automatic Alignment (default)	98
5.2	SPAN ALIGN Attitude Updates	98

Chapter 6 Ethernet Configuration

6.1	Required Hardware	99
6.2	Static IP Address Configuration	99
6.2.1	Static IP Address Configuration—Receiver	100
6.2.2	Static IP Address Configuration—Windows 7	101
6.2.3	Confirming Ethernet Setup	102
6.3	Dynamic IP Address Configuration	102
6.4	Base/Rover Configuration through Ethernet Connectivity	103
6.5	Large Ethernet Port Data Throughput	105

Chapter 7 NTRIP Configuration

7.1	NTRIP Configuration Over Ethernet	106
-----	---	-----

Chapter 8 CAN Bus

8.1	Default Configuration	109
8.2	Configuring the CAN Bus	109
8.2.1	Configuration Notes	109
8.2.2	Example of Enabling the CAN Bus	110
8.2.3	Example of Modifying the CAN Bus Parameters	110
8.2.4	Example of Detecting an Address Claim Failure and Reconfiguring	110
8.2.5	Address Claim Procedure	110
8.3	NMEA2000 Logging	111
8.3.1	Example of NMEA2000 Log Configuration	111
8.4	Corrections Over CAN	111
8.4.1	Example for Receiving Corrections from Any Source	112
8.4.2	Example for Transmitting Corrections to 0x1C Node	112
8.5	NovAtel Messages Over CAN	112
8.6	Configuring OEM7 Receivers to Use OEM6 CAN Settings	113
8.6.1	Configuration on OEM6	113
8.6.2	Configuration on OEM7	113

Chapter 9 Built-In Status Tests

9.1	Receiver Status Word	114
9.2	RXSTATUSEVENT Log	114
9.3	RXSTATUS Log	115
9.3.1	Status Word	115
9.3.2	Error Word	115
9.3.3	Status Code Arrays	116
9.3.4	Receiver Status Code	117
9.3.5	Auxiliary Status Codes	117
9.3.6	Set and Clear Mask for all Status Code Arrays	117

Chapter 10 Troubleshooting

10.1	Examining the RXSTATUS Log	119
10.2	Examining the AUX1 Status Word	122
10.3	High Temperature Environments	123
10.3.1	Indicators of an Error State	123
10.3.2	Recovering from a Temperature Status Error	123
10.3.3	Mitigating High Receiver Temperature	123
10.3.4	Monitoring the Receiver Temperature	124
10.4	Safe Mode	125
10.4.1	Reset Loop Detection	125
10.4.2	Recovery Steps	125

Chapter 11 NovAtel Firmware and Software

11.1	Firmware Updates and Model Upgrades	126
11.1.1	Firmware Updates	126
11.1.2	Model Upgrades	126
11.2	Authorization Code	127

11.3	Downloading Firmware Files	127
11.3.1	Format of Firmware Files	128
11.4	Updating or Upgrading Using the WinLoad Utility	128
11.4.1	Using the WinLoad Utility	128
11.5	Updating the Firmware Using NovAtel Connect	130
11.6	Updating the Firmware Using NovAtel Web UI	131
11.7	Updating Using SoftLoad Commands	131
11.7.1	SoftLoad Commands and Logs	132
11.7.2	Working With S-Records	132
11.7.3	Sending Firmware Data	133
11.7.4	SoftLoad Update Method	134
11.7.5	SoftLoad Errors	136
11.8	Upgrading Using an Auth-Code	137
11.8.1	Entering an Auth-Code Using NovAtel Connect	137
11.8.2	Entering an Auth-Code Using NovAtel Web UI	137
11.8.3	Entering an Auth-Code Using the Command Line	137

APPENDIX A SPAN CPT7 Technical Specifications

A.1	SPAN CPT7 Performance Specifications	140
A.2	SPAN CPT7 Mechanical Specifications	143
A.3	SPAN CPT7 Electrical and Environmental Specifications	146
A.4	SPAN CPT7 Data Communication Specifications	148
A.5	SPAN CPT7 Strobe Specifications	149
A.6	SPAN CPT7 Connectors	150
A.7	SPAN CPT7 I/O1 Cable	152
A.7.1	Custom Cable Recommendations	153
A.8	SPAN CPT7 I/O2 Cable	154
A.8.1	Custom Cable Recommendations	155

APPENDIX B Accessories and Replacement Parts

APPENDIX C Frequently Asked Questions

APPENDIX D Importance of Antenna Selection

Figures

Figure 1: SPAN CPT7 Receiver	19
Figure 2: Typical Installation of a SPAN CPT7 System	25
Figure 3: SPAN CPT7 Adapter Plate	29
Figure 4: Offset from the SPAN CPT7 to the SPAN-CPT	30
Figure 5: Offset from the SPAN CPT7 to the SPAN-IGM-S1	31
Figure 6: Fuse for PwrPak7 Power Supply	34
Figure 7: Dedicated Battery for the SPAN CPT7	35
Figure 8: Basic SPAN CPT7 Connection Interfaces (example)	36
Figure 9: Basic Differential Setup	41
Figure 10: Positioning Change Without STEADYLINE	46
Figure 11: STEADYLINE Prefer Accuracy	46
Figure 12: Transfer COARSE Time from Fine Clock to Cold Clock Receiver	52
Figure 13: Transfer FINE Time from Fine Clock to Cold Clock Receiver	53
Figure 14: Transfer FINE Time from Fine Clock to Warm Clock Receiver	54
Figure 15: 1 PPS Alignment	54
Figure 16: Local-Level Frame (ENU)	64
Figure 17: IMU Body Frame Marking	64
Figure 18: Vehicle Frame	65
Figure 19: IMU to Antenna Translation Offset	66
Figure 20: Rear View of SPAN CPT7 – Mounting Plate is not Flat	74
Figure 21: Side View of SPAN CPT7 – Vehicle is not Level	74
Figure 22: Top View of SPAN CPT7 – SPAN CPT7 Misalignment	74
Figure 23: Multi-Line IMU Body to Vehicle Calibration	83
Figure 24: Sample Configuration	90
Figure 25: Operating Gimbal	91
Figure 26: Relative INS Example	94
Figure 27: Cross-Over Ethernet Cable Configuration—OEM7 Receiver	100
Figure 28: Dynamic IP Address Configuration through a DHCP Server—OEM7 Receiver	102
Figure 29: Base/Rover Ethernet Setup—OEM7 Receiver	104
Figure 30: NTRIP System	106
Figure 31: Location of Receiver Status Word	115
Figure 32: Reading the Bits in the Receiver Status Word	115
Figure 33: Location of Receiver Error Word	116
Figure 34: Reading the Bits in the Receiver Error Word	116
Figure 35: Status Code Arrays	117

Figure 36: WinLoad's Open Window	129
Figure 37: Open File in WinLoad	129
Figure 38: COM Port Setup	130
Figure 39: SPAN CPT7 Dimensions	144
Figure 40: SPAN CPT7 Center of Navigation	145
Figure 41: Fischer Core 16 Pin Connector	150
Figure 42: SPAN CPT7 I/O1 Cable	152
Figure 43: SPAN CPT7 I/O2 Cable	154
Figure 44: Plot of Good and Poor Antenna Phase Center Variation over Elevation Angle 0-90°	160

Tables

Table 1: SPAN CPT7 Connectors	20
Table 2: SPAN CPT7 Cables	23
Table 3: Fuse/Holder Recommendations 12 V System	34
Table 4: Serial Ports Supported	38
Table 5: OEM7 INS Profiles	69
Table 6: Inertial Solution Status	75
Table 7: NVM Seed Indication	80
Table 8: Solution Parameters	80
Table 9: Valid Event Inputs and Outputs for Timed Sensor Triggers	85
Table 10: Logs with Azimuth Data	87
Table 11: Logs used with Variable Lever Arm	92
Table 12: Commands used with Variable Lever Arm	92
Table 13: Default NAME	109
Table 14: Troubleshooting Based on Symptoms	118
Table 15: Resolving a Receiver Error Word	119
Table 16: Resolving an Error in the Receiver Status Word	121
Table 17: Resolving an Error in the AUX1 Status Word	122
Table 18: SPAN CPT7 Physical Description	139
Table 19: SPAN CPT7 Receiver Performance	140
Table 20: SPAN CPT7 IMU Performance	142
Table 21: SPAN CPT7 Environmental Specifications	146
Table 22: SPAN CPT7 Power Requirements	146
Table 23: SPAN CPT7 RF Input/LNA Power Output	146
Table 24: Data Communications Interfaces	148
Table 25: SPAN CPT7 Strokes Description	149
Table 26: SPAN CPT7 Strobe Electrical Specifications	149
Table 27: IO1 Pin Out	150
Table 28: IO2 Pin Out	151
Table 29: SPAN CPT7 I/O1 Cable Pinout	152
Table 30: I/O1 Connector	153
Table 31: SPAN CPT7 I/O2 Cable Pinout	154
Table 32: IO2 Connector	155
Table 33: GNSS Antennas	156
Table 34: SPAN CPT7 Cables	156
Table 35: GNSS Antenna Cables	157

Table 36: SPAN CPT7 Mounting Accessories157

SPAN CPT7 Notices

The following notices apply to the SPAN CPT7.



Changes or modifications to this equipment, not expressly approved by NovAtel Inc., could void the user's authority to operate this equipment.

FCC

The devices covered by this manual comply with part 15 of the FCC Rules. Operation is subject to the following two conditions: (1) this device may not cause harmful interference, and (2) this device must accept any interference received, including interference that may cause undesired operation.

The equipment listed has been tested and found to comply with the limits for a Class B digital device, pursuant to part 15 of the FCC Rules. The Class B limits are designed to provide reasonable protection against harmful interference in a residential installation. The equipment listed generates, uses, and can radiate radio frequency energy and, if not installed and used in accordance with the instructions, may cause harmful interference to radio communications. However, there is no guarantee that interference will not occur in a particular installation. If this equipment does cause harmful interference to radio or television reception, which can be determined by turning the equipment off and on, the user is encouraged to try to correct the interference by one or more of the following measures:

- Reorient or relocate the receiving antenna
- Increase the separation between the equipment and the receiver
- Connect the equipment to an outlet on a circuit different from that to which the receiver is connected
- Consult the dealer or an experienced radio/TV technician for help

Innovation, Science and Economic Development (ISED) Canada

SPAN CPT7 Class B digital device complies with Canadian ICES-003.

SPAN CPT7 appareils numérique de la classe B sont conforme à la norme NMB-003 du Canada.

This device complies with ISED license-exempt RSS-GEN and RSS-247. Operation is subject to the following two conditions: (1) this device may not cause interference and (2) this device must accept any interference, including interference that may cause undesired operation of the device.

Cet appareil est conforme à la norme ISED RSS-GEN et RSS-247. Son fonctionnement est soumis aux deux conditions suivantes: (1) cet appareil ne doit pas provoquer d'interférences et (2) cet appareil doit accepter toute interférence, y compris les interférences pouvant entraîner un fonctionnement indésirable de l'appareil.

European Union (EU)

Hereby, NovAtel Inc. declares that the radio equipment type SPAN CPT7 GNSS receiver is in compliance with Directive 2014/53/EU

The full text of the EU Declaration of Conformity may be obtained from the NovAtel website at: www.novatel.com/products/compliance/eu-declaration-of-conformity/.

WEEE

If you purchased your SPAN CPT7 in Europe, please return it to your dealer or supplier at the end of life. The objectives of the European Community's environment policy are, in particular, to preserve, protect and improve

the quality of the environment, protect human health and utilise natural resources prudently and rationally. Sustainable development advocates the reduction of wasteful consumption of natural resources and the prevention of pollution. Waste Electrical and Electronic Equipment (WEEE) is a regulated area. Where the generation of waste cannot be avoided, it should be reused or recovered for its material or energy. WEEE products may be

recognized by their wheeled bin label ()

See www.novatel.com/products/compliance/environmental-compliance/ for more information.

RoHS

SPAN CPT7 GNSS receivers are in conformity with Directive 2011/65/EU of the European Parliament and of the Council of 8 June 2011 on the restriction of the use of certain hazardous substances in electrical and electronic equipment.

REACH

SPAN CPT7 receivers are in compliance with Regulation (EC) No 1907/2006 OF THE EUROPEAN PARLIAMENT AND THE COUNCIL of 18 December 2006 concerning the Registration, Evaluation, Authorization and Restriction of Chemicals (REACH). The Candidate List of Substances of Very High Concern (SVHC) published by the European Chemical Agency (ECHA) is available at <https://echa.europa.eu/candidate-list-table>.

EAC

Декларация о соответствии ТР ТС 020/2011 ЕАЭС № RU Д-СА.АД78.В.01856/18 от 13.12.2018, действительна по 12.12.2023, зарегистрирована органом по сертификации общества с ограниченной ответственностью «ЕАЭС РЕШЕНИЕ».

(English translation: Declaration of Conformity Based on Technical Regulation of Customs Union 020/2011 No. ЕАЭС № RU Д-СА.АД78.В.01856/18 valid from 13.12.2018 until 12.12.2023, registered by Certification Body "EAEU SOLUTION".)

Instructions for Safe Operation of Equipment



The SPAN CPT7 is capable of operation at ambient temperatures up to 65°C. In such cases, the metallic surface temperature of the SPAN CPT7 may exceed 70°C. Therefore, under these conditions the equipment needs to be installed in a RESTRICTED ACCESS LOCATION.

If the SPAN CPT7 is operating in a lower temperature environment where the ambient temperature is less than 60°C, installation in a RESTRICTED ACCESS LOCATION is not required.

Lightning Protection Installation and Grounding Procedure

What is the hazard?

A lightning strike into the ground causes an increase in the earth's potential which results in a high voltage potential between the center conductor and shield of the coaxial cable. This high voltage develops because the voltage surge induced onto the center conductor lags in time behind the voltage surge induced onto the shield.

Hazard Impact

A lightning strike causes the ground potential in the area to rise to dangerous levels resulting in harm to personnel or destruction of electronic equipment in an unprotected environment. It also conducts a portion of the strike energy down the inner conductor of the coaxial cable to the connected equipment.



Only qualified personnel, such as electricians mandated by the governing body in the country of installation, may install lightning protection devices.

Actions to Mitigate Lightning Hazards

1. Do not install antennas or antenna coaxial cables outside the building during a lightning storm.
2. It is not possible to avoid over voltages caused by lightning, but a lightning protection device may be used to shunt a large portion of the transient energy to the building ground, reducing the over voltage condition as quickly as possible.
3. Primary lightning protection must be provided by the operator/customer according to local building codes as part of the extra building installation.
4. To ensure safe operation, a secondary lightning protection device must be used for in-building equipment installations with external antennas. The following device has been approved by NovAtel Inc.:

Polyphaser - Surge Arrestor DGXZ+36NFNF-A

If this device is not chosen as the primary lightning protection device, the device chosen must:

- Be UL listed (or equivalent) in the country of installation for lightning surge protection
 - The primary device must be capable of limiting an incoming surge to 10 kV
5. The shield of the coaxial cable entering the building should be connected at a grounding plate at the building's entrance. The lightning protection devices should have their chassis grounded to the same ground near to the building's entrance.
 6. The primary and secondary lightning protections should be as close to the building's entrance as possible. Where feasible, mount onto the grounding plate itself (refer to the figure below).

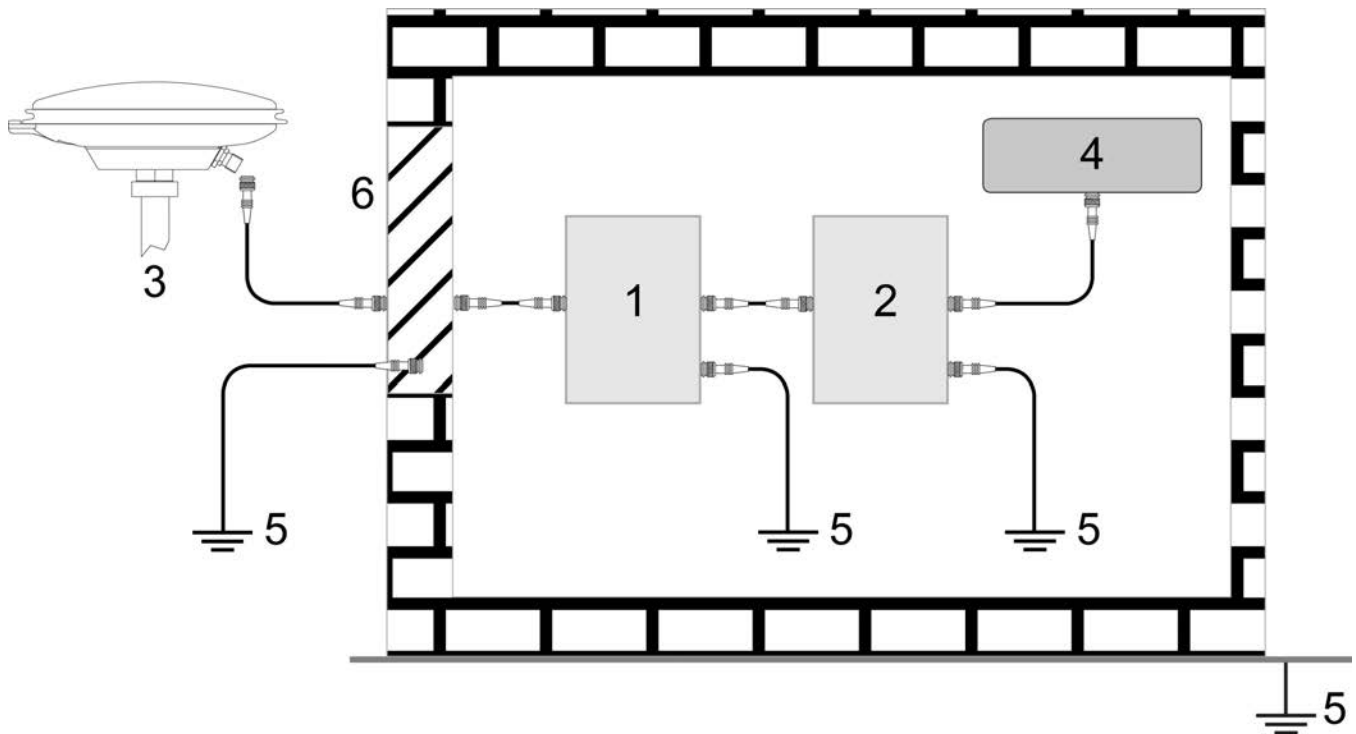

Ref #	Description
1	Primary lightning protection device
2	Secondary lightning protection device
3	External antenna
4	GNSS Receiver
5	To ground
6	Grounding plate or grounding point at the building's entrance



Acceptable choices for earth grounds, for central buildings, are:

- Grounded interior metal cold water pipe within five feet (1.5 m) of the point where it enters the building
- Grounded metallic service raceway
- Grounded electrical service equipment enclosure
- Eight-foot grounding rod driven into the ground (only if bonded to the central building ground by #6, or heavier, bonding wire)

These installation instructions are the minimum requirements for receiver and antenna installations. Where applicable, follow the electrical codes for the country of installation. Examples of country codes include:

- **USA** National Electrical Code (NFPA 70)
- **Canada** Canadian Electrical Code (CSA C22.1)
- **UK** British Standard (BS7671)

Ethernet Port



The Ethernet port is a safety extra-low voltage (SELV) circuit only and is suitable for connection within a building only. Do not connect them to Telecommunications Network Voltage (TNV) circuits.

Conventions

The following conventions are used in this manual:



Information that supplements or clarifies text.



A caution that actions, operation or configuration may lead to incorrect or improper use of the hardware.



A warning that actions, operation or configuration may result in regulatory noncompliance, safety issues or equipment damage.

Customer Support

NovAtel Knowledge Base

If you have a technical issue, visit the NovAtel Support page at www.novatel.com/support. Through the *Support* page, you can contact Customer Support, find papers and tutorials or download current manuals and the latest firmware.

Before Contacting Customer Support

Before contacting NovAtel Customer Support about a software problem, perform the following steps:



If logging data over an RS-232 serial cable, ensure that the configured baud rate can support the data bandwidth (see **SERIALCONFIG** command). NovAtel recommends a minimum suggested baud rate of 230400 bps.

1. Log the following data to a file on your computer for 15 minutes:

```
LOG RXSTATUSB onchanged
LOG ALMANACB onchanged
LOG RAWEPHEMB onchanged
LOG GLORAWEPHEMB onchanged
LOG TRACKSTATB ontime 1
LOG SATVIS2B ontime 60
LOG BESTPOSB ontime 1
LOG RANGE B ontime 1
LOG RXCONFIGA once
LOG ITDETECTSTATUSB onchanged
LOG VERSIONA once
LOG PORTSTATSB ontime 10
```

For SPAN systems, add the following logs to the above list in the file created on your computer:

```
LOG RAWIMUSXB onnew
LOG INSUPDATESTATUSB onnew
LOG INSPVAXB ontime 1
LOG INSCONFIGA onchanged
```

For issues with tracking L-Band or TerraStar (PPP) convergence, add the following logs to the above list in the file created on your computer:

```
LOG IONUTCB onchanged
LOG GLOCLOCKB onchanged
LOG PPPPOSB ontime 1
LOG PPPSATSB ontime 1
LOG LBANDTRACKSTATB ontime 1
LOG TERRASTARINFOA onchanged
LOG TERRASTARSTATUSA onchanged
LOG LBANDBEAMTABLEA onchanged
```

2. Send the data file to NovAtel Customer Support: support@novatel.com
3. You can also issue a **FRESET** command to the receiver to clear any unknown settings.



The **FRESET** command will erase all user settings. You should know your configuration (by requesting the RXCONFIGA log) and be able to reconfigure the receiver before you send the **FRESET** command.

If you are having a hardware problem, send a list of the troubleshooting steps taken and the results.

Contact Information

Log a support request with NovAtel Customer Support using one of the following methods:

Log a Case and Search Knowledge:

Website: www.novatel.com/support

Log a Case, Search Knowledge and View Your Case History: (login access required)

Web Portal: <https://novatelsupport.force.com/community/login>

E-mail:

support@novatel.com

Telephone:

U.S. and Canada: 1-800-NOVATEL (1-800-668-2835)

International: +1-403-295-4900

Chapter 1 SPAN CPT7 Overview

NovAtel's Synchronous Position, Attitude and Navigation (SPAN[®]) technology brings together two very different but complementary positioning and navigation systems namely Global Navigation Satellite System (GNSS) and an Inertial Navigation System (INS). By combining the best aspects of GNSS and INS into one system, SPAN technology is able to offer a solution that is more accurate and reliable than either GNSS or INS could provide alone. The combined GNSS+INS solution has the advantage of the absolute accuracy available from GNSS and the continuity of INS through traditionally difficult GNSS conditions.

NovAtel's SPAN CPT7 is a scalable, high precision GNSS+INS receiver in a lightweight, compact, environmentally protective enclosure. The SPAN CPT7 provides the following features:

- Multi-frequency/Multi-constellation
- 555 channel operation
- Dual antenna inputs for single enclosure ALIGN heading solution
- SPAN GNSS+INS functionality
- Two serial communication ports, 1 RS-422 and 1 RS-232
- One USB communication port
- One Ethernet communication port
- One CAN bus port
- 2 Event outputs
- 2 Event inputs
- PPP, RTK, SBAS and DGPS positioning solutions
- GLIDE and ALIGN positioning options
- Enhanced interference mitigation

Figure 1: SPAN CPT7 Receiver





SPAN CPT7 technical specifications are provided in *SPAN CPT7 Technical Specifications* on page 139.

1.1 SPAN CPT7 Connectors

The SPAN CPT7 has several connectors for connecting the receiver to other components in the GNSS system.

Table 1: SPAN CPT7 Connectors

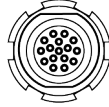
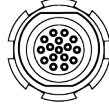
Connector	Label	Description
	RF1	SMA connector for the primary GNSS antenna
	RF2	SMA connector for the secondary GNSS antenna
	IO1	16-pin circular connector <ul style="list-style-type: none"> • Power • 7720-COM2 (RS-422) • EVENT_IN 1 • EVENT_OUT 1
	IO2	16-pin circular connector <ul style="list-style-type: none"> • Power • 7720-COM1 (RS-232) • USB • Ethernet • CAN bus • EVENT_IN 2 • EVENT_OUT 2

1.2 Fundamentals of GNSS+INS

GNSS positioning observes range measurements from orbiting GNSS satellites. From these observations, the receiver can compute position and velocity with high accuracy. NovAtel GNSS positioning systems are highly accurate positioning tools. However, GNSS in general has some restrictions which limit its usefulness in some situations. GNSS positioning requires line of sight view to at least four satellites simultaneously. If these criteria are met, differential GNSS positioning can be accurate to within a few centimeters. If however, some or all of the satellite signals are blocked, the accuracy of the position reported by GNSS degrades substantially, or may not be available at all.

In general, an INS uses forces and rotations measured by an IMU to calculate position, velocity and attitude. This capability is embedded in the firmware of OEM7 receivers. Forces are measured by accelerometers in three perpendicular axes within the IMU and the gyros measure angular rotation rates around those axes. Over short periods of time, inertial navigation gives very accurate acceleration, velocity and attitude output. The INS must have prior knowledge of its initial position, initial velocity, initial attitude, Earth rotation rate and gravity field. Since the IMU measures changes in orientation and acceleration, the INS determines changes in position and attitude, but initial values for these parameters must be provided from an external source. Once these parameters are known, an INS is capable of providing an autonomous solution with no external inputs. However, because of errors in the IMU measurements that accumulate over time, an inertial-only solution degrades with time unless external updates such as position, velocity or attitude are supplied.

The SPAN system's combined GNSS+INS solution integrates the raw inertial measurements with all available GNSS information to provide the optimum solution possible in any situation. By using the high accuracy GNSS solution, the IMU errors can be modeled and mitigated. Conversely, the continuity and relative accuracy of the INS solution enables faster GNSS signal reacquisition and RTK solution convergence.

The advantages of using SPAN technology are its ability to:

- Provide a full attitude solution (roll, pitch and azimuth)
- Provide continuous solution output (in situations when a GNSS-only solution is impossible)
- Provide faster signal reacquisition and RTK solution resolution (over stand-alone GNSS because of the tightly integrated GNSS and INS filters)
- Output high-rate (up to the IMU data rate depending on your logging selections) position, velocity and attitude solutions for high-dynamic applications, see also *Logging Restriction Important Notice* on page 81
- Use raw phase observation data (to constrain INS solution drift even when too few satellites are available for a full GNSS solution)



For more information about GNSS and INS, refer to www.novatel.com/an-introduction-to-gnss/

Chapter 2 SPAN CPT7 Installation

This chapter provides instructions to install the SPAN CPT7 and create a GNSS+INS system.

2.1 Shipping Box

The following is provided with the SPAN CPT7:

- SPAN CPT7 I/O1 Cable (01020208)
- SPAN CPT7 I/O2 Cable (01020209)
- SPAN CPT7 Quick Start Guide (GM-14915154)



The SPAN CPT7 I/O cables are not included with SPAN CPT7 NC models.

2.2 Additional Equipment Required

The following additional equipment is required for a typical SPAN CPT7 system:

- A 9-32 VDC, fuse protected power supply capable of at least 18 W
- Two high quality GNSS antennas, such as NovAtel's VEXXIS® GNSS-500 or GNSS-800 series antennas
For a list of NovAtel GNSS antennas, refer to www.novatel.com/antennas
- Two antenna cables with an SMA male connector at the SPAN CPT7 end
- Four #6 size screws for mounting
- A computer with a serial COM, USB or Ethernet port

The following equipment may also be needed, depending on the system configuration:

- Shielded Ethernet cable



Use a serial COM or USB connection to communicate with the receiver first. This provides the ability to configure the computer and SPAN CPT7 before using Ethernet.



When the SPAN CPT7 is installed in a permanent location, such as in a building, it should be protected by a lightning protection device according to local building codes. See *Lightning Protection Installation and Grounding Procedure* on page 14.

2.3 Optional Accessories

The following optional accessory is available from NovAtel:

- SPAN CPT7 Adapter Plate (01020112)
This plate mounts on the SPAN CPT7 and provides SPAN-CPT and SPAN-IGM compatible mounting holes. See *Secure the SPAN CPT7 Using the Adapter Plate* on page 28.

2.4 SPAN CPT7 Cables

To prevent damage to both the receiver and the cables, each connector can be inserted in only one way. Also, the IO1 and IO2 connectors are keyed so that the cable can only be inserted in the connector for which it is intended.

Furthermore, the connectors used to mate the cables to the receiver require careful insertion and removal. The cables for IO1 and IO2 use push/pull connectors. The cables for RF1 and RF2 use threaded connectors. Observe the following when handling cables.

- Make certain to use the appropriate cable for the SPAN CPT7 connector
- Insert the connector until it is on straight and secure
- To remove a cable, grasp it by the connector



Do not pull directly on a cable.

Table 2: SPAN CPT7 Cables

NovAtel Part Number	Cable Name	Purpose
01020208	<i>SPAN CPT7 I/O1 Cable on page 152</i>	Provides connection to: <ul style="list-style-type: none"> • External power supply • COM2 serial port (RS-422) • Event In 1 • Event Out 1
01020209	<i>SPAN CPT7 I/O2 Cable on page 154</i>	Provides connection to: <ul style="list-style-type: none"> • External power supply (alternate power connection option) • COM1 serial port (RS-232) • USB port • Ethernet port • Event In 2 • Event Out 2

2.5 Selecting a GNSS Antenna

NovAtel offers a variety of GNSS antennas, including single, dual and triple-frequency, triple-band and wide-band reference antennas (refer to our web site: www.novatel.com/antennas for details of available antennas). All antennas include band pass filtering and an LNA. The GNSS antenna chosen depends on the particular application. Each model offers exceptional phase center stability and a significant measure of immunity against multipath interference. Each antenna has an environmentally sealed radome and all meet the European Union's Restriction of Hazardous Substances (RoHS) and Waste Electrical and Electronic Equipment (WEEE).

If a non-NovAtel GNSS antenna is chosen, a typical antenna LNA gain between 26 dB to 30 dB is recommended in a rover station application.



A dual frequency capable GNSS antenna is required to use SPAN, RTK, ALIGN or dual frequency GLIDE.
An L-Band capable antenna is required to receive TerraStar corrections.

For more information about antenna selection, see *Importance of Antenna Selection* on page 159.

2.6 Choosing a Coaxial Cable

An appropriate coaxial cable matches the impedances of the antenna and receiver (50 ohms) and has a line loss not exceeding 10.0 dB. If the limit is exceeded, excessive signal degradation may occur and the receiver may not meet performance specifications. NovAtel offers several coaxial cables to meet GNSS antenna inter-connection requirements, including:

- 5 m, 15 m and 30 m antenna cable with TNC connectors on both ends (NovAtel part numbers GPS-C006, GPS-C016 and GPS-C032)
- 2.5 m and 5 m antenna cable with an SMA connector on one end and a TNC connector on the other (NovAtel part numbers 60723177 and 60723178)

The SPAN CPT7 requires cables with an SMA connector on the receiver side or an SMA to TNC adapter.



The SMA to TNC cables (60723177 and 60723178) are not recommended for permanent outdoor use.



For more information about antenna cabling, including using cables longer than 30 m and in-line amplifiers, refer to APN-077: RF Equipment Selection and Installation available from (www.novatel.com/assets/Documents/Bulletins/APN-077-RFEquipmentSelection.pdf).



NovAtel recommends using high quality coaxial cables because an impedance mismatch is possible when using lower quality cables and this produces reflections in the cable that increases signal loss. Although other high quality antenna cables can be used, the performance specifications of the OEM7 receivers are warranted only when used with NovAtel supplied accessories.

2.7 Power Supply Requirements for the SPAN CPT7

The SPAN CPT7 requires a power supply that provides:

- a voltage in the range of +9 to +32 VDC
- at least 18 W of power (peak)

See *SPAN CPT7 Electrical and Environmental Specifications* on page 146 for more power supply specifications.



If the voltage supplied is below the minimum specification, the receiver suspends operation. If the voltage supplied is above the maximum specification, the receiver may be permanently damaged, voiding the warranty.

The supply must be capable of providing enough current to operate the SPAN CPT7, including the initial inrush transient. The supply must also be current limited to 8 A with an external fuse.



The amount of power required depends on the number of constellations and signals tracked, and the features enabled.



Power can be connected to **either** the IO1 or IO2 port.
Do not connect a power supply to both ports.

2.8 SPAN CPT7 Installation Overview

A SPAN CPT7 system consists of a SPAN CPT7, a GNSS antenna, power and a communication link (if your application requires real time differential operation). The following diagram shows a typical SPAN CPT7 installation.

Figure 2: Typical Installation of a SPAN CPT7 System

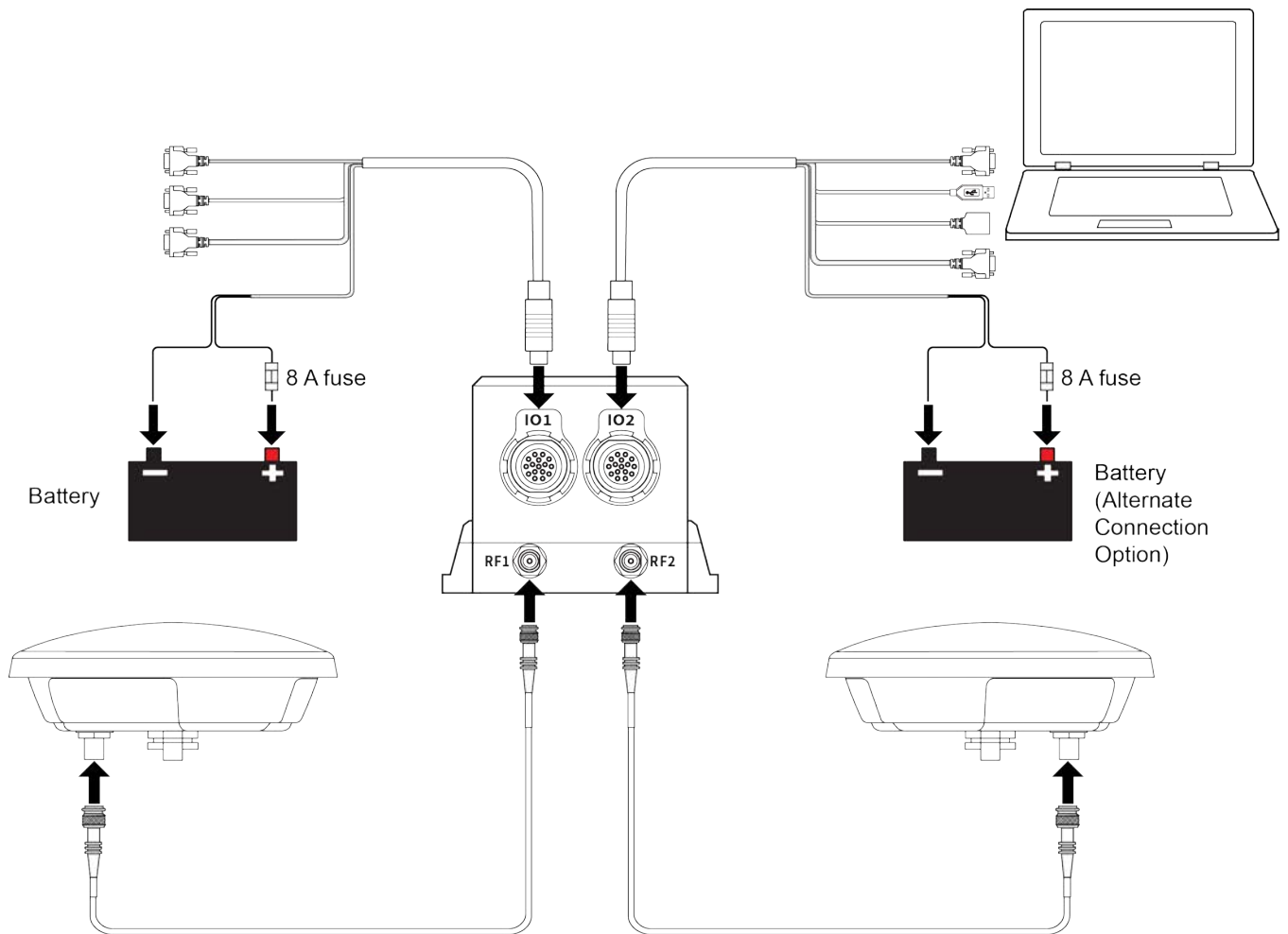

Power can be connected to **either** the IO1 or IO2 port.
Do not connect a power supply to both ports.

Complete the following steps to set up your SPAN CPT7 system.

1. Mount the GNSS antenna.
See *Mounting the GNSS Antenna* below for details.
2. Mount the SPAN CPT7.
See *Mount the SPAN CPT7* on the next page for details.
3. Connect the primary GNSS antenna to the RF1 port on the SPAN CPT7.
Connect the secondary GNSS antenna to the RF2 port on the SPAN CPT7.
The SPAN CPT7 supplies +5 VDC (200 mA maximum) to the antenna LNA through the center conductor of the antenna cable. See *Antenna LNA Power* below for more information.
4. Connect the I/O strobe signals (optional).
See *Connect I/O Signals to the SPAN CPT7* on page 33 for details.
5. Connect power to the SPAN CPT7.
See *Connect Power to the SPAN CPT7* on page 33 for details.
6. Connect a data communication device, such a computer, to the SPAN CPT7. A data communication device is used to configure and monitor the receiver.
See *Connect the SPAN CPT7 to Data Communication Equipment* on page 31 for details.

2.9 Mounting the GNSS Antenna

The SPAN CPT7 is designed to operate with any NovAtel GNSS antenna. See *Selecting a GNSS Antenna* on page 23 for more information.

When installing the antenna:

- Choose an antenna location with a clear view of the sky so each satellite above the horizon can be tracked without obstruction. For more information on RF signal propagation and multipath, refer to the NovAtel application note [APN-008 Discussions on RF Signal Propagation and Multipath](#) at www.novatel.com/support/.
- Mount the antenna on a secure, stable structure capable of safe operation in the specific environment.
- Ensure the antenna cannot move due to dynamics.
- For dual antenna systems only
Heading accuracy is dependent on antenna baseline length. Mount the primary and secondary antennas as far apart as possible. A minimum separation distance of 1 meter is recommended.

For more detailed information about GNSS antenna installation, refer to [APN-077: RF Equipment Selection and Installation for OEM7](#) at www.novatel.com/support/.

2.9.1 Antenna LNA Power

NovAtel antennas and coaxial cables meet receiver RF input gain requirements. NovAtel coaxial cables are designed to introduce no more than 10 dB loss and NovAtel antennas are equipped with built-in LNAs that provide 29 dB of gain to the satellite signal received.

The power to the antenna LNA is provided through the receiver's RF port center conductor.

OEM7 receivers, except the OEM7600, provide +5 VDC $\pm 5\%$ at a maximum of 200 mA. The OEM7600 provides +3.3 VDC $\pm 5\%$ at a maximum of 100 mA.

Antenna supply over current protection limits the LNA power.



If a short circuit or other problem causes an overload of the current supplied to the antenna, the receiver hardware shuts down the power supplied to the antenna. To restore power, power cycle the receiver. The Receiver Status word, available in the **RXSTATUS** log (see [OEM7 Commands and Logs Reference Manual](#)), provides more information about the cause of the problem.

2.10 Mount the SPAN CPT7

Mount the SPAN CPT7 in a fixed location where the distance from the SPAN CPT7 to the phase center of the GNSS antennas is constant. Ensure that the orientation with respect to the vehicle and antennas is also constant.

For the simplest operation, align the X-axis of the SPAN CPT7 with the forward axis (direction of travel) of the vehicle and mount the Z-axis down. When mounted with X-axis forward, the default RBV configuration is valid. Any other mounting requires a rotational offset to be applied. See *Rotational Offsets* on page 67 for more information.



The X, Y and Z axis are marked on the SPAN CPT7 enclosure.

Also, it is important to measure the distance from the SPAN CPT7 to the primary and secondary GNSS antennas (the Antenna Lever Arms), on the first usage, on the axis defined on the SPAN CPT7 enclosure. See also *SPAN CPT7 Mechanical Specifications* on page 143 for dimensional drawings of the SPAN CPT7.

Ensure the SPAN CPT7 cannot move due to dynamics and that the distance and relative direction between the SPAN CPT7 and both antennas is fixed. See *SPAN Configuration for SPAN CPT7* on page 70.



The closer the antennas are to the SPAN CPT7, particularly in the horizontal plane, the more accurate the position solution.

Also, your measurements entered using the **SETINSTRANSLATION** command must be as accurate as possible, or at least more accurate than the GNSS positions being used. **For example, a 10 cm error in recording the antenna offset will result in at least a 10 cm error in the output. Millimeter accuracy is preferred.**

The offset from the SPAN CPT7 to the antennas, and/or a user point device, must remain constant especially for RTK or DGNSS data. Ensure the SPAN CPT7, antenna and user point device are bolted in one position perhaps by using a custom bracket.

2.10.1 Securing the SPAN CPT7

The SPAN CPT7 can be secured directly to the mounting surface or can be secured using the SPAN CPT7 Adapter Plate (01020112).

To secure the SPAN CPT7 directly to the mounting surface, use four #6 screws that pass through the mounting holes in the SPAN CPT7 and into the mounting surface. For the location and spacing of the mounting holes, refer to the mechanical drawings in *SPAN CPT7 Mechanical Specifications* on page 143.



The mounting screws should be torqued to 42 to 45 in-lbs.

For information about securing the SPAN CPT7 using the adapter plate, refer to *Secure the SPAN CPT7 Using the Adapter Plate* on the next page.

2.10.2 Secure the SPAN CPT7 Using the Adapter Plate

The SPAN CPT7 Adapter Plate (01020112) allows the SPAN CPT7 to be installed using the mounting hole spacing designed for the SPAN-CPT or SPAN-IGM-A1/S1.

To secure a SPAN CPT7 using the Adapter Plate:

1. Place the SPAN CPT7 on the Adapter Plate and align the mounting hole on the SPAN CPT7 with the threaded holes in the Adapter Plate.
2. Secure the SPAN CPT7 to the Adapter Plate using the four screws (#6 - 32) included with the mounting plate.
3. Secure the Adapter Plate to the mounting location using 4 screws.
See *Figure 3: SPAN CPT7 Adapter Plate* on the next page for the adapter plate dimensions and mounting hole locations.
4. If the SPAN CPT7 is replacing a SPAN-CPT or SPAN-IGM-S1, see *Figure 4: Offset from the SPAN CPT7 to the SPAN-CPT* on page 30 or *Figure 5: Offset from the SPAN CPT7 to the SPAN-IGM-S1* on page 31 for the offset of the center of navigation of the previous system to the center of navigation of the SPAN CPT7.

Figure 3: SPAN CPT7 Adapter Plate

Dimensions are in mm

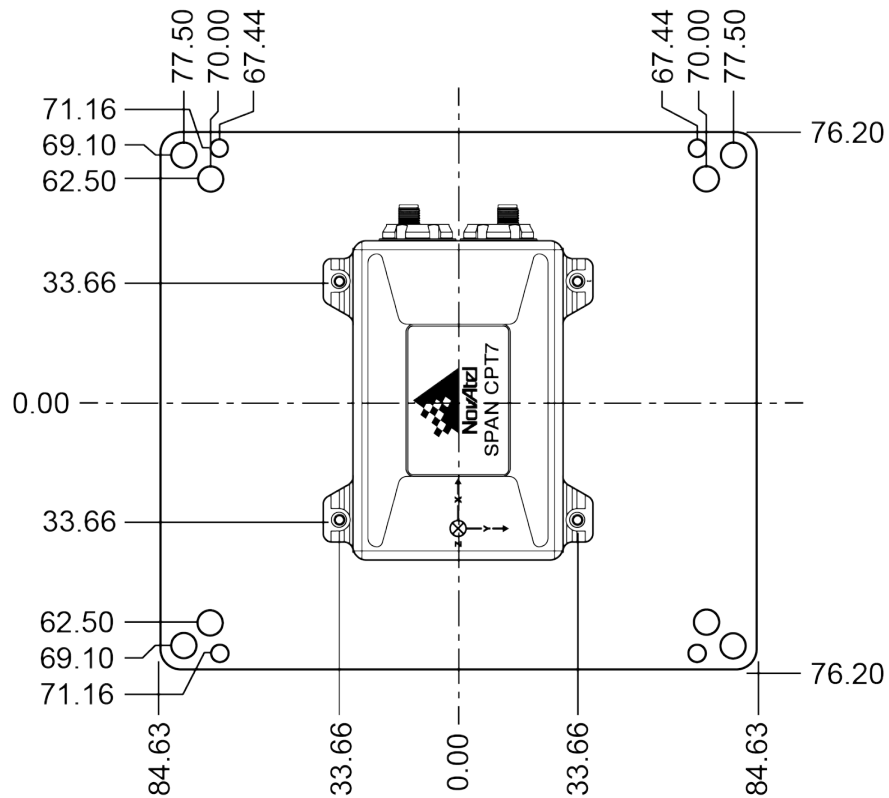
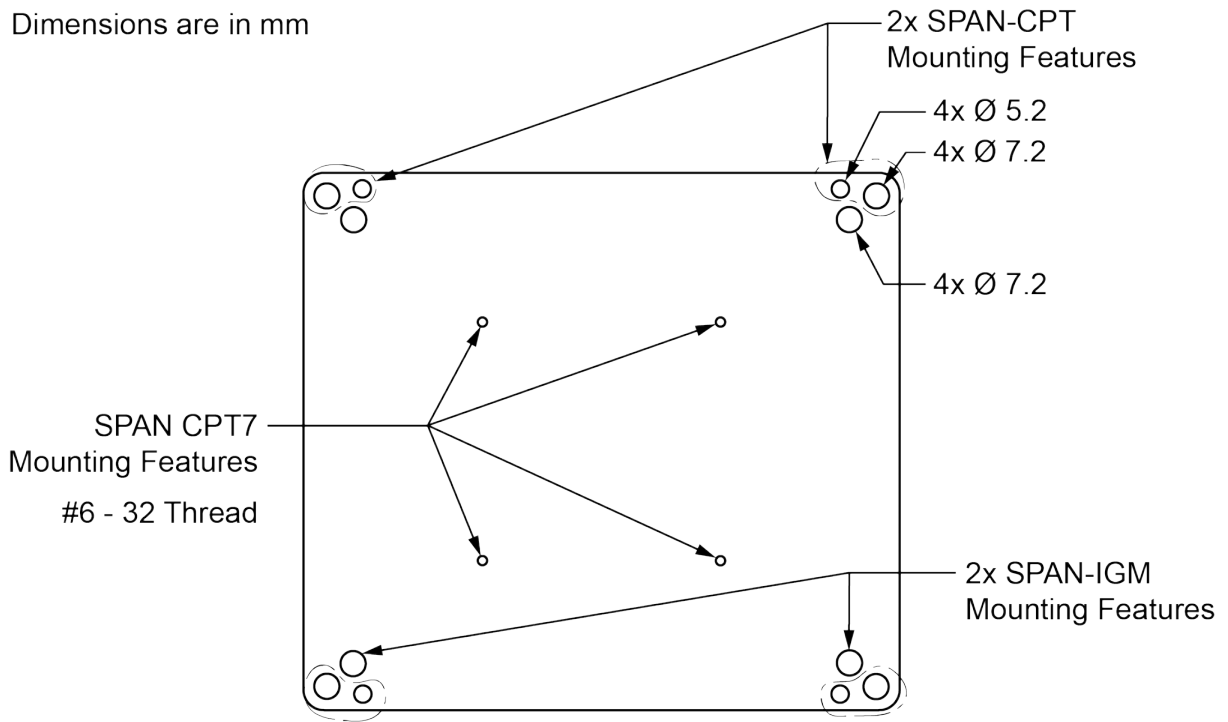
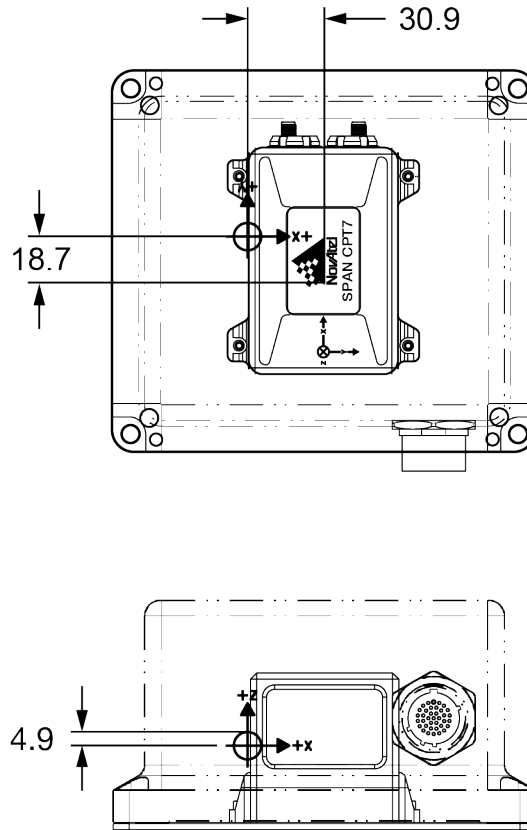

Figure 4: Offset from the SPAN CPT7 to the SPAN-CPT



Dimensions are in mm.

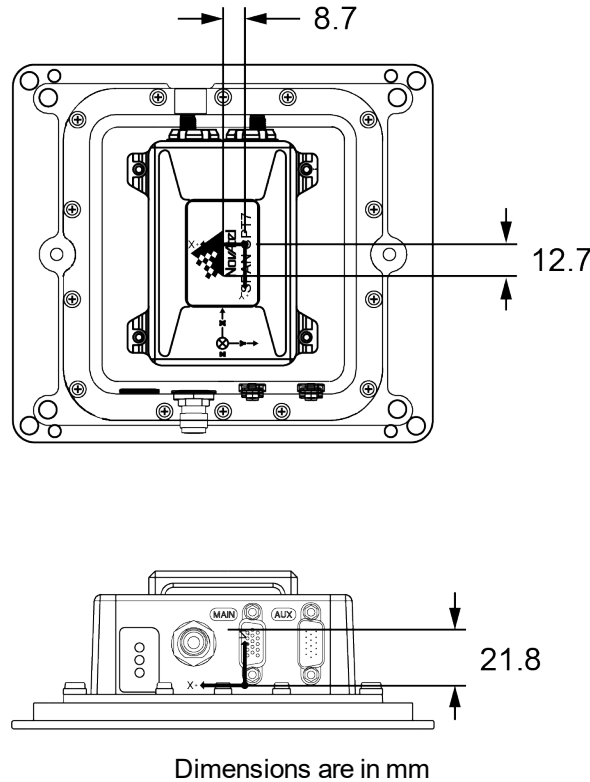

The axis marking on the SPAN CPT7 indicates the orientation of the X, Y and Z axis only. It does not indicate the center of navigation. For the location of the center of navigation, refer to *Figure 40: SPAN CPT7 Center of Navigation* on page 145.

Figure 5: Offset from the SPAN CPT7 to the SPAN-IGM-S1

2.11 Connect the SPAN CPT7 to Data Communication Equipment

The SPAN CPT7 can communicate with other devices in the system, such as computers and data loggers, using serial, USB or Ethernet ports.

- *Serial Ports* below
- *USB Ports* on the next page
- *Ethernet Port* on the next page
- *CAN Bus Port* on the next page

The SPAN CPT7 also has a CAN bus port for communication with other CAN bus compatible devices. See *CAN Bus Port* on the next page.

All data communication connections can be made using the SPAN CPT7 I/O1 cable (PN: 01020208) or SPAN CPT7 I/O2 cable (PN: 01020209). For information about these two cables, see *SPAN CPT7 I/O1 Cable* on page 152 and *SPAN CPT7 I/O2 Cable* on page 154. These sections also have the connector pin out and connector recommendations for making a custom cable.

2.11.1 Serial Ports

The SPAN CPT7 has two serial ports: COM1 and COM2. COM1 uses RS-232 protocol and is available on the IO2 port. COM2 uses RS-422 protocol and is available on the IO1 port. Refer to *SPAN CPT7 Connectors* on page 150 for the pin out of these connectors.

Port settings (bit rate and parity, for example) are software configurable. See *Communications with the Receiver* on page 36 for information about configuring the serial ports. Also see *SPAN CPT7 Data Communication Specifications* on page 148 for the serial port specifications.

To connect to a serial port using RS-232 protocol:

1. Connect the SPAN CPT7 I/O2 cable, or a custom made cable, to the IO2 connector.
2. Connect the DB9 female connector on the cable to the serial port on the computer or other data communication device.

To connect to a serial port using RS-422 protocol:

1. Connect the SPAN CPT7 I/O1 cable, or a custom made cable, to the IO1 connector.
2. Connect the DB9 female connector on the cable to the serial port on the computer or other data communication device.

2.11.2 USB Ports

The SPAN CPT7 has one USB 2.0 compatible port available on the IO2 connector. This USB port operates at 480 Mb/s.

To connect to the USB port:

1. Connect the SPAN CPT7 I/O2 SPAN cable, or a custom made cable, to the IO2 connector.
2. Connect the USB connector on the SPAN CPT7 I/O2 SPAN cable to a USB port on the computer or other data communication device.

2.11.3 Ethernet Port

The SPAN CPT7 has a 10Base-T/100Base-TX Ethernet on the IO2 connector that can be used for communications with external data communications equipment such as computers and data loggers. The Ethernet port supports IPv4 Internet layer, TCP/IP transport, ping and connection from a Telnet client. Users can conduct remote debugging, accept MRTCA (modified RTCA) data and download firmware. OEM7 receivers are also equipped with NTRIP Version 2.0 (Networked Transport of RTCM via Internet Protocol) client and server capability.

To connect to the Ethernet port:

1. Connect the SPAN CPT7 I/O2 SPAN cable, or a custom made cable, to the IO2 connector.
2. Connect an Ethernet cable from the RJ45 jack on the SPAN CPT7 I/O2 SPAN cable to an Ethernet port on the computer or other data communication device.

Refer to *Ethernet Configuration* on page 99 for instructions on configuring Ethernet and NTRIP.

2.11.4 CAN Bus Port

The SPAN CPT7 has a CAN Bus port available on the IO2 connector.

To connect to the CAN Bus port:

1. Connect the SPAN CPT7 I/O2 SPAN cable, or a custom made cable, to the IO2 connector.
2. Connect the CAN signals, available on the DB15 connector, to the CAN Bus.



The SPAN CPT7 CAN bus port is unterminated. If the SPAN CPT7 is at the end of the bus, then the connecting cable must have 120 ohms integrated into the cable between CANH and CANL in close proximity to the I/O2 connector.

For information about configuring CAN, see *CAN Bus* on page 108.

2.12 Connect I/O Signals to the SPAN CPT7

The SPAN CPT7 has several inputs and outputs, also referred to as strobes, that provide status and synchronization signals.

- Event Inputs
- Event Outputs

For more information about the I/O signals, refer to the *SPAN CPT7 Strobe Specifications* on page 149.

To access the EVENT_IN1 or EVENT_OUT1 signals, connect the SPAN CPT7 I/O1 Cable, or a custom made cable, to the IO1 connector. The Event signals are available on the DB15 connector of the SPAN CPT7 I/O1 cable.

To access the EVENT_IN2 or EVENT_OUT2 signals, connect the SPAN CPT7 I/O2 Cable, or a custom made cable, to the IO2 connector. The Event signals are available on the DB15 connector of the SPAN CPT7 I/O2 cable.

For information about the SPAN CPT7 I/O cables, see *SPAN CPT7 I/O1 Cable* on page 152 or *SPAN CPT7 I/O2 Cable* on page 154. These sections also have the connector pin out and connector recommendations for making a custom cable.

2.13 Connect Power to the SPAN CPT7



Power can be connected to **either** the IO1 or IO2 port.
Do not connect a power supply to both ports.

To connect power to the SPAN CPT7:

1. Connect the SPAN CPT7 IO/1 Cable, SPAN CPT7 I/O2 Cable or a custom made interface cable to the SPAN CPT7. See *SPAN CPT7 I/O1 Cable* on page 152 or *SPAN CPT7 I/O2 Cable* on page 154 for information about these cables.
2. Connect the bare wires of the I/O cable to a 9 to 32 VDC power supply.
For details about the power supply required, see *Power Supply Requirements for the SPAN CPT7* on page 24.





Ensure the VIN line is connected to the positive pole of the power source and the GND line is connected to the negative pole of the power source.

2.13.1 Fuse for the Power Supply

Install a user supplied 8 A slow blow fuse in the positive line of the connection to the power source to protect the power supply wiring and your warranty.

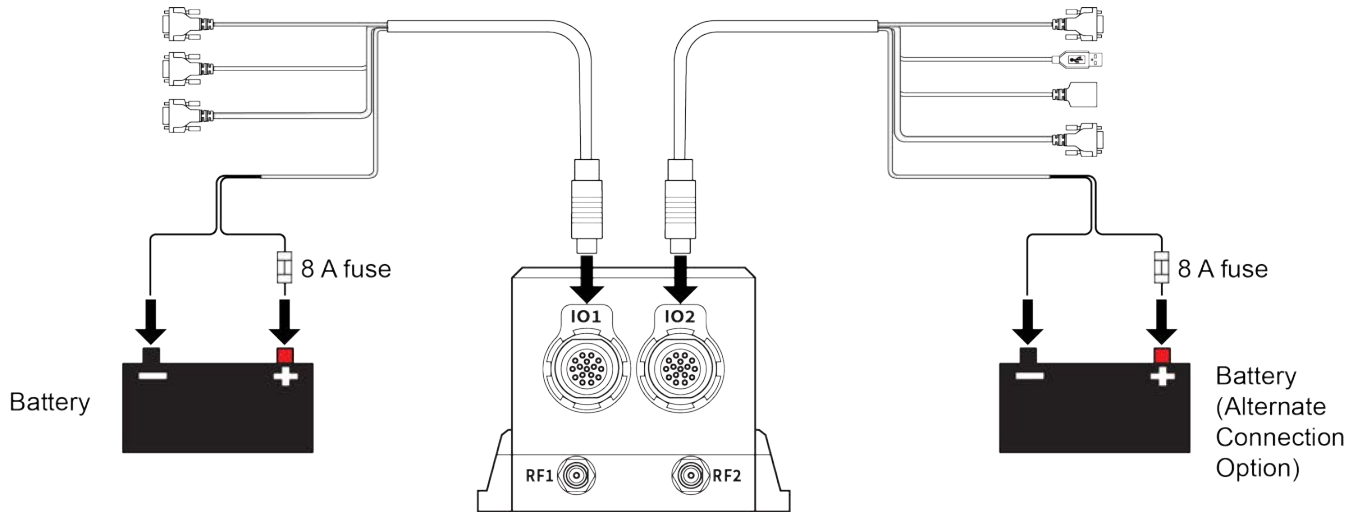
Figure 6: Fuse for PwrPak7 Power Supply



 Power can be connected to **either** the IO1 or IO2 port. **Do not** connect a power supply to both ports.

For a 12 V system, the following are recommended.

Table 3: Fuse/Holder Recommendations 12 V System

Fuse	Holder
BK/MDA-8-R Fuse (or equivalent)	BK/HFA-R Fuse (or equivalent)
BK/MDL-8-R Fuse (or equivalent)	

 The fuse and holder are made by Cooper/Bussmann; available from Digikey.

2.13.2 Vehicle Installation

If the receiver is installed in a vehicle, it is recommended that a dedicated battery be provided for the receiver that is isolated from the engine starter battery. When a vehicle engine is started, the voltage on the starter battery can dip below the SPAN CPT7 minimum voltage or cut-out to ancillary equipment causing the receiver to lose lock and calibration settings.

Figure 7: Dedicated Battery for the SPAN CPT7

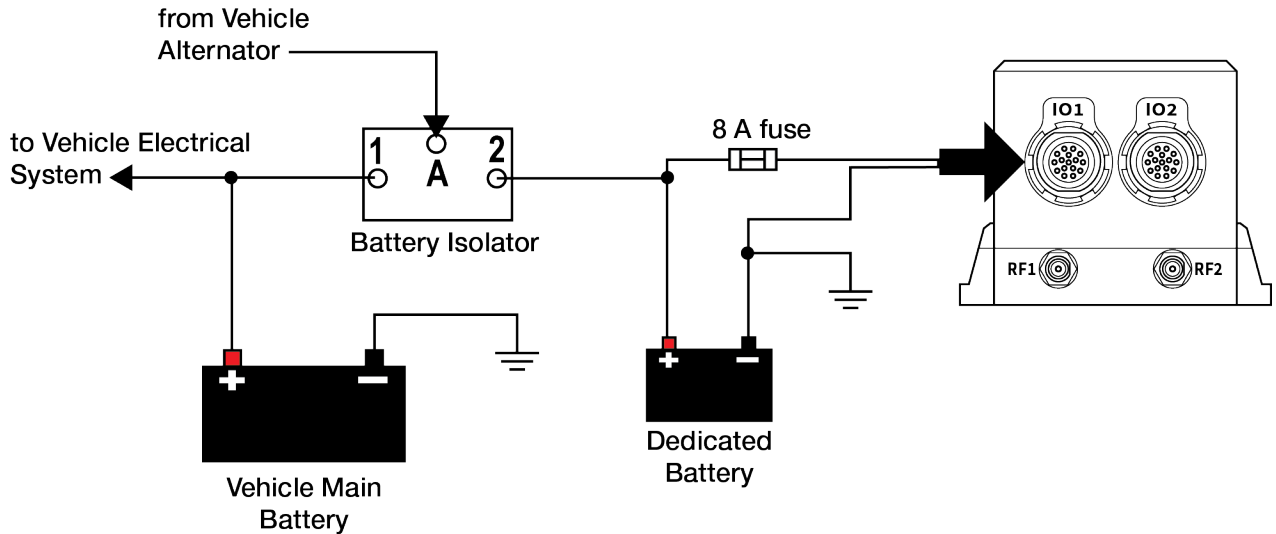

2.14 Check that the SPAN CPT7 is Operating

After the SPAN CPT7 is installed, powered up and connected to a GNSS antenna, use the following procedure to ensure the receiver is operating.

1. Send the following command:

```
LOG VERSION
```

The VERSION log is returned.

```
<VERSION COM1 0 46.0 FINESTEERING 0 5.802 02004020 3681 14755
< 5
< GPSCARD "FDDRYNTBNS1" "DMMU17260099F" "OEM7720-0.00F"
"OM7CR0304AN0002" "OM7BR0002RBG000" "2018/Mar/22" "05:57:24"
< OEM7FPGA "" "" "" "OMV070001RN0000" "" "" ""
< DEFAULT_CONFIG "" "" "" "SC7CR0304AN0002" "" "2018/Mar/22"
"05:57:29"
< PACKAGE "" "" "" "SC7PR0304AN0002" "" "2018/Mar/22" "05:57:48"
< IMUCARD "HG4930_AN01" "" "" "" "" "" ""
```

2. Check that the Time Status is **FINESTEERING** which represents that time is fine set and being steered.
3. Check the Receiver Status word (02004020 in this example). If the lowest bit (bit 0) is set, the receiver has errors.



For information about the other digits in Receiver Status word, refer to the **RXSTATUS** log in the [OEM7 Commands and Logs Reference Manual](#).



It can take about a minute for time status to reach **FINESTEERING** depending on number of satellites being tracked. This assumes the antenna is located in an open sky environment and the RF set up meets the requirements.

Chapter 3 OEM7 Receiver Operation

Before operating the receiver for the first time, use the installation instructions in *SPAN CPT7 Installation* on page 22. The following instructions are based on a configuration similar to the following figure.

Figure 8: Basic SPAN CPT7 Connection Interfaces (example)

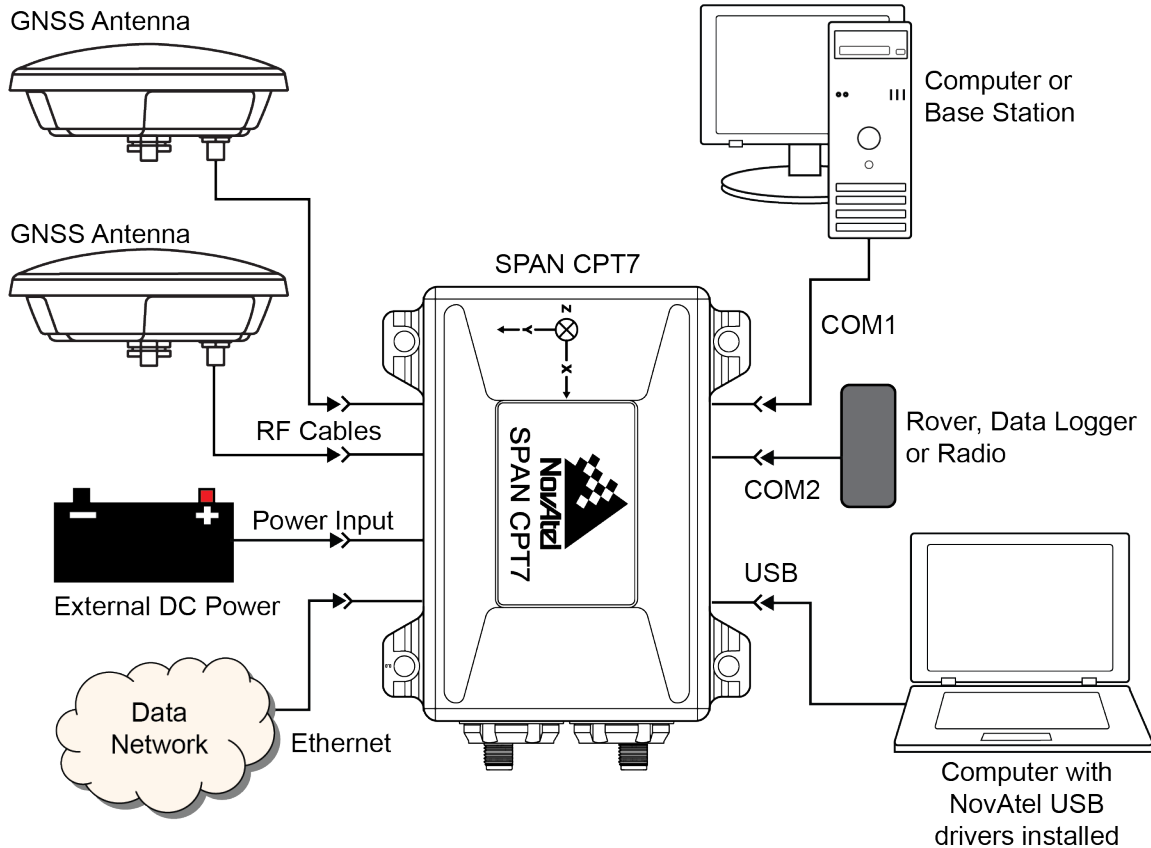

The figure above does not show all necessary hardware. Also see *Figure 9: Basic Differential Setup* on page 41 for a base/rover example.

3.1 Communications with the Receiver

Communication is established with the receiver using a data terminal or computer connected to the receiver by a variety of methods:

- *USB Communications* on the next page
- *Serial Port Communications* on the next page
- *Ethernet Communications* on page 39
- *ICOM Communications* on page 39
- *CAN Bus Communications* on page 39

When connected to the receiver, enter commands directly from a terminal or through terminal emulation software on a computer. For example:

- **NovAtel Web User Interface** - The NovAtel Web User Interface is installed on OEM7 receivers. Refer to the online OEM7 documentation (docs.novatel.com/OEM7) for instructions.
- **NovAtel Connect** - NovAtel Connect is a software application used to monitor and configure NovAtel receivers. For information about installing and using NovAtel Connect, refer to the help file included with the application.



NovAtel Connect version 2.0 or greater is required for OEM7 receivers. Download the latest NovAtel Connect software and documentation from www.novatel.com/novatel-connect.

- Any console/command line application

To maximize the application of the receiver's capabilities, become familiar with the commands and logs described in the [OEM7 Commands and Logs Reference Manual](#).

3.1.1 USB Communications

To communicate between an OEM7 receiver and a computer using a USB port, NovAtel USB drivers must be installed on the computer. These USB drivers are available on the NovAtel website at www.novatel.com/novatel-connect.

USB Drivers

NovAtel USB drivers for OEM7 receivers are available for Windows 7, Window 8, Windows 10 and Linux.

The NovAtel USB drivers provide three virtual serial ports over a single USB 2.0 connection. The three virtual serial ports are available to existing Windows or Linux applications which use COM ports to communicate (for example, NovAtel Connect). The NovAtel USB drivers assign COM port numbers sequentially following any existing ports on the computer. For example, if a computer has COM1 and COM2 ports, the NovAtel USB drivers assign COM3 to USB1, COM4 to USB2 and COM5 to USB3.



USB communications are not suitable for use in vehicles.



A computer has several USB ports. The assignment of COM port numbers is tied to a USB port on the computer. This allows receivers to be switched without Microsoft Windows assigning new COM ports. However, if the receiver is connected to a different physical USB port, Windows detects the receiver's presence and assigns three new COM port numbers.

3.1.2 Serial Port Communications

The receiver can communicate with a computer or terminal via a serial port. For communication to occur, both the receiver and the operator interface have to be configured properly. The receiver's default port settings are:

- 9600 bps
- no parity
- 8 data bits
- 1 stop bit
- no handshaking

- echo off
- break on

The data transfer rate determines how fast information is transmitted. Take for example a log whose message byte count is 96. The default port settings allows 10 bits/byte (8 data bits + 1 stop bit + 1 framing bit). It therefore takes 960 bits per message. To get 10 messages per second then requires 9600 bps. Also remember that even if you set the bps to 9600, the actual data transfer rate may be lower and depends on the number of satellites being tracked, data filters in use, and idle time. It is therefore suggested that you leave yourself a margin when choosing a data rate.



The minimum suggested baud rate for most applications is 115200 bps for GNSS only or 230400 bps for GNSS+INS. If the buffer overrun flag is present in the **RXSTATUS** log (refer to the [OEM7 Commands and Logs Reference Manual](#)), log at a higher baud rate if possible, or change to a medium supporting higher bandwidth (USB or Ethernet).



Although the receiver can operate at data transfer rates as low as 300 bps, this is not recommended. For example, if several data logs are active (that is, a significant amount of information needs to be transmitted every second) but the bit rate is set too low, data overflows the serial port buffers, causing an error condition in the receiver status that results in lost data.

The following ports are supported and can be configured using the commands listed. Refer to the commands listed in the [OEM7 Commands and Logs Reference Manual](#) for detailed instructions.

Table 4: Serial Ports Supported

Receiver Type	Port Supported	Configuration Command
SPAN CPT7	COM1, COM2	SERIALCONFIG

Change the COM Port Settings

To change the settings on a COM port, use the **SERIALCONFIG** command. For example:

- To change the data rate of COM2 to 115200, enter:

```
SERIALCONFIG COM2 115200
```

- To change the data rate of COM1 to 57600 and enable even parity, enter:

```
SERIALCONFIG COM1 57600 E
```

Communicating using a Remote Terminal

One method of communicating with the receiver is through a remote terminal. To communicate with the terminal, the receiver requires only the RX, TX and GND lines be used. Ensure the terminal's communications set up matches the receiver's port settings.

Communicating using a Computer

A computer can emulate a remote terminal as well as provide the added flexibility of supporting multiple command batch files and data logging storage files. Use any standard communications software package that emulates a terminal to establish bidirectional communications with the receiver. Examples include NovAtel Connect and PuTTY. All data is sent as raw 8-bit binary or ASCII characters.

Refer to *Communicating with the Receiver* on page 40 for details.

3.1.3 Ethernet Communications

The SPAN CPT7 is equipped with a 10-Base-T/100-Base-TX Ethernet port that supports IPv4 Internet layer, TCP/IP transport and telnet. Users can conduct remote debugging, accept MRTCA (modified RTCA) data and update firmware. OEM7 receivers are also equipped with NTRIP Version 2.0 (Networked Transport of RTCM via Internet Protocol) client and server capability.

The Ethernet port must be configured before using. Refer to *Ethernet Configuration* on page 99 for configuration details.



The Ethernet ports are Safety Extra-Low Voltage (SELV) circuits only and are suitable for connection within a building only. Do not connect them to Telephone Network Voltage (TNV) circuits.

If intra-building connections are required, or the OEM7 receiver is installed in an outdoor enclosure, a suitably rated Ethernet router or switch should be installed between the receiver Ethernet port and the network connection.



Issue the **SAVEETHERNETDATA ETHA** command to ensure port settings are retained after a reset and automatically used at boot time. The **SAVEETHERNETDATA ETHA** command is not applicable to the **ICOMCONFIG** and **NTRIPCONFIG** command settings. The **SAVEETHERNETDATA ETHA** command takes precedence over the **SAVECONFIG** command configuration.

3.1.4 ICOM Communications

ICOM ports are virtual ports used for Ethernet connections. The transport/application layer of the ICOM ports can be configured to use Transmission Control Protocol (TCP) for internet IP or User Datagram Protocol (UDP) a slower and less reliable IP protocol.

Refer to **DNSCONFIG** command for Ethernet DNS configuration. If using DHCP, DNS is automatically set.

The following are the default ICOM configurations:

- ICOMCONFIG ICOM1 TCP :3001
- ICOMCONFIG ICOM2 TCP :3002
- ICOMCONFIG ICOM3 TCP :3003
- ICOMCONFIG ICOM4 TCP :3004
- ICOMCONFIG ICOM5 TCP :3005
- ICOMCONFIG ICOM6 TCP :3006
- ICOMCONFIG ICOM7 TCP :3007

Each ICOM port can act as a server (waiting for an external connection to be made) or as a client (actively establishing a connection to a specific port).

For details on the ICOM port commands, refer to **IPCONFIG** command, **ICOMCONFIG** command and **ETHCONFIG** command in the [OEM7 Commands and Logs Reference Manual](#).

3.1.5 CAN Bus Communications

The OEM7 receiver supports J1939 and NMEA2000 CAN protocols.

The SPAN CPT7 has one CAN port. This CAN port supports data rates up to 1 Mbps.

Proper bus termination is required.

Refer to *CAN Bus* on page 108 for detailed instructions.

3.2 Getting Started

The receiver's software resides in flash memory. When first powered, it undergoes a complete self-test. If an error condition is detected during the self-test, the status word changes. This self-test status word can be viewed in the header of any data output log. Refer to Messages in the [OEM7 Commands and Logs Reference Manual](#) for header information. If a persistent error occurs, contact your local NovAtel dealer. If the dealer cannot resolve the problem, contact NovAtel Customer Support directly using one of the methods listed in *Customer Support* on page 17.

3.2.1 Communicating with the Receiver

You can communicate with the receiver using NovAtel Web User Interface, NovAtel Connect or a terminal emulation program.



Detailed instructions for using NovAtel Connect are available from the Help system built into NovAtel Connect.



For instructions on using NovAtel Web User Interface, refer to the online OEM7 documentation (docs.novatel.com/OEM7).

When the receiver is first turned on, no data is transmitted from the COM ports except for the port prompt.

Any of the COM port prompts indicate that the receiver is ready and waiting for command input. The screen may display other port names for other port types.



1. Output from receiver self-tests may take some time. On startup, the receiver is set to log the RXSTATUSEVENTA log ONNEW on all ports. See *RXSTATUSEVENT Log* on page 114 for more details.
2. If NovAtel Connect is unable to locate the receiver, use a different COM port to communicate with the receiver. When communication has been established, issue a **FRESET STANDARD** command. The original communications port should be ready for use. See the **FRESET** command for more information.

An example of a response to an input **LOG** command:

```
[COM2] LOG COM1 BESTPOS ONTIME 1
<OK
```

In this example, [COM2] is the port prompt.

If the command was accepted, the receiver responds with:

```
<OK
```

If a command is entered incorrectly, the receiver responds with:

```
<ERROR:Invalid Message ID (or a more detailed message)
```



Ensure the computer does not sleep or hibernate during a logging session or data will be lost.

3.3 Transmitting and Receiving Corrections

Corrections can be transmitted from a base station to a rover station to improve position accuracy. The base station is the GNSS receiver that acts as the stationary reference. The stationary reference has a known position and transmits correction messages to the rover station. The rover station is the GNSS receiver that does not know its exact position and requires correction messages from a base station to calculate differential GNSS positions. An example of a differential setup is shown in *Figure 9: Basic Differential Setup* below.

Figure 9: Basic Differential Setup

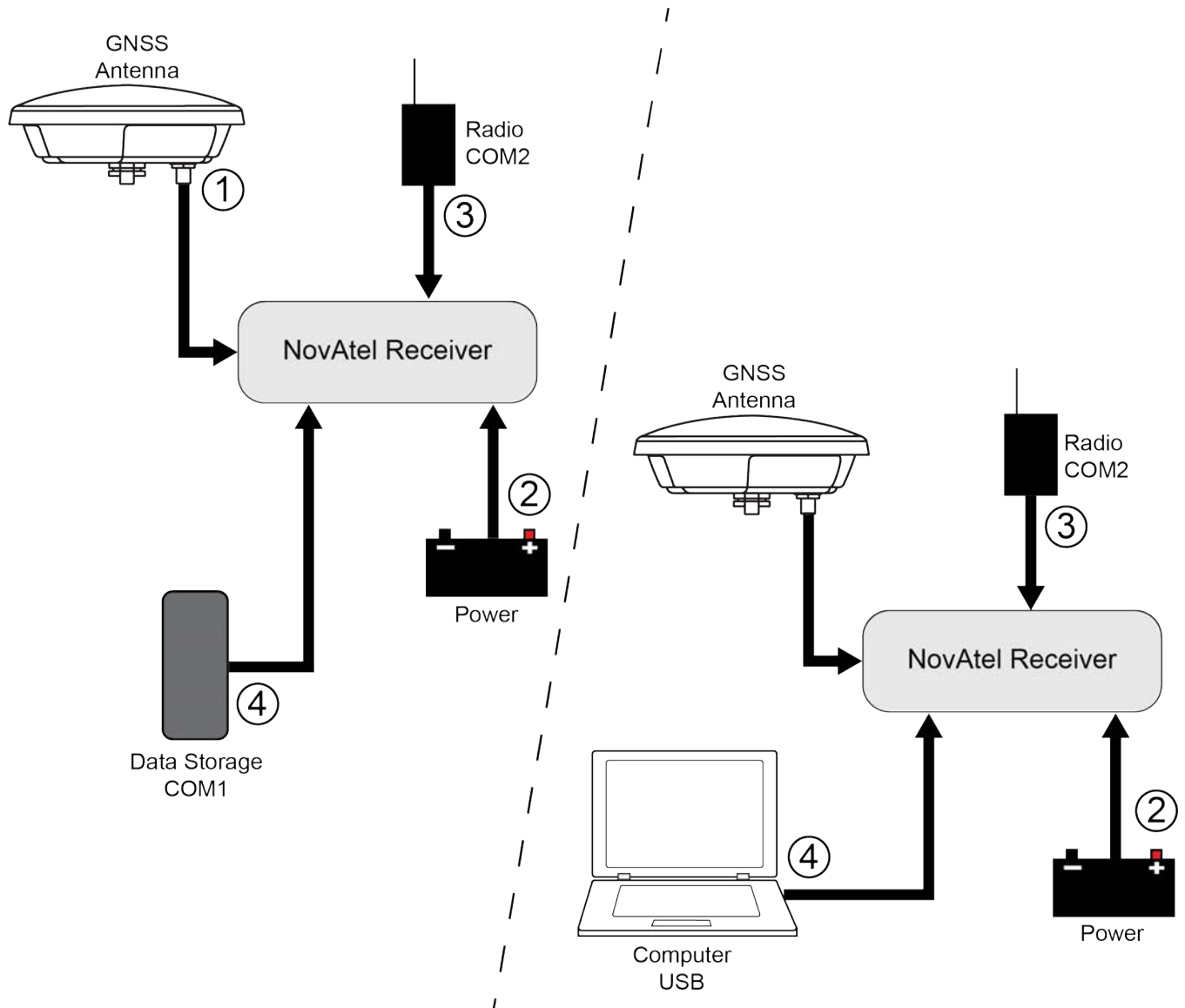

Rover Setup

- 1 Mount and connect a GNSS antenna
- 2 Connect a fused power supply (user supplied)
- 3 Connect a radio device to COM2 (user supplied)
- 4 Connect a storage device to COM1 (user supplied)

Base Setup

- 1 Mount and connect a GNSS antenna
- 2 Connect a fused power supply (user supplied)
- 3 Connect a radio device to COM2 (user supplied)
- 4 Connect a computer to COM1 for setup and monitoring (user supplied)

To receive corrections, a data link between the base station and the rover station is required. The base and rover stations can both be NovAtel receivers, however NovAtel receivers will work with some other brands. Contact Customer Support for further details (refer to *Customer Support* on page 17 for details).

The data link should support a rate of at least 19200 bits per second, but a rate of 115200 bits per second, with less than 4.0 s latency, is recommended.



Unlike the base/rover concept, SBAS and PPP corrections can be applied directly to a single receiver.

When the base and rover are set up, configure them as shown in the configuration examples in *Base Station Configuration* below and *Rover Station Configuration* on the next page.

3.3.1 Defining Antenna and Base Antenna

The type of antenna for the receiver and/or the base receiver can be defined using the **THISANTENNATYPE** command and **BASEANTENNATYPE** command respectively.

The Phase Center Variation (PCV) and the Phase Center Offset (PCO) for each can also be specified using the **THISANTENNAPCV** command and **THISANTENNAPCO** command or the **BASEANTENNAPCV** command and **BASEANTENNAPCO** command.

Refer to the [OEM7 Commands and Logs Reference Manual](#) for command details.

3.3.2 Base Station Configuration

At the base station, enter the following commands:

```
serialconfig [port] baud [parity[databits[stopbits[handshaking[break]]]]]
interfacemode port rx_type tx_type [responses]
fix position latitude longitude height (enter your own lat, long and hgt values)
log port message [trigger [period]] (port = COM2 / refer to Figure 9: Basic Differential Setup
on the previous page)
saveconfig (optional)
```

The following sections are examples of base station configurations.

RTK Automated Correction Generation

```
fix position lat lon hgt (enter your own lat, lon, hgt)
generatertkcorrections rtkmv3 com2
```

RTCM V3

```
serialconfig com2 19200 N 8 1 N on
interfacemode com2 none rtkmv3 off
fix position lat lon hgt (enter your own lat, lon, hgt)
log com2 rtkm1004 ontime 1
log com2 rtkm1006 ontime 10
log com2 rtkm1019 ontime 120
saveconfig (optional)
```

RTCM V3 with GLONASS

```

serialconfig com2 19200 N 8 1 N on
interfacemode com2 none rtcmv3 off
fix position lat lon hgt (enter your own lat, lon, hgt)
log com2 rtcml004 ontime 1
log com2 rtcml012 ontime 1
log com2 rtcml006 ontime 10
log com2 rtcml033 ontime 10
log com2 rtcml019 ontime 120
log com2 rtcml020 ontime 120
saveconfig (optional)

```

NOVATELX

```

serialconfig com2 19200 N 8 1 N on
interfacemode com2 none novatelx off
fix position lat lon hgt (enter your own lat, lon, hgt)
log com2 novatelxobs ontime 1
saveconfig (optional)

```



For more information, refer to the **FIX** command, **INTERFACEMODE** command, **SAVECONFIG** command and **SERIALCONFIG** command in the [OEM7 Commands and Logs Reference Manual](#).

3.3.3 Rover Station Configuration

At the rover station, enter the following commands:

```

serialconfig [port] baud [parity[databits[stopbits[handshaking[break]]]]]
interfacemode port rx_type tx_type [responses]
saveconfig (optional)

```

The following sections are examples of rover configurations, if COM2 was connected to the correction source.

RTK Automated Correction Detection

```

serialconfig com2 19200 N 8 1 N on
interfacemode com2 auto none off
saveconfig (optional)

```

RTCM V3

```

serialconfig com2 19200 N 8 1 N on
interfacemode com2 rtcmv3 none off
saveconfig (optional)

```

RTCM V3 with GLONASS

```
serialconfig com2 19200 N 8 1 N on
interfacemode com2 rtcmv3 none off
saveconfig (optional)
```

NOVATELX

```
serialconfig com2 19200 N 8 1 N on
interfacemode com2 NOVATELX none off
saveconfig (optional)
```



For more information, refer to the **INTERFACEMODE** command, **SAVECONFIG** command and **SERIALCONFIG** command in the [OEM7 Commands and Logs Reference Manual](#).

3.3.4 Configuration Notes

For compatibility with other GNSS receivers and to minimize message size, use the standard form of RTCMV3 corrections shown in the base and rover examples in *Transmitting and Receiving Corrections* on page 41. This requires using the **INTERFACEMODE** command to dedicate one direction of a serial port to one message type only. When the **INTERFACEMODE** command is used to change the mode from the NOVATEL default, the NovAtel format messages can no longer be used.

To mix NovAtel format messages and RTCM V3 messages on the same port, leave the interface mode set to NOVATEL and log out variants of the standard correction messages with a NovAtel header. ASCII or binary variants can be requested by appending an A or B to the standard message name. For example, on the base station:

```
interfacemode com2 novatel novatel
fix position 51.11358042 -114.04358013 1059.4105
log com2 rtcml004b ontime 2
```



1. Interface mode must be set to NOVATEL for the receiver to issue logs with an A or B suffix.
2. Using the receiver in NOVATEL mode consumes more CPU bandwidth than using the native differential messages as shown in *Base Station Configuration* on page 42.
3. To find information on how to send multiple commands and log requests from a computer, search our knowledge database available at www.novatel.com/support/.

At the rover, leave the interface mode default settings (interfacemode com2 novatel novatel). The rover recognizes the default and uses the corrections it receives with a NovAtel header.

The **PSRDIFFSOURCE** command and **RTKSOURCE** command set the station ID values that identify the base stations from which to accept pseudorange or RTK corrections. They are useful commands when the rover station is receiving corrections from multiple base stations.

3.4 GLIDE

NovAtel's GLIDE[®] is a positioning algorithm for single-frequency GPS and GPS/GLONASS applications. GLIDE produces a smooth position output tuned for applications where time relative accuracy (pass-to-pass) is more important than absolute accuracy. Because of this, it is well suited for agricultural applications.

Multipath signals tend to induce time varying biases and increase the measurement noise on the L1/L2 pseudorange measurements. Carrier phase measurements are much less susceptible to the effects of multipath. The GLIDE algorithm fuses the information from the L1 code and the L1 phase measurements into a Position Velocity Time (PVT) solution.

GLIDE includes settings for a dynamic mode, a static mode and an “auto” mode, where the filtering parameters are automatically adjusted as vehicle velocity varies between stationary and dynamic states.

3.4.1 Dual-Frequency GLIDE

NovAtel’s dual-frequency GLIDE technology adds to the superior pass-to-pass performance provided by single-frequency GLIDE. Dual-frequency GLIDE is ideal for agricultural and machine guidance applications where relative positioning is critical. Using GLIDE significantly reduces the variation in position errors to less than 1 cm from one epoch to the next. Dual-frequency GLIDE improves the absolute accuracy of the GLIDE position and creates a robust solution resistant to the effects of high ionospheric activity. GLIDE works in all code positioning modes, including single point, DGNSS and SBAS.

Refer to the NovAtel white paper on [GLIDE Technology](#) for more information on GLIDE and [APN-038 Pseudorange/Delta-Phase \(PDP\) and GLIDE Filters](#) along with other information available from www.novatel.com/support/search/.

3.4.2 PDP and GLIDE Configurations

Pseudorange/Delta-Phase (PDP) and GLIDE position filters can be used for single-frequency single point, WAAS or DGNSS positioning. Refer to the **PDPFILTER** command and **PDPMODE** command in the [OEM7 Commands and Logs Reference Manual](#).

To reset the PDP or GLIDE filter:

```
pdpfilter reset
```

To enable the PDP filter:

```
pdpfilter enable
```

Ensure the **PDPFILTER** command is used before the **PDPMODE** command. Set the PDP type and kinematic type according to the application. For most kinematic applications:

```
pdpmode relative dynamic or pdpmode relative auto
```

The rest of the setup is position type and log dependent according to the application. See the **PSRDIFFSOURCE**, **INTERFACEMODE**, **SERIALCONFIG** and other configuration commands which are outlined in the [OEM7 Commands and Logs Reference Manual](#). Also refer to the NovAtel application note [APN-038 Pseudorange/Delta-Phase \(PDP\) and GLIDE](#) available from our web site at www.novatel.com/support/.

3.5 STEADYLINE

The STEADYLINE® functionality helps mitigate the discontinuities that often occur when the receiver changes GNSS positioning modes. The effect is especially evident when a receiver transitions from an RTK position mode solution to a lower accuracy “fall back” solution, such as DGPS, WAAS+GLIDE or even autonomous GLIDE (see *Figure 10: Positioning Change Without STEADYLINE* on the next page). Smooth transitions are particularly important for agricultural steering applications where sudden jumps are problematic.

Figure 10: Positioning Change Without STEADYLINE

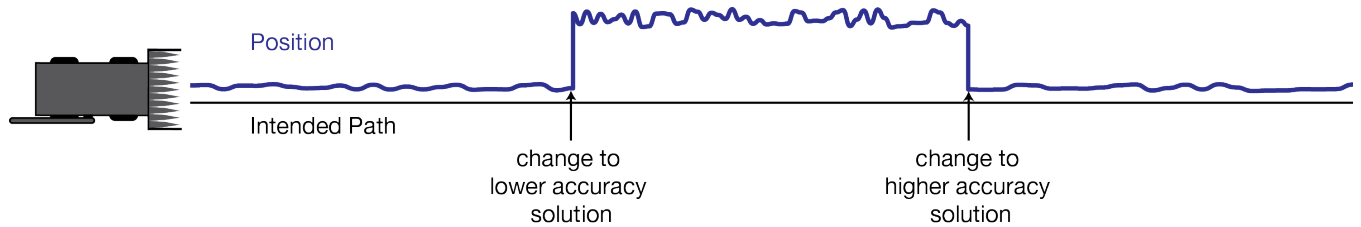

The STEADYLINE feature internally monitors the position offsets between all the GNSS positioning modes present in the receiver. When the current positioning mode becomes unavailable, the receiver transitions to the next most accurate positioning mode.



Refer to the [OEM7 Commands and Logs Reference Manual](#) for log and command details.

3.5.1 Prefer Accuracy

The positioning mode change depends on the accuracy level of the positioning modes.

When the position mode is changing from a more accurate mode to a less accurate mode (e.g., changing from RTK to GLIDE), the receiver uses the position offset calculated to limit a potential real position jump.

When the position mode is changing from a less accurate mode to a more accurate mode (e.g., GLIDE to RTK), the receiver slowly transitions to the new reference position type over the time period specified by the Transition time parameter.

For example, a receiver is configured to do both RTK and GLIDE. If this receiver has a fixed RTK position and experiences a loss of correction data causing the loss of the RTK solution it will immediately apply the offset between the two position modes and uses the GLIDE position stability to maintain the previous trajectory. Over time the GLIDE (or non-RTK) position will experience some drift. Once the RTK position is achieved again the receiver will start using the RTK positions for position stability and will slowly transition back to the RTK positions at a default rate of 0.005 m/s or the time specified in the **STEADYLINE** command.

Figure 11: STEADYLINE Prefer Accuracy

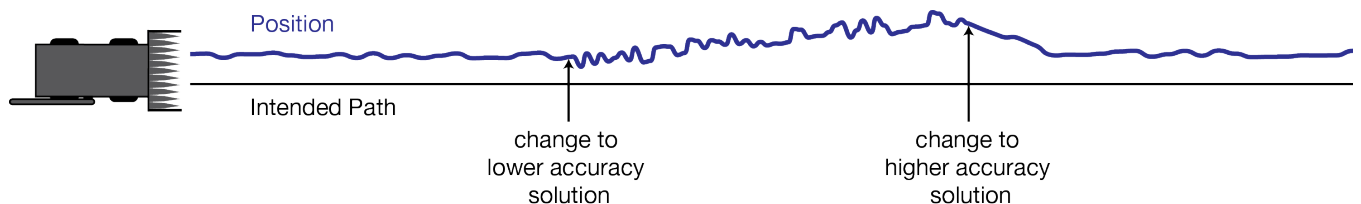

3.6 Enabling SBAS Positioning

OEM7 receivers are capable of SBAS positioning. This positioning mode is enabled using the **SBASCONTROL** command:

```
sbascontrol enable auto
```

When the command is entered, the OEM7 receiver automatically tracks the SBAS that is operating in the region (e.g., WAAS or EGNOS) and applies the corrections from the service. On a simulator, leave the test mode parameter off or specify NONE explicitly. For more on SBAS, refer to application note [APN-051 Positioning Modes of Operation](#) (additional Application Notes available at www.novatel.com/support/).

3.7 Enabling PPP

L-Band equipped receivers can achieve sub-meter position accuracy using correction data received from geostationary satellites. To use the L-Band corrections, an L-Band-capable receiver model and antenna are required (refer to our web site www.novatel.com/products/gnss-antennas for information on NovAtel L-Band-capable antennas).

For more information on L-Band positioning, refer to:

- NovAtel Application Notes: *APN-061: NovAtel CORRECT with PPP using TerraStar Corrections* or *APN-062 NovAtel CORRECT with Veripos* (service dependent) available from www.novatel.com/support/search/items/Application%20Note
- the [OEM7 Commands and Logs Reference Manual](#) for log/command details and/or
- visit www.novatel.com/support
- visit www.novatel.com/products/novatel-correct

3.7.1 TerraStar Subscriptions

A subscription is required to use TerraStar service for land, airborne and near shore applications. Near shore applications are defined as vessels operating within 10 km of shore. For more information about TerraStar services, visit www.novatel.com/products/terrestar-gnss-corrections. To obtain a subscription, contact your local NovAtel sales representative. The NovAtel product serial number (PSN) is needed to obtain a subscription. To obtain the receiver serial number, enter the following command:

```
log version once
<VERSION USB1 0 74.0 FINESTEERING 2045 336197.080 02028020 3681 15341
< 11
< GPSCARD "FFNRNNCBES1" "BMHR17090005E" "OEM7700-1.00" "OM7CR0504RN0000"
"OM7BR0001RBG000" "2019/Jan/17" "07:30:03"
< OEM7FPGA "" "" "" "OMV070001RN0000" "" "" ""
< WHEELSENSOR "" "" "" "SWS000101RN0000" "" "2019/Jan/17" "07:30:30"
< WIFI "RS9113" "" "" "1.6.8" "" "2019/Jan/17" "07:30:35"
< APPLICATION "" "" "" "EP7AR0504RN0000" "" "2019/Jan/17" "07:30:16"
< DEFAULT_CONFIG "" "" "" "EP7CR0504RN0000" "" "2019/Jan/17" "07:30:26"
< PACKAGE "" "" "" "EP7PR0504RN0000" "" "2019/Jan/17" "07:30:21"
< DB_WWWISO "WWWISO" "0" "" "WMC010201AN0004" "" "2017/Sep/20" "21:00:04"
< ENCLOSURE "" "NMNE17200009B" "" "" "" "" ""
< REGULATORY "US" "" "" "" "" "" ""
< IMUCARD "Epson G320N" "" "" "" "" "" ""
```

In the example above, the receiver serial number is **BMHR17090005E**.

To activate a subscription, the receiver must be powered and tracking an L-Band TerraStar satellite prior to the planned activation time. Use the **ASSIGNLBANDBEAM** command to configure the receiver to track the TerraStar satellite.

```
ASSIGNLBANDBEAM auto
```

To confirm tracking of an L-Band signal, log the L-Band tracking status information by entering the following command:

```
log lbandtrackstata
#LBANDTRACKSTATA,COM1,0,73.5,FINESTEERING,1769,328196.000,00000000,29fd,
12602;1,"98W",1539902500,1200,974c,00c2,0,-316.186,43.842,4.3840,61.920,
1088,2,2,138176,79,0.0001*3e43cb7d
```

If receiving an L-Band signal from a geostationary satellite, the sixth field following the header (tracking status word) of the LBANDTRACKSTAT log will be 00c2, as shown in the example.



The latest services and coverage can be obtained from www.novatel.com/products/novatel-correct-ppp/. For additional information on TerraStar activation, contact NovAtel Customer Service at www.novatel.com/support or download *APN-061 NovAtel CORRECT with TerraStar* from: www.novatel.com/support/search/items/Application%20Note

To confirm the TerraStar subscription status, send the **TERRASTARSTATUS** log:

```
log terrastarstatus

[COM1]<TERRASTARSTATUS COM1 0 74.0 FINESTEERING 1886 418216.025 00000020 fdc1
13386 ENABLE LOCKED 0 IN_RANGE DISABLED
[COM1]
```

The first field after the log header will be **ENABLE** to indicate the TerraStar subscription is valid. The second field after the log header will be **LOCKED** to indicate the decoder is locked to the data format.

To monitor the PPP convergence, request the **PPPPOS** log:

```
log ppppos ontime 1

[COM1]<PPPPOS COM1 0 76.0 FINESTEERING 1886 418465.000 00000020 ec34 13386 SOL_
COMPUTED PPP_CONVERGING 51.11679035745 -114.03886212905 1064.9475 -16.9000
WGS84 0.7097 0.6867 1.2333 "TSTR" 25.000 0.000 18 17 17 17 00 00 00 33
[COM1]
```

Automatic Multi-Constellation, Multi-Frequency

When using TerraStar service, a multi-constellation, multi-frequency channel configuration gives better accuracy and faster convergence time compared to a dual-constellation, dual-frequency channel configuration. To allow the receiver to make best use of the TerraStar subscription, a multi-constellation, multi-frequency configuration is automatically activated included with TerraStar-X, TerraStar-C PRO or RTK ASSIST PRO subscriptions.

To enable multi-constellation, multi-frequency channel configurations while a TerraStar-X, TerraStar-C PRO or RTK ASSIST PRO subscription is active, a receiver reset is required.

```
TERRASTARCHANCONFIG ENABLE
SAVECONFIG command
```

For more information, or to disable Multi-Constellation, Multi-Frequency channel configuration, see the **TERRASTARAUTOCHANCONFIG** command.



If the TerraStar-X, TerraStar-C PRO or RTK ASSIST PRO subscription becomes inactive, the receiver will revert to the channel configuration enabled by the receiver model.



This feature is available on OEM firmware version 7.06.01 and later.

3.7.2 Veripos Subscriptions



Subscriptions to the Veripos Apex and Apex² marine services must be obtained directly from Veripos. A unit with a marine subscription can not be switched to a land subscription and vice versa.

A subscription is required to use the [Veripos services](#) for offshore marine applications. Contact Veripos sales at veripos.com/support to obtain a Service Access License (SAL) number. To activate the service, contact the Veripos Help Desk at +44 (0) 1224 527 104 or visit veripos.com/support. Provide the SAL number and the receiver's Veripos Serial Number (VSN). To obtain the receiver-specific VSN, enter the following command:

```
log veriposinfo
```

The log displays the VSN in the first field following the log header and also displays the status of your subscription.

To activate a subscription, the receiver must be powered and tracking an L-Band Veripos satellite prior to the planned activation time. Use the **ASSIGNLBANDBEAM** command to configure the receiver to track the Veripos satellite.

```
assignlbandbeam auto
```



The latest services and coverage can be obtained from www.veripos.com. For additional information on Veripos activation, contact NovAtel Customer Service at www.novatel.com/support or download the APN-062 NovAtel CORRECT with Veripos from: www.novatel.com/support/search/items/Application%20Note

3.8 RTK ASSIST

RTK ASSIST™ is a feature that enables centimeter-level accuracies to be maintained through extended RTK correction outages. With RTK ASSIST, RTK-dependent operations can continue through RTK correction outages as long as 20 minutes.

RTK ASSIST uses correction data provided by TerraStar. To obtain these corrections, an L-Band capable receiver is required and L-Band tracking must be enabled using the **ASSIGNLBANDBEAM** command.

RTK ASSIST also requires a subscription to the RTK ASSIST service. To obtain a subscription, contact your local NovAtel sales representative or visit www.novatel.com/products/terrastar-gnss-corrections/. The NovAtel Product Serial Number (PSN) is needed to obtain a subscription. The PSN is available from the **VERSION** log.

RTK ASSIST is available as soon as the rover receiver has at least one valid RTK solution and has received the RTK ASSIST correction data. If an RTK correction outage occurs, then RTK ASSIST will maintain RTK mode until the subscription-permitted RTK ASSIST duration is exceeded. A shorter, user-defined RTK ASSIST time out can also be set using the **RTKASSISTTIMEOUT** command. Normal RTK operation will seamlessly resume if RTK corrections are restored at any point while RTK ASSIST is operating.

RTK ASSIST will report the RTK solution type that was present before RTK corrections were lost, unless the estimated solution standard deviation exceeds the threshold set by the **RTKINTEGCRITERIA** command. If this occurs, then integer RTK solutions will be downgraded to their float RTK equivalent.

RTK ASSIST is enabled by default, but can be disabled using the **RTKASSIST** command. To monitor the status of RTK ASSIST, view the **RTKASSISTSTATUS** log.

Refer to the [OEM7 Commands and Logs Reference Manual](#) for log and command details.



RTK ASSIST typically provides 4 cm accuracy. However, if the RTK outage occurs during the first 30 minutes of receiver operation, the position accuracy provided by RTK ASSIST may be lower.



Additional information about enabling and using RTK ASSIST is available in the RTK ASSIST Application Note (available from our website: www.novatel.com/assets/Documents/Bulletins/APN-073-RTK-ASSIST.pdf).

3.9 Transferring Time Between Receivers

The **ADJUST1PPS** command is used as part of the procedure to transfer time between receivers. The number of Pulses Per Second (PPS) is always set to 1 with this command. It is typically used when the receiver is not adjusting its own clock and is using an external reference frequency.

The **TIMESYNC** log is also used to synchronize time between receivers. It contains a time status field that may show COARSE or FINE, among others. For a complete list of the time status values and definitions, refer to GPS Reference Time Status in the [OEM7 Commands and Logs Reference Manual](#).

Procedures to Transfer Time on the next page provides details on the time transfer procedure. Terms used in the procedure are defined in *Time Definitions* below. Refer also to the **ADJUST1PPS** command and the **TIMESYNC** log in the [OEM7 Commands and Logs Reference Manual](#).

3.9.1 GPS to Receiver Time Synchronization

Receiver time synchronization with GPS time does not occur until the receiver locks onto the first satellite. The GPS L1 signal has two main streams of data modulated on the carrier. These data streams are the C/A code (1.023 MHz rate) and the P(Y) code (10.23 MHz rate). Additionally, a navigation message (at a 50 Hz rate) contains GPS satellite data including the ephemeris, clock corrections and constellation status. This navigation message is encoded on both the C/A and P(Y) codes. The navigation message is transmitted via individual subframes and each subframe is 300 bits in length. With the 50 Hz data bit rate there is a new subframe transmitted every six seconds.

3.9.2 Time Definitions

The following are related definitions:

Coarse Time

Each subframe contains the transmit time of the next subframe in seconds of GPS Time of Week (TOW). After the first subframe is collected and decoded by the receiver, an approximate calculation of the receiver clock offset can be made. The receiver clock offset is the difference between GPS time and internal receiver time. The calculation is based on subframe transmit time and the approximate propagation time from the satellite signal to the receiver. The position of the satellite and receiver clock offset are used to re-initialize the seconds counter on the receiver, resulting in receiver/GPS time synchronization. The accuracy of the receiver time is expected to be within 30 milliseconds (ms) of GPS time. This initial synchronization is referred to as coarse time and is indicated by COARSE in the time status field of the **TIMESYNC** log.

Fine Time

When at least four satellites are acquired to calculate the antenna position, a more accurate estimate of the receiver clock offset is calculated. The new receiver clock offset is used to synchronize the receiver clock even closer to GPS time. This is referred to as fine time and appears as FINE or FINESTEERING in the time status field of the **TIMESYNC** log. Fine time accuracy is a function of the GPS constellation status and is influenced by external receiver RF delay. For the Standard Position Service (SPS) the time accuracy is specified as 20 ns (1 sigma) with internal compensation.

Fine Clock

An OEM7 receiver that is tracking satellites and has a FINE or FINESTEERING receiver clock state.

Cold Clock

An OEM7 receiver that needs to have its clock synchronized with the Fine receiver. It may have any clock state (except FINE or FINESTEERING) that includes UNKNOWN.

Warm Clock

An OEM7 receiver that has its clock adjusted to greater than 500 ms. Refer to the **TIME** log to view the clock offset.



The [OEM7 Commands and Logs Reference Manual](#) contains details of the logs mentioned above.

3.9.3 Procedures to Transfer Time

These procedures are used to transfer time between a fine clock and a cold or warm clock GPS receiver.



When connecting two receivers to transfer time, disable responses on the COM port used to connect the receivers by issuing the following command on both receivers:

```
interfacemode comX novatel novatel none
```

Where comX is the port used on the receiver.

Transfer COARSE Time (<10 ms) from a Fine Clock to a Cold Clock GPS Receiver

1. Connect a COM, USB or Ethernet port from the fine clock receiver to the cold clock receiver (for example, COM2 on the fine clock receiver to COM3 on the cold clock receiver) as shown in *Figure 12: Transfer COARSE Time from Fine Clock to Cold Clock Receiver* on the next page. Configure both ports to the same baud rate and handshaking configurations.
2. Issue the following command to the fine clock receiver:

```
log com2 timesyncb ontime 1
```

3. Issue the following command to the cold clock receiver:

```
adjust1pps time
```

When the cold clock receiver receives the **TIMESYNC** log, it sets its clock with a 100 ms transfer delay allowance.

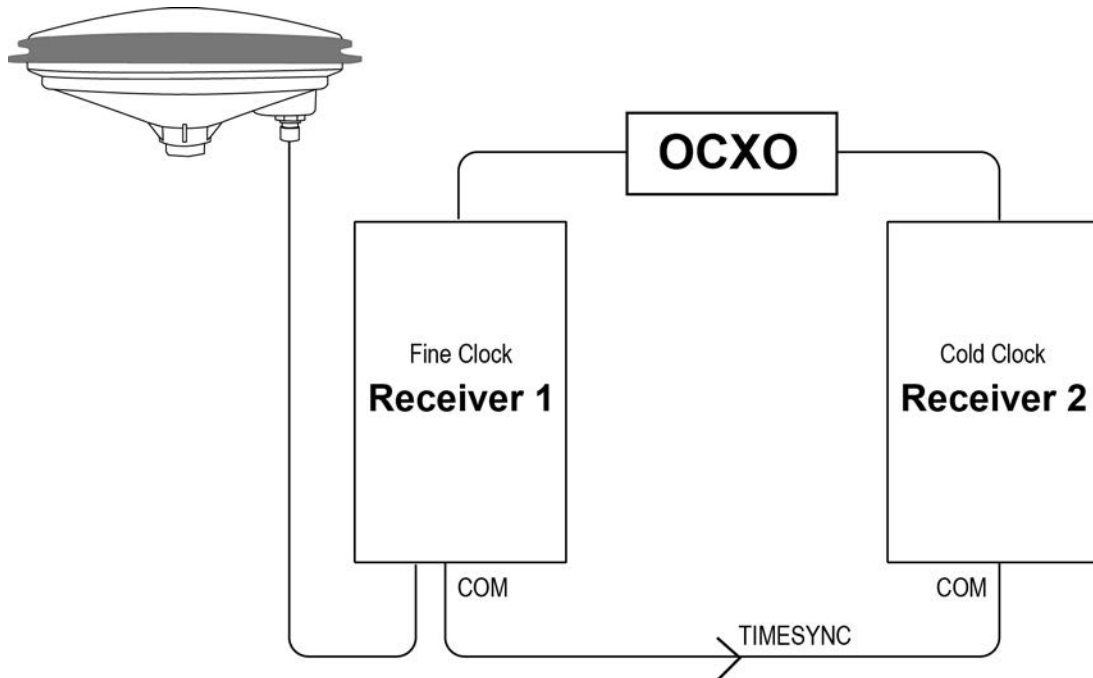
Figure 12: Transfer COARSE Time from Fine Clock to Cold Clock Receiver**Transfer FINE Time (<50 ns) from a Fine Clock to a Cold Clock GPS Receiver**

1. Connect a COM, USB or Ethernet port from the fine clock receiver to the cold clock receiver (for example, COM2 on the fine clock receiver to COM3 on the cold clock receiver), as shown in *Figure 13: Transfer FINE Time from Fine Clock to Cold Clock Receiver* on the next page. Configure both ports to the same baud rate and handshaking configurations.
2. Issue the following command to the fine clock receiver:

```
log com2 timesyncb ontime 1
```

3. Connect the 1PPS signal of the fine clock receiver to the Mark 1 input (Event1) of the cold clock receiver.
4. Issue the following command to the cold clock receiver:

```
adjust1pps markwithtime
```

When the cold clock receiver receives the 1PPS event from the fine clock receiver, it checks to see if a valid **TIMESYNC** log has arrived within 200 ms of the last 1PPS event. If so, it sets the cold clock receiver clock to the time of the fine clock receiver. See *Figure 15: 1 PPS Alignment* on page 54.

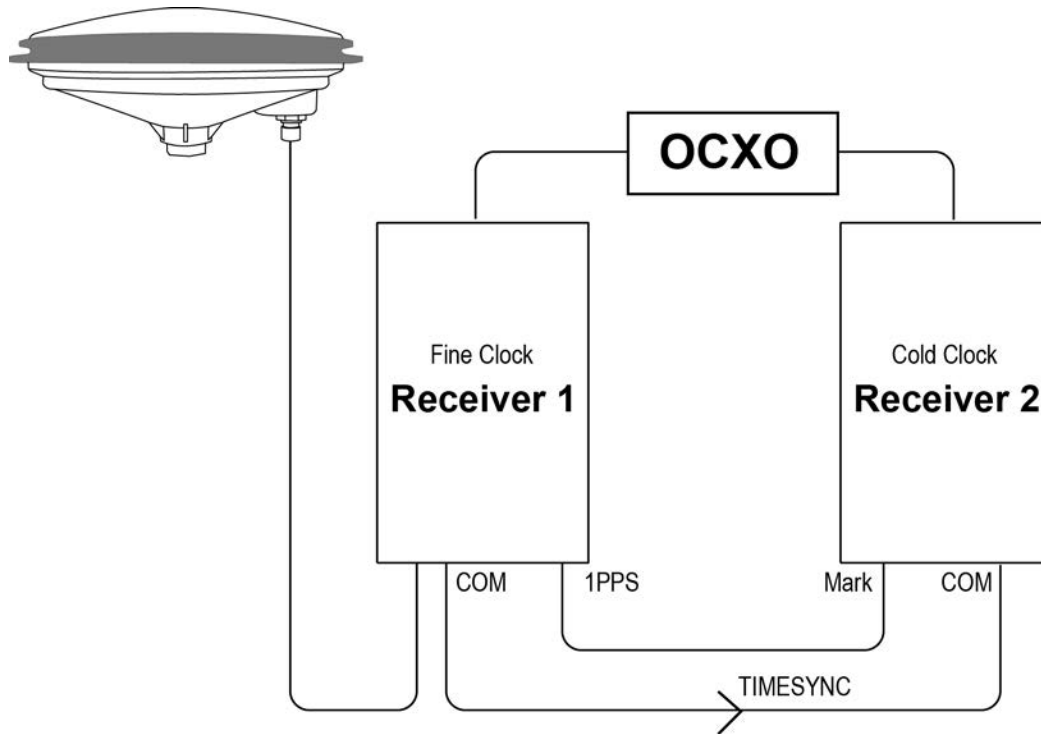
Figure 13: Transfer FINE Time from Fine Clock to Cold Clock Receiver

Transfer FINE Time from a Fine Clock to a Warm Clock GPS Receiver

1. Connect the 1 PPS signal of the fine clock receiver to the Mark 1 input (Event1) of the warm clock receiver as shown in *Figure 14: Transfer FINE Time from Fine Clock to Warm Clock Receiver* on the next page.
2. Issue the following command to the warm clock receiver:

```
adjust1pps mark
```

The phase of the warm clock receiver clock is adjusted by the fractional measurement of the fine clock receiver's 1 PPS mark input event. In other words, it synchronizes the warm clock receiver's 1 PPS to the incoming 1 PPS of the fine clock receiver. It does not adjust the one second TOW counter or the receiver's week number. This procedure is used to make small corrections to the warm clock receiver's clock.

Figure 14: Transfer FINE Time from Fine Clock to Warm Clock Receiver

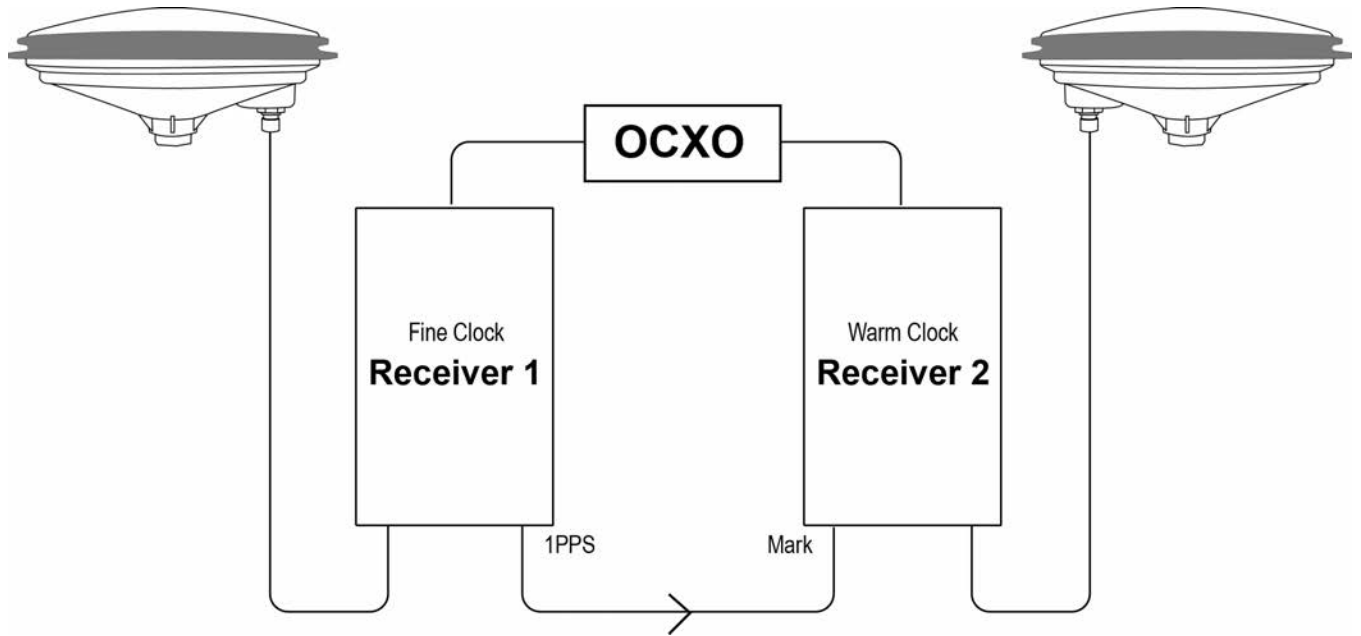

If Receiver 2 is not in coarsetime, the input is ignored.

Figure 15: 1 PPS Alignment

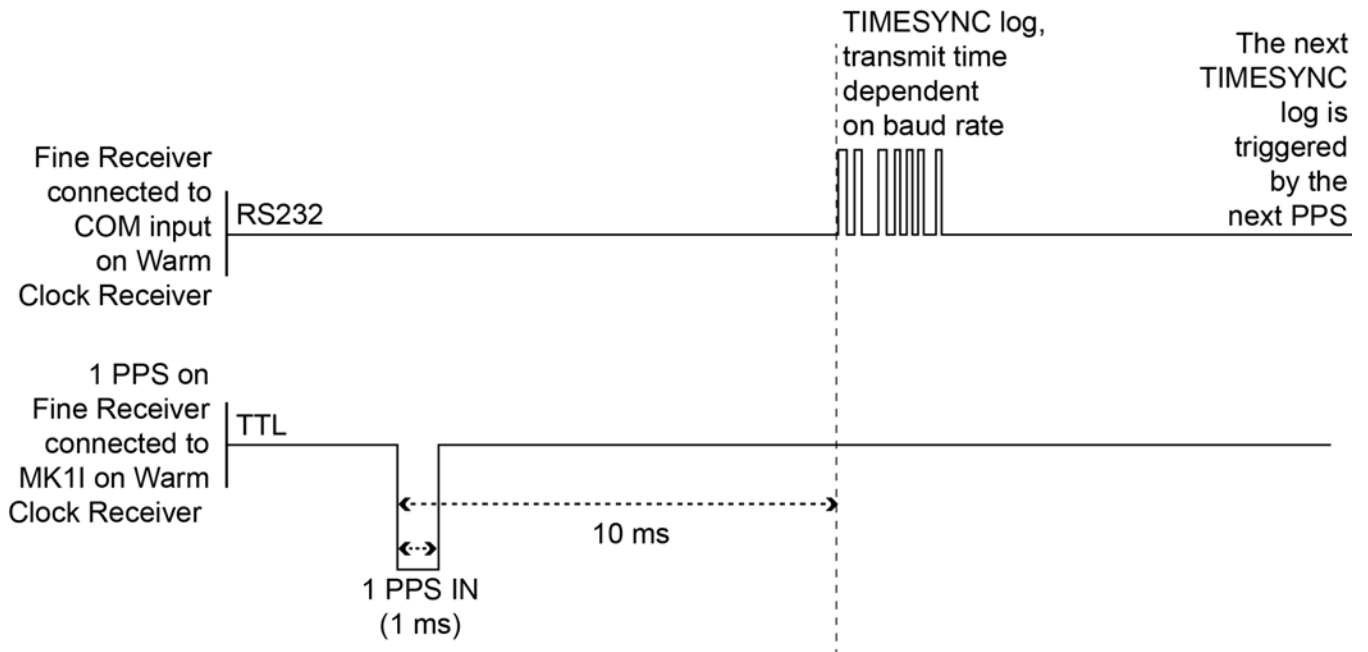

The examples shown in *Figure 12: Transfer COARSE Time from Fine Clock to Cold Clock Receiver* on page 52, *Figure 13: Transfer FINE Time from Fine Clock to Cold Clock Receiver* on the previous page and *Figure 14: Transfer FINE Time from Fine Clock to Warm Clock Receiver* above are for the transfer of time. If a position is needed, the receiver must be tracking satellites and must have a valid almanac.

3.10 Interference Toolkit

The Interference Toolkit (ITK) feature monitors, quantifies and removes interference sources to prevent interference from impacting receiver performance.

Using the Interference Toolkit, you can monitor the Radio Frequency (RF) spectrum in a range of frequencies around the GNSS signals that are being received by the OEM7 receiver. If an interference signal is detected, information about the interference is output in the **ITDETECTSTATUS** log. More information about the interference signal can be determined by plotting the information obtained.

Signals available are model dependent. A variety of mitigation techniques are available. Contact www.novatel.com/where-to-buy/sales-offices to activate full mitigation features.

3.10.1 Monitoring GNSS Signals

By default, interference detection is enabled. Detection can be disabled/enabled as needed. See *Disable/Enable Detection* on the next page for instructions. Detected interference can be viewed and different tracking modes with possible additional filters can be applied to mitigate the interference using NovAtel Connect. Detected interference details can also be logged and analyzed using the command line interface.

There are two types of interference detection available, Spectral Analysis Detection and Statistical Analysis Detection.



NovAtel recommends using the default settings for Interference Toolkit whenever possible.



NovAtel Connect 2.0 or greater is required to use Interference Toolkit functionality. Download NovAtel Connect from www.novatel.com/novatel-connect.

Spectral Analysis Detection

Spectral Analysis Detection is focused on in-band, near-band, and strong out-band interference detection.

OEM7 uses receiver gain calibration data that is stored in receiver memory at receiver start-up. The calibration data is used to estimate the antenna gain before the receiver, as well as generate interference free spectrum reference for spectral analysis detection. The receiver assumes that the receiver is in an interference free environment during start-up and the antenna is connected to the receiver and powered up.



When using the Interference Toolkit, the receiver must be reset when the GNSS antenna is connected or disconnected.



If a known interference source is present at the receiver start up, it's strongly recommended that users enter the calibrated receiver input gain using the **RFINPUTGAIN** command.

Measuring the RF Input Gain



This section is intended for advanced users.

The **RFINPUTGAIN** command allows users to enter a more accurate receiver input condition, which is considered as a calibrated receiver input condition, and is used for interference detection. This command supports different values for L1, L2, L5, and L-Band and is recommended when there is a known strong interference present at receiver start up.

To calibrate the receiver input level, use a standard spectrum analyzer to measure the receiver input noise density in dBm/Hz. Make sure the pre-amplifier is turned on in Spectrum Analyzer under “Amplitude”. Place the Marker around L1, L2, L5, or L-Band frequency region and select “noise density” under “Marker Function”.

$RFINPUTGAIN = \text{Receiver Input Noise Density (dBm/Hz)} - \text{Typical Thermal Noise KT of } -174\text{dBm/Hz}$,
where:
 $K = 1.38E-23\text{w-sec/K}$
 $T = 290\text{ k}$.

For example, if the receiver input noise density measured at L1 is -144dBm/Hz,

$RFINPUTGAIN = -144 - (-174) = 30\text{dB}$ for L1 path.

Alternatively, if a spectrum analyzer is not available, the RFINPUTGAIN can be obtained using the cascaded RF gain before the receiver plus LNA noise figure (NF), including LNA gain in antenna, in-line amplifier gain (if applicable), RF cable or distribution loss prior to receiver input connector. A typical GNSS active antenna with reasonable quality has a noise figure of ~2dB.

$RFINPUTGAIN = \text{Cascaded Gain before receiver} + \text{LNA NF}$

For example, if system cumulative gain measured before receiver is ~25dB, and LNA NF is around 2dB, the RFINPUTGAIN = 27dB.

```
RFINPUTGAIN L1 27
```

```
RFINPUTGAIN L2 27
```

```
RFINPUTGAIN L5 27
```

```
RFINPUTGAIN LBand 27
```

Statistical Analysis Detection

Statistical Analysis Detection is focused on out of band interference detection. It is supplementary to the Spectrum Analysis Detection and is useful when interference is outside the analog passband of the receiver and creating distortion that may not be visible to Spectrum Analysis Detection until the interference is very strong.

The Statistical Analysis Detection is designed as a sensitive detection tool. Out of band mitigation does not impose much penalty when enabled and it brings awareness to unintentional interferences next to GNSS operations.



Spectral Analysis Detection takes precedent over Statistical Analysis Detection. If the same interference is detected by both detectors, only Spectral Analysis Detection is used to report the interference status.

3.10.2 Disable/Enable Detection

The interference detection feature can be enabled/disabled from any command line or the command line within NovAtel Connect using the **ITDETECTCONFIG** command.

To disable interference detection, enter:

```
ITDETECTCONFIG none
```

To enable interference on all RF paths, enter :

```
ITDETECTCONFIG all
```

Interference detection can also be enabled on individual RF paths. See the **ITDETECTCONFIG** command for details.

3.10.3 Monitoring Signals Using a Command Line

The **ITDETECTSTATUS** log lists all detected interference signals. For interference detected by spectral analysis, the log also provides the center frequency and bandwidth of the interference signal. With this information, a filter can be configured to mitigate the interference.



Due to the high volume of data, a higher bandwidth medium, such as USB or Ethernet, is recommended when monitoring signals using the Interference Toolkit.

Example:

```
LOG ITDETECTSTATUS onchanged

#ITDETECTSTATUSA, USB2, 0, 74.0, FINESTEERING, 1982, 430605.267, 0200c000,
7fdb, 32768;3,
L1, STATISTICANALYSIS, -0.718, 29.167, 0.126, 12.797, 00000000, 00000000,
00000000,
L2, SPECTRUMANALYSIS, 1249.961, 71.191, -56.769, -132.907, 00000000,
00000000, 00000000,
L2, SPECTRUMANALYSIS, 1289.512, 1.978, -75.967, -138.493, 00000000,
00000000, 00000000*5e83b175
```

In the above example, there are three interference signals detected:

- Out of band interference near L1 (STATISTICANALYSIS)
- Interference in the L2 band at 1249.961 MHz
- Interference in the L2 band at 1289.512 MHz

To view details about the signals that are being received by the OEM7 receiver and determine if there is an interference signal within the GNSS signals, use the **ITSPECTRALANALYSIS** command to enable and configure the spectral analysis. The spectrum can then be viewed by plotting the PSD samples in the **ITPSDFINAL** log. NovAtel Connect can also be used to view the spectrum. See *Monitoring Signals Using NovAtel Connect* on the next page.

Example:

```
ITSPECTRALANALYSIS PREDECIMATION GPSL1 200 2K 1 1

LOG ITPSDFINAL onnew
```

When logged, incoming signal information is collected at the rate specified in the **ITSPECTRALANALYSIS** command.



Pre-decimation – Raw analog-to-digital converter signals.

Post-decimation — Analog-to-digital converted signal for the specific signal encoder path. This gives a narrower view of the incoming signal.

3.10.4 Monitoring Signals Using NovAtel Connect



Due to the high volume of data, a higher bandwidth medium, such as USB or Ethernet, is recommended when monitoring signals using the Interference Toolkit.

Start NovAtel Connect and open a connection to the OEM7 receiver.

Scroll down to the Interference Toolkit and double-click on the Interference Toolkit tile.

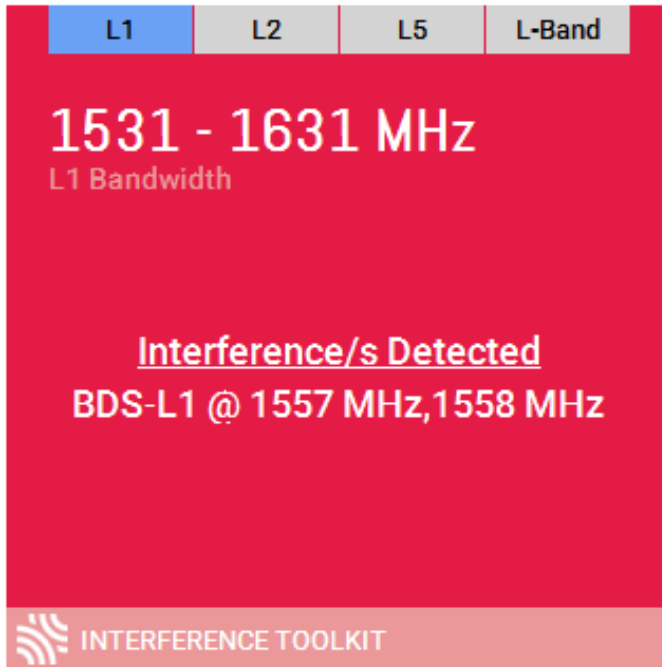

The tile displays red when interference is detected; displays green when no interference is present.

The Interference Toolkit window opens. The following example shows a typical signal.

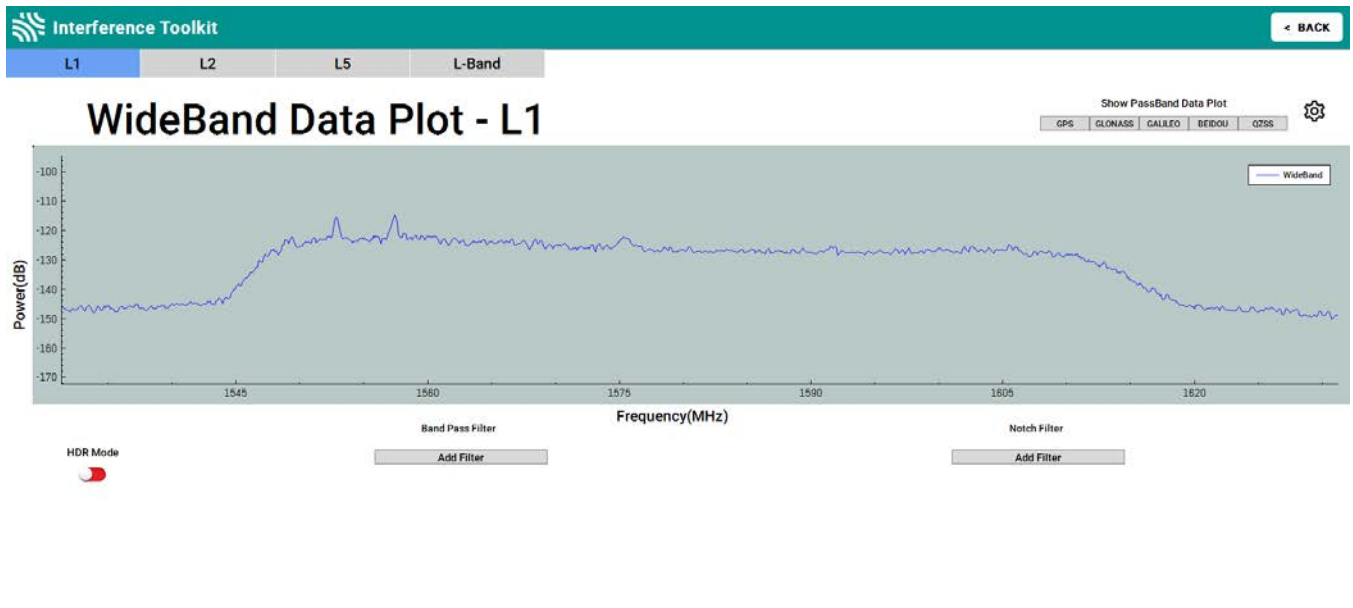

Placing the cursor over any place in the signal band will display additional information regarding that location in the signal band.

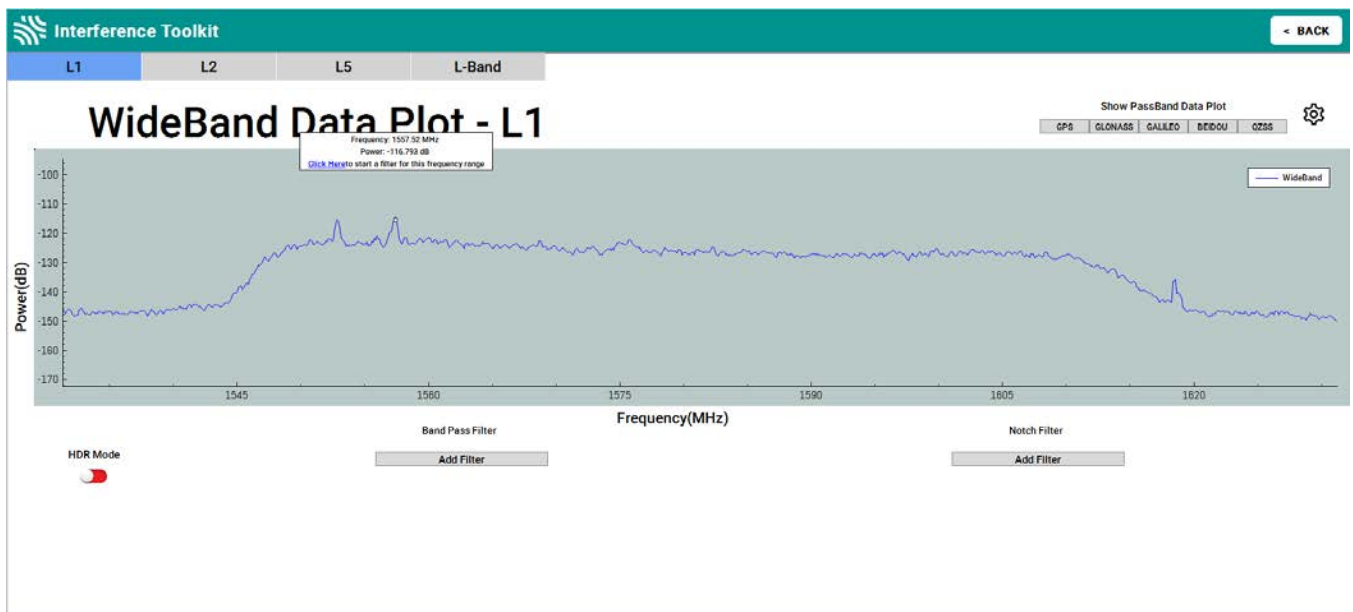

3.10.5 Remove Interference Signals

If an interference signal is present, the Interference Toolkit can reduce or eliminate the impact on GNSS tracking using the programmable High Dynamic Range (HDR), Bandpass or Notch filters.

Contact www.novatel.com/where-to-buy/sales-offices to obtain mitigation functionality.

High Dynamic Range Mode

The High Dynamic Range (HDR) mode enables special signal processing to remove distortions from the spectrum, providing a cleaner signal. This optimizes the Automatic Gain Control (AGC) to prevent interfering signals from drowning out the GNSS signals. HDR mode works well against wide band and out-of-band interferers. HDR mode can be combined with bandpass and notch filters, but does draw more power.

To configure HDR mode, use the **ITFRONTENDMODE** command. HDR mode can also be enabled using NovAtel Connect.

Notch Filter

The Interference Toolkit notch filter reduces the signal power in a narrow frequency band. This type of filter is useful for reducing the signal power of a single, narrow band interference signal. Note that the narrowest possible filter should be used to maintain the maximum amount of overall signal power.

To configure a notch filter, use the **ITPROGFILTCONFIG** command. A notch filter can also be configured using NovAtel Connect.

Bandpass Filter

The Interference Toolkit bandpass filter reduces the signal power of all incoming signals at the upper and lower end of the GNSS signal band starting at the requested cut-off frequency. This type of filter is good for reducing single or multiple interference signals at the edges of the signal band.

When a bandpass filter is applied to this signal, the upper and lower ends of the signal band are filtered out to reduce the signal power of the interference signal.

To configure a bandpass filter, use the **ITPROGFILTCONFIG** command or the **ITBANDPASSCONFIG** command. A bandpass filter can also be configured using NovAtel Connect.

Example of a Notch Filter

The following example shows interference at 1750 in the signal band.

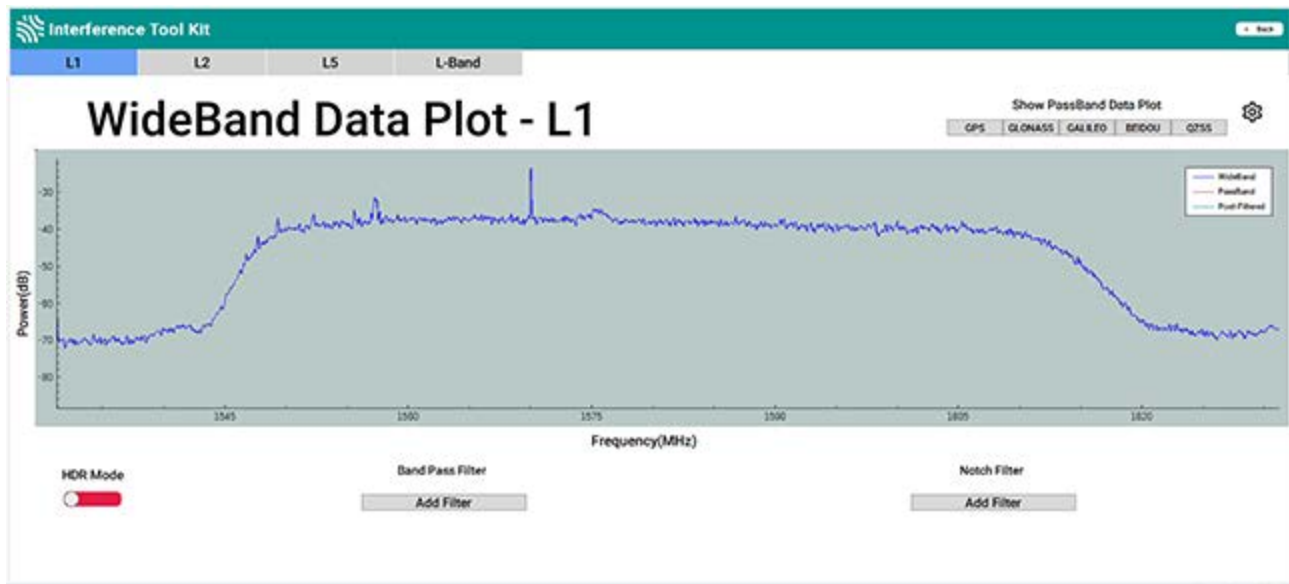

The following example shows post filtering with interference.

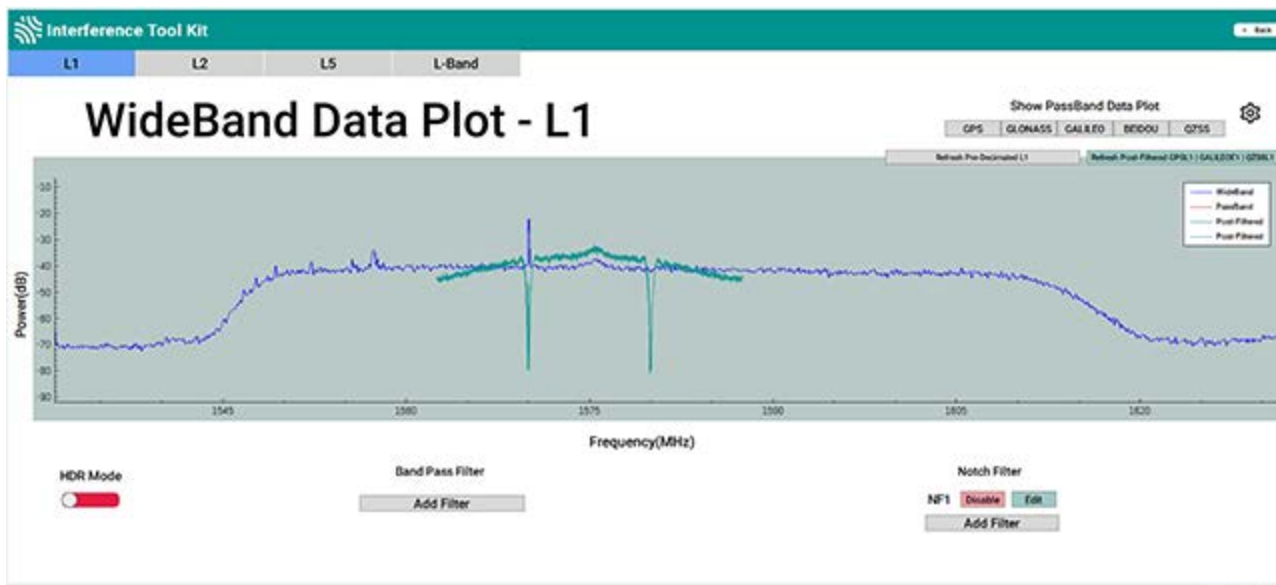

Interference Toolkit Commands and Logs

The following are the commands and logs used by the Interference Toolkit to monitor, apply filters and mitigate interference. Commands and logs with the ✓ are available by default. Contact www.novatel.com/where-to-buy/-sales-offices to activate full mitigation features.

Commands		
ITBANDPASSCONFIG		Configures a bandpass filter on the receiver.
ITDETECTCONFIG	✓	Enables or disables automatic interference detection on the receiver.
ITFRONTENDMODE		Configures the front end mode for each RF path to use the default tracking mode or change to High Dynamic Range (HDR) mode.
ITPROGFILTCONFIG		Configures filtering on the receiver to be either a notch filter or a bandpass filter.
ITSPECTRALANALYSIS	✓	Configures and enables spectral analysis on the receiver.

Logs		
ITBANDPASSBANK		Provides the allowable bandpass filter configurations.
ITDETECTSTATUS	✓	Lists all of the interference detected on the paths on which automatic interference detection has been enabled.
ITFILTTABLE		Summarizes the filter configuration for each frequency and indicates which bandpass or notch filters are enabled and configured.
ITPROGFILTBANK		Provides the allowable programmable filter configurations.
ITPSDFINAL	✓	Provides the power spectral density information of the specified signal path.

3.11 Logging and Retrieving Data Overview

Logs can be directed to any of the receiver communication ports and can be automatically generated at regular intervals or when new or changed data becomes available.

Data can be collected using NovAtel Connect or NovAtel Web User Interface. Refer to the Help available from within NovAtel Connect for comprehensive logging instructions. Refer to the online OEM7 documentation (docs.novatel.com/OEM7) for information about logging using NovAtel Web User Interface.



NovAtel Connect version 2.0 or greater is required for OEM7 receivers. Download the latest NovAtel Connect software and documentation from www.novatel.com/novatel-connect.

3.11.1 Pass-Through Logging

The pass-through logging feature enables the GNSS receiver to redirect any ASCII or binary data that is input at a specified COM port or USB port, to any specified receiver COM or USB port. This capability, in conjunction with the SEND command, allows the receiver to perform bidirectional communications with other devices such as a modem, terminal or another receiver.

There are several pass-through logs available on OEM7 receivers for logging through serial ports. Refer to the PASSCOM logs in the [OEM7 Commands and Logs Reference Manual](#) for details.

3.12 Additional Features and Information

The following sections contain information on additional features of the OEM7 receivers.

- *Strobes* below

3.12.1 Strobes

OEM7 receivers have inputs and outputs, referred to as strobes, that provide status and synchronization signals. Not all strobes are provided on all receivers. For detailed information about OEM7 receiver strobes, see:

- *SPAN CPT7 Strobe Specifications* on page 149

Chapter 4 SPAN Operation

Before operating your SPAN system, ensure that you have followed the installation and setup instructions in *SPAN CPT7 Installation* on page 22.

You can use the NovAtel Connect software to configure receiver settings and to monitor data in real-time, between a rover SPAN system and base station.

SPAN system output is compatible with post-processing software from the NovAtel Waypoint Products Group. Visit our web site at www.novatel.com for details.



Ensure the Control Panel Power Settings on your computer are not set to go into Hibernate or Standby modes. Data will be lost if one of these modes occurs during a logging session.

4.1 Definition of Reference Frames Within SPAN

The reference frames that are most frequently used throughout the SPAN documentation are the following:

- *The Local-Level Frame (ENU)* below
- *The IMU Body Frame* on the next page
- *The Vehicle Frame* on page 65
- *The User Output Frame* on page 65

4.1.1 *The Local-Level Frame (ENU)*

The definition of the local level coordinate frame is as follows:

- z-axis – pointing up (aligned with gravity)
- y-axis – pointing north
- x-axis – pointing east

Figure 16: Local-Level Frame (ENU)

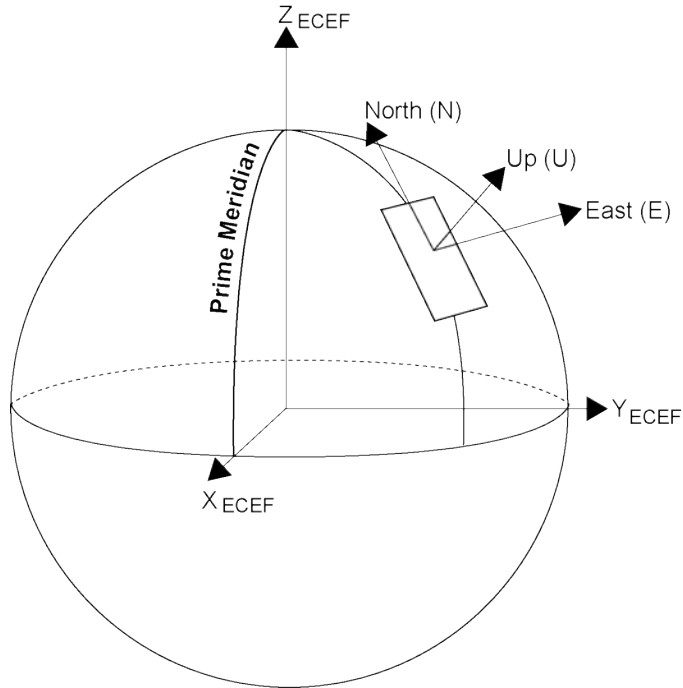

4.1.2 The IMU Body Frame

The definition of the IMU Body frame is given by the physical axes of the IMU and represents how the sensors are mounted inside the IMU. The IMU Body frame axes are marked on the SPAN CPT7. Refer to *SPAN CPT7 Mechanical Specifications* on page 143 for illustrations of the IMU Body frame axes.



The axis marking on the SPAN CPT7 indicates the orientation of the X, Y and Z axis only. It does not indicate the center of navigation. For the location of the center of navigation, refer to *Figure 40: SPAN CPT7 Center of Navigation* on page 145.

The origin of this frame is not the enclosure center, but the center of navigation (sensor center).

Figure 17: IMU Body Frame Marking

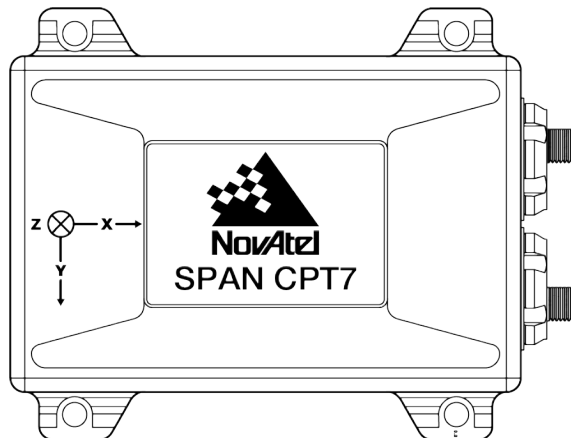

4.1.3 The Vehicle Frame

The definition of the vehicle frame is as follows:

- z-axis – points up through the roof of the vehicle perpendicular to the ground
- y-axis – points out the front of the vehicle in the direction of travel
- x-axis – completes the right-handed system (out the right-hand side of the vehicle when facing forward)

Figure 18: Vehicle Frame

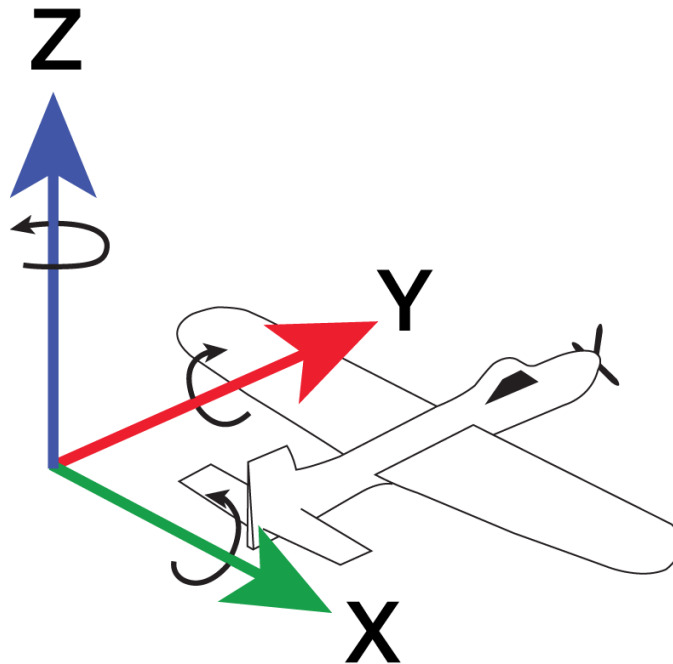

4.1.4 The User Output Frame

The user output frame is an arbitrary frame, which can be optionally defined to transfer inertial output to a more useful position or reference frame.

By default, SPAN position and velocity output is given at the center of navigation of the IMU. To output position and velocity at a different location, specify a user offset translation using the **SETINSTRANSLATION** command.

By default, SPAN attitude output is the rotation from the Local-Level frame to the Vehicle frame. If attitude output is desired relative to another frame, specify a user offset rotation using the **SETINSROTATION** command.

4.2 SPAN Translations and Rotations

A SPAN system combines GNSS and INS into a single system. In a GNSS system, the position is reported relative to the phase center of the GNSS antenna. In an INS system, the position, velocity and attitude data is reported relative to the center of navigation of the IMU. For a SPAN system to provide a combined GNSS+INS position, velocity and attitude, it must know where the GNSS antenna is positioned relative to the IMU.

The orientation of the IMU relative to the forward direction of the vehicle is also needed to convert the velocity and attitude changes sensed by the IMU into the actual motion of the vehicle.

If the SPAN system incorporates other devices, such as a camera connected to an Event Input, the SPAN system also needs to know the location and orientation of these additional devices relative to the IMU.

4.2.1 Translational Offsets

The three dimensional distances between the IMU and other SPAN components are called translational offsets.

The translational offsets are measured in three directions, X axis, Y axis and Z axis, typically relative to the IMU Body frame. Translational offsets can also be entered relative to the Vehicle frame.



The X, Y and Z axes of the IMU Body frame are typically indicated on the IMU enclosure. The X, Y and Z axes of the IMU Body frame are also indicated on the mechanical drawings of the IMUs in the *SPAN CPT7 Mechanical Specifications* on page 143.

Figure 19: IMU to Antenna Translation Offset below shows an example of the translational offsets from the IMU to a GNSS antenna. In this example, the IMU Body Frame (indicated by the small arrows) has the Y axis pointing in the direction of the vehicle motion and the z axis pointing up.

Figure 19: IMU to Antenna Translation Offset

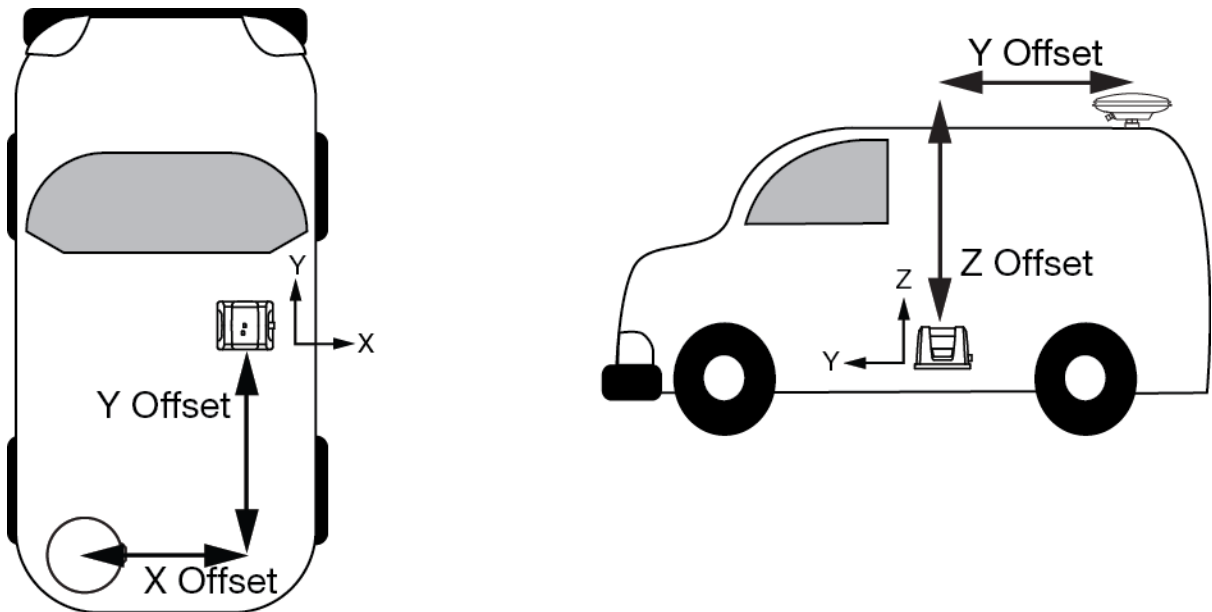

If the distances measured in this example were X Offset = 1.000 m, Y Offset = 1.500 m and Z Offset = 2.000 m, the following values would be entered, based on the IMU Body Frame:

- $x = -1.000$
- $y = -1.500$
- $z = 2.000$

The translational offsets are entered using the **SETINSTRANSLATION** command. For this example, the command to enter these offsets is:

```
SETINSTRANSLATION ANT1 -1 -1.5 2
```



The measurements for the translational offsets should be done as accurately as possible, preferably to within millimeters especially for RTK operation. Any error in the offsets will translate into an error in the INS position.

The translational offsets from the IMU to the GNSS antenna are required for all SPAN systems. However, some SPAN systems may have other sensors or devices integrated into the system for which the SPAN needs translational offsets. For example, a gimbal mount or a camera or LiDAR connected to an Event Input line. The offsets to these additional sensors and devices are also entered using the **SETINSTRANSLATION** command.

By default, the translational offsets are entered in the IMU Body Frame. However, in some systems the IMU Body Frame may not be known precisely. For these cases, the **SETINSTRANSLATION** command has an option that allows the offsets to be entered relative to the Vehicle Frame. In these cases, the rotation from the IMU Body Frame to the Vehicle Frame (RBV) is used to rotate offsets into the default IMU Body frame as required. To achieve the best results, this means that the RBV rotation must be known very precisely. Typically this is achieved through the SPAN RBV Calibration procedure. See *Body to Vehicle Frame Rotation Calibration Routine* on page 82 or *Multi-Line Body to Vehicle Frame Rotation Calibration Routine* on page 82 for information about this calibration procedure.

4.2.2 Rotational Offsets

The differences in orientation between the IMU and other SPAN components are called rotational offsets. Rotational offsets are given as the rotation from the IMU Body Frame to the frame of interest.



The order of rotations is Z-X-Y and all rotations are right handed.

Generally, frames of reference are defined as Z up, with Y forward, and X completing the right-handed system. An example is the vehicle frame, where Z is always considered to be upwards, Y forward through the direction of travel, and X to the right.

Rotational Offsets - Example

Consider an IMU installed in the following way:

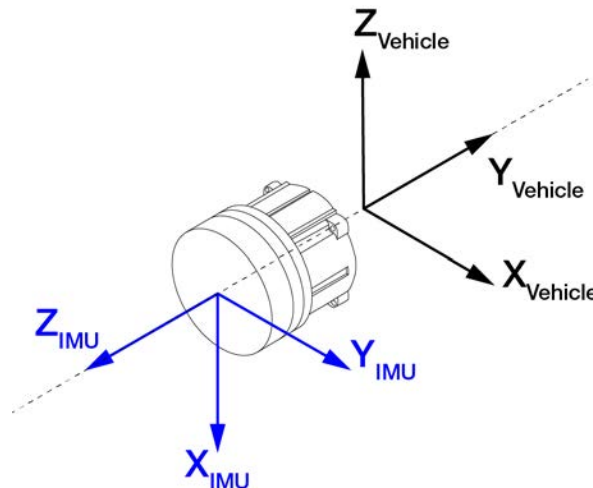

Here, the Euler Angles to rotate from the IMU Body frame to the Vehicle frame (RBV) are:

- X: -90
- Y: 0
- Z: +90

To reach this answer, keep in mind the following rules:

- The goal is to rotate the IMU Body frame to be coincident with the Vehicle frame (i.e. IMU X equals Vehicle X, IMU Y equals Vehicle Y, IMU Z equals Vehicle Z).
- You must rotate from the IMU Body frame to the Vehicle frame.
- You must rotate in the order Z, X, Y.
- Positive rotation is defined according to the right hand rule.

Z Rotation:

Observe that if a positive 90 degree rotation is performed about the IMU Z axis, the rotated IMU X axis becomes collinear with the Vehicle X axis.

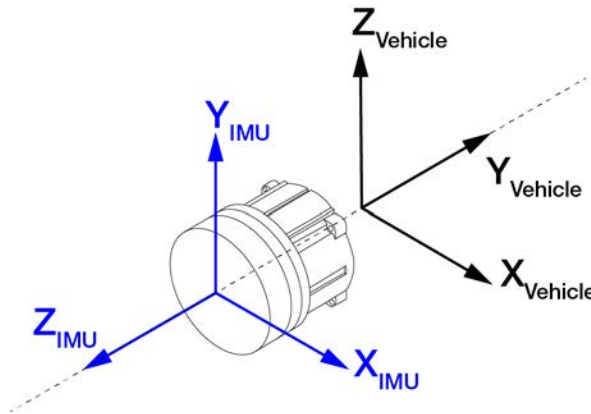
**X Rotation:**

Observe that if a negative 90 degree rotation is performed about the new IMU X axis, the rotated IMU Y axis is now collinear with the Vehicle Y axis, and the rotated IMU Z axis is also collinear with the Vehicle Z axis.

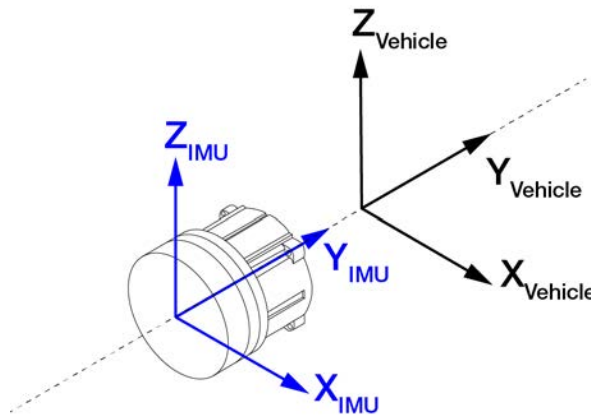
**Y Rotation:**

Since all three sets of axes are already collinear, our frames are coincident, and no further rotation is required.



This solution is not unique. Due to the properties of Euler Angles, there are usually multiple sets of equivalent rotations.

The rotational offsets are entered using the **SETINSROTATION** command. For this example, the command to enter the rotations for the previous example is:

```
SETINSROTATION RBV -90 0 90
```

4.3 Software Configuration

On a SPAN system, both the GNSS receiver and the IMU must be configured.

4.3.1 GNSS Configuration

The GNSS configuration can be set up for different accuracy levels such as single point, SBAS, DGNSS, PPP and RTK. Refer to *OEM7 Receiver Operation* on page 36 for information about configuring the GNSS settings.

With no additional configuration, the system operates in single point mode.

4.3.2 INS Profiles

INS Profiles provide two major functions; simplified configuration and enhanced performance. Each INS Profile sets specific filter behavior to enhance system performance in particular environments.

Basic enhancements provided by the INS Profiles are available to all SPAN enabled models and allow for simple configuration rather than sending many discreet commands.

The enhanced profile settings are enabled by the receiver model. The enhanced profile adds enhanced profile behavior such as Dead Reckoning for land and Heave for marine. A receiver model with an INS Mode of **P** or **R** is required to enable Enhanced INS Profiles.

Table 5: OEM7 INS Profiles

Profile	Description	Basic Profile Settings	Enhanced Profile Settings
DEFAULT	The default SPAN profile. This profile has legacy SPAN default settings.	None	N/A
LAND	INS Profile for fixed axle land vehicles. Enables robust kinematic alignment routines and configures the update profile.	Enables direction detection on kinematic alignment routine Enables course over ground attitude updates	Enables intelligent vehicle dynamics modeling for land vehicles (Dead Reckoning)
MARINE	INS profile for marine vessels. Enacts changes to disable static behavior and make the marine solution more robust.	Disable Zero Velocity Updates Disable turn-on bias estimation	Enables Heave algorithms
FIXEDWING	INS profile for fixed wing aircraft	None	None
FOOT	INS profile for walking or backpack applications	None	None
VTOL	INS profile for Vertical Take Off and Landing aircraft (helicopter, quadcopter, etc.)	None	None

Profile	Description	Basic Profile Settings	Enhanced Profile Settings
RAIL	INS profile for railway applications	Enable direction detection on kinematic alignment routine Enable course over ground attitude updates	Enables intelligent vehicle dynamics modeling for rail vehicles (Dead Reckoning)
AGRICULTURE	INS profile for agriculture applications	Enables direction detection on kinematic alignment routine Enables course over ground attitude updates	Enables intelligent vehicle dynamics modeling for agricultural vehicles (Dead Reckoning)

Use

To use an INS Profile, send the **SETINSPROFILE** command at startup (or save to NVM) to activate the mode. For example:

```
SETINSPROFILE LAND
```

The type of profile activated, basic or enhanced, is determined by the SPAN model.



The currently selected profile option is available in the **INSCONFIG** log.

RBV Calibration

For the profiles to provide the greatest benefit, the rotation offset of the IMU body to the vehicle frame (RBV) should be known as accurately as possible. Since constraints happen at the vehicle level, any error in the offset will translate into worse performance. These parameters are estimated in the background when the system is fully converged, however it is always better to have this measured as precisely as possible before mission critical data is collected.

The INSCALIBRATE RBV functionality can be used to estimate and save these offsets to NVM in a controlled manner.

4.3.3 SPAN Configuration for SPAN CPT7

- *Minimum Recommended Configuration* below
- *Configure SPAN Manually* on the next page
- *SPAN Configuration with NovAtel Connect* on page 73
- *SPAN Configuration with NovAtel Web User Interface* on page 73

Minimum Recommended Configuration

When configuring your SPAN CPT7 system for first time use, the following is the minimum amount of information required to ensure proper operation of a SPAN system.

Required Information	Required Command
IMU to primary antenna lever arm	SETINSTRANSULATION ANT1
IMU to secondary antenna lever arm	SETINSTRANSULATION ANT2
IMU to vehicle frame rotation	SETINSROTATION RBV

While this is the minimum amount of information required, additional information is typically needed for SPAN systems. The following commands are commonly used to configure SPAN systems.

Common User Settings	Appropriate Command	Notes
IMU to output position offset	SETINSTRANSULATION USER	Default output position is at the IMU center
IMU to output frame rotation	SETINSROTATION USER	Default output frame is the vehicle frame
Vehicle type	SETINSPROFILE	
Minimum alignment velocity	SETALIGNMENTVEL	

Configure SPAN Manually

Follow these steps to enable INS as part of the SPAN CPT7 system using software commands:



A GNSS antenna with a clear view of the sky must be connected and tracking satellites for operation.

1. Issue the **SETINSTRANSULATION** command, using the **ANT1** parameter, to enter the distance from the SPAN CPT7 to the primary GNSS antenna.

Issue the **SETINSTRANSULATION** command, using the **ANT2** parameter, to enter the distance from the SPAN CPT7 to the secondary GNSS antenna.

See the **SETINSTRANSULATION** command in the [OEM7 Commands and Logs Reference Manual](#) for more information.

The offset between the antenna phase center and the IMU axis must remain constant and be known accurately (m). The X, Y and Z directions are clearly marked on the SPAN CPT7 enclosure. The SETINSTRANSULATION parameters are (where the standard deviation fields are optional and the distances are measured from the SPAN CPT7 to the antenna):

```
ANT1 x_offset y_offset z_offset [x_stdev] [y_stdev] [z_stdev]
```

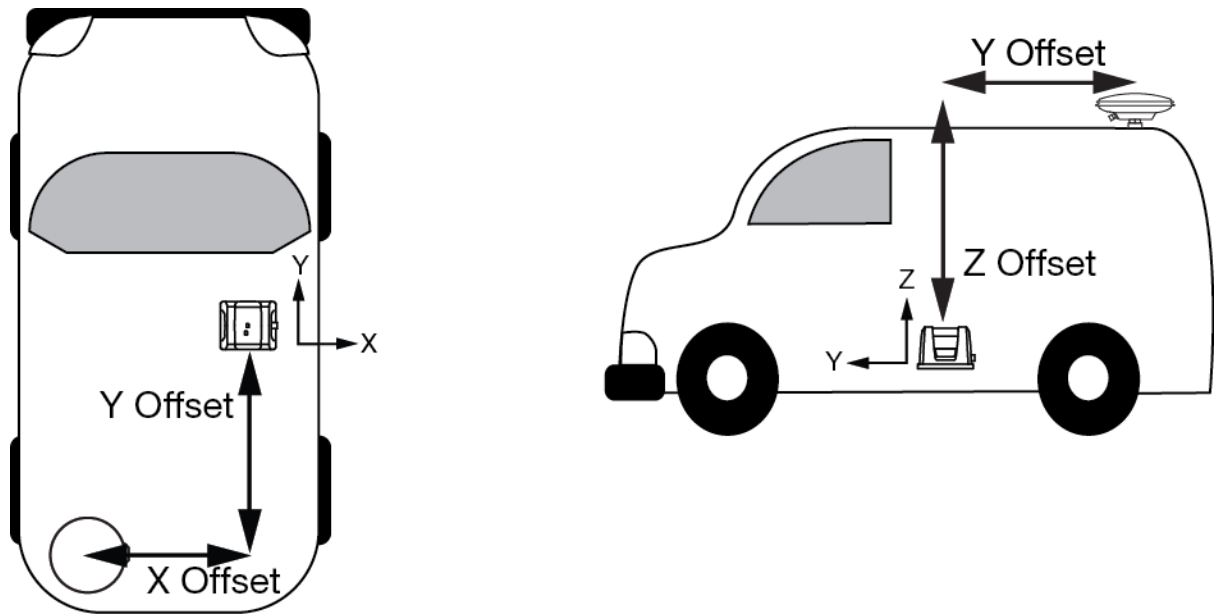

This example shows a mounting configuration with a negative X offset, negative Y offset and positive Z offset.



The axis marking on the SPAN CPT7 indicates the orientation of the X, Y and Z axis only. It does not indicate the center of navigation. For the location of the center of navigation, refer to *Figure 40: SPAN CPT7 Center of Navigation* on page 145.

A typical RTK GNSS solution is accurate to a few centimeters. For the integrated GNSS+INS system to have this level of accuracy, the offset must be measured to within a centimeter. Any offset error between the two systems shows up directly in the output position. For example, a 10 cm error in recording this offset will result in at least a 10 cm error in the output.

- Issue the **SETINSROTATION** command, using the **RBV** parameter, to enter the Euler Angle rotation from the IMU Body frame to the Vehicle frame. See the **SETINSROTATION** command in the [OEM7 Commands and Logs Reference Manual](#) for more information.

Accurate knowledge of the rotational offset between the IMU Body frame and the Vehicle frame (the RBV rotation) is critical to correctly computing an attitude solution, and is required before a Kinematic alignment is possible.

The SETINSROTATION parameters are (where the standard deviation fields are optional):

```
RBV x_rotation y_rotation z_rotation [x_stddev] [y_stddev] [z_stddev]
```



The order of rotations is Z-X-Y. All rotations are right handed.

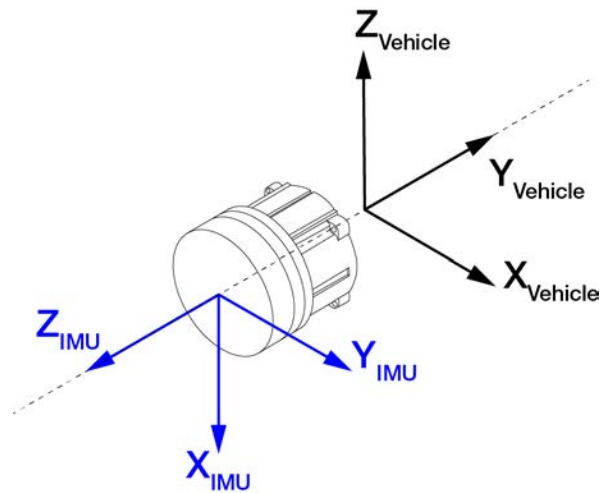

For an example of how to solve for the IMU Body to Vehicle frame rotation refer to *Rotational Offsets* on page 67.

If the rotation between the IMU Body frame and the Vehicle frame is not precisely known, enter an approximate rotation (to the nearest 45 degrees). The precise offset can be estimated by carrying out the *Body to Vehicle Frame Rotation Calibration Routine* on page 82.

SPAN Configuration with NovAtel Connect

NovAtel Connect provides a wizard that takes you through the steps required to configure a SPAN system. For information about using the SPAN Configuration wizard in NovAtel Connect, refer to the help file available within NovAtel Connect.



NovAtel Connect version 2.0 or greater is required for OEM7 receivers. Download the latest NovAtel Connect software and documentation from www.novatel.com/novatel-connect.

SPAN Configuration with NovAtel Web User Interface

The SPAN parameters can be configured using the NovAtel Web User Interface. For information about using the NovAtel Web User Interface, refer to the online OEM7 documentation (docs.novatel.com/OEM7).

4.3.4 Importance of RBV Calibration

For the SPAN system to provide the best performance, the rotation offset of the IMU body to the Vehicle frame (RBV) should be known as accurately as possible. Since constraints happen at the vehicle level, any error in the offset will translate into worse performance.

After the SPAN system has been installed and the appropriate translations and rotations have been applied (see *SPAN Configuration for SPAN CPT7* on page 70), the IMU Body frame is aligned with the Vehicle frame. However, aspects of the mounting platform and vehicle design, such as vehicle tilt, and slight misalignments in installation can cause the IMU Body frame to be slightly out of alignment with the Vehicle frame. The misalignment of the IMU Body frame from the Vehicle frame will add a bias to the SPAN solution.

The following diagrams show examples of a SPAN CPT7 installed in a vehicle with misalignment issues.

Figure 20: Rear View of SPAN CPT7 – Mounting Plate is not Flat

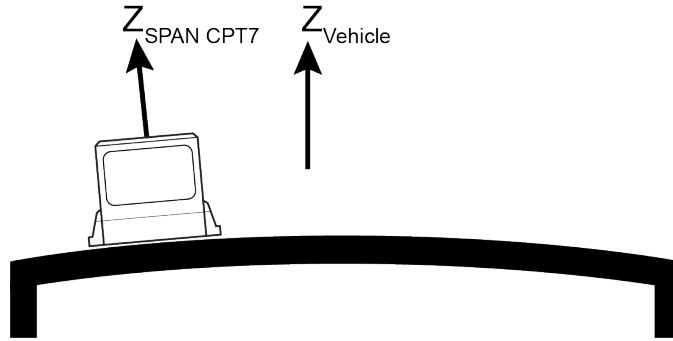

Figure 21: Side View of SPAN CPT7 – Vehicle is not Level

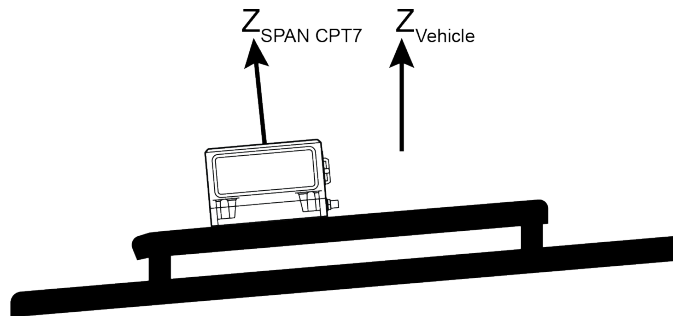
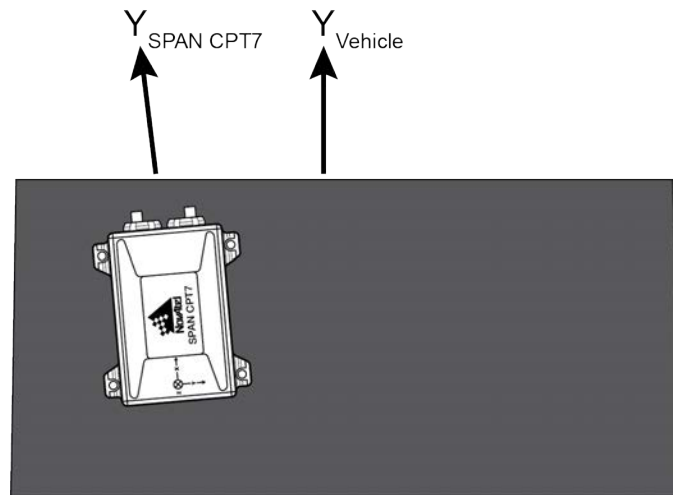

Figure 22: Top View of SPAN CPT7 – SPAN CPT7 Misalignment



The misalignments shown in the previous figures have been exaggerated for illustration purposes.

In a typical SPAN system installation, the slight misalignments shown in the examples above are hard to detect and difficult to measure. For this reason, it is recommended that a Body to Vehicle Frame rotation calibration routine be used so the SPAN system can determine and compensate for these angles. Refer to *Body to Vehicle Frame Rotation Calibration Routine* on page 82 or *Multi-Line Body to Vehicle Frame Rotation Calibration Routine* on page 82 for more information.

These parameters are estimated in the background when the system is fully converged, however it is always better to have this measured as precisely as possible before mission critical data is collected.



Since slight variations in alignment can be introduced when the SPAN CPT7 is remounted, a Body to Vehicle Frame calibration should be performed each time the device is remounted.



An accurate RBV is especially important if the position is being transferred to a user offset.

4.4 Real-Time Operation

SPAN operates through the OEM7 command and log interface. Refer to the [OEM7 Commands and Logs Reference Manual](#) log and command details. .

Real-time operation notes:

- By default, raw IMU data will begin to output as soon as the IMU is connected. However an initial position is required to begin the INS alignment process. This position is typically set by GNSS. The GNSS position will not be used until the FINESTEERING time status is reached. This requires a GNSS antenna connected with a clear view of the sky. See *System Start-Up and Alignment Techniques* on the next page for more details.
- The inertial solution is computed separately from the GNSS solution. The GNSS solution is available from the SPAN system through the GNSS-specific logs, even without SPAN running. The integrated GNSS+INS solution is available through special INS logs documented in INS Logs in the [OEM7 Commands and Logs Reference Manual](#).
- The IMU raw data is available at the maximum rate of output of the IMU. Because of this high data rate, a shorter header format was created. These shorter header logs are defined with an S (RAWIMUSXB rather than RAWIMUXB). We recommend you use these logs instead of the standard header logs to save throughput on the COM port.

Status of the inertial solution can be monitored using the inertial status field in the INS logs, see *Table 6: Inertial Solution Status* below.

Table 6: Inertial Solution Status

Binary	ASCII	Description
0	INS_INACTIVE	IMU logs are not yet present or the alignment routine is not yet initialized. INS state is inactive.
1	INS_ALIGNING	INS is in alignment mode.
2	INS_HIGH_VARIANCE	The INS solution uncertainty contains outliers and the solution may be outside specifications. The solution is still valid but you should monitor the solution uncertainty in the INSSTDEV log. It may be encountered during times when GNSS is absent or poor.

Binary	ASCII	Description
3	INS_SOLUTION_GOOD	The INS solution is in navigation mode and has converged sufficiently to be within specifications. For a more rigorous check of the INS solution, examine bit 6 of the Extended Solution Status word. The Extended Solution Status word is available in several logs, including INSATTX log, INSPOX log, INSSTDEV log, INSSTDEVS log, INSVELX log and INSUPDATESTATUS log
6	INS_SOLUTION_FREE	The INS filter is in navigation mode and the GNSS solution is suspected to be in error. This may be due to multipath or limited satellite visibility. The inertial filter has rejected the GNSS position and is waiting for the solution quality to improve.
7	INS_ALIGNMENT_COMPLETE	The INS filter is in navigation mode, but not enough vehicle dynamics have been experienced for the system to be within specifications.
8	DETERMINING_ORIENTATION	INS is determining the IMU axis aligned with gravity.
9	WAITING_INITIALPOS	The INS filter has determined the IMU orientation and is awaiting an initial position estimate to begin the alignment process.
10	WAITING_AZIMUTH	The INS filter has determined the IMU orientation, received an initial position and completed initial bias estimates. Azimuth input (from vehicle motion, dual antenna or command) is required for alignment.
11	INITIALIZING_BIASES	The INS filter has determined the IMU orientation, received an initial position and is conducting an initial IMU bias estimate.
12	MOTION_DETECT	Vehicle motion has been detected during the alignment procedure.

4.4.1 System Start-Up and Alignment Techniques

The system requires an initial position, velocity and attitude estimate to start the navigation filter. This is called system alignment. On start-up, the system has no position, velocity or attitude information. When the system is first powered up, the following sequence of events happens:

1. The first satellites are tracked and coarse time is solved.
2. Enough satellites are tracked to compute a position.
3. Receiver “fine time” is solved, meaning the time on board the receiver is accurate enough to begin timing IMU measurements.
4. The INS Status field changes from **INS_INACTIVE** through **DETERMINING_ORIENTATION** and **WAITING_INITIALPOS**.
5. Once a GNSS position is available, an initial IMU bias estimate is conducted. During this period, the INS Status field reports **INITIALIZING_BIASES**.
6. After the bias estimate is complete, the coarse alignment routine starts. Bias estimates will be refined and a static alignment completed, if IMU quality allows. During this period the INS Status field reports **INS_ALIGNMENT**.

7. If static coarse alignment is not possible or is locked out by command, the system will require an external azimuth input, either from vehicle motion, dual antenna input or command input. While in this state the INS Status field reports WAITING_AZIMUTH.

If vehicle movement is detected, any ongoing static coarse alignment will be reset, and the INS Status field will report MOTION_DETECT.
8. After an alignment is completed, the INS Status field changes to INS_ALIGNMENT_COMPLETE. The system transitions to navigation mode.
9. The solution is refined using updates from GNSS. Once the system is operating within specifications and after some vehicle movement, the INS Status field changes to INS_SOLUTION_GOOD. This indicates that the INS filter has successfully converged to within performance specifications.

Kinematic Alignment

The kinematic or moving alignment is performed by estimating the heading from the GNSS velocity vector and injecting it into the SPAN filter as the initial system heading.

For the kinematic alignment routine to work optimally, the course-over-ground azimuth must not include any bias from the defined Vehicle Frame. (For example, a plane being blown in the wind has a large 'crab angle' and the course-over-ground trajectory will not match the direction the IMU is pointing.)

The rotation from the IMU Body frame to the Vehicle frame (RBV) must be set to enable kinematic alignment. In order to simplify this configuration it is strongly suggested that you mount the IMU in parallel to the vehicle frame. When using the default RBV configuration, the X-axis of the SPAN CPT7 should point in the direction of travel.

The kinematic alignment begins when the receiver has a good GNSS position, fine time is solved, the Body to Vehicle frame rotation is known and a GNSS velocity of at least 5 m/s (~ 18 km/h) is observed. During kinematic alignment, keep the vehicle roll at less than 10°.



5 m/s is the default alignment velocity. If a different alignment velocity is required, it can be changed using the **SETALIGNMENTVEL** command. Refer to the [OEM7 Commands and Logs Reference Manual](#) for more information.

While it is possible to lower the minimum speed required for kinematic alignment to take place, the higher the value, the more closely the course-over-ground estimate will match the vehicle heading.

The accuracy of the initial attitude of the system following the kinematic alignment varies and depends on the dynamics of the vehicle. The attitude accuracy will converge to within specifications once some motion is observed by the system. This transition can be observed by monitoring the INS Status field in the INS logs.

Dual Antenna Alignment

SPAN can also use heading information available from a NovAtel Dual Antenna ALIGN solution to rapidly perform an alignment. Refer to *SPAN CPT7 with Dual Antenna* on page 96 for details.

NVM Seeded Alignment

SPAN can use the alignment information from a previous power up to quickly perform an alignment. For information about enabling and using an NVM Seeded Alignment, refer to *INS Seed / Fast INS Initialization* on the next page.

Manual Alignment

If the initial azimuth of the system is known, it can be entered manually using the **SETINITAZIMUTH** command. Refer to the [OEM7 Commands and Logs Reference Manual](#) for more information about this command.



A manual alignment should be used only if the azimuth is accurately known.

4.4.2 INS Seed / Fast INS Initialization

The INS Seed functionality is an alignment method whereby INS alignment information from a previous powerup can be injected into the system at startup to achieve an INS alignment very quickly. This is especially useful for systems that previously required a kinematic alignment.

When INS Seed is enabled, alignment data is automatically saved when appropriate, with no specific action required from the user. During subsequent power ups, the saved solution is compared to the current position of the system, and if valid, the saved solution is used to immediately initialize the inertial filter, making it ready for use.

Error model information is also saved with the seed data. Even if full alignment cannot be achieved, this information will still be used to aid filter convergence, although another method of alignment will be required.

This feature is enabled via the **INSSEED** command. This command setting must be saved to NVM via the **SAVECONFIG** command to be used upon next system boot-up.

Criteria

For the INS seed functionality to be enabled, the **INSSEED ENABLE** command must be sent.

Saving

The following criteria must be met for valid alignment data to be saved into receiver NVM.

- The INS solution status must be converged, as indicated by the INS solution convergence flag in the inertial Extended Solution Status.
- The system velocity is less than 0.2 m/s.

When these conditions are met, the required information is automatically saved to NVM. If these conditions cease to be met, the saved alignment data is automatically discarded. If the alignment data is discarded, error model information is automatically retained as appropriate.

Use at Boot-up

Upon boot, several checks are done to verify that any seed data existing in NVM is appropriate for use. These checks require a GNSS position to be computed, so an NVM seed will never be injected prior to achieving a GNSS position. The following criteria must be met in order to use a seed:

- Seed data from NVM must be valid
- The system must be stationary
- The system must not have moved significantly from the seed position: <10 meters position and 10 degrees in roll and pitch

If a valid error model is present in the seed data from NVM, this will always be used, even if the system is not stationary or exceeded the movement thresholds.



INJECT Option (Advanced Users Only)

There is an advanced option available to skip the second and third validation steps described in the boot-up section above. This can be used if GNSS is not available on power-up or if speed to achieve an alignment is imperative.

This option is for advanced users only. Forcing an injection of an NVM seed without the validation checks can cause an unstable INS solution if the vehicle has moved.

Apart from injecting the seed at startup without validation, this will also remove some requirements typically asserted to allow the filter to converge. This will allow the system to run without GNSS adequately at startup.

Example Usage

Enabling functionality after FRESET:

1. Send the following command.

```
INSSEED ENABLE VALIDATE
```

2. Send the following command.

```
SAVECONFIG
```

Saving valid INS information:

1. Operate the system as normal, until the filter completes convergence.
2. Bring the system to a complete stop before powering off or resetting.

Using valid INS information on start-up:

1. Remain static while initializing.
2. Wait for the system to receive a valid position from GNSS.
3. If valid, alignment data will be injected.

System Indicators

The **INSSEEDSTATUS** log reports the seed injection status for the current power up and information on current seed validity. Refer the [OEM7 Commands and Logs Reference Manual](#) for more information about the **INSSEEDSTATUS** log.

The Extended Solution Status field has bits that indicate the Alignment type that occurred and NVM seed injection status.

Alignment Type: Bits 26-28

These bits indicate how the INS system reached **INS_ALIGNMENT_COMPLETE**. When the INS system aligns using saved INS solution data from NVM, bits 26-28 will be set to 101

NVM Seed Status: Bits 29-31

These bits indicate the current status of the seeding process at start-up, as described in the table below:

Table 7: NVM Seed Indication

Bit 29-31 Values	Hex Value	NVM Seed Type
000	0x00	NVM Seed Inactive
001	0x01	Seed stored in NVM is invalid
010	0x02	NVM Seed failed validation check
011	0x03	NVM Seed is pending validation (awaiting GNSS)
100	0x04	NVM Seed Injected (includes error model data)
101	0x05	NVM Seed data ignored due to a user-commanded filter reset or configuration change
110	0x06	NVM Seed error model data injected

4.4.3 Navigation Mode

Once the alignment routine has successfully completed, SPAN enters navigation mode.

SPAN computes the solution by accumulating velocity and rotation increments from the IMU to generate position, velocity and attitude. SPAN models system errors by using a filter. The GNSS solution, phase observations and automatic zero velocity updates (ZUPTs) provide updates to the filter. Peripheral updates can also be supplied; wheel sensor for displacement updates or heading updates.

Following the alignment, the attitude is coarsely defined, especially in heading. Vehicle dynamics, specifically turns, stops and starts, allow the system to observe the heading error and allows the heading accuracy to converge. The amount of dynamics required for filter convergence vary by the alignment quality, IMU quality, and maneuvers performed. The INS Status field changes to INS_SOLUTION_GOOD once convergence is complete. If the filter decreases in its system accuracy, the INS Status field changes to INS_HIGH_VARIANCE. When the accuracy converges again, the INS status continues as INS_SOLUTION_GOOD.

4.4.4 Data Collection

The INS solution is available in the INS-specific logs with either a standard or short header. Other parameters are available in the logs shown in *Table 8: Solution Parameters* below:

Table 8: Solution Parameters

Parameter	Logs	
Position	INSPOS or INSPOSS INSPVA or INSPVAS	INSPOSEX or INSPVAX
Velocity	INSVEL or INSVELS INSSPD or INSSPDS INSPVA or INSPVAS	INSVELX or INSPVAX
Attitude	INSATT or INSATTS INSPVA or INSPVAS	INSATTX or INSPVAX
Solution Uncertainty	INSSTDEV or INSSTDEVS	



The **INSATTX** log, **INSPOSX** log, **INSPVAX** log and **INSVELX** log contain solution and variance information and are therefore large logs. Use a low logging rate (<20 Hz) only. These logs also contain solution uncertainty in standard deviation format.

Note that the position, velocity and attitude are available together in the **INSPVA** log, **INSPVAS** log and **INSPVAX** log.

The inertial solution is available up to a rate of 200 Hz. Data can be requested at a specific synchronous time interval, asynchronously matching the IMU output rate, or can be triggered by the mark input trigger at rates up to 200 Hz.

The GNSS-only solution is still available through the GNSS-only logs such as RTKPOS and PSRPOS. Refer to the [OEM7 Commands and Logs Reference Manual](#). INS-only data logging and output can be at rates of up to the rate of the IMU data.



The highest rate that you should request GNSS logs (RANGE, BESTPOS, RTKPOS, PSRPOS, and so on) while in INS operation is 5 Hz. If the receiver is not running INS (no IMU is attached), GNSS logs can be requested at rates up to 20 Hz.



Ensure that all windows, other than the Console, are closed in NovAtel Connect and then use the **SAVECONFIG** command to save settings in NVM. Otherwise, unnecessary data logging occurs and may overload your system.



Logging Restriction Important Notice

Logging excessive amounts of high rate data can overload the system. When configuring the output for SPAN, NovAtel recommends that only one high rate (>50 Hz) message be configured for output at a time. It is possible to log more than one message at high rates, but doing so could have negative impacts on the system. Also, if logging 100/200 Hz data, always use the binary format and, if possible, the short header binary format (available on most INS logs).

For optimal performance, log only one high rate output at a time. These logs could be:

- Raw data for post processing
RAWIMUXSB ONNEW
 - RAWIMU logs are not valid with the ONTIME trigger. The raw IMU observations contained in these logs are sequential changes in velocity and rotation. As such, you can only use them for navigation if they are logged at their full rate. Refer to the [OEM7 Commands and Logs Reference Manual](#) for log and command details.
- Real time INS solution
IMURATEPVA ONNEW or IMURATEPVAS ONNEW
 - Other possible INS solution logs available at high rates are: INSPVASB, INSPOSSB, INSVLSB, INSATTSB

Specific logs need to be collected for post-processing. See *Data Collection for Post Processing* on page 87.

To store data from an OEM7 receiver, connect the receiver to a computer running NovAtel Connect or other terminal program capable of recording data.

4.4.5 Body to Vehicle Frame Rotation Calibration Routine

Kinematic alignment requires that the rotational offset between the vehicle and IMU Body frame (RBV) is known. If the angles are simple (that is, a simple rotation about one axis) the values can easily be entered manually through the **SETINSROTATION RBV** command. If the rotational offset is more complex (that is, rotation is about 2 or 3 axis), then the calibration routine provides a more accurate estimation of the values.

The steps for the calibration routine are:

1. Apply power to the SPAN CPT7.
2. Configure the SPAN system including an approximate IMU Body to Vehicle frame (RBV) rotation. See *SPAN Configuration for SPAN CPT7* on page 70.
3. Ensure that an accurate lever arm has been entered into the system.
4. Perform an initial system alignment using one of the methods described in *System Start-Up and Alignment Techniques* on page 76. Ensure the system reaches Solution Good.
5. Enable calibration using the **INSCALIBRATE** command with an optional standard deviation target.

```
INSCALIBRATE RBV NEW [target_stdev]
```

6. To monitor the calibration, log INSCALSTATUS using the ONCHANGED trigger.
7. Start to move the system. Movement of the system is required for the observation of the angular offsets.

Drive a straight course on level ground (remember that most roads have a crown resulting in a constant roll of a few degrees). Avoid driving on a surface with a constant, non-zero, slope to prevent biases in the computed angles. Vehicle speed must be greater than 5 m/s (18 km/hr) for the calibration to complete.

8. When the calibration is complete, either because the accuracy requirement has been met, or the calibration been halted by user command, the calibrated offset value can be viewed in either the **INSCALSTATUS** log or the **INSCONFIG** log.

To save a calibrated rotation for subsequent start ups, issue the **SAVECONFIG** command after calibration is complete. Each time the IMU is re-mounted this calibration should be performed again. See also *Kinematic Alignment* on page 77 for details on kinematic alignment.



After the **INSCALIBRATE RBV ENABLE** command is entered, there are no body-vehicle rotation parameters present and a kinematic alignment is NOT possible. Therefore this command should only be entered after the system has performed a kinematic alignment and has a valid INS solution.



For information about the logs and commands used in this procedure, refer to the [OEM7 Commands and Logs Reference Manual](#).

4.4.6 Multi-Line Body to Vehicle Frame Rotation Calibration Routine

The single pass Body to Vehicle frame offset calibration feature assumes flat ground when estimating the roll offsets between the IMU Body and Vehicle frames, as this component of the rotational offset is difficult to observe through typical ground vehicle motion. In practice this can result in an outstanding roll offset error as high as several degrees. For applications where vehicle roll must be well known, or pass-to-pass accuracy of a highly offset position is especially important, the Multi-Line IMU Body to Vehicle frame offset calibration routine offers higher calibrated accuracy in roll. This is done by running independent calibrations over the same ground path in opposite directions; averaging the results cancels out the effect of any terrain induced roll. A minimum of two iterations are required. Additional iteration pairs can be executed for increased reliability.

Figure 23: Multi-Line IMU Body to Vehicle Calibration

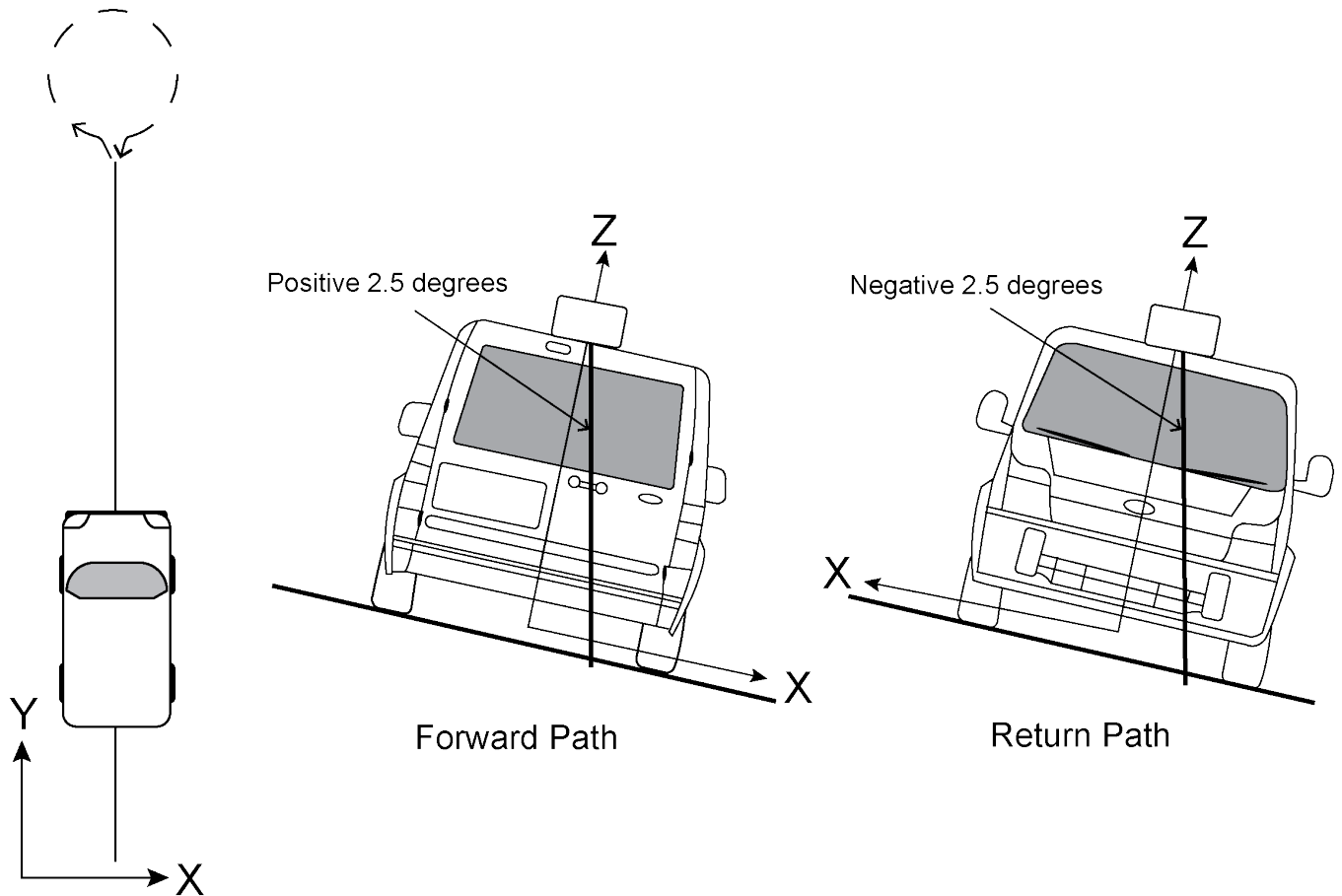

The steps for the calibration routine are:

1. Apply power to the SPAN CPT7.
2. Configure the SPAN system, see *SPAN Configuration for SPAN CPT7* on page 70.
3. Ensure that an accurate lever arm has been entered into the system.
4. Perform an initial system alignment using one of the methods described in *System Start-Up and Alignment Techniques* on page 76. Ensure the system reaches Solution Good.
5. Enable a new calibration using the **INSCALIBRATE** command, with the optional standard deviation target omitted:

```
INSCALIBRATE RBV NEW
```

6. Start to move the vehicle. Drive a straight course, at a vehicle speed greater than 5 m/s (18 km/hr). A distance of approximately 250 meters is recommended.

To monitor the calibration, log **INSCALSTATUS** using the ONCHANGED trigger.

7. When the end of the available distance is reached, stop the vehicle. Halt the ongoing calibration by sending the **INSCALIBRATE** command again:

```
INSCALIBRATE RBV STOP
```

8. At this point **INSCALSTATUS** will report a source status of CALIBRATED. Turn the vehicle around and come to a stop on the finishing point of the previous line.
9. Initiate the second pass of the calibration by issuing the **INSCALIBRATE** command with the **ADD**

parameter:

```
INSCALIBRATE RBV ADD
```

10. Drive the vehicle back along the original course, until you reach the starting point for the first pass. Stop the vehicle, and re-issue the **INSCALIBRATE** command, with the **STOP** parameter. **INSCALSTATUS** will again indicate a source status of CALIBRATED.

At this point the multi-line calibration can be considered complete, but more iterations can be repeated until the desired accuracy level is reached.

11. When the calibration is complete, the calibrated offset value can be viewed in either the **INSCALSTATUS** log or the **INSCONFIG** log.

To save a calibrated rotation for subsequent start ups, issue the **SAVECONFIG** command after calibration is complete. Each time the IMU is re-mounted this calibration should be performed again.



After the **INSCALIBRATE RBV ENABLE** command is entered, there are no body-vehicle rotation parameters present and a kinematic alignment is NOT possible. Therefore this command should only be entered after the system has performed a kinematic alignment and has a valid INS solution.



For information about the logs and commands used in this procedure, refer to the [OEM7 Commands and Logs Reference Manual](#).

4.5 Synchronizing External Equipment

A SPAN system allows you to synchronize with external equipment.

All SPAN receivers accept input pulses (events). Each event signal can be configured for positive or negative polarity. Time, or a solution (position, velocity, attitude), can be generated and output with each input pulse.

4.5.1 Configuring an Input Strobe

SPAN systems have several input strobes. The input strobes apply an accurate GNSS time to the rising, or falling, edge of an input pulse called an event. For each event, an accurate position, velocity or attitude solution is also available. Each input strobe is usually associated with a separate device, therefore different solution output lever arm offsets can be applied to each strobe.

Each input strobe can be configured using the **EVENTINCONTROL** command for the following parameters:

Polarity:

When polarity is set to positive, events trigger on the rising edge. When polarity is set to negative, events trigger on the falling edge.

Time Bias (t_bias):

A constant time bias in nanoseconds can be applied to each event pulse. Typically this is used to account for a transmission delay.

Time Guard (t_guard):

The time guard specifies the minimum number of milliseconds between pulses. This is used to coarsely filter the input pulses.

The time of the input pulses is available from the **MARKTIME**, **MARK2TIME**, **MARK3TIME** and **MARK4TIME** log. The solution synchronous with the event pulses is available from the **MARK1PVA**, **MARK2PVA**, **MARK3PVA** and **MARK4PVA** log. The logs required for input strobes are:

LOG MARK1TIMEB ONNEW

Output time for every pulse received.

LOG MARK1PVAB ONNEW

Output time, position, velocity and attitude for every pulse received at the location specified by the **SETINSTRANSLATION** command and **SETINSROTATION** command.

The above example is for the MARK1 event input. The minimum detectable pulse duration must be greater than or equal to 1 microsecond.



The input signal levels are 3.3 V to 0 V. Signal voltages outside these bounds damage the receiver.



For information about the logs and commands used in this procedure, refer to the [OEM7 Commands and Logs Reference Manual](#).

4.6 Adding Timed Sensor Triggers

Use the EVENT IN and EVENT OUT connections to attach up to two sensor devices to a SPAN CPT7 and then trigger the sensors based upon GPS time.

In this context a 'sensor' is any external device. The 'sensor' reference in the receiver is an object consisting of an Event_In and Event_Out pair of system strobes all linked by a sensor identifier.

You can send multiple trigger events marked with a user-specified ID and a GPS time to trigger the sensor. At the requested trigger time, the receiver outputs a user-specified LVCMOS level pulse to the sensor and waits for a response pulse to indicate a sensor measurement (i.e. camera exposure). When this response is received, the SPAN system outputs a log with the inertial position/velocity/attitude and the ID of the event.

4.6.1 Configuring the Hardware

A sensor's trigger input is connected to a valid Event_Out and the sensor's response output is connected to a valid Event_In. Three sensor slots are available for use, but may be limited to less depending on the hardware platform used.

Table 9: Valid Event Inputs and Outputs for Timed Sensor Triggers

Valid Event Outputs	Valid Event Inputs
MARK1	MARK1
MARK2	MARK2

4.6.2 Configuring the Software

Sensor objects are defined by using the **SETUPSENSOR** command. This command allows the Event_In and Event_Out lines to be specified as well as some parameters for the outgoing and incoming signals.



After configuring a sensor using the **SETUPSENSOR** command, any other commands that affect the selected event lines will disturb this functionality. For example, if MARK2 Out is selected for a sensor, but later the **EVENTOUTCONTROL** command is sent, the **EVENTOUTCONTROL** command will reconfigure the properties of the MARK2 line.

4.6.3 Using Timed Event Pulses

When sensors have been connected and configured, use the **TIMEEVENTPULSE** command to queue events on the system. **TIMEEVENTPULSE** specifies the sensors that are affected, the GPS time for the desired event (in weeks and seconds), and an event ID. You can queue 10 unprocessed events at a time. Any time input specified via this command must occur at least 1 second after the command is entered.

The timing accuracy of the **TIMEEVENTPULSE** output is 2 milliseconds.

4.6.4 Recording Incoming Sensor Events

After a **TIMEEVENTPULSE** is sent, the system can be configured to accept an incoming pulse from the sensor in order to produce a time and ID tagged inertial solution associated to that event. This is optional and useful if a sensor provides a measurement TOV pulse. The produced log is a TAGGEDxMARKPVA where the 'x' is the Event_In line associated with that sensor (via the **SETUPSENSOR** command).

For example, if the **SETUPSENSOR** command specifies SENSOR1 to use MARK1 in as the input event then a TAGGEDMARK1PVA log will be produced when any pulses on that line are observed. In this case the TAGGEDMARK1PVA log should be requested ONNEW to capture the data.

4.7 Azimuth Sources on a SPAN System

The SPAN system use three different methods to calculate the azimuth.

- Course Over Ground
- Inertial Azimuth
- ALIGN Azimuth

4.7.1 Course Over Ground

The course over ground azimuth is determined using the position delta between two position solutions computed by the OEM7 receiver. This is the simplest way to compute an azimuth and is done using either the GNSS solution or the INS solution. This method does not work when the vehicle is stationary as any position difference is due to position error and the computed azimuth is meaningless.

Course over ground azimuth is of greatest advantage in aerial or marine environments where the actual direction of travel may not match the forward axis of the aircraft/boat due to winds or currents. This effect is known as the crab angle. Course over ground azimuth is a great way to compute the offset if another means of computing the vehicle azimuth is available.

Course over ground azimuths are available in several different velocity logs. See *Table 10: Logs with Azimuth Data* on the next page.

4.7.2 Inertial Azimuth

The inertial azimuth computed by the SPAN inertial navigation filter. It uses the sensors in the IMU to compute the azimuth of the IMU (this can be rotated to another reference if desired). For more information, see the **SETINSROTATION** command in the [OEM7 Commands and Logs Reference Manual](#).

This azimuth is the one provided in the majority of the INS logs available to a SPAN user. See *Table 10: Logs with Azimuth Data* below.

4.7.3 ALIGN Azimuth

On SPAN systems with dual antennas, an azimuth is available from the dual antenna baseline. This is the same azimuth that is used as an update to the SPAN solution. It is noisier than the inertial azimuth and is available at a much lower rate, but will have a stable mean. This azimuth is computed from the master antenna to the rover antenna based on how the antennas are oriented on the vehicle.

There is a specific subset of logs that output this azimuth. See *Table 10: Logs with Azimuth Data* below.

Table 10: Logs with Azimuth Data

Log	Log Format	Azimuth Source
BESTGNSSVEL	NovAtel	Course Over Ground From the best GNSS only solution
BESTVEL	NovAtel	Course Over Ground From the best system solution which could be either GNSS or INS
GPHDT	NMEA	ALIGN
GPVTG	NMEA	Course Over Ground From the best system solution which could be either GNSS or INS
HEADING2	NovAtel	ALIGN
INSATT / INSATTS / INSATTX	NovAtel	Inertial
INSPVA / INSPVAS / INSPVAX	NovAtel	Inertial
INSSPD	NovAtel	Course Over Ground Computed using the INS solution only
PASHR	NMEA	Inertial

4.8 Data Collection for Post Processing

Some operations, such as aerial measurement systems, do not require real-time information from SPAN. These operations are able to generate the position, velocity or attitude solution post-mission in order to generate a more robust and accurate solution than is possible in real-time.

In order to generate a solution in post-processing, data must be simultaneously collected at a base station and each rover. The following logs must be collected in order to successfully post process data.

From a base:

- RANGECMPB ONTIME 1
- RAWEPHEMB ONCHANGED

- GLOEPHEMERISB ONCHANGED (if using GLONASS)
- GALFNAVEPHEMERIS ONCHANGED (if using Galileo)
- GALINAVEPHEMERIS ONCHANGED (if using Galileo)
- BDSEPHEMERIS ONCHANGED (if using BeiDou)

From a rover:

- RANGECMPB ONTIME 1
- RAWEPHEMB ONCHANGED
- GLOEPHEMERISB ONCHANGED (if using GLONASS)
- GALFNAVEPHEMERIS ONCHANGED (if using Galileo)
- GALINAVEPHEMERIS ONCHANGED (if using Galileo)
- BDSEPHEMERIS ONCHANGED (if using BeiDou)
- INSCONFIGB ONCHANGED
- RAWIMUSXB ONNEW
- HEADING2B ONNEW (if using ALIGN dual antenna solution)

Post processing is performed through the Waypoint Inertial Explorer[®] software package available from the NovAtel Waypoint Products Group. Visit our Web site at www.novatel.com for details.



The highest rate that you should request GNSS logs (RANGE, BESTPOS, RTKPOS, PSRPOS, and so on) while in INS operation is 5 Hz. If the receiver is not running INS (no IMU is attached), GNSS logs can be requested at rates up to 20 Hz.

4.9 Variable Lever Arm

The variable lever arm concept arose to support applications in which the IMU is no longer rigidly fixed to the vehicle, but rather on a gimballed mount. This creates an issue where the input lever arm offsets to the GNSS antenna are no longer correct, because the IMU can rotate on its mount, while the antenna remains fixed.

The use of the variable lever arm functionality requires that the device to which the IMU is attached be able to send its gimbal rotation angles back to SPAN. These angles are used to recalculate the lever arm at the rate that they are received. SPAN will also be able to output a gimballed solution at the rate the gimbal angles are received.

4.9.1 Reference Frame Description

There are several frames of reference involved when dealing with a gimballed mount. The frames are all very similar, but can be quite confusing due to small differences. Below are all frames applicable to the implementation of the variable lever arm:

Frame	Description	Notation
IMU Body frame	The physical IMU axes	(b)
Vehicle frame	Default reference frame for attitude output in SPAN logs	(v)
Mount body frame	The physical axes of the gimballed mount	(m)

Frame	Description	Notation
Gimbal body frame	The physical axes of the gimbal plane. This frame matches the mount body frame when gimbal angles are zero and rotates relative to the mount body frame when the gimbal is active.	(g)
User Output Frame	An arbitrary frame, used to define the desired reference for attitude output, typically matching a gimbal mounted sensor	(ou)
Mark Output Frame	An arbitrary frame, used to define the desired reference for attitude output for the MARKxPVA logs, typically matching a gimbal mounted sensor	(om)

Figure 24: Sample Configuration on the next page and *Figure 25: Operating Gimbal* on page 91 illustrate a basic scenario for the information in the table above. *Figure 24: Sample Configuration* on the next page shows a possible configuration for the mount body frame, IMU body frame and a user output frame, with the gimbal in a locked position. The extra rotation commands required to configure Variable Lever Arm for this setup are:

```
SETINSROTATION RBM 180 0 0
SETINSROTATION USER 0 0 90
SETINSROTATION RBV 0 0 -90
```

Figure 25: Operating Gimbal on page 91 shows the gimbal in operation; the gimbal platform has moved relative to the mount body frame. The gimbal frame and IMU Body frame move together, as does the user output (or mark output) frame.

Figure 24: Sample Configuration

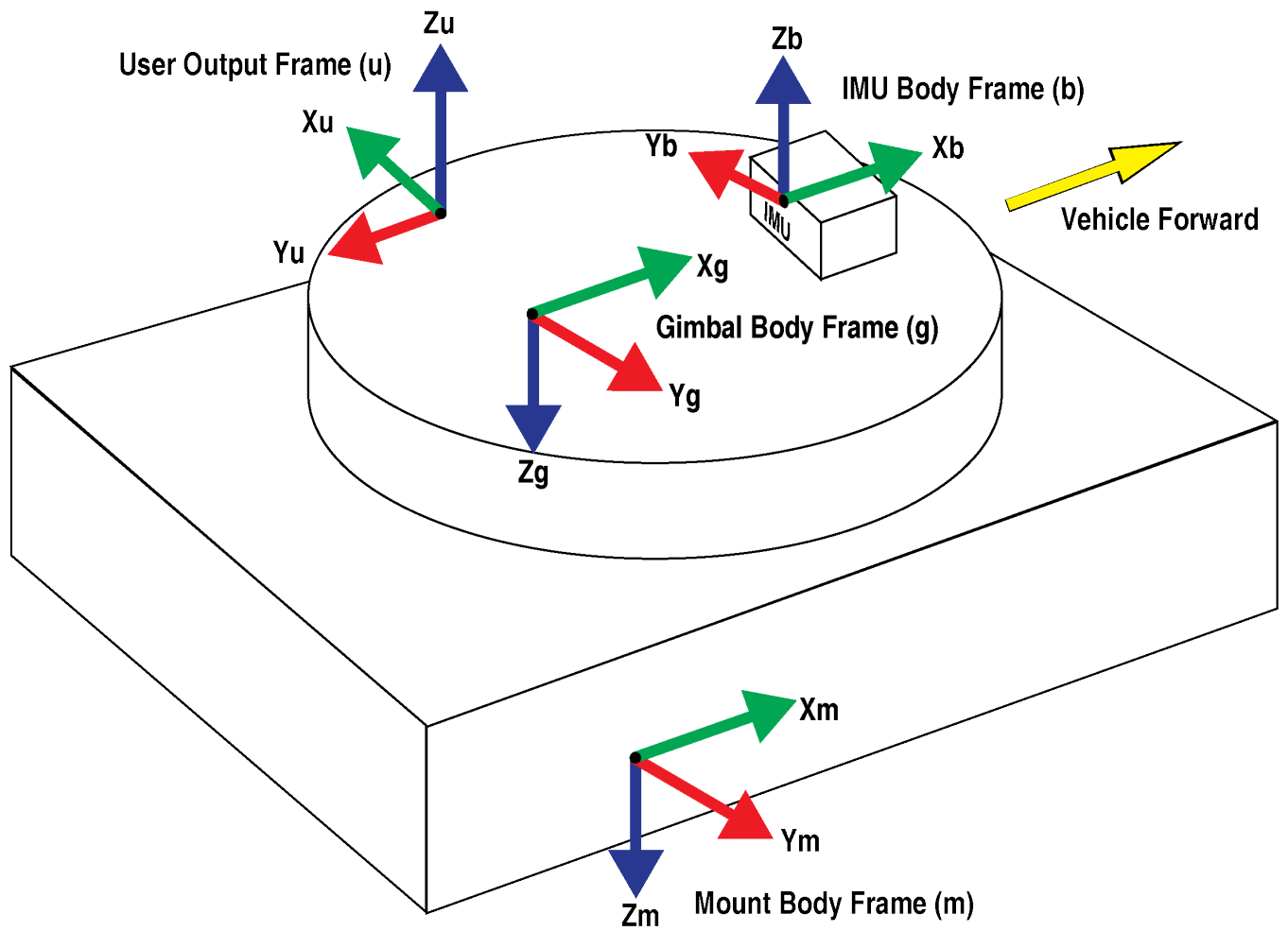
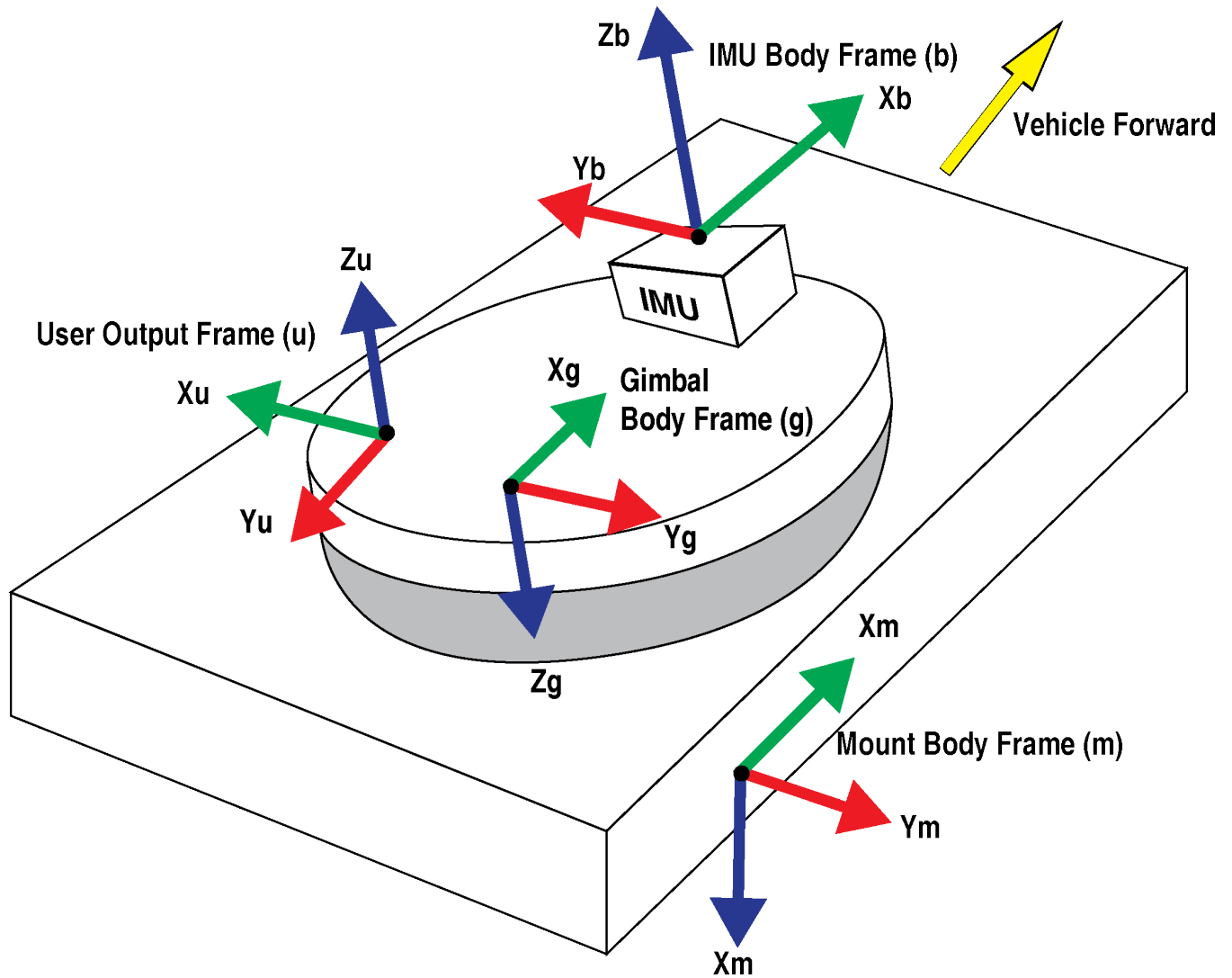

Figure 25: Operating Gimbal



4.9.2 How to Use Variable Lever Arm

The variable lever arm functionality is simple to use in a SPAN system. It requires the input of gimbal angles from the camera mount or platform that the IMU is mounted on. After that is provided, the system will automatically compute the variable lever arm and produce several messages for output.

Ensuring a proper variable lever arm is important for SPAN performance.

Basic I/O

The variable lever arm functionality is based on the input of the **INPUTGIMBALANGLE** command. This command specifies the right-handed rotation angles from the **mount body frame (m)** to the **gimbal body frame (g)**, with the order of rotations Z-X-Y. Entering this command will automatically cause the system to rotate the static lever arm into the latest gimballed frame. The update rate of the variable lever arm depends on the rate of the gimbal commands which can be entered at 1 to 50 Hz. If an **INPUTGIMBALANGLE** command is not received for over 1 second then the system will return to using the static lever arm.

In addition to using the variable lever arm internally, the following information is available to the user.

Table 11: Logs used with Variable Lever Arm

Log	Description
VARIABLELEVERARM	<p>This log displays the calculated variable lever arm.</p> <p>The VARIABLELEVERARM log is output in IMU Body frame.</p> <div style="border: 1px solid black; padding: 5px; margin-top: 10px;">  The VARIABLELEVERARM log will not be published or used internally unless a SETINSROTATION RBM command is sent. </div>
GIMBALLEDPVA	<p>This log has the same format as the INSPVA log, but contains the attitude rotated back to the null gimbal position. When the gimbal mount is in its zero locked position, the GIMBALLEDPVA attitude will match the attitude given in the INSPVA log. If the translational offset to the gimbal center of rotation has been provided, the position and velocity output are offset to this position. Otherwise, the position and velocity values are given at the IMU center of navigation.</p>
INSPVA, INSPVAS, INSPVAX	<p>The INSPVA log is synchronous so does not depend on the entry of the INPUTGIMBALANGLE command. However when the gimbal angles are non-zero, the INSPVA log no longer represents the orientation of the gimbal mount / vehicle, but rather the current orientation of the unlocked gimbal platform. If the orientation of the vehicle is important, use the GIMBALLEDPVA log.</p>

Rotations and Translations

For the information provided by the system to be meaningful, the following offsets have to be set correctly. By default the system assumes that the IMU Body frame, gimbal mount and Mount Body frame are coincident. If this is not the case then additional commands are necessary to relate all of the different frames together using the commands below. If attitude output is desired relative to an external camera, this can also be configured using these commands.



When entering the SETINSROTATION commands described in the following table, the gimbal mount should be locked (INPUTGIMBALANGLE rotations are zero).

Table 12: Commands used with Variable Lever Arm

Command	Purpose
SETINSROTATION RBV	<p>This command provides the orientation of the IMU Body frame while the gimbal frame is in the locked null position. This is required information before the SPAN system can complete an inertial alignment. The SETINSROTATION RBV command relates the IMU Body frame (b) to the Vehicle frame (v).</p> <p>Once an RBV rotation has been provided, default attitude output will be referenced to the Vehicle frame.</p>
SETINSROTATION RBM	<p>This command relates the IMU Body frame (b) to the Mount Body frame (m). This information is required for interpreting the rotation angles from the VARIABLELEVERARM log correctly.</p>

Command	Purpose
SETINSROTATION USER	By default, attitude information output by SPAN is for the vehicle frame. If attitude output is required to be referenced to another frame (typically the axes of a gimbal-mounted sensor), the USER offset can be used to rotate the attitude output in general SPAN logs to this frame.
SETINSROTATION MARKx	Similar to the user rotation, this rotation can be used to change the attitude output reference frame for the MARKxPVA logs.
SETINSTRANSALATION GIMBAL	This command provides the offset from the IMU center of navigation to the gimbal center of navigation. This is an optional translation used by Inertial Explorer for post-processing.

4.10 Relative INS

NovAtel's Relative INS technology generates a position, velocity and full attitude vector between two SPAN systems. One is the Master receiver and the other is the Rover receiver. Once configured, the Master receiver begins transmitting corrections to the Rover receiver. Relative information is created and the system begins filling the **RELINSPVA** log and **SYNCRELINSPVA** log on the Rover receiver. The **RELINSPVA** log is then transmitted back to the Master receiver for output.

The data link required must be able to support [864bits+108bits x #obs tracked per second]. The **RELINSPVA** log is requested ONNEW (available from 1Hz-20Hz depending on the setup of the **RELINSAUTOMATION** command) while the **SYNCRELINSPVA** log can be requested ONTIME at up to 200Hz (at the rover only). Position and velocity solutions are differenced in the ECEF frame and then rotated into the local level. The Relative offset vector that is output is dependent on Master/Rover's precise RTK vector and their eccentric offset vectors (optional offset provided using the **USER** parameter in the **SETINSTRANSALATION** command), shown in *Figure 26: Relative INS Example* on the next page.

Figure 26: Relative INS Example

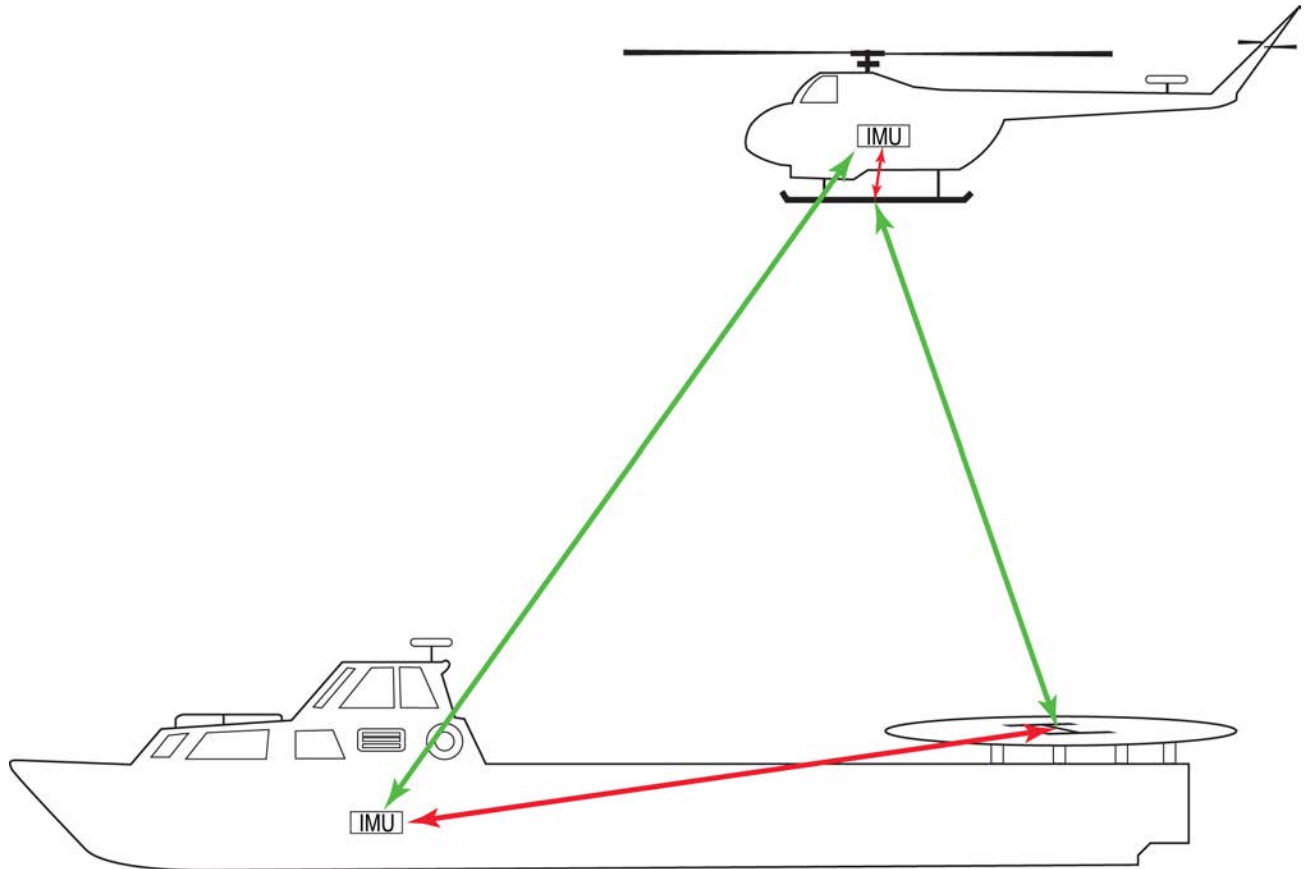

An important command that can be used with Relative INS to manually change the maximum amount of time to use RTK data is the **RTKTIMEOUT** command. This command is used to set the maximum age of RTK data to use when operating as a rover station. RTK data received that is older than the specified time is ignored. The default is 60 seconds, however when using Relative INS, it is suggested this be set to 5 seconds by sending the command **RTKTIMEOUT 5**.



For information about the **RTKTIMEOUT** command, refer to the [OEM7 Commands and Logs Reference Manual](#).

4.10.1 Configure Relative INS

To configure the receivers to begin computing the relative information:

1. Setup a link between the receivers that will be used to transfer data (for example, radios).
2. Enable the transfer of relative corrections between receivers using one of the methods below.
 - Send the **RELINSAUTOMATION** command only at the Rover receiver
 - Send the **RELINSCONFIG** command at both the Master and Rover receiver



To configure Relative INS using the **RELINSAUTOMATION** command, the master and rover receivers must be communicating using a COM port. If the master and rover are communicating via an ICOM port, the **RELINSCONFIG** command must be used.



The Model option must be present on both the rover and master for the Relative INS feature to be enabled.



The master and rover receiver must be using the same datum.

Chapter 5 SPAN CPT7 with Dual Antenna

NovAtel's ALIGN[®] heading technology generates a heading solution using the position information from the primary and secondary GNSS antenna. The SPAN CPT7 can provide an ALIGN[®] solution without an additional receiver.

With SPAN, the ALIGN GNSS baseline can be used to assist the initial alignment of the SPAN solution. In addition, the ALIGN baseline solution will aid the heading solution from the receiver if the heading drifts due to slow or constant dynamics.

ALIGN is capable of a 10 Hz heading output rate when integrated with the SPAN CPT7.



For optimal SPAN performance when using Dual Antenna with SPAN an ALIGN offset calibration is required for each unique installation. This calibration refines the IMU to antenna baseline angular offset from the initial estimate derived from the input lever arms. Refer to **INSCALIBRATE** command for details.

5.1 Configuring ALIGN with SPAN

To enable the dual-antenna ALIGN solution to aid the INS alignment and provide heading updates, the offset between the antennas and the SPAN CPT7 must be known. This is achieved by entering lever arms to both antennas, using the **SETINSTRANSULATION** command.

To configure SPAN with ALIGN Aiding:

1. Enter the lever arm from the SPAN CPT7 to the primary antenna (antenna connected to the RF1 connector).

Abbreviated ASCII example:

```
SETINSTRANSULATION ANT1 0.54 0.32 1.20 0.03 0.03 0.05
```

2. Enter the lever arm from the SPAN CPT7 to the secondary antenna (antenna connected to the RF2 connector).

Abbreviated ASCII example:

```
SETINSTRANSULATION ANT2 0.54 2.32 1.20 0.03 0.03 0.05
```

Alternately, the angular offset between the dual-antenna baseline (from primary GNSS antenna to secondary GNSS antenna) and the IMU frame forward axis is entered directly via the **ALIGN** parameter of the **SETINSROTATION** command.



We recommend entering the lever arms rather than entering the angular offset as this is easier to measure and will lead to better overall accuracy.

Refer to the [OEM7 Commands and Logs Reference Manual](#) for the syntax of the above commands.

As with all ALIGN-capable products, the GNSS baseline solution is available from the **GPHDT** log and **HEADING2** log. For INS heading, use the **INSATT** log or **INSPVA** log.

The SPAN system can be configured for different alignment routines depending on the motion conditions experienced during the alignment period. For example, in marine applications, the dynamics required for a kinematic alignment cannot be guaranteed, so a different alignment routine is required.

The different alignment routines are described in *Configuring SPAN with ALIGN* on the next page.

5.1.1 Configuring SPAN with ALIGN

The SPAN receiver can be configured for different alignment routines depending on the motion conditions experienced during the alignment period. For example, in marine applications, the dynamics required for either a kinematic alignment cannot be guaranteed, so a different alignment routine will be required.



Before the ALIGN heading can be computed and used by SPAN, both GNSS antennas must have a clear view of the sky.



For optimal SPAN performance when using Dual Antenna with SPAN an ALIGN offset calibration is required for each unique installation. This calibration refines the IMU to antenna baseline angular offset from the initial estimate derived from the input lever arms. Refer to **INSCALIBRATE** command for details.

The different alignment routines are described in the following sections:

5.1.2 Alignment on a Moving Vessel - Aided Transfer Alignment

This alignment routine is the preferred dual antenna alignment method. It is used if the alignment mode is set to AIDED_TRANSFER using the **ALIGNMENTMODE** command, and can be used if the alignment mode is set to AUTOMATIC.

If your vehicle is not stationary during the alignment, such as may be the case on a ship, use the Aided Transfer Alignment routine. This alignment method uses the ALIGN baseline solution to perform an instantaneous alignment of the vehicle attitude.

The alignment happens instantaneously after the receiver establishes communication with the IMU and computes a verified, fixed integer, ALIGN solution. The INS status changes to INS_ALIGNMENT_COMPLETE or INS_SOLUTION_GOOD, depending on the variances of the ALIGN solution, and the measured lever arm/external heading offset.

To guarantee the use of this alignment mode, the **ALIGNMENTMODE** command must be sent to the receiver:

```
ALIGNMENTMODE AIDED_TRANSFER
```

5.1.3 Alignment on a Stationary Vehicle - Aided Static Alignment

An alternative to the aided transfer alignment, the ALIGN heading can be used as a seed for a coarse static alignment. In this mode, the standard coarse alignment routine runs given the initial azimuth value. As with the transfer alignment, the first verified fixed RTK solution is used to provide the alignment seed after which the coarse alignment (INS_ALIGNING) begins. After the coarse alignment is complete, the INS status changes to INS_ALIGNMENT_COMPLETE. After the attitude accuracy has converged, the INS status changes to INS_SOLUTION_GOOD. This alignment mode is useful if the initial vehicle roll is more than 20 degrees.

To use this alignment mode, the **ALIGNMENTMODE** command must be sent to the receiver.

```
ALIGNMENTMODE AIDED_STATIC
```

5.1.4 Unaided Alignment

The unaided alignment sets the SPAN system to use only single antenna alignment options (kinematic or manual alignment).

To use this alignment mode, the **ALIGNMENTMODE** command must be sent to the receiver.

```
ALIGNMENTMODE UNAIDED
```

5.1.5 Automatic Alignment Mode - Automatic Alignment (default)

Automatic Alignment Mode Selection is the default setting for a SPAN receiver. This mode is designed to allow alignment of the system as quickly as possible, using either an aided transfer alignment (*Alignment on a Moving Vessel - Aided Transfer Alignment* on the previous page); a kinematic alignment (*Kinematic Alignment* on page 77); or a manual alignment (*Manual Alignment* on page 78).

The first available technique will be used, regardless of its relative quality. If you wish to guarantee a specific technique is used, or use an aided static alignment, you must select the desired alignment mode manually. No additional configuration is required to use this alignment routine.

5.2 SPAN ALIGN Attitude Updates

The INS heading updates are used to help constrain the azimuth drift of the INS solution whenever possible. This is of the greatest value with lower-quality IMUs and in environments with low dynamics where the attitude error is less observable. Slow moving marine or train applications are good examples of the intended use. By providing an external heading source, the solution drift can be constrained in these environments.

You can monitor the heading update status as outlined in the **INSUPDATESTATUS** log in the [OEM7 Commands and Logs Reference Manual](#).

Chapter 6 Ethernet Configuration

This chapter describes how to configure the Ethernet port on an OEM7 receiver. It provides the step-by-step process for connecting to the OEM7 receiver through the Ethernet interface, setting up a base/rover configuration through Ethernet connectivity and utilizing the NTRIP interface. The Ethernet port connections for a computer connected to the receiver are also described for Windows 7 operating systems.



In this chapter, references to OEM7 receivers includes the SPAN CPT7.



The **SAVEETHERNETDATA** command can be issued to retain the Ethernet configuration settings after a **RESET/FRESET** command. The **ETHCONFIG** command and **IPCONFIG** command must be issued prior to using **SAVEETHERNETDATA** command. Refer to the [OEM7 Commands and Logs Reference Manual](#).

6.1 Required Hardware

The following hardware is required to set up an Ethernet interface to an OEM7 receiver:

- a user supplied computer with an available Ethernet, serial or USB port
- a GNSS antenna
- an Ethernet capable OEM7 receiver
- an RS-232 null modem cable or USB cable
- one or two CAT5 Ethernet cables
- a user supplied Ethernet network, hub or wired router (optional)
- a coaxial antenna cable (50 Ω)

6.2 Static IP Address Configuration

For a static IP address configuration, unique IP addresses are assigned to both the OEM7 receiver and the computer. TCP/IP is used for the connection in this simple network. This configuration can also be used in a bench test environment to confirm Ethernet functionality.

For connections when an OEM7 receiver uses a static IP address configuration, refer to *Figure 27: Cross-Over Ethernet Cable Configuration—OEM7 Receiver* on the next page.

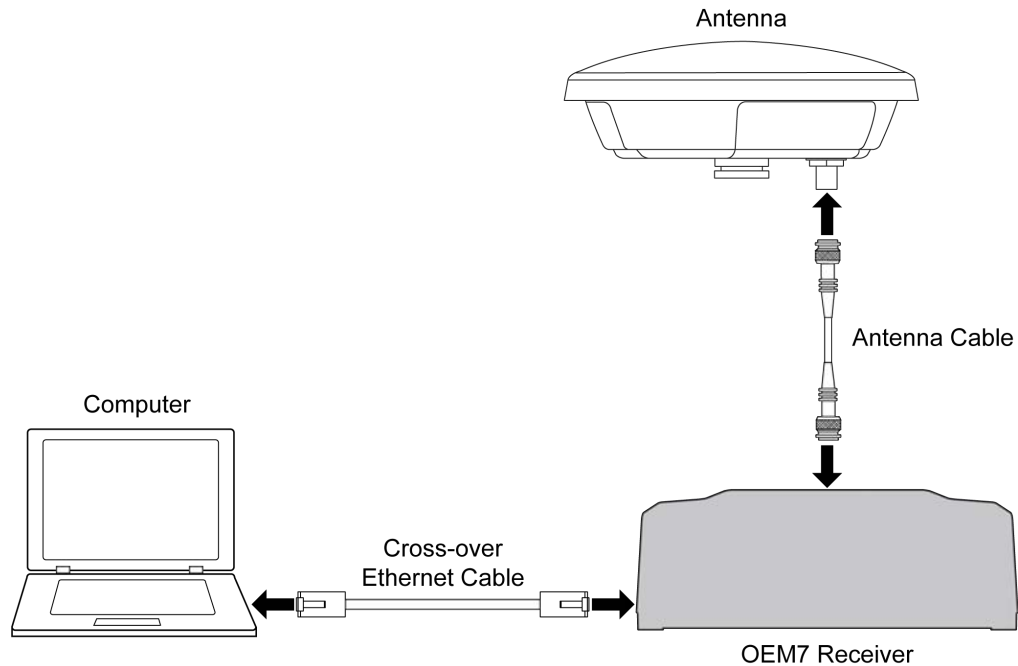
Figure 27: Cross-Over Ethernet Cable Configuration—OEM7 Receiver

6.2.1 Static IP Address Configuration—Receiver

Follow these steps to set up a static IP address on the OEM7 receiver:

1. Connect a computer to the OEM7 receiver using a null modem serial cable or USB cable.
2. Establish a connection to the receiver using either NovAtel Connect or another terminal program. This connection is used to send the commands in this procedure to the receiver.



For information about establishing a connection using NovAtel Connect, refer to the Help within NovAtel Connect.



NovAtel Connect version 2.0 or greater is required for OEM7 receivers. Download the latest NovAtel Connect software and documentation from www.novatel.com/novatel-connect.

3. Enable the Ethernet port on the receiver by entering:

```
ETHCONFIG ETHA AUTO AUTO AUTO AUTO
```

4. Assign the TCP/IP port number used for the connection by entering:

```
ICOMCONFIG ICOM1 TCP :2000
```

5. Assign the receiver IP address, subnet mask and default gateway by entering:

```
IPCONFIG ETHA STATIC 192.168.74.10 255.255.255.0 192.168.74.1
```



The command assigns the following values to the OEM7 receiver:

```
IP address = 192.168.74.10
Subnet mask = 255.255.255.0
Gateway = 192.168.74.1
```

These settings are examples only. The settings appropriate to your system may be different.

6. Save the new Ethernet settings by entering:

```
SAVEETHERNETDATA
```

7. Log the **IPCONFIG** command and confirm the TCP/IP configuration by entering:

```
LOG IPCONFIG ONCE
```

8. Configure your computer with a static IP address.
Refer to *Static IP Address Configuration—Windows 7* below.

6.2.2 Static IP Address Configuration—Windows 7

Follow these steps to set up a static IP address on a computer:

1. Click **Start | Control Panel**.
2. Click **Network and Sharing Center**.
3. Click the **Local Area Connection** link.
The Local Area Connection Status window appears.
4. Click the **Properties** button.
The Local Area Connection Properties window appears.
5. Select **Internet Protocol Version 4 (TCP/IPv4)** and then click the **Properties** button.
The Internet Protocol Version 4 (TCP/IPv4) Properties window appears.
6. Click the **Use the Following IP Address** radio button, then enter the IP address, Subnet mask and Default gateway for the Ethernet port on the computer.



Ensure the Ethernet settings used for the computer are compatible with the Ethernet settings on the OEM7 receiver.

For example, the following settings are compatible with the OEM7 receiver settings used in *Static IP Address Configuration—Receiver* on the previous page:

```
IP address = 192.168.74.11
Subnet mask = 255.255.255.0
Gateway = 192.168.74.1
```

7. Click the **OK** button.
The Local Area Connection Properties window appears.
8. Click the **Close** button.
The Local Area Connection Status window appears.
9. Click the **Close** button.
10. Proceed to *Confirming Ethernet Setup* on the next page.

6.2.3 Confirming Ethernet Setup

1. Connect the computer to the OEM7 receiver using an Ethernet cross-over cable.
See *Figure 27: Cross-Over Ethernet Cable Configuration—OEM7 Receiver* on page 100.
2. Connect to the receiver using NovAtel Connect or any third party terminal program that supports TCP/IP connections. Use the static IP address and port number assigned to the OEM7 receiver in *Static IP Address Configuration—Receiver* on page 100.



NovAtel Connect version 2.0 or greater is required for OEM7 receivers. Download the latest NovAtel Connect software and documentation from www.novatel.com/novatel-connect.

6.3 Dynamic IP Address Configuration

Figure 28: Dynamic IP Address Configuration through a DHCP Server—OEM7 Receiver below shows the connections when an OEM7 receiver uses a dynamic IP address configuration.

Figure 28: Dynamic IP Address Configuration through a DHCP Server—OEM7 Receiver

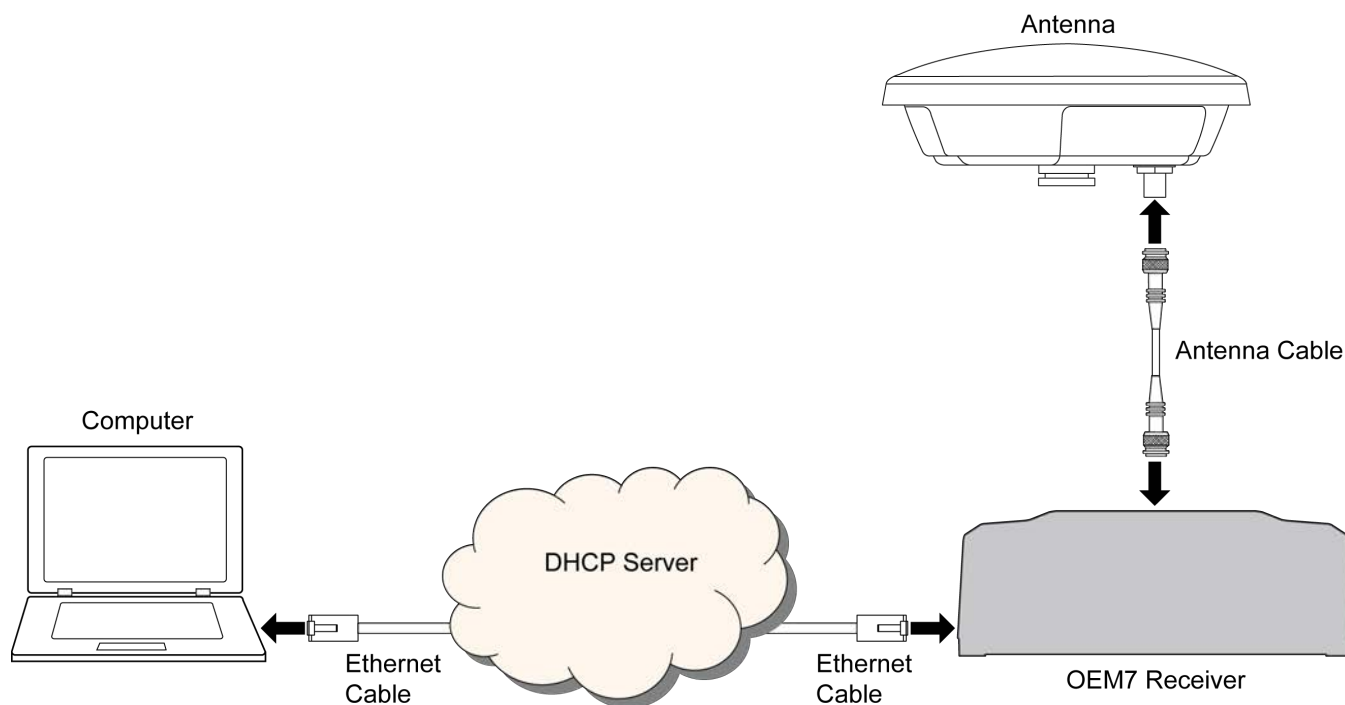

To set up a dynamic IP address configuration, follow these steps:

1. Connect a computer to the OEM7 receiver using a null modem serial cable or USB cable (model dependent).
2. Establish a connection to the receiver using either NovAtel Connect or another terminal program. This connection is used to send the commands in this procedure to the receiver.



For information about establishing a connection using NovAtel Connect, refer to the Help within NovAtel Connect.



NovAtel Connect version 2.0 or greater is required for OEM7 receivers. Download the latest NovAtel Connect software and documentation from www.novatel.com/novatel-connect.

3. Enable the Ethernet port by entering:

```
ETHCONFIG ETHA AUTO AUTO AUTO AUTO
```

4. Obtain the IP address assigned to the OEM7 receiver by the DHCP server.

```
LOG IPSTATUS ONCE
```



Make a note of the IP address returned with this log.

5. Assign the TCP/IP port number by entering:

```
ICOMCONFIG ICOM1 TCP :2000
```

6. Confirm the port number assigned to ICOM1 by entering:

```
LOG ICOMCONFIG ONCE
```

6.4 Base/Rover Configuration through Ethernet Connectivity

You can use an Ethernet connection to provide communication between a base and rover receiver.

Figure 29: Base/Rover Ethernet Setup—OEM7 Receiver on the next page shows the connections when a base and rover OEM7 receiver are connected using Ethernet.

Figure 29: Base/Rover Ethernet Setup—OEM7 Receiver

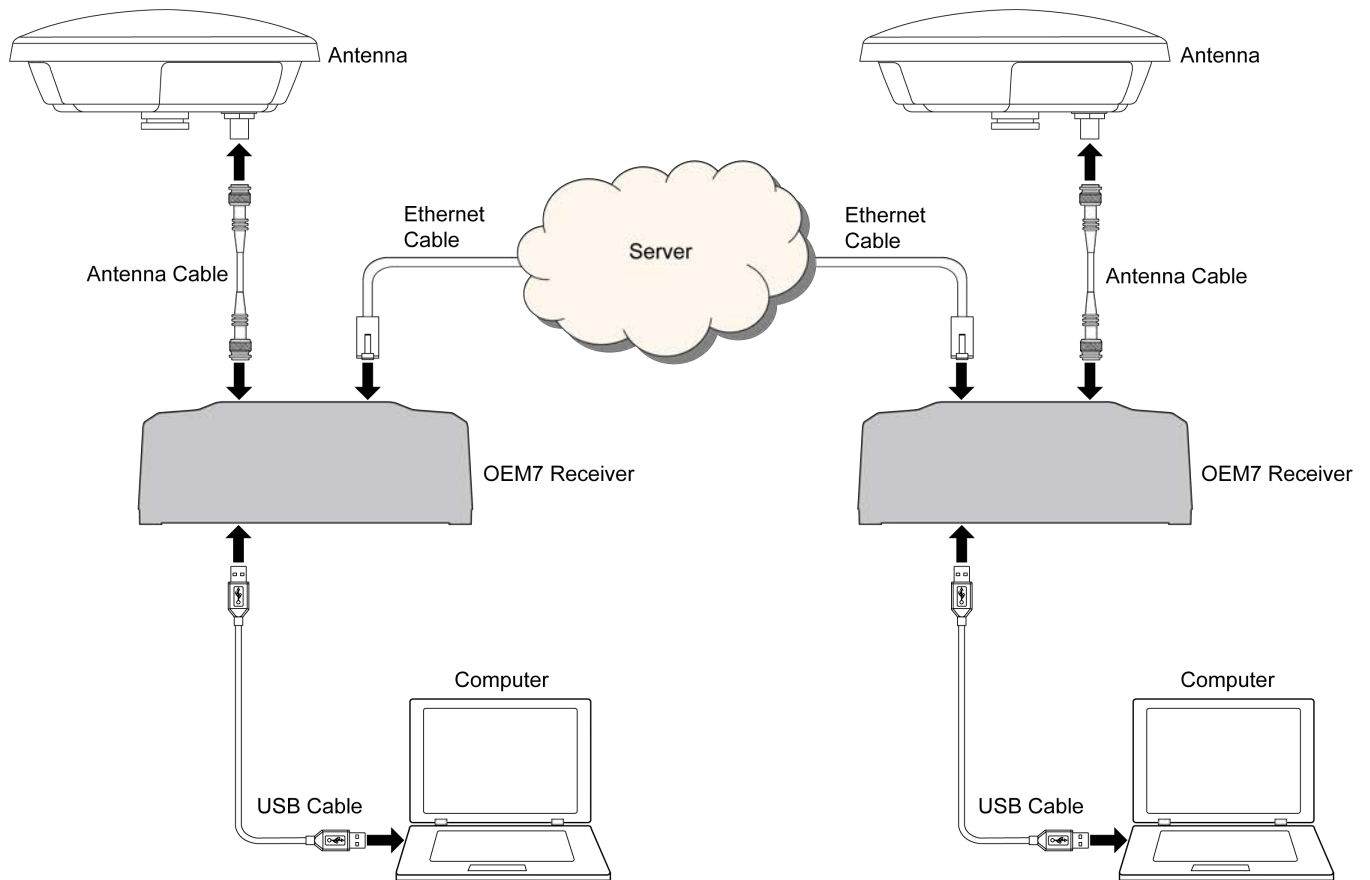

1. Connect your computer to both OEM7 receivers using null modem serial cables or USB cables.
2. Establish a connection to the receiver using either NovAtel Connect or another terminal program. This connection is used to send the commands in this procedure to the receivers.



For information about establishing a connection using NovAtel Connect, refer to the Help within NovAtel Connect.



NovAtel Connect version 2.0 or greater is required for OEM7 receivers. Download the latest NovAtel Connect software and documentation from www.novatel.com/novatel-connect.

3. Connect the power cables to both of the OEM7 receivers and apply power to the receivers.
4. Connect the Ethernet cables to the Ethernet ports on both OEM7 receivers.
5. Establish an Ethernet connection, either static or dynamic configurations. Refer to *Static IP Address Configuration* on page 99 or *Dynamic IP Address Configuration* on page 102 for more information.
6. Send the following commands to each receiver either through serial or USB ports:

Base:

```
FIX POSITION <lat> <long> <height>
INTERFACEMODE ICOM1 NONE RTCA off
LOG ICOM1 RTCAOBS2 ONTIME 1
```



```
LOG ICOM1 RTCAREF ONTIME 10
LOG ICOM1 RTCA1 ONTIME 5
SAVECONFIG
```

Rover:

```
ICOMCONFIG ICOM1 TCP <base ip address>:<base port #>
INTERFACEMODE ICOM1 RTCA NONE OFF
LOG BESTPOSA ONTIME 1 (optional)
SAVECONFIG
```

Use the **BESTPOS** log to confirm that the OEM7 rover is in RTK mode.

6.5 Large Ethernet Port Data Throughput

For high data rate Ethernet logging using TCP/IP, disable Windows Delayed Ack Algorithm (DAA) for complete data logging. If you do not disable DAA, there will be data gaps due to the Windows Ethernet buffer.



If done incorrectly, changing the Windows Registry may impair the operation of the computer. Editing the Windows Registry is for advanced Microsoft Windows users only. NovAtel Inc. is not able to provide any technical support for any actions taken regarding information found in Microsoft's Knowledge Base.

Chapter 7 NTRIP Configuration

An Ethernet capable OEM7 receiver can be configured as either an NTRIP server or an NTRIP client. An OEM7 receiver using a Wi-Fi connection can be configured as an NTRIP client. For more information about NovAtel's NTRIP, refer to www.novatel.com/products/firmware-options/ntrip/.

Figure 30: NTRIP System

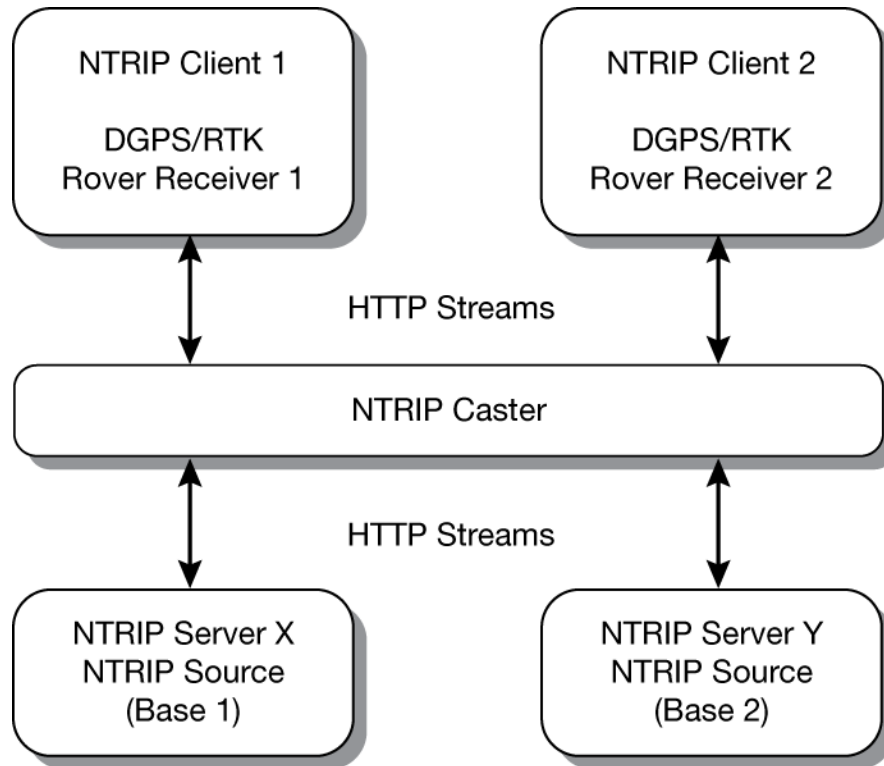



The NTRIP caster is an HTTP internet service that acts as a communication medium between NTRIP servers and NTRIP clients. The NTRIP caster is provided by third party sources. For a full list of NTRIP casters, refer to the following link: <http://www.rtcn-ntrip.org/home>.

7.1 NTRIP Configuration Over Ethernet

The following procedure describes how to configure a NovAtel base and a NovAtel rover through a third party NTRIP caster. This configuration is recommended for optimal RTK performance.

1. Establish a connection to the receiver using either NovAtel Connect or another terminal program. This connection is used to send the commands in this procedure to the receiver.

 For information about establishing a connection using NovAtel Connect, refer to the Help within NovAtel Connect.

 NovAtel Connect version 2.0 or greater is required for OEM7 receivers. Download the latest NovAtel Connect software and documentation from www.novatel.com/novatel-connect.

2. Connect the Ethernet cable to the Ethernet ports on both OEM7 receivers. For this setup, use a cross-over Ethernet cable.
3. Establish a static or dynamic Ethernet connection.
For information about creating the connection, refer to *Static IP Address Configuration* on page 99 or *Dynamic IP Address Configuration* on page 102.
4. Use the following commands to enable the base receiver as an NTRIP Server:

```
NTRIPCONFIG NCOM1 SERVER V2 <endpoint> <mountpoint> <username>
<password> ETHA
INTERFACEMODE NCOM1 NONE RTCA OFF
FIX POSITION <lat> <long> <height>
LOG NCOM1 RTCAOBS2 ONTIME 1
LOG NCOM1 RTCAREF ONTIME 10
LOG NCOM1 RTCA1 ONTIME 1
SAVECONFIG
```

5. Use the following commands to enable the rover receiver as an NTRIP Client:

```
ETHCONFIG ETHA AUTO AUTO AUTO AUTO
NTRIPCONFIG NCOM1 CLIENT V1 <endpoint> <mountpoint> <username>
<password > ETHA
```



If using a specific Network RTK system, certain National Marine Electronics Association (NMEA) strings are required to be sent from the rover back to the RTK network. For example, if connected to the VRS mount point, the rover is required to send its position to the network in a standard NMEA GGA message. This is achieved by issuing the following commands: **LOG NCOMx GPGGA ONTIME 5**, until data is received by the caster. For more information about Network RTK options and properties, refer to the application note [APN-041 Network RTK](#) and [APN-074: NTRIP on NovAtel OEM6/OEM7](#).

The following is an NTRIP Client configuration example without the use of a Network RTK system:

```
INTERFACEMODE NCOM1 RTCA NONE OFF
RTKSOURCE AUTO ANY
PSRDIFFSOURCE AUTO ANY
LOG BESTPOS ONTIME 1 (optional)
SAVECONFIG
```



Refer to the **NTRIPCONFIG** command in the [OEM7 Commands and Logs Reference Manual](#) for further command details.

Chapter 8 CAN Bus

The OEM7 receivers support the following CAN protocols:

- J1939 Transport and Extended Transport Protocol: used for corrections and NovAtel messages (both transmitting and receiving)
- NMEA2000: used for standard as well as NovAtel-proprietary messages (transmitting only)

By default, CAN is disabled on OEM7 receivers. Critical CAN configuration parameters such as Parameter Group Numbers (PGNs), addresses and priorities are system-specific and must be explicitly configured.

The addresses and PGNs are typically allocated when the overall CAN bus topology is determined. A Node has a unique CAN J1939 NAME and address.



The SPAN CPT7 has internal CAN transceivers, however it still requires proper bus terminations.

Refer to *SPAN CPT7 Connectors* on page 150 for pin-out information.

OEM7 receivers support the following NMEA2000 Parameter Group Messages (PGN) over the CAN bus:

- PGN 126992 System Time
- PGN 129025 GNSS Position Rapid Update
- PGN 129026 COG & SOG Rapid Update
- PGN 129027 Position Delta High Precision Rapid Update
- PGN 129029 GNSS Position
- PGN 129551 GNSS Differential Signal

The following commands and logs are used for CAN configuration:

- **CANCONFIG** command: controls the CAN transceiver hardware and places the receiver *on bus* or *off bus*
- **J1939CONFIG** command: assigns the CAN J1939 NAME and address parameters to a Node
- **J1939STATUS** log: reports the status a Node on the J1939 CAN network, such as the claimed address
- **LOG CCOMx PGNabcd**: configures the NMEA2000 messages
- **CCOMCONFIG** command: configures the parameters used by the NovAtel command interface to interact with the CAN Bus.



CCOM ports with a lower port number have a higher transmission priority.



For information about these commands, see the [OEM7 Commands and Logs Reference Manual](#).



Details for the PGN messages can be found in the NMEA2000 specification which can be purchased directly from the National Marine Electronics Association (www.nmea.org/).

8.1 Default Configuration

After a FRESET, the receiver has the following CAN configuration:

- All CAN physical ports are disabled
- No J1939 addresses are claimed
- CCOM ports are configured for NMEA2000 messages only

Table 13: Default NAME

Parameter	Value
Address	0x1C
Industry Group	2
Device Class	0
Device Class Instance	0
Function	23
Function Instance	0
ECU Instance	0
Manufacturer Code	305

8.2 Configuring the CAN Bus

To enable an OEM7 receiver to communicate over the CAN bus, configure CAN and place the receiver *on bus*, triggering a J1939 *Address Claim Procedure*.

1. Use the **J1939CONFIG** command to specify J1939 NAME and desired address.
This step is optional and only required if the default NAME parameters are to be changed.
2. Use the **CANCONFIG** command to place the receiver *on bus*.
3. Optionally, use the **J1939STATUS** log to monitor CAN status on the receiver.

8.2.1 Configuration Notes

- The **J1939CONFIG** and **CANCONFIG** commands can be entered in any order. After the **CANCONFIG** command is used to place the receiver on the CAN bus, **J1939CONFIG** commands take effect immediately. Until then, J1939CONFIG can be entered many times to change the settings because they have not taken affect yet (the receiver is not yet on the bus).
- The J1939 Address claim procedure is executed if and only if both J1939CONFIG NODEx CANx and CANCONFIG CANx ON are entered.
- Use J1939STATUS log to determine the receiver's CAN status and the actual address claimed by a particular node.
- Once the receiver is "on bus", it must be taken "off-bus" using CANCONFIG for any further configuration changes using J1939CONFIG.
- The receiver is fully "on-bus" only once the J1939 address has been successfully claimed. This is reported as "CLAIMED" status by J1939STATUS log.

- No messages will be sent or received until the receiver is "online" and an address is claimed. Outgoing messages are not buffered; they are discarded until the receiver is online.

8.2.2 Example of Enabling the CAN Bus

1. **LOG J1939STATUS ONCHANGED**
2. **J1939CONFIG NODE1 CAN1 <addresses>**
3. **CANCONFIG CAN1 ON 250K**
4. **SAVECONFIG**
 - < J1939STATUS NODE1 DISABLED 0 0xFE
 - < J1939STATUS NODE1 CLAIMING 1 <address>
 - < J1939STATUS NODE1 CLAIMED <attempt count> <address>

8.2.3 Example of Modifying the CAN Bus Parameters

1. **LOG J1939STATUS ONCHANGED**
2. **CANCONFIG CAN1 OFF**
3. **J1939CONFIG NODE1 CAN1 <addresses>**
4. **CANCONFIG CAN1 ON**
5. **SAVECONFIG**
 - < J1939STATUS NODE1 DISABLED 0 0xFE
 - < J1939STATUS NODE1 CLAIMING 1 <address>
 - < J1939STATUS NODE1 CLAIMED <attempt count> <address>

8.2.4 Example of Detecting an Address Claim Failure and Reconfiguring

1. **LOG J1939STATUS ONCHANGED**
2. **J1939CONFIG NODE1 CAN1 <addresses>**
3. **CANCONFIG CAN1 ON**
 - < J1939STATUS NODE1 DISABLED 0 0xFE
 - < J1939STATUS NODE1 CLAIMING 1 <address>
 - < J1939STATUS NODE1 FAILED <attempt count> 0xFE
4. **CANCONFIG CAN1 OFF**
 - < J1939STATUS NODE1 DISABLED 0 0xFE
5. **J1939CONFIG NODE1 CAN1 <addresses>**
6. **CANCONFIG CAN1 ON**
 - < J1939STATUS NODE1 CLAIMING 1 <address>
 - < J1939STATUS NODE1 CLAIMED <attempt count> <address>

8.2.5 Address Claim Procedure

To become operational on the CAN bus, an OEM7 receiver must claim a J1939 address. The preferred address and a range of alternative addresses are specified using the **J1939CONFIG** command. When a configured

receiver is placed *on bus*, it may make multiple attempts to claim an address. It may also have its address bumped by a higher priority device claiming the same address.

While the device is attempting to claim an address, the **J1939STATUS** log reports a status of *CLAIMING* and automatically tries to claim the next allowed address. Depending on the **J1939CONFIG** parameters, an address different from the **J1939CONFIG preferred address** may be claimed or the address claim procedure can fail entirely. If no addresses could be claimed, a *FAILED* status is reported and the receiver takes no further action. To recover from this failure, take the receiver *off bus* using the **CANCONFIG** command and change the CAN address configuration using the **J1939CONFIG** command.

The address can also be assigned using *J1939 Commanded Address* message sent by another ECU on the bus, such as a tester unit. The commanded address always overrides the address specified using **J1939CONFIG** command. When the *Commanded Address* is received, the receiver reports a status of *CLAIMING* followed by *CLAIMED*. Restarting CAN using the **J1939CONFIG** command or **CANCONFIG** command clears the commanded address; the Address Claim procedure will be executed again based on parameters specified in the **J1939CONFIG** command.

8.3 NMEA2000 Logging

OEM7 receivers support both a subset of the standard NMEA2000 PGNs, as well as NovAtel proprietary PGNs.

All NMEA2000 logs are configured using the **LOG** command, where the COM port is a CAN port (CCOM). The CCOM port must be associated with a J1939 node using the **CCOMCONFIG** command. If only NMEA2000 logs are needed, **CCOMCONFIG** parameters other than J1939NODE may be ignored.

To enable NMEA2000 logs:

1. Configure the CAN bus. See *Configuring the CAN Bus* on page 109.
2. Enable the CCOM port on the CAN bus node using the **CCOMCONFIG** command.
3. Enable the desired NMEA2000 logs.

NMEA2000 logs can be requested regardless of the on/off bus status of the receiver or the J1939 configuration. They are output if and only if the receiver is online.



The position for the **PGN129025**, **PGN129027** and **PGN129029** logs are reported in the user selected datum. See the **OUTPUTDATUM** command for more details.

8.3.1 Example of NMEA2000 Log Configuration

1. **CCOMCONFIG CCOM1 NODE1 NMEA2000**
2. **LOG CCOM1 PGN129025 ONTIME 0.5**
3. **LOG CCOM1 PGN129026 ONTIME 0.25**
4. **SAVECONFIG**

8.4 Corrections Over CAN

All NovAtel supported correction types are supported over CAN ports (CCOM).

To send or receive corrections:

1. Configure the CAN Bus. See *Configuring the CAN Bus* on page 109.
2. Use the **CCOMCONFIG** command to configure the PGN and other CAN parameters used by the RTK

corrections CAN messages.

PGN: Use the PGN designated for corrections.

Address:

- Use 0xFF to receive corrections from any CAN address and to broadcast corrections to all CAN nodes.
 - Use 0x00 to 0xFE to send corrections to or receive corrections from a specific CAN node.
3. Use the **INTERFACEMODE** command to configure the CCOM interface mode.
- To transmit corrections, use the desired INTERFACEMODE, e.g. RTCMV3
 - To receive corrections, it is recommended to use INTERFACEMODE AUTO.



Corrections configuration (**CANCONFIG** and **INTERFACEMODE**) for a particular CCOM port do not affect its NMEA2000 configuration. NMEA2000 logs coexist with correction messages, both incoming and outgoing.

8.4.1 Example for Receiving Corrections from Any Source

1. `CCOMCONFIG CCOM2 NODE1 J1939 61184 6 0xFF`
2. `INTERFACEMODE CCOM2 AUTO NONE OFF`

8.4.2 Example for Transmitting Corrections to 0x1C Node

1. `CCOMCONFIG CCOM2 NODE1 J1939 61184 6 0x1c`
2. `INTERFACEMODE CCOM2 NONE RTCMV3 OFF`

8.5 NovAtel Messages Over CAN

Standard NovAtel messages (commands, logs, responses) can be sent and received on the CAN Bus using CAN ports (CCOM). To reduce CAN Bus loading, NovAtel messages are sent using NovAtel standard binary format over J1939 (default).

The CCOM port requires special configuration and has the following limitations:

- A single CCOM port cannot be used for both Binary and ASCII / NovAtel ASCII messages.
- A single CCOM port cannot be used for both Binary messages and corrections.
- If the CCOM port is configured as *NOVATEL*, all input is interpreted as NovAtel ASCII or Abbreviated ASCII. Unlike other COM ports, the receiver will not distinguish between ASCII and binary input.
- To use CAN NOVATELBINARY, the CCOM port must be placed into NOVATELBINARY using the **INTERFACEMODE** command.



It is recommended to use one dedicated CCOM port for NovAtel messages and another dedicated CCOM port for corrections.



NovAtel UI configuration does not affect NMEA2000. Any CCOM port can be used for NMEA2000 logs irrespective of CCOMCONFIG settings.

To configure NovAtel User Interface over CAN:

1. Configure the CAN Bus. See *Configuring the CAN Bus* on page 109.
2. Use the **CCOMCONFIG** command to configure the PGN and other CAN parameters.
3. Use the **INTERFACEMODE** command to configure the CCOM port for **NOVATELBINARY**.

Example: Configuring CCOM2 for NovAtel messages:

1. **CCOMCONFIG CCOM2 NODE1 1234 6 0x1C**
2. **INTERFACEMODE CCOM2 NOVATELBINARY NOVATELBINARY OFF**

8.6 Configuring OEM7 Receivers to Use OEM6 CAN Settings

CAN Bus functionality has been enhanced on OEM7 receivers. To accommodate the enhancements in functionality and flexibility, several new commands and logs have been added. Also, the **SETCANNNAME** command has been removed and the **CANCONFIG** command has been modified.

The following sections describes how to configure CAN on OEM7 receivers to operate like OEM6 receivers.

8.6.1 Configuration on OEM6

On OEM6 receivers, the **SETCANNNAME** command, with minimal parameters, could be used to configure CAN.

```
SETCANNNAME 305
```

Once entered, a limited address claim procedure would take place and NMEA2000 logs would be generated automatically at a fixed logging rate and fixed CAN port bit rate.

8.6.2 Configuration on OEM7

To configure an OEM7 receiver to log the same commands and use the same logging rate and CAN port bit rate, enter the following commands:

```
CCOMCONFIG CCOM1 NODE1 NMEA2000
CANCONFIG CAN1 ON 250K
LOG CCOM1 PGN129025 ONTIME 0.1
LOG CCOM1 PGN129026 ONTIME 0.1
LOG CCOM1 PGN129027 ONTIME 0.1
LOG CCOM1 PGN129029 ONTIME 1.0
SAVECONFIG
```

On OEM7 receivers, nothing is automatically logged when CAN is enabled. Regular log requests must be made for each log required.

A full address claim procedure with default values is initiated with the **CANCONFIG ON** command. The J1939CONFIG command can be used to modify the default address claim parameters including the ManufacturingCode (set to 603 in the SETCANNNAME example above, now defaults to 305 in the new J1939CONFIG) but it's not necessary.

Chapter 9 Built-In Status Tests

The Built-In Status Test monitors system performance and status to ensure the receiver is operating within specifications. The test detects an exceptional condition and informs the user through one or more indicators. The receiver status system is used to configure and monitor the indicators:

1. Receiver status word (included in the header of every message)
2. RXSTATUSEVENT log
3. RXSTATUS log

When an unusual and non-fatal event occurs (for example, there is no valid position solution), a bit is set in the receiver status word. Receiver operation continues normally. When the event ends (for example, when there is a valid position solution), the bit in the receiver status word is cleared.

When a fatal event occurs (for example, a receiver hardware failure), a bit is set in the receiver error word, part of the **RXSTATUS** log, to indicate the cause of the problem. Bit 0 is set in the receiver status word to show that an error occurred. An **RXSTATUSEVENT** log is generated on all ports to show the cause of the error. Receiver tracking is disabled but command and log processing continues to allow error diagnosis. Even if the source of the error is corrected, the receiver must be reset to resume normal operation.

These two scenarios describe factory default behavior. These behaviors can be customized to better suit an individual application. RXSTATUSEVENT logs can be disabled completely with the **UNLOG** command.

RXSTATUSEVENT logs can be generated when a receiver status bit is set or cleared with the **STATUSCONFIG SET** and **STATUSCONFIG CLEAR** commands. Bits in the receiver status word can also be promoted to act like error bits with the **STATUSCONFIG PRIORITY** command.

9.1 Receiver Status Word

The receiver status word indicates the current status of the receiver. This word is found in the header of all logs and in the **RXSTATUS** log. In addition, the receiver status word is configurable.

The importance of the status bits can be determined with priority masks. For receiver status, setting a bit in the priority mask causes the condition to trigger an error. The error causes the receiver to idle all channels, turn off the antenna and disable the RF hardware, just like it would if a bit in the receiver error word is set. Setting a bit in an Auxiliary Status priority mask causes the condition to set the bit in the receiver status that corresponds to the auxiliary status.

Use the **STATUSCONFIG** command to configure the various status mask fields in the **RXSTATUS** log. Use the masks to specify whether various status fields generate errors or event messages when set or cleared.

Refer to the **RXSTATUS** log, **RXSTATUSEVENT** log and **STATUSCONFIG** command in the [OEM7 Commands and Logs Reference Manual](#) for more detailed descriptions of these messages.

9.2 RXSTATUSEVENT Log

The **RXSTATUSEVENT** log is used to output event messages, as indicated in the **RXSTATUS** log.

On start up, the OEM7 receiver is set to log **RXSTATUSEVENTA ONNEW** on all ports. You can remove this message using the **UNLOG** command.

Refer to the **RXSTATUSEVENT** log in the [OEM7 Commands and Logs Reference Manual](#) for log and command details. for a more detailed description of this log.

9.3 RXSTATUS Log

The Receiver Status log (RXSTATUS) provides system status and configuration information in a series of hexadecimal words.

9.3.1 Status Word

The status word is the third field after the header, as shown in the example in *Figure 31: Location of Receiver Status Word* below.

Figure 31: Location of Receiver Status Word

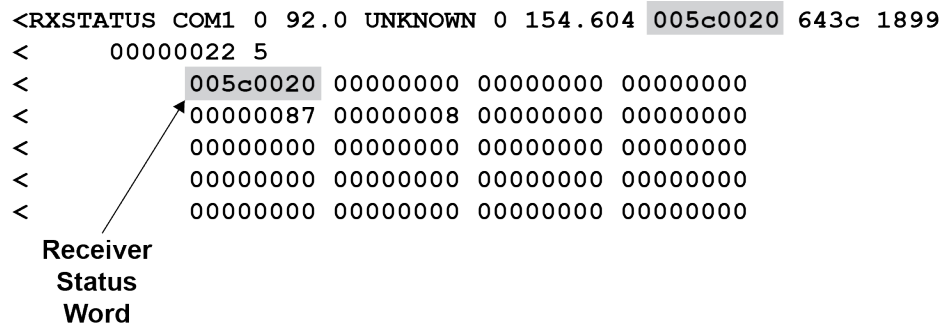

Each bit in the status word indicates the status of a specific receiver condition or function. If the status word is 00000000, the receiver is operating normally. The numbering of the bits is shown in *Figure 32: Reading the Bits in the Receiver Status Word* below.

Figure 32: Reading the Bits in the Receiver Status Word

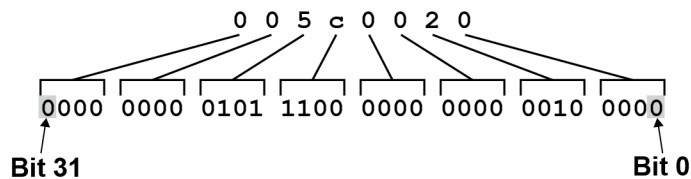

If the receiver status word indicates a problem, see *Examining the RXSTATUS Log* on page 119.

9.3.2 Error Word

The error field contains a 32-bit word. Each bit in the word is used to indicate an error condition. Error conditions may result in damage to the hardware or erroneous data, so the receiver is put into an error state. If any bit in the error word is set, the receiver broadcasts the **RXSTATUSEVENT** log on all ports (unless the user has unlogged it), idles all channels, turns the antenna off and disables the RF hardware. To override the error state, reset the receiver.

The receiver can be configured to generate event messages triggered by status conditions. Receiver Error words automatically generate event messages. These event messages are output in the **RXSTATUSEVENT** log (see also *Set and Clear Mask for all Status Code Arrays* on page 117).

The error word is the first field after the log header in the **RXSTATUS** log, as shown in the example in *Figure 33: Location of Receiver Error Word* on the next page.

Figure 33: Location of Receiver Error Word

```

<RXSTATUS COM1 0 92.0 UNKNOWN 0 154.604 005c0020 643c 1899
< 00000022 5
< 005c0020 00000000 00000000 00000000
< 00000087 00000008 00000000 00000000
< 00000000 00000000 00000000 00000000
< 00000000 00000000 00000000 00000000
< 00000000 00000000 00000000 00000000

```

Receiver
Error
Word

Figure 34: Reading the Bits in the Receiver Error Word below shows an example of a receiver error word.

Figure 34: Reading the Bits in the Receiver Error Word

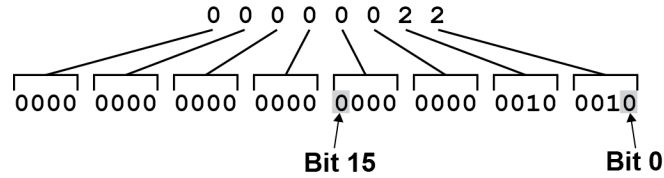

Refer to the **RXSTATUS** log and **RXSTATUSEVENT** log in the [OEM7 Commands and Logs Reference Manual](#) for more detailed log descriptions. If the receiver error word indicates an error, refer to *Examining the RXSTATUS Log* on page 119.

9.3.3 Status Code Arrays

There are currently 5 status code arrays:

- receiver status word
- auxiliary 1 status
- auxiliary 2 status
- auxiliary 3 status
- auxiliary 4 status

Each status code array consists of four 32-bit words (the status word, a priority mask, a set mask and a clear mask). The status word is similar to the error word, with each of the 32 bits indicating a condition. The priority mask words are used to modify the behavior caused by a change in one of the bits in the associated status words. Each bit, in any mask, operates on the bit in the same position in the status word. For example, setting bit 3 in the priority mask changes the priority of bit 3 in the status word.

Figure 35: Status Code Arrays

```

<RXSTATUS COM1 0 92.0 UNKNOWN 0 154.604 005c0020 643c 1899
<    00000022 5
<    005c0020 00000000 00000000 00000000 ← Receiver Status
<    00000087 00000008 00000000 00000000 ← Auxiliary 1 Status
<    00000000 00000000 00000000 00000000 ← Auxiliary 2 Status
<    00000000 00000000 00000000 00000000 ← Auxiliary 3 Status
<    00000000 00000000 00000000 00000000 ← Auxiliary 4 Status

```

↑
↑
↑
↑

Status **Priority** **Set** **Clear**
Word **Mask** **Mask** **Mask**

9.3.4 Receiver Status Code

The receiver status word is included in the header of all logs. It has 32 bits that indicate certain receiver conditions. If any of these conditions occur, a bit in the status word is set. Unlike the error word bits, the receiver continues to operate, unless the priority mask for the bit has been set. The priority mask bit changes the bit in the receiver status word into an error bit. Anything that results from an error bit becoming active also occurs if a receiver status and its associated priority mask bits are set.

9.3.5 Auxiliary Status Codes

The auxiliary status codes are only in the **RXSTATUS** log. The four arrays that represent the auxiliary status codes indicate the receiver state for information purposes only. The events represented by these bits typically do not cause receiver performance degradation. The priority mask for the auxiliary codes does not put the receiver into an error state. Setting a bit in the auxiliary priority mask results in the corresponding bit in the receiver status code to be set if any masked auxiliary bit is set. Bit 31 of the receiver status word indicates the condition of all masked bits in the auxiliary 1 status word. Likewise, bit 30 of the receiver status word corresponds to the auxiliary 2 status word and bit 29 to the auxiliary 3 status word.

Refer also to the **RXSTATUS** log in the [OEM7 Commands and Logs Reference Manual](#) for a more detailed description.

9.3.6 Set and Clear Mask for all Status Code Arrays

The other two mask words in the status code arrays operate on the associated status word in the same way. These mask words are used to configure the bits in the status word that result in a **RXSTATUSEVENT** log broadcast. The set mask is used to turn logging on temporarily while the bit changes from the 0 to 1 state. The clear mask is used to turn logging on temporarily while the bit changes from a 1 to a 0 state. Note the error word does not have any associated mask words. Any bit set in the error word results in a **RXSTATUSEVENT** log broadcast (unless unlogged).

Refer also to the **RXSTATUS** log in the [OEM7 Commands and Logs Reference Manual](#) for a more detailed description.

Chapter 10 Troubleshooting

There are simple ways to diagnose and resolve problems. In many cases, the issue can be resolved within a few minutes, avoiding the inconvenience and loss of productivity that results from having to return the receiver for repair. This section discusses troubleshooting issues and includes cross-references to other sections of the manual that may help resolve problems.

If unsure of the symptoms or if the symptoms do not match any of those listed, use the RXSTATUS log to check the receiver status and error words. See *Examining the RXSTATUS Log* on the next page.

Try to resolve the problem using the troubleshooting guide in *Table 14: Troubleshooting Based on Symptoms* below, then try our Knowledge Base at www.novatel.com/support/. If you are still not able to resolve the problem, see *Customer Support* on page 17 for troubleshooting logs and contact information.

Table 14: Troubleshooting Based on Symptoms

Symptom	Related Section
The receiver is not properly powered	Check the power cable. Replace if faulty. See <i>Power Supply Requirements for the SPAN CPT7</i> on page 24
The receiver cannot establish communication	Check the serial cables and ports. Replace if faulty. See <i>CAN Bus</i> on page 108. Refer also to the SERIALCONFIG command.
The receiver is not tracking satellites	Ensure that the antenna has an unobstructed view of the sky from horizon to horizon. Check the RXSTATUS error states. See <i>Examining the RXSTATUS Log</i> on the next page. If the receiver is in error mode, it does not track. Use the Interference Toolkit to check if there is an interference signal present. See <i>Interference Toolkit</i> on page 55. Check the antenna cable. Replace if faulty. See <i>Selecting a GNSS Antenna</i> on page 23 and <i>Choosing a Coaxial Cable</i> on page 24.
No data is being logged	Refer to <i>CAN Bus</i> on page 108 and <i>Communications with the Receiver</i> on page 36
Random data is being output by the receiver or binary data is streaming	Check the baud rate on the receiver and in the communication software. Refer to the SERIALCONFIG command and FRESET command. See also <i>CAN Bus</i> on page 108.
A command is not accepted by the receiver	Check for correct spelling and command syntax. See <i>Communications with the Receiver</i> on page 36 and refer to the FRESET command in the OEM7 Commands and Logs Reference Manual

Symptom	Related Section
Differential mode is not working properly	See <i>Transmitting and Receiving Corrections</i> on page 41 and refer to the SERIALCONFIG command.
There appears to be a problem with the receiver's memory	Refer to the NVMRESTORE command.
An environmental or memory failure. The receiver temperature is out of acceptable range or the internal thermometer is not working	Move the receiver to within an acceptable temperature range. See: <ul style="list-style-type: none"> • <i>High Temperature Environments</i> on page 123 • <i>SPAN CPT7 Electrical and Environmental Specifications</i> on page 146
Overload and overrun problems. Either the CPU or port buffers are overloaded	Reduce the amount of logging or increase the baud rate.
The receiver is indicating that an invalid authorization code has been used	Refer to the VERSION log or VALIDMODELS log and the MODEL command or AUTH command.
The receiver is being affected by jamming	Move the receiver away from any possible jamming sources
The receiver is being affected by interference	See <i>Interference Toolkit</i> on page 55. Move the GNSS antenna away from the source of the interference signal. If the interference mitigation feature is enabled on the receiver, configure a filter within the Interference Toolkit to filter out the interference signal.
The receiver's Automatic Gain Control (AGC) is not working properly	See the jamming symptom in this table

For information about the commands and logs in this section, refer to the [OEM7 Commands and Logs Reference Manual](#).

10.1 Examining the RXSTATUS Log

The RXSTATUS log provides detailed status information about your receiver and can be used to diagnose problems. Refer to the **RXSTATUS** log for details on this log and on how to read the receiver error word and status word. *Table 15: Resolving a Receiver Error Word* below, *Table 16: Resolving an Error in the Receiver Status Word* on page 121 and *Table 17: Resolving an Error in the AUX1 Status Word* on page 122 have actions to take when your receiver has an error flag in these words. If you are not able to resolve the condition, contact *Customer Support* on page 17.

Table 15: Resolving a Receiver Error Word

Bit Set	Action to Resolve
0-2	Issue a FRESET command (for bit 1, reload new firmware).

Bit Set	Action to Resolve
4	Contact <i>Customer Support</i> on page 17.
5	Check the VERSION log. The VERSION log will indicate "Invalid authcode". Upgrade the auth-code as described in <i>Upgrading Using an Auth-Code</i> on page 137.
6	Issue a FRESET command
7	See <i>Power Supply Requirements for the SPAN CPT7</i> on page 24
8	Reserved
9	<p>Check the temperature ranges in:</p> <ul style="list-style-type: none"> • <i>SPAN CPT7 Electrical and Environmental Specifications</i> on page 146 <div data-bbox="293 638 1451 856" style="border: 1px solid black; padding: 10px; margin: 10px 0;">  <p>The operating temperatures are ambient air temperatures. The temperature sensors on the receiver PCB will reflect higher operating temperatures (refer to the HWMONITOR log). The PCB temperature sensors will trigger a receiver warning and receiver error at 100°C and 110°C respectively. The warning and error conditions are captured using the RXSTATUS log.</p> </div>
10	Possible hardware or environmental condition. If you cannot resolve the problem, contact <i>Customer Support</i> on page 17.
11	<p>Possible hardware or environmental condition. If you cannot resolve the problem, contact <i>Customer Support</i> on page 17.</p> <p>Also, check the Auxiliary 2 Status word to determine which PLL is in error.</p>
12-14	Reserved
15	Issue a FRESET command and power cycle the unit. If the bit is still present, contact <i>Customer Support</i> on page 17.
16	Monitor CPU idle time. Reduce number of logs or the rate of data logging.
17	Ensure that the Version log is consistent with the hardware.
18-19	Reserved
20	SoftLoad is in progress. See <i>Updating Using SoftLoad Commands</i> on page 131.
21	You may be exceeding the receiver's velocity limit. If so, reduce velocity. This error can only be cleared by resetting the receiver.
22	Reload firmware using WinLoad or the SoftLoad commands.
23-30	Reserved
31	Possible hardware failure. Contact <i>Customer Support</i> on page 17.

Table 16: Resolving an Error in the Receiver Status Word

Bit Set	Action to Resolve
0	Check the Error Word in the RXSTATUS log. See also <i>Table 15: Resolving a Receiver Error Word</i> on page 119
1	Check the temperature ranges in <ul style="list-style-type: none"> • <i>SPAN CPT7 Electrical and Environmental Specifications</i> on page 146
2	See <i>Power Supply Requirements for the SPAN CPT7</i> on page 24
3	See <i>Selecting a GNSS Antenna</i> on page 23, <i>Choosing a Coaxial Cable</i> on page 24, <i>Antenna LNA Power</i> on page 26
4	
5	
6	
7	Check the CPU idle time. Check for unnecessary logging. Check for simultaneous use of functionality.
8	See <i>Table 4: Serial Ports Supported</i> on page 38 Also, check the Auxiliary 2 Status word to determine which COM port has overrun its buffer.
9-11	Reserved
15	Check the Auxiliary 1 status word to determine which RF channels are jammed.
16-17	Reserved
18	When the receiver has tracked GNSS satellites long enough for a valid almanac to be received, this bit will be set to 0.
19	None. This bit only indicates if the receiver has calculated a position.
20	None. This bit is a status bit indicating if the receiver's position has been manually fixed and does not represent a problem. Refer also to the FIX command.
21	None. This bit indicates if c.lock steering has been manually disabled. Refer also to the FRESET command.
22	None. This bit only indicates if the clock model is valid. Refer also to the FRESET command.
23	None. This bit indicates if the phase-lock-loop is locked when using an external oscillator. Refer also to the FRESET command.
24	Check the CPU idle time. Check for unnecessary logging. Check for simultaneous use of functionality.
25-26	None. These bits identify the receiver family. For OEM7 receivers, bit 25 is set to 1 and bit 26 is set to zero.
27	Interference Toolkit HDR mode status. When this bit is set to 1, Interference Toolkit HDR mode is enabled.
28	Digital filter status. When this bit is set to 1, an Interference Toolkit digital filter is enabled.

Bit Set	Action to Resolve
29	None. This bit indicates if any bits in the auxiliary 3 status word are set. The auxiliary 3 word provides status information and does not contain any new information on problems. Refer also to the FRESET command.
30	None. This bit indicates if any bits in the auxiliary 2 status word are set. The auxiliary 2 word provides status information and does not contain any new information on problems. Refer also to the FRESET command.
31	None. This bit indicates if any bits in the auxiliary 1 status word are set. The auxiliary 1 word provides status information and does not contain any new information on problems. Refer also to the FRESET command.

For information about the commands and logs in this section, refer to the [OEM7 Commands and Logs Reference Manual](#).

10.2 Examining the AUX1 Status Word

Table 17: *Resolving an Error in the AUX1 Status Word* below provides actions to take when your receiver has an error flag in the AUX1 status word.

Table 17: Resolving an Error in the AUX1 Status Word

Bit Set	Action to Resolve
0-2	Jammer detected
3	None. This bit indicates that Position Averaging is ON
4-6	Jammer detected
7	Connect the receiver via USB
8-10	Reduce the amount of logging on the USB ports
11	(Reserved bit)
12	None. This bit indicates a Profile set using the PROFILE command is activated.
13	Throttled Ethernet Reception Check for unusually high Ethernet traffic being directed to the Receiver. This does not represent an error condition on the receiver, but suggests there may be an issue in the network environment on the receiver.
14-17	AGC error on RF1 through RF4 respectively. To resolve, ensure the antenna cable is connected and signal input level is within specification. Contact NovAtel <i>Customer Support</i> on page 17 for additional information.
18	Connect the receiver via Ethernet. See <i>Ethernet Port</i> on page 32
19-21	Reduce the amount of logging on the Ethernet ports

Bit Set	Action to Resolve
22-24	Reduce the amount of logging on the NTRIP ports
25-27	Reduce the amount of logging on the Virtual COM ports
28-29	AGC error on RF5 (bit 28) or RF6 (bit 29). To resolve, ensure the antenna cable is connected and signal input level is within specification. Contact NovAtel <i>Customer Support</i> on page 17 for additional information.
30-31	(Reserved bits)

10.3 High Temperature Environments

The operating temperature of OEM7 receivers increases as more features (channels used, HDR mode, etc.) are enabled.

When the receiver is operating in an environment that is near its maximum ambient temperature, an increase in the ambient air temperature or enabling additional features may cause the receiver to exceed its maximum operating temperature and generate a Temperature Status error. When a Temperature Status error occurs, the receiver idles all channels, turns off the antenna and disables the RF hardware. The communication interfaces continue to function so commands can be sent and logs received.

10.3.1 Indicators of an Error State

The indications that the receiver is in an error state, such as a Temperature Status error, are:

- Logs that have a solution status will show `INSUFFICIENT_OBS` as the Solution Status.
- The **RXSTATUSEVENT** log is output on all communication ports. This log will indicate an error condition in the Receiver Error word of the log.
- All logs output have Bit 0 set in the Receiver Status word of the log header.

To determine the cause of the error, log the **RXSTATUS** log and check the Receiver Error word. If Bit 9 is set, it is a Temperature Status error. For information about reading the Error Word, refer to *Error Word* on page 115.

10.3.2 Recovering from a Temperature Status Error

The receiver must be reset or power cycled to recover from a receiver error such as a Temperature Status error.

Log information is lost when the receiver is reset. Therefore, any logs required to identify and troubleshoot the error, such as the **RXSTATUS** log, should be collected before resetting the receiver.

Also, steps should be taken to reduce the cause of the receiver temperature error to prevent the error from occurring again. See *Mitigating High Receiver Temperature* below.

10.3.3 Mitigating High Receiver Temperature

If the receiver has a high temperature warning or error, use one or more of the following suggestions to reduce the receiver temperature.

- If possible, reduce the ambient temperature around the receiver or move the receiver to an area with a lower ambient temperature.
- Disable the receiver features that are not required for the current operation of the receiver.

10.4 Safe Mode

Safe Mode is an error condition triggered on the OEM7 receiver if it encounters certain critical problems during start-up. The receiver does not track GNSS satellites in this state, but the user interface is still available to allow for diagnosis of the problem.

The receiver will enter Safe Mode under certain rare cases including the following:

- Corrupted or bad data within the receiver Non-Volatile Memory (NVM).
- An unsupported Auth Code.
- The expected main firmware image could not be found by the boot code. This is possibly due to an error during the main firmware loading process (i.e. WinLoad, SoftLoad, etc.).

Safe Mode exists to allow users to take steps to recover the receiver after such an error occurs. Potential recovery steps are described in *Recovery Steps* below.

Safe Mode is indicated by an error bit in the **RXSTATUS** log.

10.4.1 Reset Loop Detection

In order to determine when the Safe Mode error should be triggered, OEM7 receivers have the ability to detect when an unexpected reset has occurred during the boot process. If a Reset Loop is detected, the **Reset Loop Detected** bit is set in the **RXSTATUS** log.

This bit is only a warning and the receiver may still be able to operate correctly. The receiver will allow several unexpected resets to occur before triggering the Safe Mode Error, at which point the receiver will not track GNSS satellites.

10.4.2 Recovery Steps

If the **Safe Mode** error bit or the **Reset Loop Detected** warning bit are set in the **RXSTATUS** log, take the following steps to diagnose and recover the system:

1. Request the **SAFEMODESTATUS** log and determine the current *Safe Mode State* of the system.
2. Reference Table: Safe Mode States in the [OEM7 Commands and Logs Reference Manual](#) and find the suggested actions for the current Safe Mode State.
3. If the suggested actions do not resolve the issue, contact NovAtel Customer Support.

Chapter 11 NovAtel Firmware and Software

Download the most recent versions of the NovAtel firmware and receiver software from the Downloads section of www.novatel.com/support/search/.

NovAtel Software

NovAtel software applications run on a computer and are used to interact with NovAtel receivers. The following software is available from the NovAtel website:

- NovAtel Connect (a GUI interface)
- Convert (converts receiver data logs into different formats)
- USB Drivers

NovAtel software is available in Windows compatible and Unix compatible versions. For information about using NovAtel Connect or Convert, refer to the help system available within the application.



NovAtel Connect version 2.0 or greater is required for OEM7 receivers. Download the latest NovAtel Connect software and documentation from www.novatel.com/novatel-connect.

NovAtel Firmware

NovAtel firmware runs on NovAtel receivers. It provides the features and functionality available on the receiver.

The firmware download file contains:

- Firmware *.shex file
- WinLoad software utility

11.1 Firmware Updates and Model Upgrades

A local NovAtel dealer can provide all the information needed to upgrade or update a receiver. Refer to www.novatel.com/where-to-buy for contact information or contact sales@novatel.com or support@novatel.com directly.

11.1.1 Firmware Updates

Firmware updates are firmware releases that include fixes and enhancements to the receiver functionality. Firmware updates are released on the NovAtel web site as they become available. Firmware upgrades can be performed using the WinLoad utility, SoftLoad commands, NovAtel Web UI, NovAtel Connect or with a custom loader application. Contact NovAtel Customer Support (support@novatel.com) for details on custom loader requirements.

11.1.2 Model Upgrades

Model upgrades enable purchased receiver features.

Contact a local NovAtel dealer to assist in selecting the upgrade options that best suit your GNSS needs at www.novatel.com/where-to-buy. Contact NovAtel Customer Support www.novatel.com/support or [NovAtel Sales](#) to request a temporary upgrade authorization code for trial purposes.

Model upgrades can be applied to the receiver with an authorization code and the **AUTH** command without returning the receiver to the dealer.

11.2 Authorization Code

An authorization code, commonly known as an auth-code, is required to upgrade an OEM7 receiver. Auth-codes are obtained by contacting [NovAtel Customer Support](#). Upon contact, NovAtel Customer Support requires:

- the receiver model number
- the receiver serial number
- the receiver firmware version

Enter the **LOG VERSION** command to determine the receiver model, serial number and firmware version.

Example:

```

ENTER → MODEL SERIAL FIRMWARE
        NUMBER NUMBER VERSION
GPSCARD "CFNPNTVN" "BMGX15360001Z" "OEM729-0.00H" "OM7MR0000RN0000"
                                                | | |
                                                | | |
                                         PRODUCT FIRMWARE RELEASE
                                         FAMILY NUMBER INDICATOR
  
```

After determining the appropriate model and firmware version, the authorization code (auth-code) is issued. The auth-code is required to unlock the features on the new model type.

To upgrade to a new model with the same firmware version, use the **AUTH** command with the issued auth-code, as outlined in *Upgrading Using an Auth-Code* on page 137.

To upgrade to a new model with a new firmware version, the new firmware needs to be loaded into the OEM7 receiver. For instructions, refer to *Updating or Upgrading Using the WinLoad Utility* on the next page, *Updating the Firmware Using NovAtel Connect* on page 130, *Updating the Firmware Using NovAtel Web UI* on page 131 or *Updating Using SoftLoad Commands* on page 131.

Auth-codes work with any signed firmware image. Therefore, if a receiver has an auth-code for the old version of firmware, that same auth-code will work for the new version of firmware, provided both images are digitally signed by NovAtel.

Signed firmware images are distributed in *.shex files. The new download package includes a signed firmware file type that uses an extension designated as ".shex" (example OM7MR0200RN0000.shex), as well as the latest WinLoad utility and What's New file containing firmware update change details.

Temporary auth-codes may be provided by NovAtel for evaluation purposes. Once the trial period has expired, the functionality provided by the auth-code is removed. The expiration date for temporary auth-codes is in the form YYMMDD, where YY = year, MM = month and DD = day. The date is the last day that the auth-code is valid and expires at the end of day, UTC time.

Once the trial period has expired, a new auth-code will need to be obtained from NovAtel Customer Support (support@novatel.com).

Firmware images may also have auth-codes embedded within them. The models provided by such firmware images will be valid only on receivers with certain PSNs and Hardware Versions.

11.3 Downloading Firmware Files

To proceed with an update or possibly an upgrade, obtain the latest version of firmware by downloading the firmware file for your product from www.novatel.com/support/firmware-downloads/.



If the receiver is an H-model, do not use the firmware available from the web site. Contact *Customer Support* on page 17 to obtain the correct firmware.

11.3.1 Format of Firmware Files

All of the firmware available on the downloads website are packaged in .zip files with the following name:

- 7XXXX-Firmware.zip for firmware to be installed on OEM7 receivers

For convenience, unzip the update file to a GNSS sub-directory (for example, C:\GNSS\LOADER). If the firmware update file is password protected, NovAtel Customer Support provides the required password.

The zip archive includes the following files:

winload.exe	WinLoad utility program
howto.txt	Instructions on how to use the WinLoad utility
whatsnew.rtf	Information on the changes made in the firmware since the last revision
x..x.shex	Firmware version upgrade file, where x..x defines the product name and release (e.g., OM7MR0200RN0000.shex)
NovAtel Software License Agreement.rtf	License agreement for the firmware



NovAtel has an online video tutorial that explains firmware updating at: www.novatel.com/support/videos.

11.4 Updating or Upgrading Using the WinLoad Utility

WinLoad is a utility used to update or upgrade an OEM7 receiver. To use WinLoad, the receiver must be connected to the computer running WinLoad using a serial port (COM port) connection.

11.4.1 Using the WinLoad Utility

If opening WinLoad for the first time, ensure the file and communications settings are correct.

Open a File to Download

Select File | File Open. Navigate to the file to open (*Figure 36: WinLoad's Open Window* on the next page).

Figure 36: WinLoad's Open Window

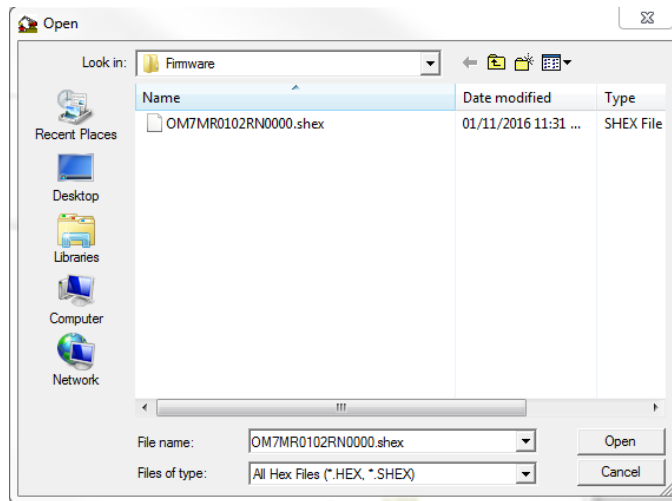

When a file is selected, the *filename* appears in the main WinLoad display area and in the title bar (Figure 37: Open File in WinLoad below).

Figure 37: Open File in WinLoad

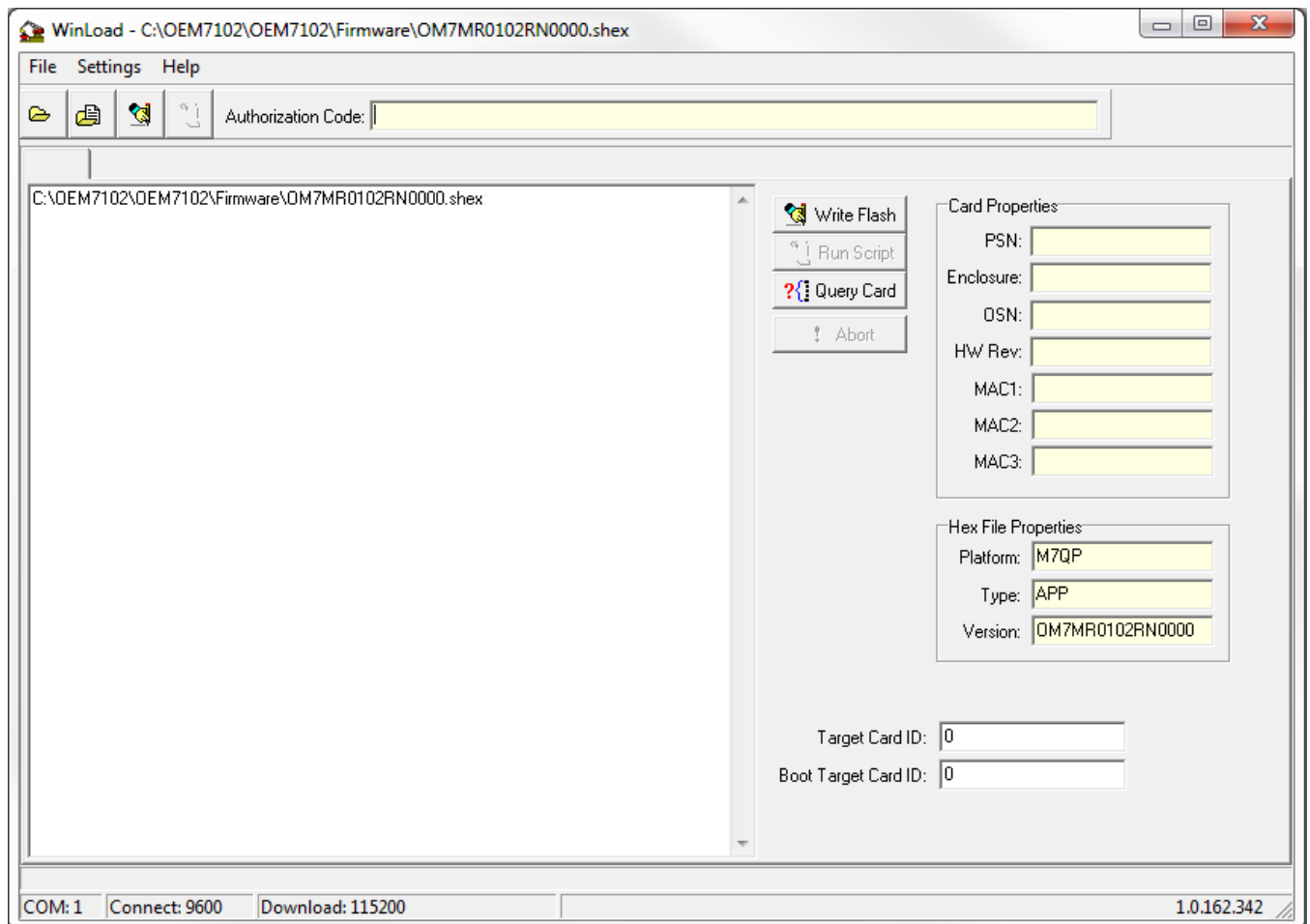

Communications Settings

To set the communications port and baud rate, select Settings | COM Settings. Choose the computer port to use from the Com Port drop down list and the baud rate from the Download Baudrate drop down list. Set the baud rate as high as possible (the default of 115200 is preferred if a higher baud rate is not available).

Figure 38: COM Port Setup

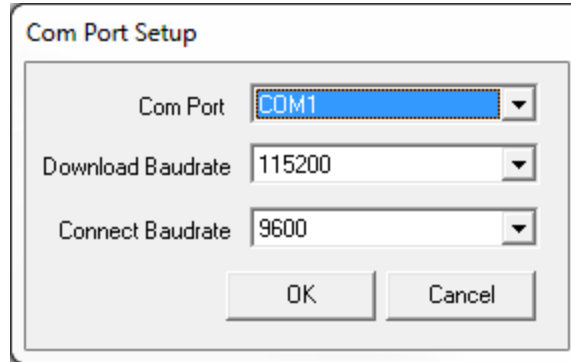

Downloading Firmware

1. Select the file to download according to *Open a File to Download* on page 128.
2. Ensure the file path and name are displayed in main display area (see *Figure 37: Open File in WinLoad* on the previous page).
3. Click **Write Flash** to download the firmware.
4. When *Searching for card* appears in the main display, power cycle the receiver.
5. If the Authorization Code window appears, enter the auth-code and click **OK**. See *Authorization Code* on page 127 for further information about the Authorization Code.
6. The receiver finishes the download and then resets. The process is complete when *Done* appears in the main display area.
7. Close WinLoad.



If loading a firmware that is currently installed on an OEM7 receiver (i.e. reloading the same version of firmware on a receiver), ensure that *Optimized Loading* option is unchecked in WinLoad under *Settings | Options | Optimized Loading*.

11.5 Updating the Firmware Using NovAtel Connect

To use NovAtel Connect to update the receiver firmware, the receiver must be connected to the computer running NovAtel Connect using a serial (COM) port, USB port or Ethernet port.

To update the firmware on the receiver:

1. Obtain the new firmware file.

See *Downloading Firmware Files* on page 127 for information about obtaining the latest version of receiver firmware.



Copy the firmware file to the computer's local drive before uploading.

2. Connect a computer to the receiver using a serial (COM) cable, USB cable or Ethernet connection.
3. Start NovAtel Connect on the computer.
4. Use NovAtel Connect to connect to the receiver.
For information about using NovAtel Connect, refer to the help file in NovAtel Connect.
5. Click the **Firmware Update** button.
The Update window appears.
6. Click the **CHOOSE FILE** button.
7. Navigate to the directory that contains the new firmware file and select the file.
8. Click the **Open** button
9. If an Auth Code is required, enter the Auth Code in the **Auth Code** text box.
10. Click the **UPLOAD** button.

11.6 Updating the Firmware Using NovAtel Web UI

To use NovAtel Web UI to update the receiver firmware, the receiver must be connected to the device running Web UI using a Wi-Fi or Ethernet connection.

To update the firmware on the receiver:

1. Obtain the new firmware file.

See *Downloading Firmware Files* on page 127 for information about obtaining the latest version of receiver firmware.



Copy the firmware file to the device's local drive before uploading.

2. Use a Wi-Fi capable device (such as a laptop, tablet or smart phone) to connect to the receiver's Wi-Fi access point. The SSID and password for the receiver Wi-Fi are on a label on the receiver.
Alternately, connect the receiver to a computer using an Ethernet connection.
3. Open a web browser and enter any web address, for example, novatel.com (do not include "https").
4. Click or tap the Cog button.
5. Click or tap the Update button.
6. In the Firmware panel, click or tap the **CHOOSE FILE** button and navigate to the .shex file location and select the file.
7. If an Auth Code is also being applied, the Auth Code can be entered in the Auth Code field.
8. Click or tap the **UPLOAD** button. Once the upload is complete, Web UI automatically returns to the Main Window.

11.7 Updating Using SoftLoad Commands

Firmware can be updated on a running receiver using a process called SoftLoad. Any available communication ports on the receiver (COM, USB, ICOM, etc.) can be used. The SoftLoad process is made up of a set of commands and logs that are used to send new firmware data to a receiver and check the progress of the update. Use SoftLoad if automated loading is desired or if a connection is only possible through USB or Ethernet.

The receiver stops tracking GNSS satellites during the SoftLoad process. Do not attempt to SoftLoad when GNSS satellite tracking on the unit is required. If the unit is connected to the NovAtel Connect utility, only the Console and ASCII Message windows may remain open in the Connect Utility.

11.7.1 SoftLoad Commands and Logs

Refer to the [OEM7 Commands and Logs Reference Manual](#) for detailed log and command information.

Command	Description
SOFTLOADRESET	Initiate a new SoftLoad process
SOFTLOADSREC	Send an S-Record to the receiver for the SoftLoad process
SOFTLOADDATA	Send firmware image data to the receiver for the SoftLoad process
SOFTLOADCOMMIT	Complete the SoftLoad process
SOFTLOADSETUP	Send configuration information to the receiver for the SoftLoad process. This command is not required when working with a *.shex file

Log	Description
SOFTLOADSTATUS	Provides status updates for the ongoing SoftLoad process

Each command and log can be used in abbreviated ASCII, ASCII or binary format, with the exception of SOFTLOADDATA, which should only be used in binary format.

File Types

Firmware data is stored in *.shex files as ASCII data in the form of S-Records, based on the Motorola S-Record format. The *.shex file includes a digital signature for the firmware.

11.7.2 Working With S-Records

Each S-Record has a header indicating the type of information contained in the record.

Records beginning with S0, S5 and S7 contain metadata about the firmware image, such as version information and which card types are supported by the firmware image.

Example S0 Record

```
S0~V~OM7MR0400RN0000
```

Example S5 Records

```
S50000
```

```
S503D9FE25
```

```
S5033158D5A
```

Example S7 Records

```
S70000
```

```
S70500000000FA
```

Records beginning with S3 contain the actual firmware image data. Aside from the header, each pair of characters forms the ASCII representation of a binary byte. The format is as follows:

S3LL	AAAAAAAA	DDDDDDDD...DDDDDDDD	CC
			Check Sum
		Little Endian Data. These bytes are copied into the "data" field of the SOFTLOADDATA command	
	4 - Byte Address. Set this as the value of "offset" in the SOFTLOADDATA command		
	Length. This is the hexadecimal number of character pairs to follow in the record. This value minus 4 bytes for the address and 1 byte for the check sum is copied into the "data length" field of the SOFTLOADDATA command		
Header			

11.7.3 Sending Firmware Data

C++ source code is available to provide example code of processing S-Records and converting them to NovAtel format commands, as well as providing help with the SoftLoad process. Contact [NovAtel Customer Support](#) and ask about the srec2softload utility.

The **SOFTLOADSREC** and **SOFTLOADDATA** commands can be used to send firmware data from *.shex files to the receiver.

S0, S5 and S7 S-Records should be sent directly to the receiver using the **SOFTLOADSREC** command, by enclosing the S-Record in quotation marks and issuing the command to the receiver, as follows:

```
SOFTLOADSREC "<S-RECORD>"
```

S3 records can be sent individually to the receiver using the **SOFTLOADSREC** command. Alternatively, the data from an S3 record can be parsed and packaged together with data from other S3 records into a binary **SOFTLOADDATA** command. Packaging data parsed from multiple S3 records into a binary **SOFTLOADDATA** command can result in improved firmware update times as each S3 record contains only a small number of bytes of firmware data. A single **SOFTLOADDATA** command can package up to 4096 bytes of firmware data from multiple S3 records, whereas a single **SOFTLOADSREC** command contains a maximum of 28 bytes of firmware data from a single S3 record.

Multiple S3 records can be packaged into a single **SOFTLOADDATA** command as long as the data from one S3 record follows immediately after the previous record. That is, the address from the current S3 record must equal the address from the previous S3 record plus the data length of the previous S3 record. If the data is not consecutive then the **SOFTLOADDATA** command can be sent with the amount of data it has packaged up to that point. Subsequent data can be packaged in a new **SOFTLOADDATA** command. Within the **SOFTLOADDATA** command, the "offset" field remains the address of the first S3 record and the "data" and "data length" are updated to include the new data. Refer to the [OEM7 Commands and Logs Reference Manual](#) for command details.

The *.shex file data may contain many gaps and jumps. For example, in many NovAtel *.shex files, data for address 0x000_00000 is stored near the very end of the file.

Example Packaging Multiple S3 Records In A SOFTLOADDATA Command

Start a new **SOFTLOADDATA** command

```
S32100407AD48FCA63034B80F5CE0C36507DE3D8DCC0C6C0C00515D74BCACF2F2949E1
```

Address: 0x00407AD4 Num Data Bytes: 0x21 – 0x01 – 0x04 = 0x1C

```
S32100407AF04CCA4985F0F7B081E41D9B7D806C26989AE2D4E4CCBCB47C10FBFD3E43
```

Previous Address + Previous Num Bytes = 0x00407AD4 + 0x1C = 0x00407AF0

Address: 0x00407AF0 Num Data Bytes: 0x1C

Add data to existing **SOFTLOADDATA** command

```
S30D00407B0CDE0400A6374D5BFFC5
```

Previous Address + Previous Num Bytes = 0x00407AF0 + 0x1C = 0x00407B0C

Address: 0x00407B0C Num Data Bytes: 0x0D – 0x01 – 0x04 = 0x08

Add data to existing **SOFTLOADDATA** command

```
S3210000000007F0A7F1F4060000147B4000F49217813C7BB00014493F005C00000009
```

Previous Address + Previous Num Bytes = 0x00407B0C + 0x08 = 0x00407B14

Address: 0x00000000 Num Data Bytes: 0x1C

Requires new **SOFTLOADDATA** command because address does not match previous address + previous number of data bytes

Send existing **SOFTLOADDATA** command, and start a new **SOFTLOADDATA** command

```
S3210000001C80040000E001000030000000082B0100D8060000E4060000C806000063
```

Address: 0x0000001C Num Data Bytes: 0x1C

Previous Address + Previous Num Bytes = 0x00000000 + 0x1C = 0x0000001C

Add data to existing **SOFTLOADDATA** command

The **SOFTLOADDATA** command must be sent as a NovAtel binary format command.

11.7.4 SoftLoad Update Method

This section describes the sequence of commands that are issued to the receiver when updating using a *.shex file.



The response for each command must be processed before sending the next command so as to determine if the command was accepted or rejected, and to wait for the receiver to complete the operation.

Responses to SoftLoad commands are guaranteed to be output from the receiver within a specific time, which varies by command. Refer to specific SoftLoad command [OEM7 Commands and Logs Reference Manual](#) for more information on responses and the timeout values for SoftLoad commands.

1. Open a connection to any port on the receiver (COM, USB or ICOM) with the input and output INTERFACEMODE set to NOVATEL.
2. Request the SOFTLOADSTATUS log using the following command:

```
LOG SOFTLOADSTATUSA ONCHANGED
```
3. Initialize SoftLoad with a **SOFTLOADRESET** command. This command stops all tracking on the receiver to ensure sufficient memory is available for the loading process. An RXSTATUSEVENTA log reports a SoftLoad In Progress status.
4. Open the *.shex firmware file.
5. Read each line of the *.shex firmware file.
 - a. Send S0, S5 and S7 S-Records directly to the receiver using the **SOFTLOADSREC** command. The S-Record must be enclosed in quotation marks:

```
SOFTLOADSREC "<S-RECORD>"
```

 Data within S0 records can also be sent to the receiver by converting them to **SOFTLOADSETUP** commands. Refer to the **SOFTLOADSETUP** command in the [OEM7 Commands and Logs Reference](#)

[Manual](#) for details on how to convert from S0 S-Records to **SOFTLOADSETUP** commands.

- b. S3 S-Records should be parsed and packaged into a **SOFTLOADDATA** command.
6. Send the **SOFTLOADCOMMIT** command after all data from the *.shex file has been transferred to the receiver. The SOFTLOADSTATUS log reports the status of the loading process. Wait for a SOFTLOADSTATUS log to indicate the status is COMPLETE. The COMPLETE status or an error is guaranteed to be output from the receiver within 300 seconds from the time the **SOFTLOADCOMMIT** command was received by the receiver.
7. Send the auth code for the newly downloaded image using the **AUTH** command. This is only required if there is not already a signature auth code on the receiver as signature auth codes are maintained through a SoftLoad update. See *Authorization Code* on page 127 for details on Auth Codes.

```
AUTH ADD_DOWNLOAD <AUTH CODE>
```

8. Reset the receiver using any of the following methods:
 - Enter the **RESET** command
 - Enter the **FRESET** command
 - Power-cycle the receiver

Once the receiver resets, the new version of firmware is active.

The SoftLoad process can be safely canceled at any time using the **SOFTLOADRESET** command or by otherwise resetting the receiver. Once the COMPLETE status is reported by SOFTLOADSTATUS, the new firmware image will be run after the receiver is reset.

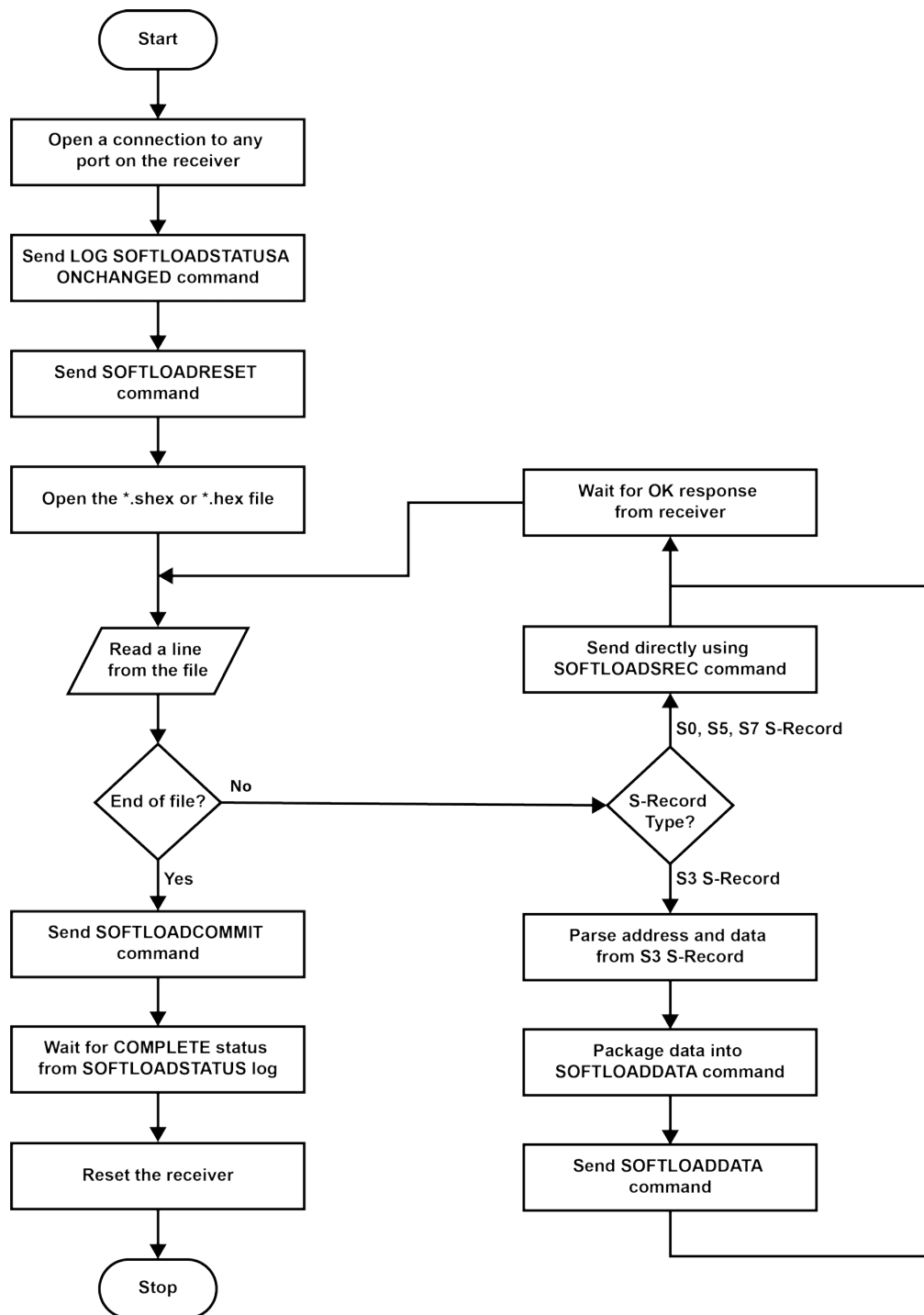

11.7.5 SoftLoad Errors

It is possible for errors to occur during the SoftLoad update. All command responses should be checked to verify all issued commands were accepted. The SoftLoad status should also be monitored in the SOFTLOADSTATUS log. Any status enum value greater than the ERROR status indicates an error has occurred during the SoftLoad update. In the event of an error, the SoftLoad update should be restarted by issuing a **SOFTLOADRESET** command or normal operation can be restored by resetting the receiver.

In rare cases after a SoftLoad error, the boot code may not be able to determine which is the latest firmware to be executed. To protect against this, SoftLoad does not erase the previous valid firmware image from flash on the

receiver. In such cases, the boot code will execute the old image and raise the "Safe Mode" error (see **RXSTATUS** log). If that error is detected, simply restart the SoftLoad process to reload the new firmware image and the error will be resolved.

11.8 Upgrading Using an Auth-Code

An authorization code (auth-code) enables (unlocks) model features.

An auth-code can be entered using NovAtel Connect, NovAtel Web UI or the command line interface.

11.8.1 Entering an Auth-Code Using NovAtel Connect

1. Obtain the new auth-code from NovAtel Sales or your local NovAtel dealer.
2. Connect a computer to the receiver using a serial (COM) cable, USB cable or Ethernet connection.
3. Start NovAtel Connect on the computer.
4. Use NovAtel Connect to connect to the receiver.

For information about using NovAtel Connect, refer to the help file in NovAtel Connect.

5. Click the **Firmware Update** button.

The Update window appears.

6. Enter the auth-code in the Auth Code text box.
7. Click the **Upload** button.

11.8.2 Entering an Auth-Code Using NovAtel Web UI

1. Obtain the new auth-code from NovAtel Sales or your local NovAtel dealer.
2. Use a Wi-Fi capable device (such as a laptop, tablet or smart phone) to connect to the receiver's Wi-Fi access point. The SSID and password for the receiver Wi-Fi are on a label on the receiver.
3. Open a web browser and enter any web address, for example, novatel.com (do not include "https").
4. Click or tap the Cog button.
5. Click or tap the Update button.
6. In the Firmware panel, enter the auth-code in the Auth Code field.
7. Click or tap the **UPLOAD** button. Once upload complete, Web UI automatically returns to the Main Window.

11.8.3 Entering an Auth-Code Using the Command Line

The **AUTH** command is used to enter an auth-code. The upgrade can be performed directly through the NovAtel Connect command line or from any other communications program.



Refer to *Format of Firmware Files* on page 128 for details on updating versus upgrading.

1. Power up the OEM7 receiver and establish communications.
2. Issue the **LOG VERSION** command to verify the current model, firmware version and serial number (refer to *Authorization Code* on page 127 for instructions on obtaining).
3. Issue the **AUTH** command, followed by the auth-code and model type (refer to *Authorization Code* on page 127 for details on obtaining any auth-code). The syntax is as follows:

```
auth <your auth-code here>
```

where **auth** is a command that enables model upgrades and auth-code is the upgrade authorization code, expressed as follows:

```
XXXXXX,XXXXXX,XXXXXX,XXXXXX,XXXXXX,MODEL,EXPDATE
```

where:

- Each X character is a case-insensitive ASCII character.
- The MODEL string is a maximum of 15 characters long and represents the model enabled by the auth-code.
- The EXPDATE string is the auth-code's expiry date, in YYMMDD format

Example:

```
auth 7WBMBK,887CB6,K5J3FH,5DF5P2,42PW8G,D1SB0GTT0,121211
```

When the **AUTH** command is executed, the OEM7 receiver reboots. Issuing the **LOG VERSION** command confirms the new upgrade model type and firmware version number.

If communicating using NovAtel Connect, the communication path must be closed and reopened using the Device menu.

APPENDIX A SPAN CPT7 Technical Specifications

Table 18: SPAN CPT7 Physical Description

Size	90 mm x 76 mm x 60 mm
Weight	500 grams
NovAtel Part Number	SPANCPT7NC-GSN-NNN-NNN SPANCPT7-GSN-NNN-NNN

See the following sections for more information about the SPAN CPT7:

- *SPAN CPT7 Performance Specifications* on the next page
- *SPAN CPT7 Mechanical Specifications* on page 143
- *SPAN CPT7 Electrical and Environmental Specifications* on page 146
- *SPAN CPT7 Data Communication Specifications* on page 148
- *SPAN CPT7 Strobe Specifications* on page 149
- *SPAN CPT7 Connectors* on page 150
- *SPAN CPT7 I/O1 Cable* on page 152
- *SPAN CPT7 I/O2 Cable* on page 154

A.1 SPAN CPT7 Performance Specifications

All specifications subject to GNSS system characteristics.

Table 19: SPAN CPT7 Receiver Performance

Position Accuracy ¹	Single point L1	1.5 m RMS
	Single point L1/L2	1.2 m RMS
	SBAS ²	60 cm RMS
	DGPS	40 cm RMS
	TerraStar-L ^{3,4}	40 cm RMS
	TerraStar-C PRO ^{3,4}	2.5 cm RMS
	RTK	1 cm + 1 ppm RMS
Signals Tracked Primary Antenna	GPS	L1 C/A, L1C, L2C, L2P, L5
	GLONASS	L1 C/A, L2 C/A, L2P, L3, L5 ⁵
	BeiDou	B1I, B1C, B2I, B2a
	Galileo	E1, E5 AltBOC, E5a, E5b
	NavIC (IRNSS)	L5
	QZSS	L1 C/A, L1C, L2C, L5
	SBAS	L1, L5
	L-Band	Up to 5 channels ⁶

¹Typical values. All position and velocity RMS values are based on Horizontal position accuracy. Performance specifications are subject to GNSS system characteristics, Signal-in-Space (SIS) operational degradation, ionospheric and tropospheric conditions, satellite geometry, baseline length, multipath effects and the presence of intentional or unintentional interference sources.

²GPS-only.

³Requires a TerraStar subscription which is available direct from NovAtel www.novatel.com/products/novatel-correct-ppp.

⁴Performance dependent on local observing conditions.

⁵Although hardware capable, GLONASS L5 is currently not available.

⁶Currently the receiver can track up to 3 L-Band channels.

Signals Tracked Secondary Antenna	GPS	L1 C/A, L1C, L2C, L2P, L5
	GLONASS	L1 C/A, L2 C/A, L2P, L3, L5
	BeiDou	B1I, B1C, B2I, B2a
	Galileo	E1, E5 AltBOC, E5a, E5b
	NavIC (IRNSS)	L5
	QZSS	L1 C/A, L1C, L2C, L5
Time to First Fix	Hot: <20 s (Almanac and recent ephemeris saved and approximate position and time entered) Cold: <39 s (No almanac or ephemeris and no approximate position or time)	
Signal Reacquisition	<0.5 s L1 (typical) <1.0 s L2 and L5 (typical)	
Data Rates	Measurements	up to 20 Hz
	Position	up to 20 Hz
	INS Position/Attitude	up to 200 Hz
	IMU Raw Data Rate	up to 100 Hz
Time Accuracy ¹	20 ns RMS	
Velocity Accuracy	<0.03 m/s RMS	

¹Time accuracy does not include biases due to RF or antenna delay.

Measurement Precision			Code	Carrier
	GPS	L1 C/A	4 cm	0.5 mm
		L2 P(Y)	8 cm	1.0 mm
		L2 C	8 cm	0.5 mm
		L5	3 cm	0.5 mm
	GLONASS	L1 C/A	8 cm	1.0 mm
		L2 P	8 cm	1.0 mm
		L2 C/A	8 cm	1.0 mm
	Galileo	E1	3 cm	0.5 mm
		E5a	3 cm	0.75 mm
		E5b	3 cm	0.75 mm
		E5 AltBOC	3 cm	0.75 mm
	BeiDou	B1I	4 cm	0.5 mm
		B1C	3 cm	0.5 mm
		B2I	4 cm	0.5 mm
		B2a	3 cm	0.5 mm
Velocity Limit ¹	515 m/s			

Table 20: SPAN CPT7 IMU Performance

Gyroscope Performance	
Technology	MEMS
Input Rate (max)	±200 °/second
Accelerometer Performance	
Technology	MEMS
Accelerometer Range	±20 g

¹Export licensing restricts operation to a maximum of 515 meters per second, message output impacted above 500 m/s.

A.2 SPAN CPT7 Mechanical Specifications

- *Figure 39: SPAN CPT7 Dimensions* on the next page
- *Figure 40: SPAN CPT7 Center of Navigation* on page 145



In the following diagrams, the dimensions are in millimeters.

Figure 39: SPAN CPT7 Dimensions

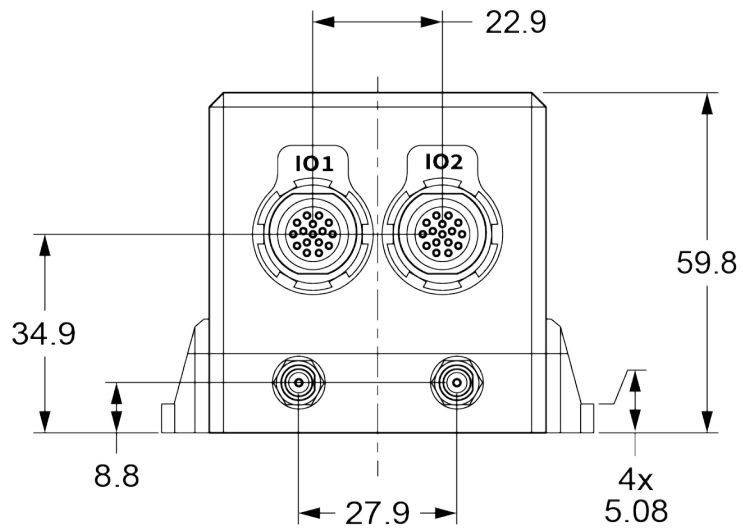
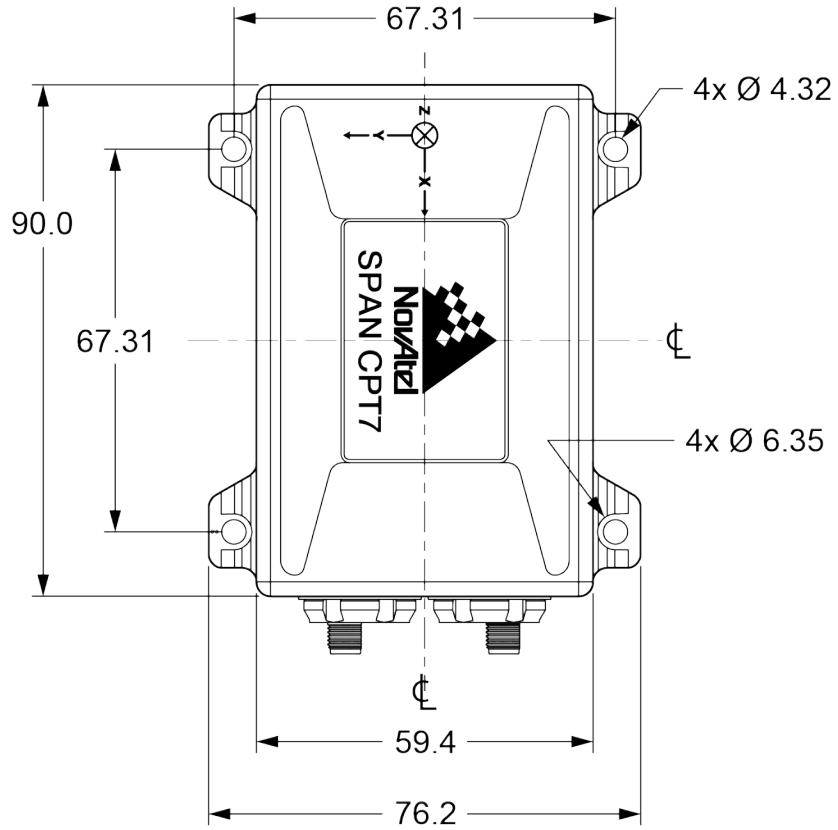
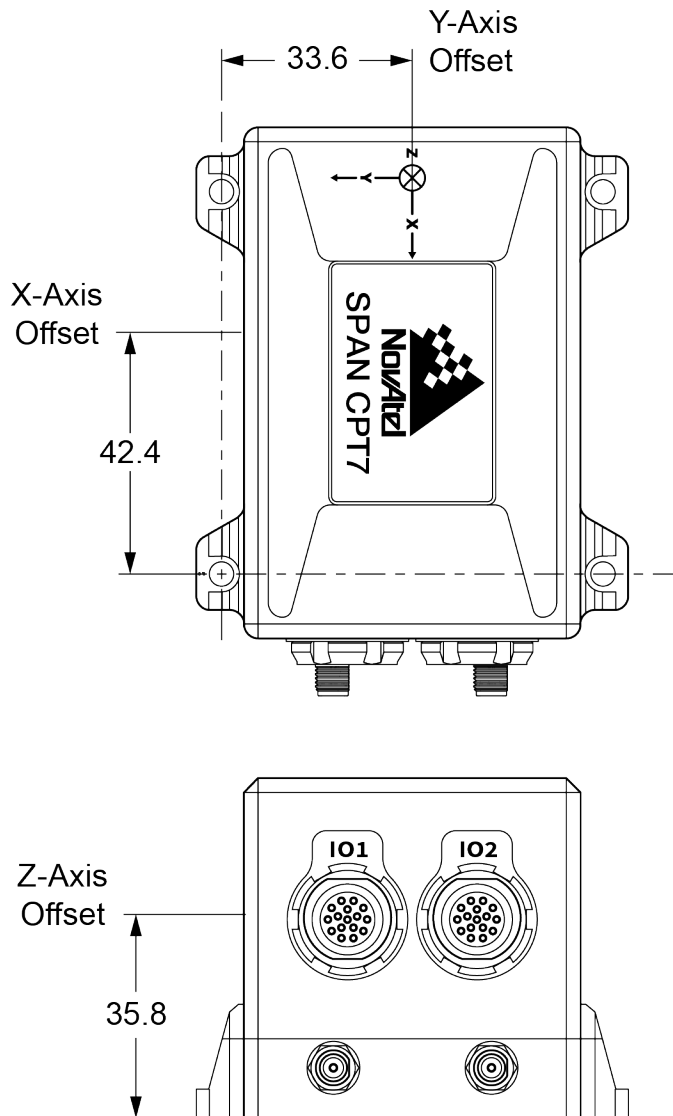

Figure 40: SPAN CPT7 Center of Navigation



The axis marking on the SPAN CPT7 indicates the orientation of the X, Y and Z axis only. It does not indicate the center of navigation. For the location of the center of navigation, refer to *Figure 40: SPAN CPT7 Center of Navigation* above.

A.3 SPAN CPT7 Electrical and Environmental Specifications

Table 21: SPAN CPT7 Environmental Specifications

Operating Temperature	-40°C to +71°C
Storage Temperature	-40°C to +85°C
Humidity	95% non-condensing
Submersion	2 m for 12 hours (IEC 60529 IPX8)
Water Resistance	MIL-STD-810G(Ch1), Method 512.6
Dust Resistance	MIL-STD-810G(Ch1), Method 510.6 IEC 60529 IP6X
Random Vibration	MIL-STD-810G(Ch1), Method 514.7, Category 24, 7.7 g RMS
Sinusoidal Vibration	IEC 60068-2-6
Bump	IEC 60068-2-27 Ea (25 g)
Shock – Operating	MIL-STD-810G(Ch1), Method 516.7, Procedure 1, 40 g, 11 ms terminal sawtooth
Acceleration	MIL-STD-810G(Ch1), Method 513.7, Procedure II (G Loading - 15 g)

Table 22: SPAN CPT7 Power Requirements

Voltage	+9 to +32 VDC
Power Consumption	7 W typical, all constellations, all frequencies, plus L-Band <div style="border: 1px solid black; padding: 5px; background-color: #f0f0f0;">  <p>These are typical values using serial ports without interference mitigation. These values can change with the number of satellites in view, firmware version, data logging rates and features in use. Use them as a guide for what you might expect but not as absolute values</p> </div>
Inrush Current	5 A for less than 1.3 ms (@ 5 V; typical)

Table 23: SPAN CPT7 RF Input/LNA Power Output

Antenna Connectors	SMA female, 50 Ω nominal impedance
--------------------	------------------------------------

Cascaded antenna LNA gain (before receiver)	Firmware 7.04 or later	HDR disabled	+15 dB to +55 dB, 26 dB typical
		HDR enabled	+20 dB to +55 dB, 30 dB typical
	Firmware before 7.04	HDR disabled	+15 dB to +40 dB, 26 dB typical
		HDR enabled	+20 dB to +40 dB, 30 dB typical
RF Input Frequencies	GPS L1:	1575.42 MHz	
	GPS L2:	1227.60 MHz	
	GPS L5:	1176.45 MHz	
	GLONASS L1:	1593-1610 MHz	
	GLONASS L2:	1237-1254 MHz	
	GLONASS L3:	1202.025 MHz	
	Galileo E1:	1575.42 MHz	
	Galileo E5a:	1176.45 MHz	
	Galileo E5b:	1207.14 MHz	
	Galileo E5:	1191.795 MHz	
	BeiDou B1I:	1561.098 MHz	
	BeiDou B1C:	1575.42 MHz	
	BeiDou B2I:	1207.14 MHz	
	BeiDou B2a	1176.45 MHz	
	L-Band:	1525 to 1560 MHz	
LNA Power	+5.0 VDC \pm 5%, 0 mA to 200 mA (supplied by receiver through center conductor of RF connector).		

A.4 SPAN CPT7 Data Communication Specifications

Table 24: Data Communications Interfaces

COM1	
Electrical format	RS-232
Data rates	2400, 4800, 9600 (default), 19200, 38400, 57600, 115200 or 230400 bit/s.
Signals supported	COM1_Tx, COM1_Rx
SPAN CPT7 port	IO2
Connector on Cable	DB9 female (on the SPAN CPT7 I/O2 Cable)
COM2	
Electrical format	RS-422
Data rates ¹	2400, 4800, 9600 (default), 19200, 38400, 57600, 115200, 230400 or 460800 bit/s.
Signals supported	COM2_Tx+, COM2_Tx-, COM2_Rx+, COM2_Rx-
SPAN CPT7 port	IO1
Connector on Cable	DB9 female (on SPAN CPT7 I/O1 Cable)
CAN Bus	
Electrical Format	ISO 11898-2
Data rates	1 Mbps maximum. CAN Bus throughput is determined by slowest device on the bus
SPAN CPT7 port	IO2
USB	
Electrical format	Conforms to USB 2.0
Data rates	Hi-speed (480 Mb/s)
SPAN CPT7 port	IO2
ETHERNET	
Physical layer	10BASE-T/100BASE-TX
SPAN CPT7 port	IO2

A.5 SPAN CPT7 Strobe Specifications

Table 25: SPAN CPT7 Strobes Description

Strobes	SPAN CPT7 Port	Input/Output	Factory Default	Comment
EVENT_IN1	IO1	Input Leading edge triggered	Active low	Input marks for which a pulse greater than 150 ns triggers certain logs to be generated. (Refer to the MARKPOS, MARK2POS, MARK1TIME and MARK2TIME logs and ONMARK trigger.) Polarity is configurable using the MARKCONTROL command.
EVENT_IN2	IO2			
EVENT_OUT1	IO1	Output	Active low	Programmable variable frequency outputs ranging from 0 Hz to 50 MHz (refer to the EVENTOUTCONTROL command). Note: EVENT_OUT1 can also be controlled by the FREQUENCYOUT command.
EVENT_OUT2	IO2			

Table 26: SPAN CPT7 Strobe Electrical Specifications

Strobe	Sym	Min (V)	Max (V)	Current (mA)
EVENT_IN1	V_{IL}	-	0.8	<±1 mA
EVENT_IN2	V_{IH}	2.0	3.3	
EVENT_OUT1	V_{OL}	-	0.4	±6 mA
EVENT_OUT2	V_{OH}	2.0	3.3	



All signal I/O are at LVCMOS levels.

A.6 SPAN CPT7 Connectors

The SPAN CPT7 has 2 Fischer Core 16 pin, circular connectors that provide access to the power and communication signals.

Figure 41: Fischer Core 16 Pin Connector

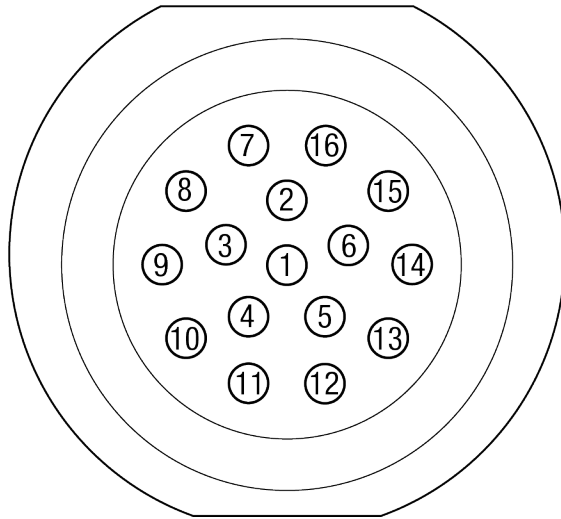

Table 27: IO1 Pin Out

Pin	Signal Name	Description
1	Reserved	Reserved
2	COM2_RX-	COM2 receive data negative. One half of the RS-422 receive differential pair.
3	Reserved	Reserved
4	Reserved	Reserved
5	Reserved	Reserved
6	COM2_TX-	COM2 transmit data negative. One half of the RS-422 transmit differential pair.
7	COM2_TX+	COM2 transmit data positive One half of the RS-422 transmit differential pair.
8	COM2_RX+	COM2 receive data positive One half of the RS-422 receive differential pair.
9	EVENT_OUT1	EVENT1 (Mark 1) output
10	EVENT_IN1	EVENT1 (Mark 1) input
11	Reserved	Reserved

Pin	Signal Name	Description
12	Reserved	Reserved
13	Reserved	Reserved
14	Reserved	Reserved
15	GND	Ground reference
16	VIN	Supply voltage input

Table 28: IO2 Pin Out

Pin	Signal Name	Description
1	Reserved	Reserved
2	ETH_RD+	Ethernet receive data positive One half of the Ethernet receive data differential pair.
3	CAN_H	CAN Bus port
4	USB_D+	One half of the USB differential pair.
5	Reserved	Reserved
6	ETH_TD-	Ethernet receive data negative One half of the Ethernet receive data differential pair.
7	ETH_TD+	Ethernet transmit data positive One half of the Ethernet transmit data differential pair.
8	ETH_RD-	Ethernet transmit data negative One half of the Ethernet transmit data differential pair.
9	EVENT_OUT2	EVENT2 (Mark2) output
10	EVENT_IN2	EVENT2 (Mark2) input
11	CAN_L	CAN Bus port
12	USB_D-	One half of the USB differential pair.
13	COM1_RX	COM1 receive data
14	COM1_TX	COM1 transmit data
15	GND	Ground reference
16	VIN	Supply voltage input

A.7 SPAN CPT7 I/O1 Cable

The NovAtel part number for the SPAN CPT7 I/O1 cable is 01020208. This cable provides access to all of the signals available on the IO1 connector of the SPAN CPT7.

Figure 42: SPAN CPT7 I/O1 Cable

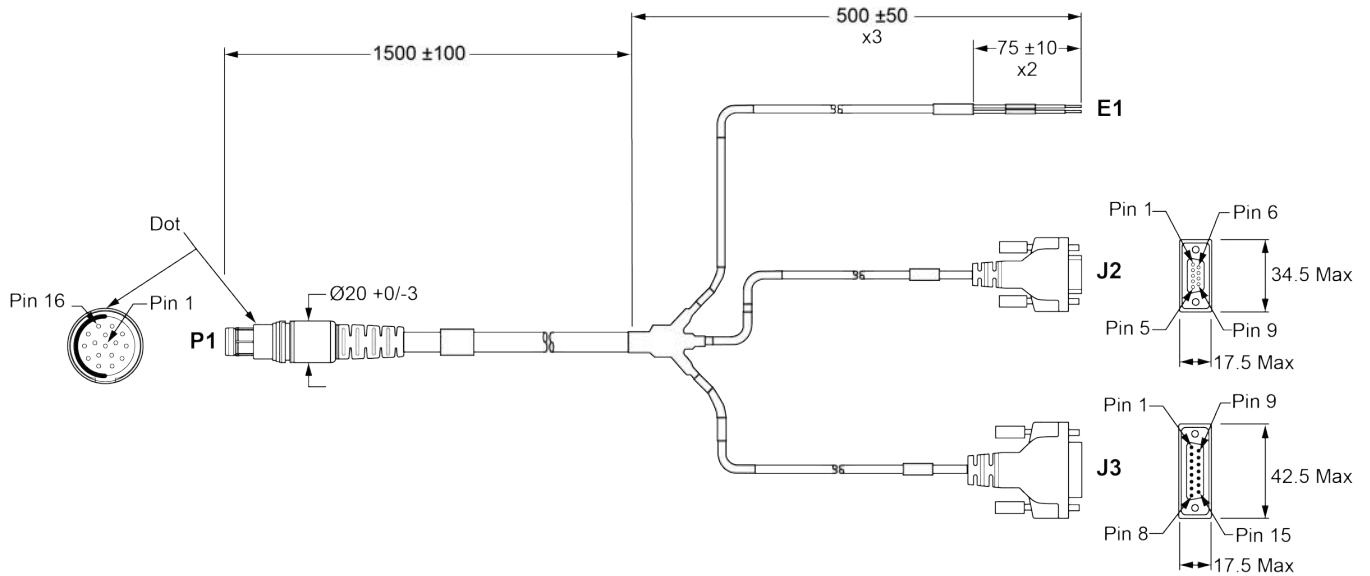

Table 29: SPAN CPT7 I/O1 Cable Pinout

P1 16 Pin Circular	Signal Name	J2 COM 2 DB9 Female	J3 AUX 1 DB15 Female	E1 Leads
1	Reserved		7	
2	COM2 RX-	7		
3	Reserved			
4	Reserved			
5	Data Ready		3	
6	COM2 TX-	8		
7	COM2 TX+	2		
8	COM2 RX+	3		
9	EVENT OUT1		10	
10	EVENT IN1		4	
11	Reserved			

P1 16 Pin Circular	Signal Name	J2 COM 2 DB9 Female	J3 AUX 1 DB15 Female	E1 Leads
12	Reserved			
13	Reserved			
14	Reserved			
15	GND	5	8	-VRTN
16	VIN			+VIN

A.7.1 Custom Cable Recommendations

To create a custom cable for the IO1 port, a specific connector is required on the SPAN CPT7 end of the cable. See the following table for information about this connector.

Table 30: I/O1 Connector

Connector	Description	Commercial Part Number	NovAtel Part Number
IO1	Fischer Core 16 pin cable mounted plug	SS 104 A086-140	21223365

A.8 SPAN CPT7 I/O2 Cable

The NovAtel part number for the SPAN CPT7 I/O2 cable is 01020209. This cable provides access to all of the signals available on the IO2 connector on the SPAN CPT7.

Figure 43: SPAN CPT7 I/O2 Cable

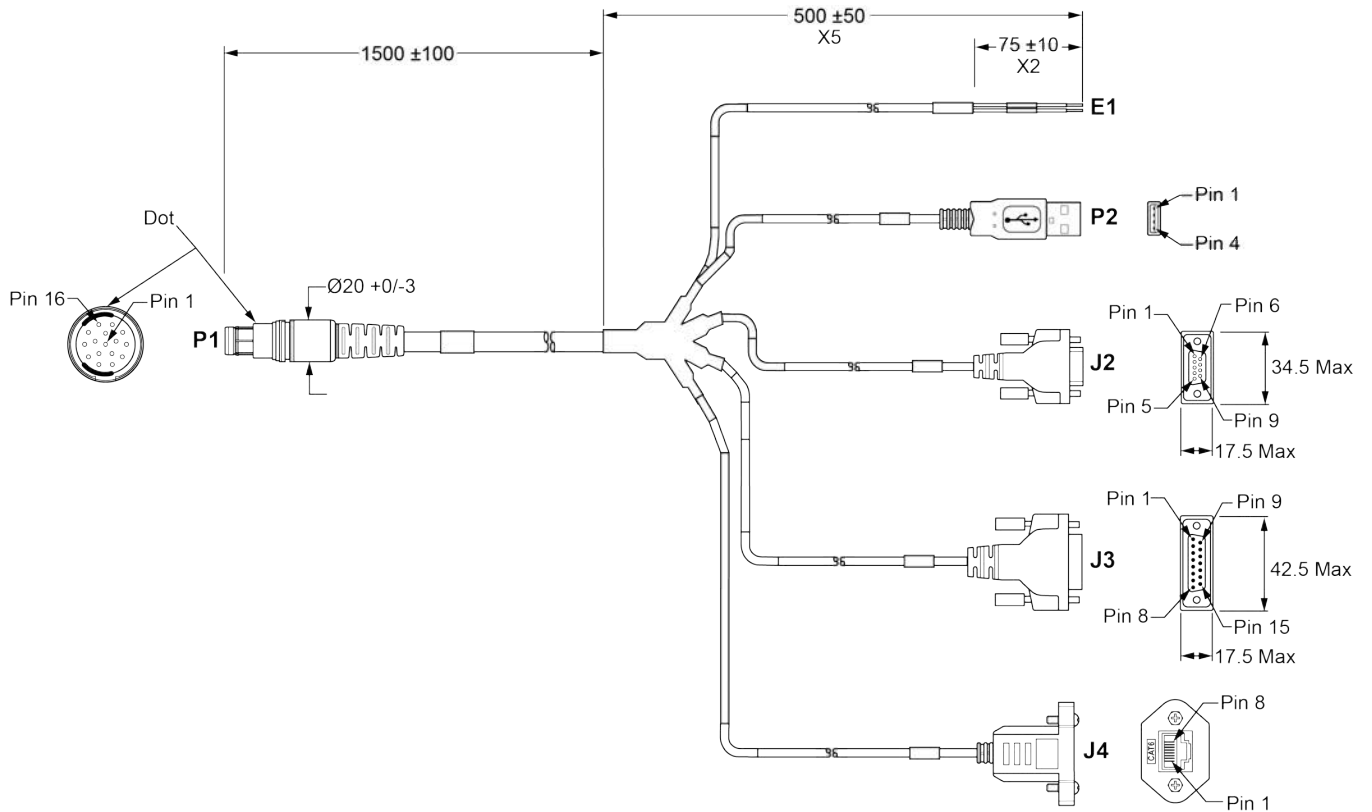

Table 31: SPAN CPT7 I/O2 Cable Pinout

P1 16 Pin Circular	Signal Name	P2 USB Type A Male	J2 COM 1 DB9 Female	J3 AUX 2 DB15 Female	J4 Ethernet RJ45 Female	Leads
1	Reserved A			14		
2	ETH_RX_H				3	
3	CAN_H			1		
4	USB+	3				
5	Reserved B			15		
6	ETH_TX_L				2	
7	ETH_TX_H				1	

P1 16 Pin Circular	Signal Name	P2 USB Type A Male	J2 COM 1 DB9 Female	J3 AUX 2 DB15 Female	J4 Ethernet RJ45 Female	Leads
8	ETH_RX_L				6	
9	EVENT_OUT2			9		
10	EVENT_IN2			6		
11	CAN_L			2		
12	USB-	2				
13	COM1_RXD		3			
14	COM1_TXD		2			
15	GND	4	5	8		-VRTN
16	+VIN					+VIN

A.8.1 Custom Cable Recommendations

To create a custom cable for the IO2 port, a specific connector is required on the SPAN CPT7 end of the cable. See the following table for information about this connector.

Table 32: IO2 Connector

Connector	Description	Commercial Part Number	NovAtel Part Number
IO2	Fischer Core 16 pin cable mounted plug	SS 104 A086-240	21223366

APPENDIX B Accessories and Replacement Parts

The following tables list the replacement parts available for your NovAtel OEM7 receiver. For assistance or to order additional components, contact your local NovAtel dealer or Customer Support.

Table 33: GNSS Antennas

NovAtel Part	Part Description
High Performance Antennas	
GNSS-501	GPS L1, GLONASS L1, BeiDou B1, Galileo E1 and L-Band
GNSS 502	GPS L1/L2, GLONASS L1/L2, BeiDou B1/B2, Galileo E1/E5b and L-Band
GNSS-802	GPS L1/L2, GLONASS L1/L2, BeiDou B1 and Galileo E1
GNSS-802L	GPS L1/L2, GLONASS L1/L2, BeiDou B1, Galileo E1 and L-Band
GNSS-804	GPS L1/L2, GLONASS L1/L2, BeiDou B1/B2 and Galileo E1/E5b
GNSS-804L	GPS L1/L2, GLONASS L1/L2, BeiDou B1/B2, Galileo E1/E5b and L-Band
GNSS-850	GPS L1/L2/L5, GLONASS L1/L2/L3, BeiDou B1/B2/B3, Galileo E1/E5a/E5b/E6 and L-Band
Compact Antennas	
GPS-301	3.5" circular form factor (GPS L1)
GPS-302-A	ARINC-743 bolt pattern (GPS L1/L2)
GPS-302L-A	ARINC-743 bolt pattern (GPS L1/L2, GLONASS L1 and L-Band)
GNSS-302L-A	ARINC-743 bolt pattern (GPS L1/L2, GLONASS L1/L2 and L-Band)
GNSS-303L	3.5" circular form factor (GPS L1/L2/L5, GLONASS L1/L2, BeiDou B1/B2/B3, Galileo E1/E5a/E5b/E6, NavIC L5 and L-Band)
GNSS-303L-A	ARINC-743 bolt pattern (GPS L1/L2/L5, GLONASS L1/L2, BeiDou B1/B2/B3, Galileo E1/E5a/E5b/E6, NavIC L5 and L-Band)

Table 34: SPAN CPT7 Cables

NovAtel Part	Part Description
01020208	SPAN CPT7 I/O1 Cable
01020209	SPAN CPT7 I/O2 Cable
21223365	Fischer Core Series cable mounted plug. For use on cables made for the SPAN CPT7 IO1 connector. Fischer part number: SS 104 A086-140

NovAtel Part	Part Description
21223366	Fischer Core Series cable mounted plug. For use on cables made for the SPAN CPT7 IO2 connector. Fischer part number: SS 104 A086-240

Table 35: GNSS Antenna Cables

NovAtel Part	Part Description
GPS-C006	5 meters – TNC to TNC cable
GPS-C016	15 meters – TNC to TNC cable
GPS-C032	30 meters – TNC to TNC cable
60723177	2.5 meters – SMA to TNC cable
60723178	5 meters – SMA to TNC cable

Table 36: SPAN CPT7 Mounting Accessories

NovAtel Part	Part Description
01020112	SPAN CPT7 Adapter Plate Kit

APPENDIX C Frequently Asked Questions

1. What is the minimum configuration I need to do to get the system running?
 - a. Specify the translational offset between the IMU center of navigation and the primary GNSS antenna phase center with the **SETINSTRANSULATION** command.
 - b. Specify the rotational offset between the IMU Body frame and the Vehicle frame, with the **SETINSROTATION** command.
2. Why don't I have any INS data?
 - a. By default, the raw IMU data begins flowing at system start up. If there is no INS data, check that the system has been configured properly.
 - b. If the **INSCOMMAND** command has been set to **START_FINE_TIME**, the RAWIMU logs are not available until the system has solved for time. This requires that an antenna is attached and satellites are visible to the system. You can verify that time is solved by checking the time status in the header of any standard header log such as BESTPOS. When the time status reaches FINETIME, the inertial filter starts and IMU data is available.
3. How can I access the inertial solution?

The GNSS+INS solution is available from a number of specific logs dedicated to the inertial filter. The **INSPOS** log, **INSPVA** log, **INSVEL** log, **INSSPD** log and **INSATT** log are the most commonly used logs for extracting the INS solution. These logs can be logged at any rate up to the rate of the IMU data (100 Hz). The solution can also be triggered by the mark input signal by requesting the **MARKxPVA** logs.

4. Can I still access the GNSS-only solution while running SPAN?

The GNSS only solution used when running the OEM7 receiver without the IMU is still available when running SPAN. Logs such as the **PSRPOS** log and **RTKPOS** log are still available. The **BESTGNSSPOS** log is also available to provide the best available GNSS only solution. Any non-INS logs should be logged at a maximum rate of 5 Hz when running SPAN. Only INS-specific logs should be logged at rates higher than 5 Hz when running SPAN.

5. What will happen to the INS solution when I lose GNSS satellite visibility?

When GNSS tracking is interrupted, the INS solution bridges through the gaps with what is referred to as free-inertial navigation. The IMU measurements are used to propagate the solution. Errors in the IMU measurements accumulate over time to degrade the solution accuracy. For example, after one minute of GNSS outage, the horizontal position accuracy is approximately 2.5 m when using an HG1700 AG58. The SPAN solution continues to be computed for as long as the GNSS outage lasts, but the solution uncertainty increases with time. This uncertainty can be monitored using the **INSSTDEV** log or **INSSTDEVS** log.



Further details on the command and logs in this section are available in the [OEM7 Commands and Logs Reference Manual](#).

APPENDIX D Importance of Antenna Selection

An antenna behaves both as a spatial and frequency filter, therefore, selecting the right GNSS antenna is critical for optimizing performance. An antenna must match the receiver's capabilities and specifications, as well as meet size, weight, environmental and mechanical specifications for the intended application.

Factors to consider when choosing a GNSS antenna include:

1. Constellation and signals

Each GNSS constellation and SBAS has its own signal frequencies and bandwidths. An antenna must cover the signal frequencies transmitted by the constellation and bandwidth supported by the GNSS receiver.

2. Antenna gain

Gain is a key performance indicator of a GNSS antenna. Gain can be defined as the relative measure of an antenna's ability to direct or concentrate radio frequency energy in a particular direction or pattern. A minimum gain is required to achieve a minimum carrier-to-power-noise ratio (C/No) to track GNSS satellites. The antenna gain is directly related to the overall C/No of the navigation GNSS receivers. Hence, antenna gain helps define the tracking ability of the system.

3. Element Gain

The element gain defines how efficient the antenna element is at receiving the signals. In any signal chain, you are only as good as the weakest link, so an antenna element with low element gain might be compensated by an increased low noise amplifier gain. However, the signal-to-noise ratio or C/No is still degraded.

4. Antenna beamwidth and gain roll-off

Gain roll-off is a factor of beamwidth, and specifies how much the gain changes over the elevation angle of the antenna. From the antenna's point of view, the satellites rise from the horizon towards zenith and fall back to the horizon. The variation in gain between zenith (directly overhead) and the horizon is known as the gain roll-off. Different antenna technologies have different gain roll-off characteristics.

5. Phase center stability

The phase center of the antenna is the point where the signals transmitted from satellites are collected. When a receiver reports a location fix, that location is essentially the phase center of the antenna.

The electrical phase center of any antenna will vary with the position of the transmitting signal it is receiving by as much as a few millimeters. As GNSS satellites move across the sky, the electrical phase center of the signal received will typically move with the satellite position unless the antenna has been carefully designed to minimize Phase Center Offset (PCO) and Phase Center Variation (PCV).

The PCO with respect to the Antenna Reference Point (ARP) is the difference between the mechanical center of antenna rotation and electrical phase center location. The PCO is also frequency dependent which means that there can be a different offset for each signal frequency. The PCV identifies how much the phase center moves with respect to the satellite elevation angles.

Figure 44: Plot of Good and Poor Antenna Phase Center Variation over Elevation Angle 0-90°

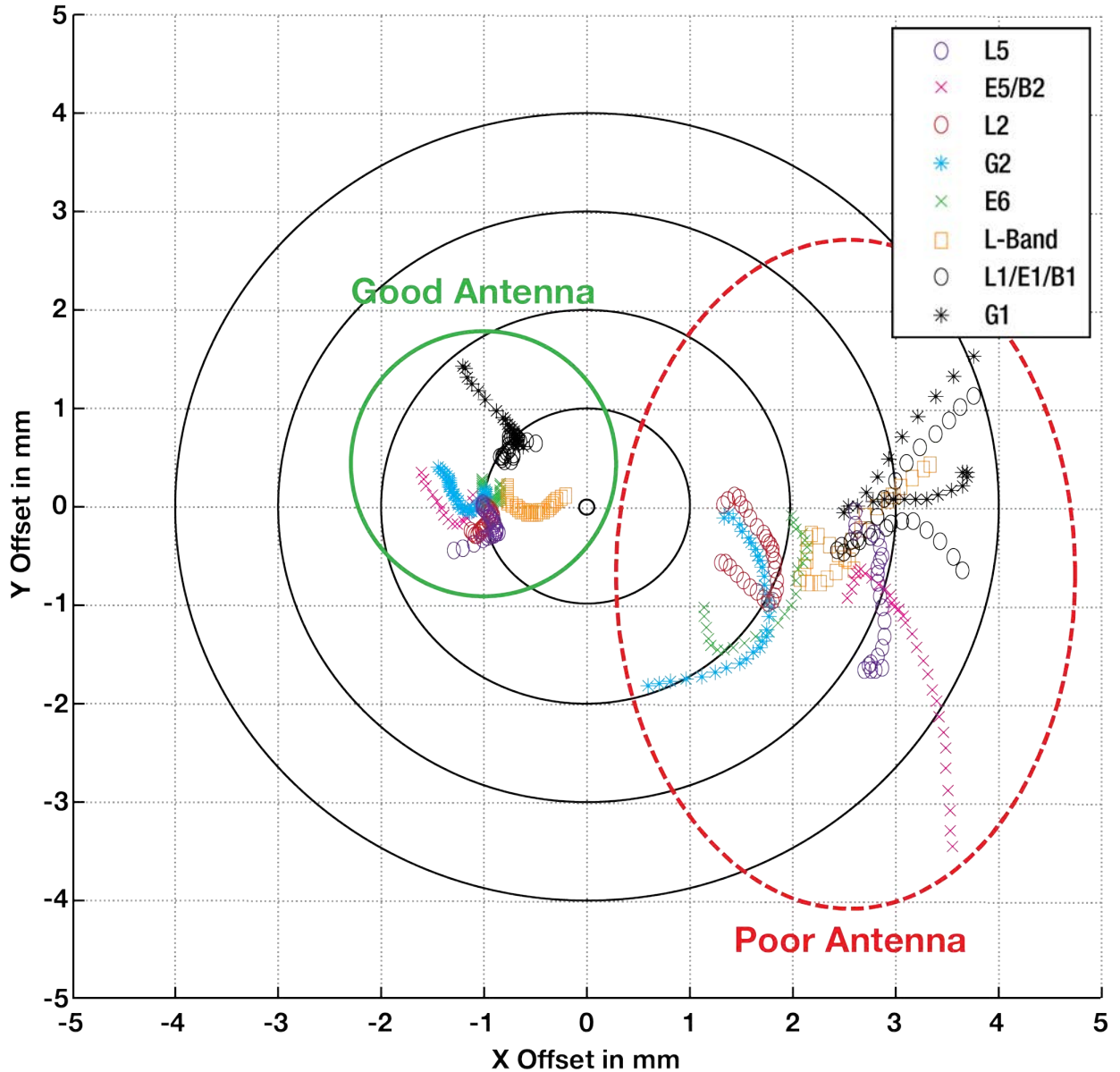

Many users can accept accuracies of less than a meter so these small phase center variations cause a negligible amount of position error. But if you require high precision, Real Time Kinematic (RTK) receivers can achieve position accuracies of 2-4 cm and a few millimeters of phase center error translates to a 10-15% error in reported position. For RTK survey applications, geodetic grade antennas offer superior PCO/PCV performance.

6. The application

An antenna has to meet the performance, environmental, mechanical, and operational requirements of the intended application. For example, GNSS antennas used for aviation applications should ideally be TSO/FAA certified and be rugged enough to handle extreme temperatures and vibration profiles. Survey rover antennas should be able to survive rough handling by surveyors including a pole drop.

The table below highlights some of the important desirable features needed for a GNSS antenna based upon the user's application.

Desirable Feature	Survey	GIS	Reference Station	Aviation/Aerial Survey	Marine	Construction/Mining	Precision Agriculture	Vehicle Tracking	Dock Operations	Unmanned Aircraft	Unmanned Vehicle	Timing
Low Profile				•		•		•		•		
Ultra-low PCO/PCV	•		•									
Low PCO/PCV		•		•		•	•			•	•	
High Vibration				•		•	•		•	•	•	
Rugged	•	•	•			•			•			
Single Frequency												•
Multi Constellation	•	•	•	•	•	•	•		•	•	•	
Multi Frequency (RTK)	•	•	•		•	•	•		•	•	•	
L-band frequency (Correction Services)					•		•					
Narrow Bandwidth												•
Weatherproof	•	•	•	•	•	•	•	•	•	•	•	•
Corrosion Resistant			•		•	•			•			•
High Multipath Suppression	•		•		•	•	•		•		•	
Pole Mount	•	•	•		•	•			•			•
Magnetic/Surface Mount						•	•	•	•		•	
TSO/FAA Certification				•						•		
Extended Temperature Range			•	•						•		
Small Form-factor/ Lightweight		•								•		
High Altitude Operation			•	•						•		

