



**SMART2
Installation and Operation
User Manual**

SMART2 Installation and Operation Manual

Publication Number: OM-20000185

Revision Level: v4

Revision Date: January 2021

Firmware Version: 7.08.01 / OA7CR0801RN0000

Warranty

NovAtel Inc. warrants that its GNSS products are free from defects in materials and workmanship, subject to the conditions set forth on our web site: novatel.com/products/novatel-warranty-and-return-policies and for the following time periods:

Return instructions

To return products, refer to the instructions found at: novatel.com/products/novatel-warranty-and-return-policies.

Proprietary Notice

Information in this document is subject to change without notice and does not represent a commitment on the part of NovAtel Inc. The software described in this document is furnished under a licence agreement or non-disclosure agreement. The software may be used or copied only in accordance with the terms of the agreement. It is against the law to copy the software on any medium except as specifically allowed in the license or non-disclosure agreement.

No part of this manual may be reproduced or transmitted in any form or by any means, electronic or mechanical, including photocopying and recording, for any purpose without the express written permission of a duly authorized representative of NovAtel Inc.

The information contained within this manual is believed to be true and correct at the time of publication.

GLIDE, NovAtel, NovAtel CORRECT, OEM7, RELAY and TerraStar are trademarks of NovAtel, Inc., entities within the Hexagon Autonomy & Positioning division, their affiliated entities, and/or their licensors. All other trademarks are properties of their respective owners.

© Copyright 2021 NovAtel Inc. All rights reserved. Unpublished rights reserved under International copyright laws.

Table of Contents

SMART2 Notices

Customer Support

Chapter 1 SMART2 Overview

1.1 Features and Models	13
1.2 SMART2 Connector Overview	13
1.3 SMART2 LED	14
1.4 Related Documents and Information	15

Chapter 2 SMART2 Installation

2.1 Mounting and Orientating the SMART2	16
2.1.1 Mounting Plate	17
2.2 Connect the SMART2 to Data Communication Equipment	18
2.2.1 Serial Ports	18
2.2.2 CAN Bus Port	19
2.2.3 Bluetooth	19
2.3 Connect I/O Signals to a SMART2	19
2.4 Connect Power to the SMART2	19
2.4.1 Fuse for the Power Supply	20
2.4.2 Power Supply Requirements for the SMART2	20
2.5 Check that the SMART Antenna is Working	21
2.6 SMART Antenna Additional Equipment Required	21

Chapter 3 SMART2 Operation

3.1 Communications with the Receiver	23
3.1.1 Serial Port Communications	23
3.1.2 CAN Bus Communications	24
3.1.3 Bluetooth® Communications	24
3.2 Getting Started	25
3.2.1 Communicating with the Receiver	25
3.3 GLIDE	26
3.3.1 Dual-Frequency GLIDE	26
3.3.2 PDP and GLIDE Configurations	26
3.4 Enabling SBAS Positioning	27
3.5 Enabling PPP	27
3.5.1 TerraStar Subscriptions	27
3.6 Terrain Compensation	28
3.6.1 Configuring Terrain Compensation	30
3.6.2 Configuring Terrain Compensation using a NMEA Command	34
3.7 SMART Antenna Emulated Radar	35
3.7.1 Emulated Radar (ER)	35
3.8 Logging Using NovAtel Application Suite or Setup & Monitor (Web)	35

Chapter 4 SMART2 CAN Bus

4.1	Default Configuration	36
4.2	Configuring the CAN Bus	37
4.2.1	Configuration Notes	37
4.2.2	Example of Enabling the CAN Bus	37
4.2.3	Example of Modifying the CAN Bus Parameters	38
4.2.4	Example of Detecting an Address Claim Failure and Reconfiguring	38
4.2.5	Address Claim Procedure	38
4.3	SMART2 NMEA2000 Logging	39
4.3.1	How to Configure CAN1 to Transmit NMEA2000 Messages	39

Chapter 5 Built-In Status Tests

5.1	RXSTATUSEVENT Log	40
5.2	RXSTATUS Log	40
5.2.1	Status Word	40
5.2.2	Error Word	41
5.2.3	Status Code Arrays	41
5.2.4	Receiver Status Code	42
5.2.5	Auxiliary Status Codes	42
5.2.6	Set and Clear Mask for all Status Code Arrays	42

Chapter 6 Troubleshooting

6.1	Examining the RXSTATUS Log	44
6.2	Examining the AUX1 Status Word	47
6.3	High Temperature Environments	48
6.3.1	Indicators of an Error State	48
6.3.2	Recovering from a Temperature Status Error	48
6.3.3	Mitigating High Receiver Temperature	48
6.3.4	Monitoring the Receiver Temperature	48
6.4	Safe Mode	49
6.4.1	Reset Loop Detection	50
6.4.2	Recovery Steps	50

Chapter 7 NovAtel Firmware and Software

7.1	Firmware Updates and Model Upgrades	51
7.1.1	Firmware Updates	51
7.1.2	Model Upgrades	51
7.2	Authorization Code	51
7.3	Downloading Firmware Files	52
7.3.1	Format of Firmware Files	52
7.4	Updating or Upgrading Using the WinLoad Utility	53
7.4.1	Using the WinLoad Utility	53
7.5	Updating the Firmware Using NovAtel Application Suite	55
7.6	Updating Using SoftLoad Commands	56
7.6.1	SoftLoad Commands and Logs	56
7.6.2	Working With S-Records	56

7.6.3	Sending Firmware Data	57
7.6.4	SoftLoad Update Method	58
7.6.5	SoftLoad Errors	60
7.7	Upgrading Using an Auth-Code	61
7.7.1	Entering an Auth-Code Using NovAtel Application Suite	61
7.7.2	Entering an Auth-Code Using the Command Line	61

APPENDIX A SMART2 Technical Specifications

A.1	SMART2 Performance Specifications	64
A.2	SMART2 Mechanical Specifications	66
A.3	SMART2 Environmental and Electrical Specifications	69
A.4	SMART2 Data Communication Specifications	70
A.5	SMART2 Strobe Specifications	71
A.6	SMART Antenna Interface Cable (Optional Accessory)	72
A.6.1	SMART Antenna Custom Cable Recommendation	73

APPENDIX B SMART2 Accessories and Replacement Parts

SMART2 Notices

The following notices apply to the SMART2 devices (model dependent).



Changes or modifications to this equipment, not expressly approved by NovAtel Inc., could void the user's authority to operate this equipment.

FCC

This device complies with part 15 of the FCC Rules. Operation is subject to the following two conditions: (1) this device may not cause harmful interference, and (2) this device must accept any interference received, including interference that may cause undesired operation.

SMART2 has been tested and found to comply with the radiated and conducted emission limits for a Class B digital device. The Class B limits are designed to provide reasonable protection against harmful interference in a residential installation.

The equipment listed generates, uses and can radiate radio frequency energy and, if not installed and used in accordance with the instructions, may cause harmful interference to radio communications. However, there is no guarantee that interference will not occur in a particular installation. If this equipment does cause harmful interference to radio or television reception, which can be determined by turning the equipment off and on, the user is encouraged to try to correct the interference by one or more of the following measures:

- Re-orient or relocate the SMART2
- Increase the separation between the equipment and the SMART2
- Connect the equipment to an outlet on a circuit different from that to which the SMART2 is connected
- Consult the dealer or an experienced Radio/TV technician for help



The SMART2 has been authorized for use in Mobile applications. At least 20 cm (8 inches) of separation between the SMART2 and the User must be maintained at all times.

Bluetooth

SMART2-B and SMART2-TB contain a Bluetooth radio with the following approvals:

- FCC ID: QQQBT121

Innovation, Science and Economic Development (ISED) Canada

SMART2 Class B digital device complies with Canadian ICES-003.

SMART2 appareil numérique de la classe B est conforme à la norme NMB-003 du Canada.

This device complies with ISED license-exempt RSS-GEN and RSS-247. Operation is subject to the following two conditions: (1) this device may not cause interference and (2) this device must accept any interference, including interference that may cause undesired operation of the device.

Cet appareil est conforme à la norme ISED RSS-GEN et RSS-247. Son fonctionnement est soumis aux deux conditions suivantes: (1) cet appareil ne doit pas provoquer d'interférences et (2) cet appareil doit accepter toute interférence, y compris les interférences pouvant entraîner un fonctionnement indésirable de l'appareil.



The SMART2 has been authorized for use in Mobile applications. At least 20 cm (8 inches) of separation between the SMART2 and the User must be maintained at all times.

Le SMART2 a été autorisé pour une utilisation dans les applications mobiles. Au moins 20 cm (8 pouces) de séparation entre le SMART2 et l'utilisateur doit être maintenue à tous fois.

Bluetooth

SMART2-B and SMART2-TB contain a Bluetooth radio with the following approvals:

- IC: 5123A-BGTBT121

European Union (EU) SMART2-B and SMART2-TB Bluetooth

NovAtel Inc. declares that the SMART2-B and SMART2-TB Bluetooth transceivers are in compliance with Directive 2014/53/EU (Radio Equipment).

The full text of the EU Declaration of Conformity may be obtained from the NovAtel web site at:

novatel.com/products/novatel-compliance/eu-declaration-of-conformity

Radio Information

Description of Service: Bluetooth - BR/EDR/BLE

Operational Frequency: 2400 MHz to 2480 MHz

Modulation: GFSK/4-DQPSK/8-DPSK

Rated Power: 13.0 dBm e.i.r.p

RoHS

The SMART2 is in conformity with Directive 2011/65/EU of the European Parliament and of the council of 8 June 2011 on the restriction of the use of certain hazardous substances in electrical and electronic equipment.

WEEE Notice

If you purchased your SMART2 product in Europe, please return it to your dealer or supplier at the end of its life. The objectives of the European Community's environment policy are, in particular, to preserve, protect and improve the quality of the environment, protect human health and utilise natural resources prudently and rationally. Sustainable development advocates the reduction of wasteful consumption of natural resources and the prevention of pollution. Waste electrical and electronic equipment (WEEE) is a regulated area. Where the generation of waste cannot be avoided, it should be reused or recovered for its material or energy. WEEE

products may be recognized by their wheeled bin label ()

See novatel.com/products/novatel-compliance/novatel-environmental-compliance for more information.

E-Mark

The SMART2 has been granted EC type approval of an electric/electronic subassembly with respect to electromagnetic compatibility ECE Regulation 10.05. Therefore the equipment is labeled with the following approval marks.



10 R - 05 10669

SMART2 International Type Approval

Australia and New Zealand



Brazil



04841-18-03402

Eurasian Economic Community

Armenia, Belarus, Kazakhstan, Kyrgyzstan and Russia



Japan



Korea



Serbia



V005 19

Ukraine



Uruguay

Contiene módulo : BT121

Customer Support

NovAtel Knowledge Base

If you have a technical issue, visit the NovAtel Support page at novatel.com/support. Through the *Support* page, you can contact Customer Support, find papers and tutorials or download the latest firmware. To access the latest user documentation, visit docs.novatel.com/OEM7.

Before Contacting Customer Support

Before contacting NovAtel Customer Support about a software problem, perform the following steps:



If logging data over an RS-232 serial cable, ensure that the configured baud rate can support the data bandwidth (see **SERIALCONFIG** command). NovAtel recommends a minimum suggested baud rate of 230400 bps.

1. Log the data suggested in the appropriate *Troubleshooting Logs* section to a file on your computer for 15 minutes.
 - *General Troubleshooting Logs* on the next page
 - *Tracking and Interference Troubleshooting Logs* on the next page
 - *PPP Troubleshooting Logs* on page 12
2. Send the data file to NovAtel Customer Support: support.novatel@hexagon.com
3. You can also issue a **FRESET** command to the receiver to clear any unknown settings.



The **FRESET** command will erase all user settings. You should know your configuration (by requesting the RXCONFIGA log) and be able to reconfigure the receiver before you send the **FRESET** command.

If you are having a hardware problem, send a list of the troubleshooting steps taken and the results.

Contact Information

Log a support request with NovAtel Customer Support using one of the following methods:

Log a Case and Search Knowledge:

Website: novatel.com/support

Log a Case, Search Knowledge and View Your Case History: (login access required)

Web Portal: <https://novatelsupport.force.com/community/login>

E-mail:

support.novatel@hexagon.com

Telephone:

U.S. and Canada: 1-800-NOVATEL (1-800-668-2835)

International: +1-403-295-4900

General Troubleshooting Logs

```
LOG RXSTATUSB ONCHANGED
LOG RAWEPHEMB ONNEW
LOG GLORAWEPHEMB ONNEW
LOG BESTPOSB ONTIME 1
LOG RANGE B ONTIME 1
LOG RXCONFIGA ONCE
LOG VERSIONA ONCE
LOG LOGLISTA ONCE
LOG PORTSTATSA ONTIME 10
LOG PROFILEINFOA ONCE
LOG HWMONITORA ONTIME 10
```

Tracking and Interference Troubleshooting Logs

```
LOG VERSIONA ONCE
LOG RXCONFIGA ONCE
LOG CHANCONFIGLISTB ONCE
LOG PASSTHROUGH A ONNEW
LOG RXSTATUSB ONCHANGED
LOG CLOCKSTEERINGB ONCHANGED
LOG RAWEPHEMB ONNEW
LOG GLORAWEPHEMB ONNEW
LOG GALINAVRAWEPHEMERISB ONNEW
LOG BDSEPEHEMERISB ONNEW
LOG QZSSEPEHEMERISB ONNEW
LOG NAVICEPEHEMERISB ONNEW
LOG RAWALMB ONNEW
LOG GLORAWALMB ONNEW
LOG GALALMANACB ONNEW
LOG BDSALMANACB ONNEW
LOG QZSSALMANACB ONNEW
LOG NAVICALMANACB ONNEW
LOG IONUTCB ONNEW
LOG GLOCLOCKB ONNEW
LOG GALCLOCKB ONNEW
LOG BDSLOCKB ONNEW
LOG TRACKSTATB ONTIME 1
LOG RANGE B ONTIME 1
LOG BESTPOSB ONTIME 1
LOG SATVIS2B ONTIME 30
LOG ITDETECTSTATUSB ONCHANGED
```

For dual antenna receivers, add these logs:

```
LOG TRACKSTATB_1 ONTIME 1
LOG RANGE _1 ONTIME 1
```

For interference issues add this log.

```
LOG ITPSDDETECTB ONNEW
```

For interference issues, when you have enough datalink bandwidth to handle large logs, add this log:

```
LOG ITPSDFINALB ONNEW
```

PPP Troubleshooting Logs

```
LOG RXSTATUSB ONCHANGED
LOG RAWEPHEMB ONNEW
LOG GLORAWEPHEMB ONNEW
LOG QZSSRAWEPHEMB ONNEW
LOG BDSRAWNAVSUBFRAMEB ONNEW
LOG GALFNAVRAWEPHEMERISB ONNEW
LOG GALINAVRAWEPHEMERISB ONNEW
LOG RANGE B ONTIME 1.0
LOG BESTPOSB ONTIME 1.0
LOG RXCONFIGB ONCE
LOG VERSIONB ONCE
LOG TRACKSTATB ONTIME 1.0
LOG LBANDTRACKSTATB ONTIME 1.0
LOG PPPPOSB ONTIME 1.0
LOG PPPSATSB ONTIME 1.0
LOG TERRASTARINFOB ONCHANGED
LOG TERRASTARSTATUSB ONCHANGED
LOG PSRPOSB ONTIME 1.0
LOG ALMANACB ONNEW
LOG IONUTCB ONNEW
LOG GLORAWALMB ONNEW
LOG GLOCLOCKB ONNEW
LOG LBANDBEAMTABLEB ONCHANGED
```

Chapter 1 SMART2 Overview

The SMART2 is a high performance GNSS receiver and antenna, capable of receiving and tracking different combinations of GNSS code and carrier signals on a maximum of 167 channels. SBAS (Satellite Based Augmentation Systems) support, which includes WAAS (North America), EGNOS (Europe) and MSAS (Japan) is standard. Refer to *An Introduction to GNSS* available on our website at novatel.com/an-introduction-to-gnss for an overview of each of the above signal types. The SMART2 rear panel also features a Light Emitting Diode (LED) for status indication.

Once properly powered, the SMART2 begins operating as a fully functional GNSS system.

1.1 Features and Models

The main features of the SMART2 include:

- a high performance, dual-frequency GNSS receiver
- a high performance GNSS dual-frequency antenna
- a CAN port
- three RS-232 COM ports
- Bluetooth wireless technology (optional)
- one LED status indicator
- a PPS output
- a Mark Input (MKI) (Event1)
- a water and dust tight enclosure
- Emulated Radar output
- Terrain Compensation (optional)
- support for TerraStar-L and TerraStar-C PRO correction services

The SMART2 is available in several different firmware models whose configurations may include other additional features (see *Table 1: Hardware Options* below).

Table 1: Hardware Options

Tradename	Description
SMART2	SMART2
SMART2-B	SMART2 with Bluetooth
SMART2-TB	SMART2 with Bluetooth and Terrain Compensation

Contact NovAtel Sales at novatel.com/contactus/sales-offices for information regarding available models, upgrading a model to increase feature/functionality or go to novatel.com/products/smart-antennas/smart2. Refer to the chapter *Firmware Updates and Model Upgrades* on page 51 for details.

1.2 SMART2 Connector Overview

All SMART2 models use the same connector for power and communication. Refer to *Table 2: SMART2 Connector Pin-out* on the next page for pin outs.

Figure 1: SMART2 Interface Connector

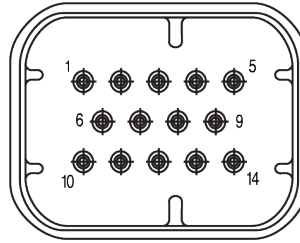

Table 2: SMART2 Connector Pin-out

Pin	Use	Pin	Use
1	COM1 TxD	8	COM3 TxD
2	COM1 RxD	9	Power Negative/Return
3	COM2 TxD	10	ER_OUT (Emulated Radar Output)
4	COM2 RxD	11	MKI (Mark Input)
5	Signal Ground (COM/MKI/PPS/ER)	12	PPS (Pulse Per Second) Output
6	CAN+	13	COM3 RxD
7	CAN-	14	Power Positive/Source

1.3 SMART2 LED

The SMART2 has a single LED to indicate status.

Figure 2: SMART2 Status LED

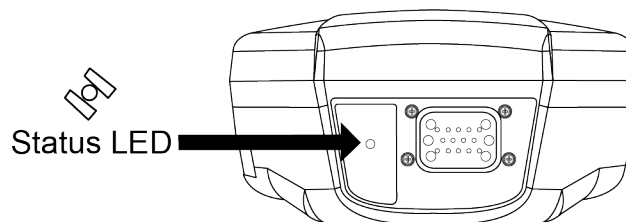

Table 3: SMART2 Status Indicator

Label	Description	Model
	Status (Power/GNSS)	All hardware options

Table 4: SMART2 Status LED

State	Description
Green Solid	Precise solution good (PPP, Fixed or PPP+INS)
Green Slow Flash (1 Hz)	Precise solution converging
Yellow Solid	Basic solution (Single Point/SBAS/DGPS)
Yellow Slow Flash (1 Hz)	Tracking satellites and calculating initial position solution
Yellow Fast Flash (3 Hz)	Initialized and ready for communication
Red Solid (Initial)	Power On/Reset (for about 10 seconds after power-on or reset)
Red Solid (Continuous)	Receiver system error, if indicator persists after 30 seconds
Red Slow Flash (1 Hz)	Position quality warning (unreliable/high error)
Red Fast Flash (3 Hz)	Position unavailable (unusable)

1.4 Related Documents and Information

After the receiver is set up, the [Agriculture Commands and Logs Reference Manual](#) becomes the primary source for command and log information.



Each receiver has a specific set of features, so some commands and logs may not be supported by your model.

This manual does not cover receiver service and repair. Contact a local NovAtel dealer for service or repair inquiries (refer to *Customer Support* on page 10 for contact details).

Chapter 2 SMART2 Installation

When the appropriate equipment is selected, complete the following steps to set up and begin using the SMART2.

Figure 3: SMART2 Installation

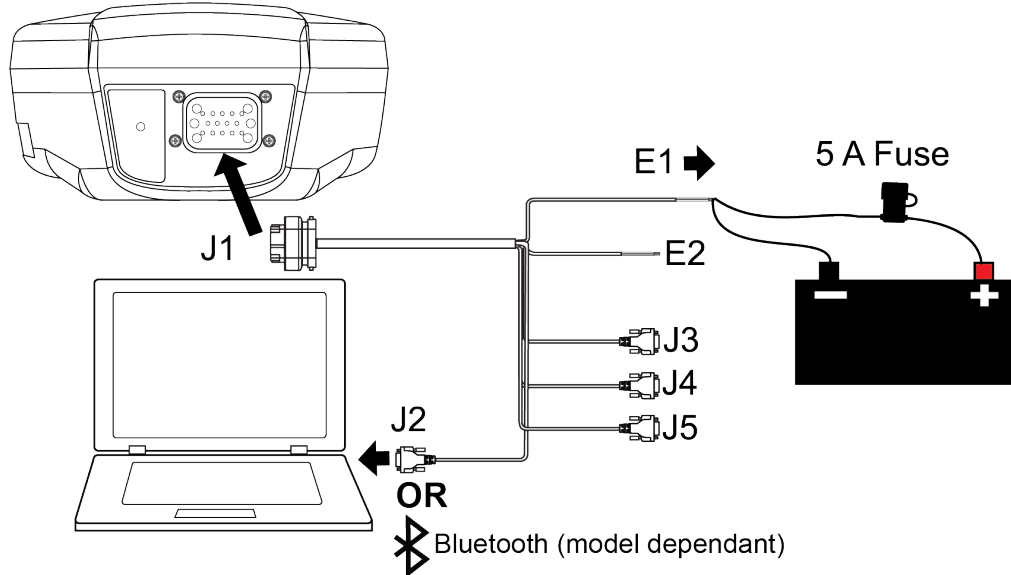

1. Mount the SMART2 receiver. Refer to *Mounting and Orientating the SMART2* below for mounting details.
2. Connect the NovAtel interface cable, or custom wiring harness, to the COM and Power port on the back of the SMART2 (J1). Refer to *SMART2 Connector Overview* on page 13 for details of the connector. Refer to *SMART Antenna Interface Cable (Optional Accessory)* on page 72 for cable details.
3. Connect other GNSS system components using the output lines.
4. Connect the SMART2 to other GNSS system components, such as a computer or data terminal, using the communication ports.
See *Connect the SMART2 to Data Communication Equipment* on page 18.
5. Connect the power leads on the interface cable to the power supply.
Ensure a 5 A slow blow fuse is incorporated in the power wiring. Refer to *SMART Antenna Interface Cable (Optional Accessory)* on page 72 and *SMART Antenna Additional Equipment Required* on page 21 for fuse recommendations.
See *Connect Power to the SMART2* on page 19 and *Power Supply Requirements for the SMART2* on page 20 for details.

Refer to *SMART2 LED* on page 14 for details of SMART2 LED states.

2.1 Mounting and Orientating the SMART2

Mount the SMART2 on a secure, stable structure capable of safe operation in the specific environment.

- When installing on a vehicle, mount the SMART2 on the vehicle roof, ideally close to the pivot point of the vehicle. The SMART2 must be mounted with the connector facing the rear of the vehicle.



The SMART2 must be rigidly secured to the vehicle to avoid errors caused by vibration and motion.

- If installing in a stationary location, mount the SMART2 in a location that has a clear view of the sky so that each satellite above the horizon can be tracked without obstruction.

Figure 4: Orienting SMART2

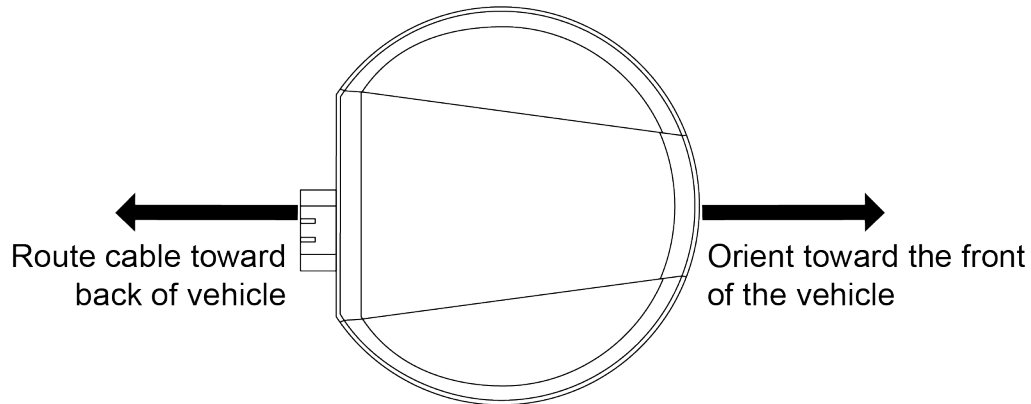

The SMART2 can be mounted to the vehicle using the integrated magnets, an optional mounting plate or four M4 screws.



The optimal screw penetration into the SMART2 mounting holes is 6 mm (± 1 mm) deep. When selecting screws for mounting the SMART2, ensure the screw penetration does not exceed this specification. Using excessively long screws can damage the SMART2 enclosure.

2.1.1 Mounting Plate

Two mounting plates are available to facilitate mounting the receiver:

- a surface mounting plate
- a pole mounting plate

Refer to *SMART2 Mechanical Specifications* on page 66 for mounting plate and pole mounting dimensions.

Surface Mounting Plate

To install the surface mounting plate:

1. Place the SMART2 on the surface mounting plate. The alignment pins on the mounting plate seat in the two of the SMART2 mounting holes.
2. The integrated magnets will hold the SMART2 on to the mounting plate.
To secure the SMART2 to the mounting plate, use two M4 screws that pass through the mounting plate and into the SMART2. Torque the screws to 10 – 12 in-lbs.



The optimal screw penetration into the SMART2 mounting holes is 6 mm (± 1 mm) deep. When selecting screws for mounting the SMART2, ensure the screw penetration does not exceed this specification. Using excessively long screws can damage the SMART2 enclosure.

3. Attach the mounting plate to the mounting location using the mounting holes at each corner of the plate or the adhesive tape.

Typically, attaching the mounting plate to the vehicle using adhesive tape is only used when SMART2 is magnetically mounted to the mounting plate.

Pole Mounting Plate

To install the pole mounting plate:

1. Place the SMART2 on the pole mounting plate.
2. Use four M4 screws to connect the mounting plate to the SMART2. Torque the screws to 10 – 12 in-lbs.



The optimal screw penetration into the SMART2 mounting holes is 6 mm (± 1 mm) deep. When selecting screws for mounting the SMART2, ensure the screw penetration does not exceed this specification. Using excessively long screws can damage the SMART2 enclosure.

3. Screw the mounting place onto a mount, such as a range pole, tribrach or tripod, with a 1" x 14 thread screw. A 5/8" to 1" bushing adapter is available (NovAtel part number 12023275).

2.2 Connect the SMART2 to Data Communication Equipment

The SMART2 can communicate with other devices in the system, such as a computer's serial or Bluetooth port. The SMART2 also has a CAN bus port for communication with other CAN bus compatible devices.

2.2.1 Serial Ports

The SMART2 has three serial ports: COM1, COM2 and COM3. These ports are available on the 14-pin Tyco Ampseal connector. Refer to *SMART2 Connector Overview* on page 13 for the pin out of this connector.

**Table 5: SMART2
Serial Port Protocol**

Port	RS-232
COM1	Yes
COM2	Yes
COM3	Yes

Use the **SERIALCONFIG** command to configure the receiver's asynchronous serial port communications drivers.

Port settings (bit rate and parity, for example) are software configurable. See *Communications with the Receiver* on page 23 for information about configuring the serial ports. Also see *SMART2 Data Communication Specifications* on page 70 for the serial port specifications.

To connect to a serial port:

1. Connect the SMART2 Interface cable (PN: 01019944), or a custom made cable, to the 14-pin Tyco Ampseal connector.

For information about the SMART2 interface cable refer to *Connect I/O Signals to a SMART2* below.

2. Connect the appropriate DB9 connector (COM1, COM2 or COM3) to the serial port on the computer or other data communication device.

2.2.2 CAN Bus Port

The SMART2 has a CAN Bus port available on the 14-Pin interface connector.

To connect to the CAN Bus port:

1. Connect the SMART2 optional accessory cable or a custom made cable, to the main 14-Pin interface connector.

For information about the SMART2 interface cable, see *SMART Antenna Interface Cable (Optional Accessory)* on page 72. This section also has the connector pin out and connector recommendations for making a custom cable.

2. Connect the CAN to the CAN Bus (J5) of the SMART2 interface cable, see *SMART Antenna Interface Cable (Optional Accessory)* on page 72.



The SMART2 CAN bus port is unterminated. If the SMART2 is at the end of the bus, then the connecting cable must have 120 ohms integrated into the cable between CAN1+ and CAN1- in close proximity to the main 14-Pin interface connector.

2.2.3 Bluetooth

Bluetooth is a wireless radio communication standard designed for use over short ranges (within 10 m).

SMART2 receivers equipped with the Bluetooth hardware option support the Bluetooth Classic SPP to provide a Bluetooth virtual serial port: COM6.

2.3 Connect I/O Signals to a SMART2

The SMART2 has several outputs, also referred to as strobes, that provide status and synchronization signals.

- Pulse Per Second (PPS) output (E2 on SMART Antenna Interface cable)
- Emulated Radar Output (E2 on SMART Antenna Interface cable)
- Event Mark Input (MKI) (E2 on SMART Antenna Interface cable)

To access the I/O signals, connect the interface cable or a custom made cable, to the main 14-Pin interface connector. Refer to *SMART Antenna Interface Cable (Optional Accessory)* on page 72 for connector pin out and other details.

2.4 Connect Power to the SMART2

To connect power to the SMART2:

1. Connect the SMART2 Interface Cable (01019944) to the 14-Pin connector on the back of the SMART2. See *SMART Antenna Interface Cable (Optional Accessory)* on page 72 for information about this cable.

2. Connect the BATT+ and BATT- bare wires of the interface cable to a +7 to +30 VDC power supply. For details about the power supply required, see *Power Supply Requirements for the SMART2* below.

2.4.1 Fuse for the Power Supply

Install a user supplied 5 A slow blow fuse in the positive line of the connection to the power source to protect the power supply wiring and your warranty.

Figure 5: Power Supply Fuse

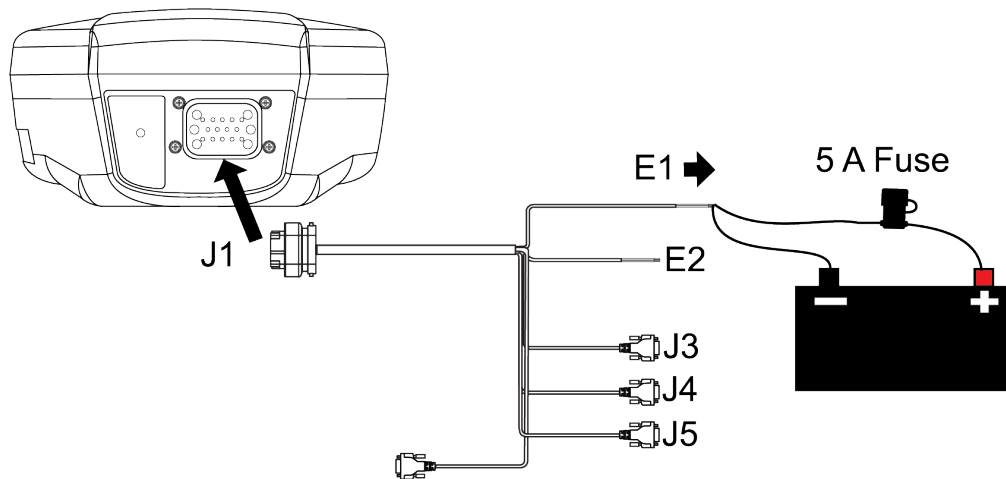

Refer to *SMART Antenna Additional Equipment Required* on the next page for fuse recommendations.

2.4.2 Power Supply Requirements for the SMART2

The SMART2 requires a power supply that provides:

- a voltage in the range of +7 to +30 VDC, current consumption 500 mA
- at least 15 W of power (typical use: 2.5 W)

See *Table 16: SMART2 Power Requirements* on page 69 for more power supply specifications.

The SMART2 has an internal power module that:

- filters and regulates the supply voltage
- protects against over-voltage, over-current and high-temperature conditions
- provides automatic reset circuit protection



If the voltage supplied is below the minimum specification, the receiver suspends operation. If the voltage supplied is above the maximum specification, the receiver may be permanently damaged, voiding the warranty.

The supply must be capable of providing enough current to operate the SMART2, including the initial inrush transient. The supply must also be current limited to 5 A with an external fuse.



The amount of power required depends on the number of constellations and signals tracked, and the features enabled.

Refer to *SMART Antenna Interface Cable (Optional Accessory)* on page 72 for details about the power cable.

2.5 Check that the SMART Antenna is Working

After the SMART Antenna is installed and powered up, use the following procedure to ensure the receiver is operating.

1. Check that the Status LED  has changed from red to yellow or green.

The Status LED may briefly flash as Red before moving quickly to the Fast Flash Yellow.

See *SMART2 LED* on page 14 for the LED location.

2. Send the following command:

```
LOG VERSION
```

The VERSION log is returned.

```
[COM1]<VERSION COM1 0 83.0 FINESTEERING 2061 167959.862 1a04c000 3681
15699
< 8
< GPSCARD "DSNLNNTMNT0G" "BMW19050037L" "OEM2500-1.00"
"OA7CR0602RN0000" "OM7BR0100RBG000" "2019/Jun/28" "09:09:16"
< EMBEDDED_AUTH "GSNNNNNNN" "?MWR?????????" "NO_HW_VER" "NO_EXPIRY_
DATE" "" "2019/Jun/28" "09:09:35"
< APPLICATION "" "" "" "ES2AR0602RN0000" "" "2019/Jun/28" "09:09:43"
< DEFAULT_CONFIG "" "" "" "ES2CR0602RN0000" "" "2019/Jun/28"
"09:09:58"
< PACKAGE "" "" "" "ES2PR0602RN0000" "" "2019/Jun/28" "09:09:49"
< ENCLOSURE "SMART2-TB" "NMVK19060013V" "" "" "" "" ""
< BLUETOOTH "" "0081F91AFBBF" "BT121" "BT1210100RN0000" "1.2.0-208"
"2019/05/09" "15:16:47"
< IMUCARD "IAM 20680" "" "" "" "" "" ""
```



The Log version output will vary depending on SMART Antenna hardware option.

3. Check that the Time Status is **FINESTEERING** which represents that time is fine set and being steered.
4. Check the Receiver Status word (1a04c000 in this example). If the lowest bit (bit 0) is set, the receiver has errors.



For information about the other digits in Receiver Status word, refer to the **RXSTATUS** log.

2.6 SMART Antenna Additional Equipment Required

In order for a SMART Antenna to perform optimally, the following additional equipment is required:

- A computer (user supplied)
- A cable harness for communicating with and powering the SMART Antenna (NovAtel *SMART Antenna Interface Cable (Optional Accessory)* on page 72 is available with four DB-9 connectors, six bare cables and a SMART Antenna connector)
- A fused +7 to +30 VDC power supply (user supplied)
Refer to *Power Supply Requirements for the SMART2* on the previous page for details.

Table 6: SMART Antenna Recommended Fuse and Fuse Holders

Fuse	Recommended Fuse/Fuse Holder		
12 V System Fuse (standard size blade)	ATO Silver Blade Fuse 5 A (32 V) or equivalent	Littelfuse	0287005
12 V System Fuse (mini size blade)	Mini Blade Fuse 5 A (32 V) or equivalent	Littelfuse	0297005
24 V System Fuse High Reliability, Harsh Environment (standard size blade)	FKS ATO Blade Fuse 5A (80 V) or equivalent	Littelfuse	166.7000.450
Inline Fuse Holder, (for standard size blade)	Waterproof ATO Fuse Holder	Littelfuse	FHAC0001
Inline Fuse Holder, (for mini size blade)	Waterproof Mini Fuse Holder	Littelfuse	0FHM0001



The Recommended Fuse and Fuse Holders table details the part numbers for recommended fuses and fuse holders. These numbers are provided for information only and are not available from NovAtel as separate parts.

Chapter 3 SMART2 Operation

Before operating the receiver for the first time, refer to *SMART2 Overview* on page 13 for SMART2 installation instructions.

Refer to *Communications with the Receiver* below to begin configuring the SMART2 for operation.

3.1 Communications with the Receiver

Communication is established with the receiver using a data terminal or computer connected to the receiver by a variety of methods:

- *Serial Port Communications* below
- *CAN Bus Communications* on the next page
- *Bluetooth® Communications* on the next page (SMART2-B and SMART2-TB hardware options only)

When connected to the receiver, enter commands directly from a terminal or through terminal emulation software on a computer. For example:

- **NovAtel Application Suite** - NovAtel Application Suite is set of computer based applications that simplify the configuration and monitoring of NovAtel receivers. For information about installing and using NovAtel Application Suite, refer to the online documentation (docs.novatel.com/Tools).
- Any console/command line application

To maximize the application of the receiver's capabilities, become familiar with the commands and logs described in [Agriculture Commands and Logs Reference Manual](#).

3.1.1 Serial Port Communications

The receiver can communicate with a computer or terminal via a serial port. For communication to occur, both the receiver and the operator interface have to be configured properly. The receiver's default port settings are:

- 9600 bps
- no parity
- 8 data bits
- 1 stop bit
- no handshaking
- echo off
- break on

The data transfer rate determines how fast information is transmitted. Take for example a log whose message byte count is 96. The default port settings allows 10 bits/byte (8 data bits + 1 stop bit + 1 framing bit). It therefore takes 960 bits per message. To get 10 messages per second then requires 9600 bps. Also remember that even if you set the bps to 9600, the actual data transfer rate may be lower and depends on the number of satellites being tracked, data filters in use, and idle time. It is therefore suggested that you leave yourself a margin when choosing a data rate.



The minimum suggested baud rate for most applications is 115200 bps. If the buffer overrun flag is present in the **RXSTATUS** log (refer to the [Agriculture Commands and Logs Reference Manual](#)), log at a higher baud rate if possible.



Although the receiver can operate at data transfer rates as low as 300 bps, this is not recommended. For example, if several data logs are active (that is, a significant amount of information needs to be transmitted every second) but the bit rate is set too low, data overflows the serial port buffers, causing an error condition in the receiver status that results in lost data.

The following ports are supported and can be configured using the commands listed.

Table 7: Serial Ports Supported

Receiver Type	Port Supported	Configuration Command
SMART2	COM1, COM2, COM3	SERIALCONFIG

Change the COM Port Settings

To change the settings on a COM port, use the **SERIALCONFIG** command. For example:

- To change the data rate of COM2 to 115200, enter:

```
SERIALCONFIG COM2 115200
```

- To change the data rate of COM1 to 57600 and enable even parity, enter:

```
SERIALCONFIG COM1 57600 E
```

Communicating using a Remote Terminal

One method of communicating with the receiver is through a remote terminal. To communicate with the terminal, the receiver requires only the RX, TX and GND lines be used. Ensure the terminal's communications set up matches the receiver's port settings.

Communicating using a Computer

A computer can emulate a remote terminal as well as provide the added flexibility of supporting multiple command batch files and data logging storage files. Use any standard communications software package that emulates a terminal to establish bidirectional communications with the receiver. Examples include NovAtel Application Suite and PuTTY. All data is sent as raw 8-bit binary or ASCII characters.

Refer to *Communicating with the Receiver* on the next page for details.

3.1.2 CAN Bus Communications

The SMART2 supports J1939 and NMEA2000 CAN protocols.

The SMART2 has one CAN port—CAN1. CAN1 port supports data rates of up to 500 kbits/s.

Proper bus termination is required.

Refer to *SMART2 CAN Bus* on page 36 for details instructions.

3.1.3 Bluetooth® Communications

SMART2-B and SMART2-TB receivers support the Bluetooth Serial Port Profile to provide wireless access to the receiver's internal COM6 port. Prior to connecting to this port, your device must first be paired to the receiver.



Bluetooth support for Apple® products require that a custom application be developed. Contact Apple for details about creating a custom application.

Pairing Bluetooth Devices on Windows 10

On a Bluetooth capable computer, perform the following steps.

1. Using the Windows key + I keyboard shortcut, open the *Windows Settings* app and select *Devices*.
2. Select *Bluetooth & other devices* and after ensuring the Bluetooth switch is in the On position, click *Add Bluetooth or other device*.
3. In the *Add a device* window, select *Bluetooth*.
4. Select the SMART2 receiver from the list of nearby Bluetooth devices.
5. Once Windows 10 has completed the pairing process, check which Bluetooth Serial Port number has been assigned to the receiver by selecting *Devices and Printers*.
6. Right-click on the SMART2 device and select *Properties*.
7. In the Properties window, select the *Services* tab. Ensure the Serial port box is checked and record the assigned COM port.

3.2 Getting Started

The receiver's software resides in flash memory. When first powered, it undergoes a complete self-test. If an error condition is detected during the self-test, the status word changes. This self-test status word can be viewed in the header of any data output log. Refer to Messages in the [Agriculture Commands and Logs Reference Manual](#) for header information. If a persistent error occurs, contact your local NovAtel dealer. If the dealer cannot resolve the problem, contact NovAtel Customer Support directly using one of the methods listed in *Customer Support* on page 10.

3.2.1 Communicating with the Receiver

You can communicate with the receiver using NovAtel Application Suite or a terminal emulation program.



For instructions on using NovAtel Application Suite, refer to docs.novatel.com/Tools.

When the receiver is first turned on, no data is transmitted from the COM ports except for the port prompt.

Any of the COM port prompts indicate that the receiver is ready and waiting for command input. The screen may display other port names for other port types.



1. Output from receiver self-tests may take some time. On startup, the receiver is set to log the RXSTATUSEVENTA log ONNEW on all ports. See *RXSTATUSEVENT Log* on page 40 for more details.
2. If NovAtel Application Suite is unable to locate the receiver, use a different COM port to communicate with the receiver. When communication has been established, issue a **FRESET STANDARD** command. The original communications port should be ready for use. See the **FRESET** command for more information.

An example of a response to an input **LOG** command:

```
[COM2] LOG COM1 BESTPOS ONTIME 1
```

<OK

In this example, [COM2] is the port prompt.

If the command was accepted, the receiver responds with:

<OK

If a command is entered incorrectly, the receiver responds with:

<ERROR:Invalid Message ID (or a more detailed message)



Ensure the computer does not sleep or hibernate during a logging session or data will be lost.

3.3 GLIDE

NovAtel's GLIDE is a positioning algorithm for single-frequency GPS and GPS/GLONASS applications. GLIDE produces a smooth position output tuned for applications where time relative accuracy (pass-to-pass) is more important than absolute accuracy. Because of this, it is well suited for agricultural applications.

Multipath signals tend to induce time varying biases and increase the measurement noise on the L1/L2 pseudorange measurements. Carrier phase measurements are much less susceptible to the effects of multipath. The GLIDE algorithm fuses the information from the L1 code and the L1 phase measurements into a Position Velocity Time (PVT) solution.

GLIDE includes settings for a dynamic mode, a static mode and an "auto" mode, where the filtering parameters are automatically adjusted as vehicle velocity varies between stationary and dynamic states.

3.3.1 Dual-Frequency GLIDE

NovAtel's dual-frequency GLIDE technology adds to the superior pass-to-pass performance provided by single-frequency GLIDE. Dual-frequency GLIDE is ideal for agricultural and machine guidance applications where relative positioning is critical. Using GLIDE significantly reduces the variation in position errors to less than 1 cm from one epoch to the next. Dual-frequency GLIDE improves the absolute accuracy of the GLIDE position and creates a robust solution resistant to the effects of high ionospheric activity. GLIDE works in all code positioning modes, including single point, DGNSS and SBAS.

Refer to the NovAtel white paper on [GLIDE Technology](#) for more information on GLIDE and [APN-038: Pseudorange/Delta-Phase \(PDP\) and GLIDE Filters](#) along with other information available from nova-tel.com/support/support-materials/application-notes.

3.3.2 PDP and GLIDE Configurations

Pseudorange/Delta-Phase (PDP) and GLIDE position filters can be used for single-frequency single point, WAAS or DGNSS positioning. Refer to the **PDPFILTER** command and **PDPMODE** command .

To reset the PDP or GLIDE filter:

```
pdpfilter reset
```

To enable the PDP filter:

```
pdpfilter enable
```

Ensure the **PDPFILTER** command is used before the **PDPMODE** command. Set the PDP type and kinematic type according to the application. For most kinematic applications:

```
pdpmode relative dynamic or pdpmode relative auto
```

The rest of the setup is position type and log dependent according to the application. . Also refer to the NovAtel application note [APN-038: Pseudorange/Delta-Phase \(PDP\) and GLIDE Filters](#) available from our web site at novatel.com/support/support-materials/application-notes.

3.4 Enabling SBAS Positioning

SMART2 receivers are capable of SBAS positioning. This positioning mode is enabled using the **SBASCONTROL** command:

```
sbascontrol enable auto
```

When the command is entered, the SMART2 automatically tracks the SBAS that is operating in the region (e.g., WAAS or EGNOS) and applies the corrections from the service. On a simulator, leave the test mode parameter off or specify NONE explicitly. For more on SBAS, refer to application note [APN-051 Positioning Modes of Operation](#) (additional Application Notes available at novatel.com/support/support-materials/application-notes) and the known solution [SBAS Positioning](#).

3.5 Enabling PPP

L-Band equipped receivers can achieve sub-meter position accuracy using correction data received from geostationary satellites. To use the L-Band corrections, an L-Band-capable receiver model is required (refer to our web site novatel.com/products/antennas for information on NovAtel L-Band-capable antennas).

For information on getting started with TerraStar Correction Services, refer to:

- [TerraStar Correction Services Quick Start Guide](#)

For more information on L-Band positioning, refer to:

- NovAtel Application Notes: *APN-061: NovAtel CORRECT with PPP using TerraStar Corrections* available from novatel.com/support/support-materials/application-notes
- the [Agriculture Commands and Logs Reference Manual](#) for log/command details and/or
- visit novatel.com/support
- visit novatel.com/products/correction-services

3.5.1 TerraStar Subscriptions

A subscription is required to use TerraStar service for land, airborne and near shore applications. Near shore applications are defined as vessels operating within 10 km of shore. For more information about TerraStar services, visit novatel.com/products/correction-services/terrestar-correction-services. To obtain a subscription, contact your local NovAtel sales representative. The NovAtel product serial number (PSN) is needed to obtain a subscription. To obtain the receiver serial number, enter the following command:

```
log version once
<VERSION COM1 0 83.0 FINESTEERING 2061 167959.862 1a04c000 3681 15699
< 8
< GPSCARD "DSNLNNTMNT0G" "BMWR19050037L" "OEM2500-1.00" "OA7CR0602RN0000"
"OM7BR0100RBG000" "2019/Jun/28" "09:09:16"
< EMBEDDED_AUTH "GSNNNNNNN" "?MWR?????????" "NO_HW_VER" "NO_EXPIRY_DATE"
"" "2019/Jun/28" "09:09:35"
< APPLICATION "" "" "" "ES2AR0602RN0000" "" "2019/Jun/28" "09:09:43"
< DEFAULT_CONFIG "" "" "" "ES2CR0602RN0000" "" "2019/Jun/28" "09:09:58"
< PACKAGE "" "" "" "ES2PR0602RN0000" "" "2019/Jun/28" "09:09:49"
< ENCLOSURE "SMART2-TB" "NMVK19060013V" "" "" "" "" ""
```

```
< BLUETOOTH "" "0081F91AFBBF" "BT121" "BT1210100RN0000" "1.2.0-208"
"2019/05/09" "15:16:47"
< IMUCARD "IAM 20680" "" "" "" "" "" ""
```

In the example above, the receiver serial number is **BMWR19050037L**.

To activate a subscription, the receiver must be powered and tracking an L-Band TerraStar satellite prior to the planned activation time. Use the **ASSIGNLBANDBEAM** command to configure the receiver to track the TerraStar satellite.

```
ASSIGNLBANDBEAM auto
```

To confirm tracking of an L-Band signal, log the L-Band tracking status information by entering the following command:

```
log lbandtrackstata

#LBANDTRACKSTATATA, COM1, 0, 73.5, FINESTEERING, 1769, 328196.000, 00000000, 29fd,
12602;1, "98W", 1539902500, 1200, 974c, 00c2, 0, -316.186, 43.842, 4.3840, 61.920,
1088, 2, 2, 138176, 79, 0.0001*3e43cb7d
```

If receiving an L-Band signal from a geostationary satellite, the sixth field following the header (tracking status word) of the LBANDTRACKSTAT log will be 00c2, as shown in the example.



The latest services and coverage can be obtained from novatel.com/products/correction-services/terrastar-correction-services. For additional information on TerraStar activation, contact NovAtel Customer Service at novatel.com/support or download *APN-061 NovAtel CORRECT with TerraStar* from: novatel.com/support/support-materials/application-notes

To confirm the TerraStar subscription status, send the **TERRASTARSTATUS** log:

```
log terrastarstatus

[COM1]<TERRASTARSTATUS COM1 0 74.0 FINESTEERING 1886 418216.025 00000020 fdc1
13386 ENABLE LOCKED 0 IN_RANGE DISABLED
[COM1]
```

The first field after the log header will be **ENABLE** to indicate the TerraStar subscription is valid. The second field after the log header will be **LOCKED** to indicate the decoder is locked to the data format.

To monitor the PPP convergence, request the **PPPPOS** log:

```
log ppppos ontime 1

[COM1]<PPPPOS COM1 0 76.0 FINESTEERING 1886 418465.000 00000020 ec34 13386 SOL_
COMPUTED PPP_CONVERGING 51.11679035745 -114.03886212905 1064.9475 -16.9000
WGS84 0.7097 0.6867 1.2333 "TSTR" 25.000 0.000 18 17 17 17 00 00 00 33
[COM1]
```

3.6 Terrain Compensation

The Terrain Compensation feature corrects for errors in position caused by the roll and pitch of the vehicle. The SMART Antenna senses the vehicle's roll and pitch angle and, with the user-entered "height above ground", compensates the position output to give the position under the vehicle rather than at the antenna.



Vehicle motion is required to compute and obtain terrain-compensated positions.

As shown in *Figure 6: Terrain Compensation – Roll* below and *Figure 7: Terrain Compensation – Pitch* below, if a vehicle is operating on sloped terrain, the position will be in error by an amount proportional to the roll or pitch angles.

Figure 6: Terrain Compensation – Roll

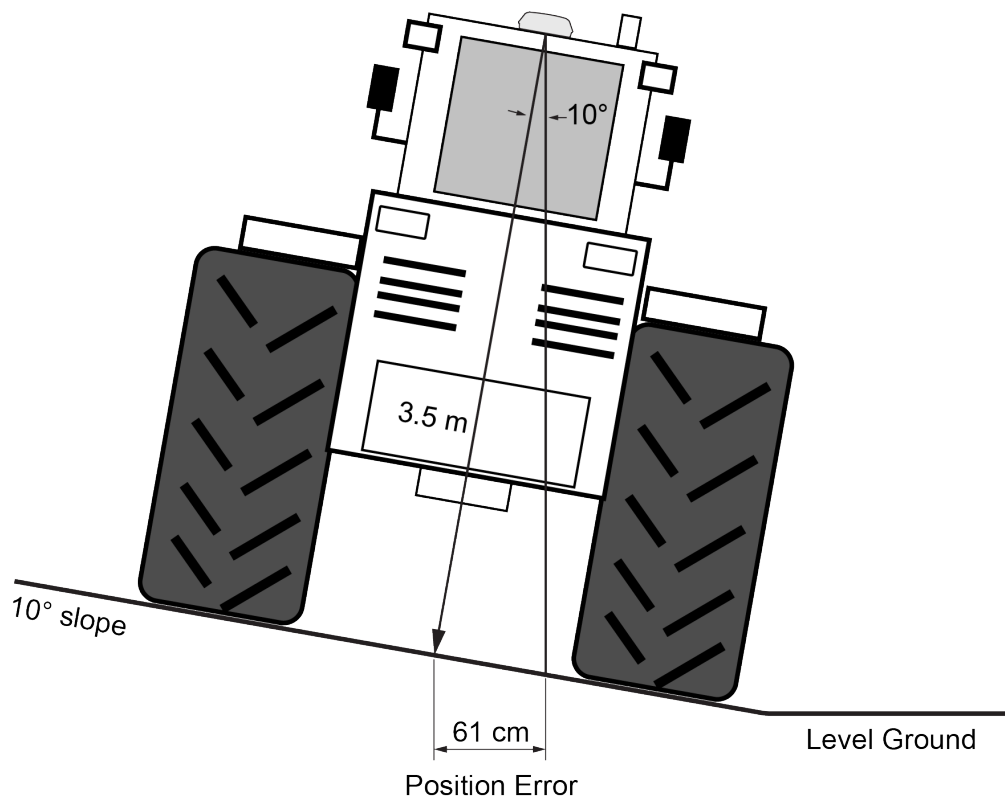
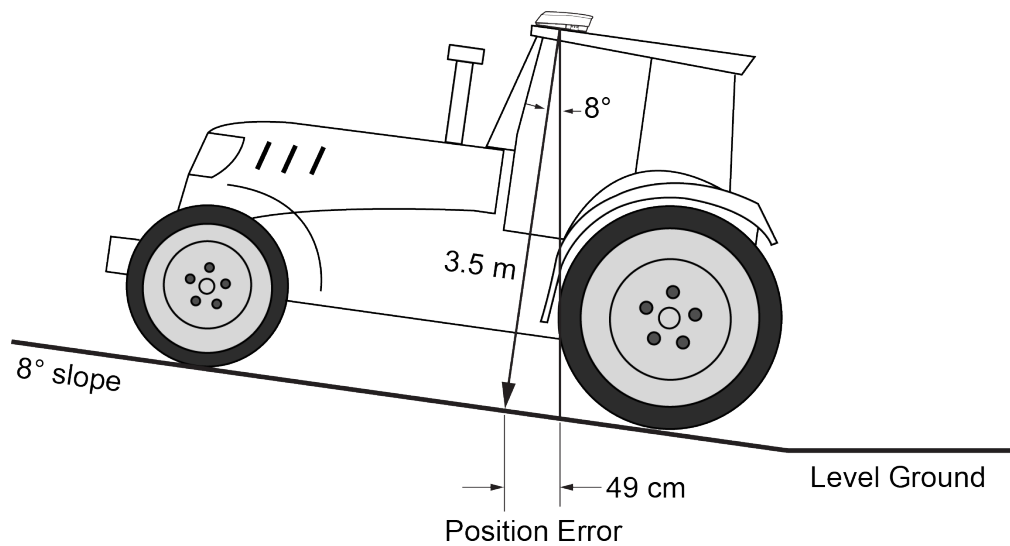

Figure 7: Terrain Compensation – Pitch



If terrain compensation is enabled, the SMART Antenna determines the roll and pitch angles and corrects the position data before it is forwarded to the user equipment. In the example shown in *Figure 6: Terrain Compensation – Roll* on the previous page, the roll angle is 10 degrees, so the position correction that needs to be applied is 61 cm. In the example shown in *Figure 7: Terrain Compensation – Pitch* on the previous page, the pitch angle is 8 degrees, so the position error that needs to be applied is 49 cm.

The following logs provide terrain compensated positions:

- **BESTPOS** log
- **BESTXYZ** log
- **BESTUTM** log
- **GPGGA** log
- **GPGGALONG** log
- **GPGLL** log
- **GPRMC** log
- **PGN129025** NMEA log
- **PGN129027** NMEA log
- **PGN129029** NMEA log

Terrain Compensation is available on the following SMART Antennas:

- SMART7
- SMART7-I
- SMART7-W
- SMART2-TB

3.6.1 Configuring Terrain Compensation

To fully install and set up Terrain Compensation:

1. Mount the SMART Antenna on the vehicle.
2. Measure and set the height of the SMART Antenna from the ground to the bottom of the antenna.
3. Level the tilt sensor.
4. Save the Terrain Compensation configuration data.

Mount the SMART Antenna

The SMART Antenna must be mounted as close to the center of the vehicle as possible, as illustrated in *Figure 8: SMART Antenna Installation* on the next page.

Figure 8: SMART Antenna Installation

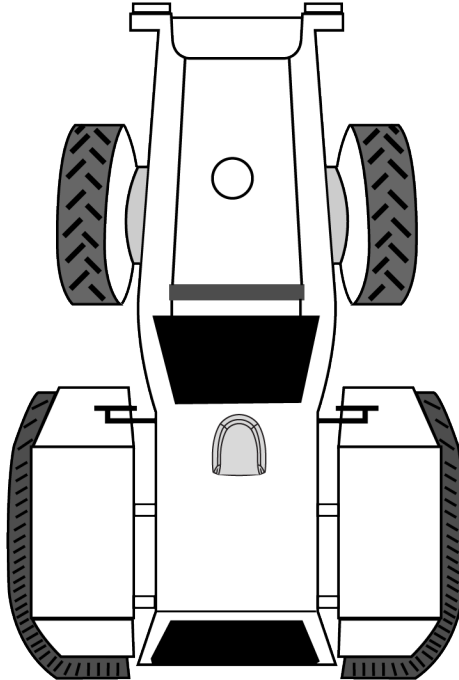

The SMART Antenna must be mounted with the connector facing the rear of the vehicle, as shown in *Figure 9: SMART Antenna Orientation* below.

Figure 9: SMART Antenna Orientation

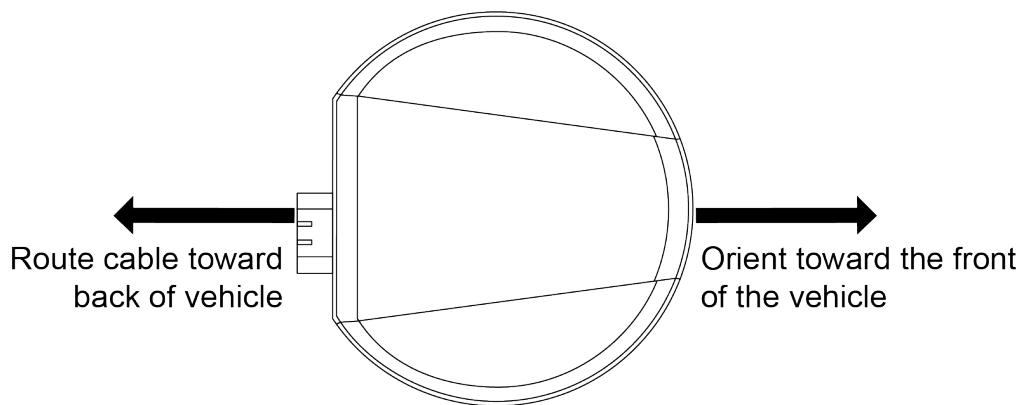

The SMART Antenna must be rigidly secured to the vehicle to minimize errors due to vibration and motion.

Set the SMART Antenna Height and Enable Terrain Compensation

The height measurement should be made while the vehicle has the correct tire pressure and is parked on a hard-packed and level surface. The measurement should be made, in meters, from the ground to the bottom of the SMART Antenna. The measurement accuracy should be within 2.5 to 5.0 cm.

Figure 10: Antenna Height Measurement

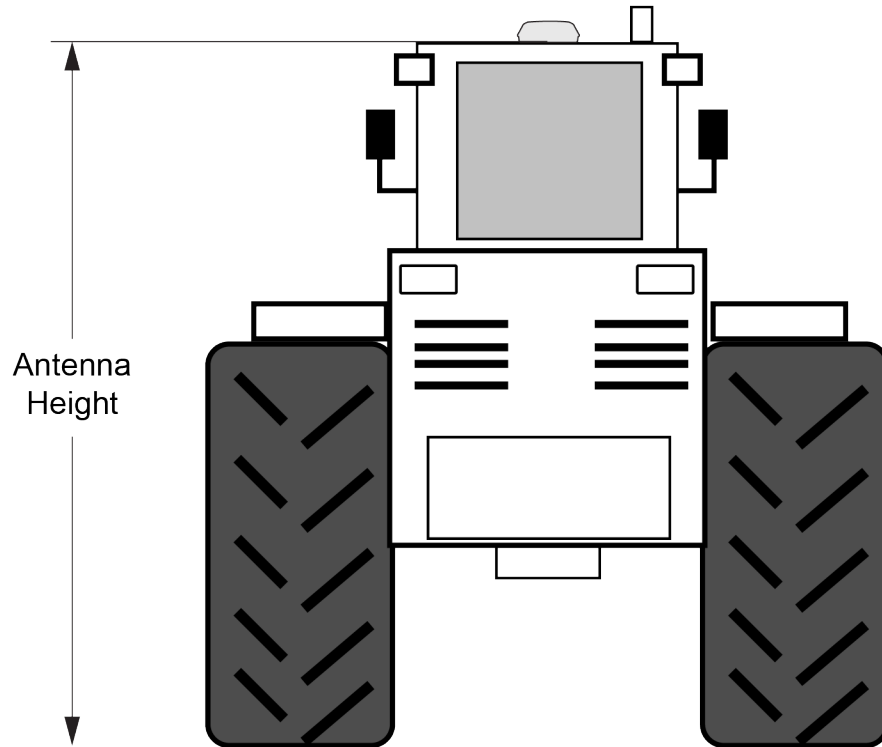

After the measurement has been made, use the **TILTFILTER** command to set the height of the SMART Antenna.

To set the height in meters, enter the following command:

```
TILTFILTER switch antennaheight
```

Where:

switch enables or disables Terrain Compensation
antennaheight is the height measurement in meters

For example, to enable Terrain Compensation and set the SMART Antenna height to 3.5 meters, enter the following command:

```
TILTFILTER ENABLE 3.5
```

For more information, refer to the **TILTFILTER** command.



Changes in tire pressure over time can potentially cause errors in Terrain Compensation. This is because the height of vehicle can vary with tire pressure.

Leveling the Terrain Compensation Sensor

Two-stage zeroing should be used to level the Terrain Compensation sensor whenever possible.

Two-Stage Zeroing

Two-stage zeroing is the best way to level the Terrain Compensation sensor.



Zeroing the Terrain Compensation sensor while moving will negatively impact performance. Always ensure the vehicle is stationary before zeroing the sensor.



Two-Stage zeroing must be completed outside with good GNSS visibility. A level surface is not required.

To level the Terrain Compensation sensor, complete the following:

1. Park the vehicle where you can return to the same location but facing the opposite direction.
2. Ensure that you have good GNSS visibility.
3. Remain stationary for 15 seconds.
4. Begin the zeroing by issuing the following command:

```
TILTZERO NEW
```
5. Re-position the vehicle so that it is parked facing the opposite direction on the same spot, as close to 180 degrees as possible.
6. Remain stationary for 15 seconds.
7. Complete zeroing by issuing the following command:

```
TILTZERO ADD
```

For more information, refer to the **TILTZERO** command.

Single-Stage Zeroing

Single-stage zeroing can be used as an alternative to two-stage zeroing.



Zeroing the Terrain Compensation sensor while moving will negatively impact performance. Always ensure the vehicle is stationary before zeroing the sensor.



A known level surface, such as a concrete floor of a shed or workshop, is required to perform the leveling using the single-stage zeroing procedure. GNSS visibility is not required.

To level the Terrain Compensation sensor, complete the following:

1. Park the vehicle on a known level surface.
2. Remain stationary for 15 seconds.
3. Complete zeroing by issuing the following command:

```
TILTZERO ZERO
```

For more information, refer to the **TILTZERO** command.

Saving the Terrain Compensation Configuration

After the height has been set or the Terrain Compensation sensor has leveled, the Terrain Compensation configuration must be saved. This is done so the height data and level setting are saved between power cycles. To save Terrain Compensation configuration, enter the following command:

TILTZERO SAVE

For more information, refer to the **TILTZERO** command.

3.6.2 Configuring Terrain Compensation using a NMEA Command

Terrain Compensation can also be configured using the NMEA style command, \$PMDT.



Using the **\$PMDT** command is an alternative to using the **TILTFILTER** and **TILTZERO** commands. Either method will successfully configure the Terrain Compensation feature, however only the single-stage zeroing procedure is supported with the **\$PMDT** command. For best performance, two-stage zeroing is recommended.

Setting the SMART Antenna Height

The height measurement should be made while the vehicle has the correct tire pressure and is parked on a hard-packed and **level** surface. The measurement should be made from the ground to the bottom of the SMART Antenna connector. The measurement accuracy should be within 1 to 2 inches (2.5 to 5.0 cm).

After the measurement has been made (in feet and inches, or meters), use the **\$PMDT** command to set the height of the SMART Antenna.

To set the height in feet and inches, enter the following command:

```
$PMDT,u,,x,y*hh
```

Where:

- x = the feet portion of the height measurement
- y = the inches portion of the height measurement
- hh = NMEA check sum

For example, entering the command **\$PMDT,u,,1,1*78** will set the SMART Antenna height to 1 foot and 1 inch.

To set the height in meters, enter the following command:

```
$PMDT,a,,,,x.x*hh
```

Where:

- x.x = the height measurement in meters
- hh = NMEA check sum

For example, entering the command **\$PMDT,u,,,2*66** will set the SMART Antenna height to 2 meters.

The SMART Antenna is shipped from the factory with the height set to 0.0 meters.

For more information, refer to the **\$PMDT** command.



Changes in tire pressure over time can potentially cause errors in Terrain Compensation. This is because the height of vehicle can vary with tire pressure.

Leveling the Terrain Compensation Sensor

The vehicle must be parked on flat ground when the level command is sent to the SMART Antenna.

To level the Terrain Compensation sensor, enter the following command:

```
$PMDT, 1*4D
```

For more information, refer to the **\$PMDT** command.

Saving the Terrain Compensation Configuration

After the height has been set or the Terrain Compensation sensor has leveled, the Terrain Compensation configuration must be saved. This is done so the height data and level setting are saved between power cycles. To save Terrain Compensation configuration, enter the following command:

```
$PMDT, x*59
```

For more information, refer to the **\$PMDT** command.

3.7 SMART Antenna Emulated Radar

3.7.1 Emulated Radar (ER)

A typical radar sensor emits radio beams that bounce off the ground and computes ground speed based on the speed at which objects are passing in front of the sensor. The output of the sensor is a digital pulse, the frequency of which is proportional to the vehicle's ground speed. This is often used in agricultural applications such as planting and spraying. The SMART Antenna eliminates the need for separate ground-sensing radar equipment by converting the GPS-derived velocity to a proportional frequency output. The following emulated radar signal parameters can be configured by the customer:

- Frequency Step: Specifies how the frequency output relates to the vehicle speed.
- Signal Update Rate: Specifies how often the frequency output is updated to match the vehicle speed.
- Response Mode: Specifies how quickly changes in velocity are reflected in the frequency output. Setting a slower response mode reduces spikes (noise) in the velocity but increases latency. Setting a higher response mode reduces latency, but may result in noisier frequency output.

Refer to **RADARCONFIG** command for detailed information.

After it is configured using the **RADARCONFIG** command, Emulated Radar (ER) pulses are output through the SMART Antenna interface cable and the **RADARSTATUS** log.

3.8 Logging Using NovAtel Application Suite or Setup & Monitor (Web)

The NovAtel user interface tools, *NovAtel Application Suite* and *Setup & Monitor (Web)*, provide a graphic user interface to configure the logs output from an OEM7 receiver.

For information about configuring logging using NovAtel Application Suite, refer to [doc-s.novatel.com/Tools/Content/Setup_Monitor/ConfigurationLogging.htm](https://www.novatel.com/Tools/Content/Setup_Monitor/ConfigurationLogging.htm).

For information about configuring logging using Setup & Monitor (Web), refer to [doc-s.novatel.com/Tools/Content/WebUI_ConfigurationWindows/LoggingConfig.htm](https://www.novatel.com/Tools/Content/WebUI_ConfigurationWindows/LoggingConfig.htm).



For information about using NovAtel Application Suite or Setup & Monitor (Web), refer to [doc-s.novatel.com/Tools](https://www.novatel.com/Tools).

Chapter 4 SMART2 CAN Bus

The SMART2 supports the transmission of NMEA2000 messages over the CAN bus.

By default, CAN is disabled on the SMART2. Critical CAN configuration parameters such as Parameter Group Numbers (PGNs), addresses and priorities are system-specific and must be explicitly configured.

The addresses and PGNs are typically allocated when the overall CAN bus topology is determined. A Node has a unique CAN J1939 NAME and address.



The SMART2 has internal CAN transceivers, however they still require proper bus terminations.

Refer to *Table 19: SMART Antenna Interface Cable Connector Pin Out* on page 73 for pin-out information.

The SMART2 supports the following NMEA2000 Parameter Group Messages (PGN) over the CAN bus:

- PGN 126992 System Time
- PGN 129025 GNSS Position Rapid Update
- PGN 129026 COG & SOG Rapid Update
- PGN 129027 Position Delta High Precision Rapid Update
- PGN 129029 GNSS Position
- PGN 129551 GNSS Differential Signal

The following commands and logs are used for CAN configuration:

- **CANCONFIG** command: controls the CAN transceiver hardware and places the receiver *on bus* or *off bus*
- **J1939CONFIG** command: assigns the CAN J1939 NAME and address parameters to a Node
- **J1939STATUS** log: reports the status a Node on the J1939 CAN network, such as the claimed address
- **LOG CCOMx PGNabcd**: configures the NMEA2000 messages



CCOM ports with a lower port number have a higher transmission priority.



For information about these commands, see the [Agriculture Commands and Logs Reference Manual](#).



Details for the PGN messages can be found in the NMEA2000 specification which can be purchased directly from the National Marine Electronics Association (www.nmea.org/).

4.1 Default Configuration

After a FRESET, the receiver has the following CAN configuration:

- The CAN physical port is disabled
- No J1939 addresses are claimed
- The CCOM1 port is configured for NMEA2000 messages only

Table 8: Default NAME

Parameter	Value
Address	0x1C
Industry Group	2
Device Class	0
Device Class Instance	0
Function	23
Function Instance	0
ECU Instance	0
Manufacturer Code	305

4.2 Configuring the CAN Bus

To enable a SMART2 to communicate over the CAN bus, configure CAN and place the receiver *on bus*, triggering a J1939 *Address Claim Procedure*.

1. Use the **J1939CONFIG** command to specify J1939 NAME and desired address.

This step is optional and only required if the default NAME parameters are to be changed.

2. Use the **CANCONFIG** command to place the receiver *on bus*.
3. Optionally, use the **J1939STATUS** log to monitor CAN status on the receiver.

4.2.1 Configuration Notes

- The **J1939CONFIG** and **CANCONFIG** commands can be entered in any order. After the **CANCONFIG** command is used to place the receiver on the CAN bus, **J1939CONFIG** commands take effect immediately. Until then, J1939CONFIG can be entered many times to change the settings because they have not taken affect yet (the receiver is not yet on the bus).
- The J1939 Address claim procedure is executed if and only if both J1939CONFIG NODEx CANx and CANCONFIG CANx ON are entered.
- Use J1939STATUS log to determine the receiver's CAN status and the actual address claimed by a particular node.
- Once the receiver is "on bus", it must be taken "off-bus" using CANCONFIG for any further configuration changes using J1939CONFIG.
- The receiver is fully "on-bus" only once the J1939 address has been successfully claimed. This is reported as "CLAIMED" status by J1939STATUS log.
- No messages will be sent or received until the receiver is "online" and an address is claimed. Outgoing messages are not buffered; they are discarded until the receiver is online.

4.2.2 Example of Enabling the CAN Bus

1. `LOG J1939STATUS ONCHANGED`
2. `J1939CONFIG NODE1 CAN1 <addresses>`
3. `CANCONFIG CAN1 ON 250K`

4. SAVECONFIG

```
< J1939STATUS NODE1 DISABLED 0 0xFE
< J1939STATUS NODE1 CLAIMING 1 <address>
< J1939STATUS NODE1 CLAIMED <attempt count> <address>
```

4.2.3 Example of Modifying the CAN Bus Parameters

1. LOG J1939STATUS ONCHANGED
2. CANCONFIG CAN1 OFF
3. J1939CONFIG NODE1 CAN1 <addresses>
4. CANCONFIG CAN1 ON
5. SAVECONFIG

```
< J1939STATUS NODE1 DISABLED 0 0xFE
< J1939STATUS NODE1 CLAIMING 1 <address>
< J1939STATUS NODE1 CLAIMED <attempt count> <address>
```

4.2.4 Example of Detecting an Address Claim Failure and Reconfiguring

1. LOG J1939STATUS ONCHANGED
2. J1939CONFIG NODE1 CAN1 <addresses>
3. CANCONFIG CAN1 ON

```
< J1939STATUS NODE1 DISABLED 0 0xFE
< J1939STATUS NODE1 CLAIMING 1 <address>
< J1939STATUS NODE1 FAILED <attempt count> 0xFE
```

4. CANCONFIG CAN1 OFF
5. J1939CONFIG NODE1 CAN1 <addresses>
6. CANCONFIG CAN1 ON

```
< J1939STATUS NODE1 DISABLED 0 0xFE
< J1939STATUS NODE1 CLAIMING 1 <address>
< J1939STATUS NODE1 CLAIMED <attempt count> <address>
```

4.2.5 Address Claim Procedure

To become operational on the CAN bus, a SMART2 must claim a J1939 address. The preferred address and a range of alternative addresses are specified using the **J1939CONFIG** command. When a configured receiver is placed *on bus*, it may make multiple attempts to claim an address. It may also have its address bumped by a higher priority device claiming the same address.

While the device is attempting to claim an address, the **J1939STATUS** log reports a status of *CLAIMING* and automatically tries to claim the next allowed address. Depending on the **J1939CONFIG** parameters, an address different from the **J1939CONFIG preferred address** may be claimed or the address claim procedure can fail entirely. If no addresses could be claimed, a *FAILED* status is reported and the receiver takes no further action. To recover from this failure, take the receiver *off bus* using the **CANCONFIG** command and change the CAN address configuration using the **J1939CONFIG** command.

The address can also be assigned using J1939 *Commanded Address* message sent by another ECU on the bus, such as a tester unit. The commanded address always overrides the address specified using **J1939CONFIG** command. When the *Commanded Address* is received, the receiver reports a status of *CLAIMING* followed by *CLAIMED*. Restarting CAN using the **J1939CONFIG** command or **CANCONFIG** command clears the commanded address; the Address Claim procedure will be executed again based on parameters specified in the **J1939CONFIG** command.

4.3 SMART2 NMEA2000 Logging

All NMEA2000 logs are configured using the **LOG** command, where the COM port is a CAN port (CCOM).

To enable NMEA2000 logs:

1. Configure the CAN bus. See *Configuring the CAN Bus* on page 37.
2. Enable the desired NMEA2000 logs.

NMEA2000 logs can be requested regardless of the on/off bus status of the receiver or the J1939 configuration. They are output if and only if the receiver is online.



The position for the **PGN129025**, **PGN129027** and **PGN129029** logs are reported in the user selected datum. See the **OUTPUTDATUM** command for more details.



When the solution type is INS (SPAN models), the DOPs in the PGN129029 message are calculated at a 1 Hz rate.
To determine if the receiver is providing an INS solution, check the **pos type** field in the **BESTPOS** log.

4.3.1 How to Configure CAN1 to Transmit NMEA2000 Messages

1. Enter the follow to configure CAN1:

```
CANCONFIG CAN1 ON 500K
```
2. Enter the following to request NMEA2000 logs:

```
LOG CCOM1 PGN129029B ONTIME 1
LOG CCOM1 PGN129025B ONTIME 0.1
LOG CCOM1 PGN129026B ONTIME 0.1
LOG CCOM1 PGN129027B ONTIME 0.1
```

Chapter 5 Built-In Status Tests

The Built-In Status Test monitors system performance and status to ensure the receiver is operating within specifications. The test detects an exceptional condition and informs the user through one or more indicators. The receiver status system is used to configure and monitor the indicators:

1. Receiver status word (included in the header of every message)
2. RXSTATUSEVENT log
3. RXSTATUS log

When a fatal event occurs (for example, a receiver hardware failure), a bit is set in the receiver error word, part of the **RXSTATUS** log, to indicate the cause of the problem. An **RXSTATUSEVENT** log is generated on all ports to show the cause of the error. Receiver tracking is disabled but command and log processing continues to allow error diagnosis. Even if the source of the error is corrected, the receiver must be reset to resume normal operation.

5.1 RXSTATUSEVENT Log

The **RXSTATUSEVENT** log is used to output event messages, as indicated in the **RXSTATUS** log.

On start up, the SMART2 is set to log **RXSTATUSEVENTA ONNEW** on all ports. You can remove this message using the **UNLOG** command.

Refer to the **RXSTATUSEVENT** log in the [Agriculture Commands and Logs Reference Manual](#) for log and command details. for a more detailed description of this log.

5.2 RXSTATUS Log

The Receiver Status log (RXSTATUS) provides system status and configuration information in a series of hexadecimal words.

5.2.1 Status Word

The status word is the third field after the header, as shown in the example in *Figure 11: Location of Receiver Status Word* below.

Figure 11: Location of Receiver Status Word

```
<RXSTATUS COM1 0 92.0 UNKNOWN 0 154.604 005c0020 643c 1899
< 00000022 5
< 005c0020 00000000 00000000 00000000
< 00000087 00000008 00000000 00000000
< 00000000 00000000 00000000 00000000
< 00000000 00000000 00000000 00000000
< 00000000 00000000 00000000 00000000
```

Receiver Status Word

Each bit in the status word indicates the status of a specific receiver condition or function. If the status word is 00000000, the receiver is operating normally. The numbering of the bits is shown in *Figure 12: Reading the Bits in the Receiver Status Word* on the next page.

Figure 12: Reading the Bits in the Receiver Status Word

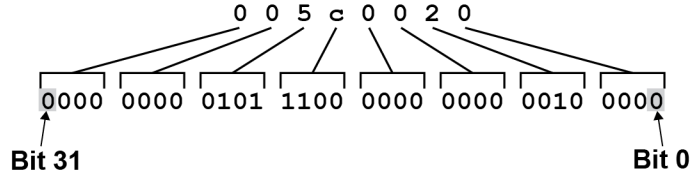

If the receiver status word indicates a problem, see *Examining the RXSTATUS Log* on page 44.

5.2.2 Error Word

The error field contains a 32-bit word. Each bit in the word is used to indicate an error condition. Error conditions may result in damage to the hardware or erroneous data, so the receiver is put into an error state. If any bit in the error word is set, the receiver broadcasts the **RXSTATUSEVENT** log on all ports (unless the user has unlogged it), idles all channels, turns the antenna off and disables the RF hardware. To override the error state, reset the receiver.

The receiver can be configured to generate event messages triggered by status conditions. Receiver Error words automatically generate event messages. These event messages are output in the **RXSTATUSEVENT** log (see also *Set and Clear Mask for all Status Code Arrays* on the next page).

The error word is the first field after the log header in the **RXSTATUS** log, as shown in the example in *Figure 13: Location of Receiver Error Word* below.

Figure 13: Location of Receiver Error Word

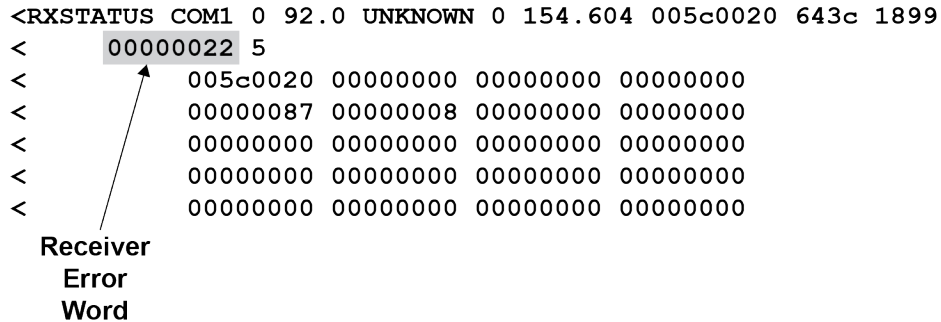
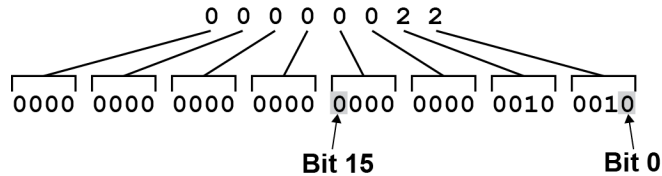

Figure 14: Reading the Bits in the Receiver Error Word below shows an example of a receiver error word.

Figure 14: Reading the Bits in the Receiver Error Word



Refer to the **RXSTATUS** log and **RXSTATUSEVENT** log for more detailed log descriptions. If the receiver error word indicates an error, refer to *Examining the RXSTATUS Log* on page 44.

5.2.3 Status Code Arrays

There are currently 5 status code arrays:

- receiver status word
- auxiliary 1 status

- auxiliary 2 status
- auxiliary 3 status
- auxiliary 4 status

Each status code array consists of four 32-bit words (the status word, a priority mask, a set mask and a clear mask). The status word is similar to the error word, with each of the 32 bits indicating a condition. The priority mask words are used to modify the behavior caused by a change in one of the bits in the associated status words. Each bit, in any mask, operates on the bit in the same position in the status word. For example, setting bit 3 in the priority mask changes the priority of bit 3 in the status word.

Figure 15: Status Code Arrays

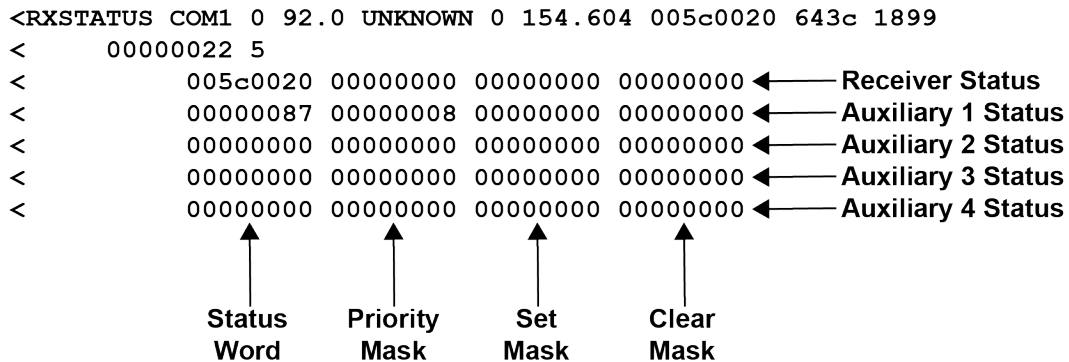

5.2.4 Receiver Status Code

The receiver status word is included in the header of all logs. It has 32 bits that indicate certain receiver conditions. If any of these conditions occur, a bit in the status word is set. Unlike the error word bits, the receiver continues to operate, unless the priority mask for the bit has been set. The priority mask bit changes the bit in the receiver status word into an error bit. Anything that results from an error bit becoming active also occurs if a receiver status and its associated priority mask bits are set.

5.2.5 Auxiliary Status Codes

The auxiliary status codes are only in the **RXSTATUS** log. The four arrays that represent the auxiliary status codes indicate the receiver state for information purposes only. The events represented by these bits typically do not cause receiver performance degradation. The priority mask for the auxiliary codes does not put the receiver into an error state. Setting a bit in the auxiliary priority mask results in the corresponding bit in the receiver status code to be set if any masked auxiliary bit is set. Bit 31 of the receiver status word indicates the condition of all masked bits in the auxiliary 1 status word. Likewise, bit 30 of the receiver status word corresponds to the auxiliary 2 status word and bit 29 to the auxiliary 3 status word.

Refer also to the **RXSTATUS** log for a more detailed description.

5.2.6 Set and Clear Mask for all Status Code Arrays

The other two mask words in the status code arrays operate on the associated status word in the same way. These mask words are used to configure the bits in the status word that result in a **RXSTATUSEVENT** log broadcast. The set mask is used to turn logging on temporarily while the bit changes from the 0 to 1 state. The clear mask is used to turn logging on temporarily while the bit changes from a 1 to a 0 state. Note the error word does not have any associated mask words. Any bit set in the error word results in a **RXSTATUSEVENT** log broadcast (unless unlogged).

Refer also to the **RXSTATUS** log for a more detailed description.

Chapter 6 Troubleshooting

There are simple ways to diagnose and resolve problems. In many cases, the issue can be resolved within a few minutes, avoiding the inconvenience and loss of productivity that results from having to return the receiver for repair. This section discusses troubleshooting issues and includes cross-references to other sections of the manual that may help resolve problems.

If unsure of the symptoms or if the symptoms do not match any of those listed, use the RXSTATUS log to check the receiver status and error words. See *Examining the RXSTATUS Log* on the next page.

Try to resolve the problem using the troubleshooting guide in *Table 9: Troubleshooting Based on Symptoms* below, then try our Knowledge Base at novatel.com/support. If you are still not able to resolve the problem, see *Customer Support* on page 10 for troubleshooting logs and contact information.

Table 9: Troubleshooting Based on Symptoms

Symptom	Related Section
The receiver is not properly powered	Check the power cable. Replace if faulty. See <i>Power Supply Requirements for the SMART2</i> on page 20
The receiver cannot establish communication	Check the serial cables and ports. Replace if faulty. See <i>SMART2 CAN Bus</i> on page 36. Refer also to the SERIALCONFIG command.
The receiver is not tracking satellites	Ensure that the antenna has an unobstructed view of the sky from horizon to horizon. Check the RXSTATUS error states. See <i>Examining the RXSTATUS Log</i> on the next page. If the receiver is in error mode, it does not track. Use the Interference Toolkit to check if there is an interference signal present. Go to the Interference Toolkit section in the NovAtel Documentation portal: docs.novatel.com/OEM7 .
No data is being logged	Refer to <i>SMART2 CAN Bus</i> on page 36 and <i>Communications with the Receiver</i> on page 23
Random data is being output by the receiver or binary data is streaming	Check the baud rate on the receiver and in the communication software. Refer to the SERIALCONFIG command and FRESET command. See also <i>SMART2 CAN Bus</i> on page 36.
A command is not accepted by the receiver	Check for correct spelling and command syntax. See <i>Communications with the Receiver</i> on page 23 and refer to the FRESET command in the Agriculture Commands and Logs Reference Manual
There appears to be a problem with the receiver's memory	Refer to the NVMRESTORE command.

Symptom	Related Section
An environmental or memory failure. The receiver temperature is out of acceptable range or the internal thermometer is not working	<p>Move the receiver to within an acceptable temperature range. See:</p> <ul style="list-style-type: none"> • <i>High Temperature Environments</i> on page 48 • <i>SMART2 Environmental and Electrical Specifications</i> on page 69
Overload and overrun problems. Either the CPU or port buffers are overloaded	Reduce the amount of logging or increase the baud rate.
The receiver is indicating that an invalid authorization code has been used	Refer to the VERSION log or VALIDMODELS log and the MODEL command or AUTH command.
The receiver is being affected by jamming	Move the receiver away from any possible jamming sources
The receiver is being affected by interference	<p>Go to the Interference Toolkit section in the NovAtel Documentation portal: docs.novatel.com/OEM7.</p> <p>Move the GNSS antenna away from the source of the interference signal.</p> <p>If the interference mitigation feature is enabled on the receiver, configure a filter within the Interference Toolkit to filter out the interference signal.</p>
The receiver's Automatic Gain Control (AGC) is not working properly	See the jamming symptom in this table

For information about the commands and logs in this section, refer to the [Agriculture Commands and Logs Reference Manual](#).

6.1 Examining the RXSTATUS Log

The RXSTATUS log provides detailed status information about your receiver and can be used to diagnose problems. Refer to the **RXSTATUS** log for details on this log and on how to read the receiver error word and status word. *Table 10: Resolving a Receiver Error Word* below, *Table 11: Resolving an Error in the Receiver Status Word* on the next page and *Table 12: Resolving an Error in the AUX1 Status Word* on page 47 have actions to take when your receiver has an error flag in these words. If you are not able to resolve the condition, contact *Customer Support* on page 10.

Table 10: Resolving a Receiver Error Word

Bit Set	Action to Resolve
0-2	Issue a FRESET command (for bit 1, reload new firmware).
4	Contact <i>Customer Support</i> on page 10.
5	Check the VERSION log. The VERSION log will indicate "Invalid authcode". Upgrade the auth-code as described in <i>Upgrading Using an Auth-Code</i> on page 61.
6	Issue a FRESET command

Bit Set	Action to Resolve
7	See <i>Power Supply Requirements for the SMART2</i> on page 20
8	Reserved
9	<p>Check the temperature ranges in:</p> <ul style="list-style-type: none"> <i>SMART2 Environmental and Electrical Specifications</i> on page 69 <div style="border: 1px solid black; padding: 10px; margin-top: 10px;">  <p>The operating temperatures are ambient air temperatures. The temperature sensors on the receiver PCB will reflect higher operating temperatures (refer to the HWMONITOR log). The PCB temperature sensors will trigger a receiver warning and receiver error at 100°C and 110°C respectively. The warning and error conditions are captured using the RXSTATUS log.</p> </div>
10	Possible hardware or environmental condition. If you cannot resolve the problem, contact <i>Customer Support</i> on page 10.
11	<p>Possible hardware or environmental condition. If you cannot resolve the problem, contact <i>Customer Support</i> on page 10.</p> <p>Also, check the Auxiliary 2 Status word to determine which PLL is in error.</p>
12-14	Reserved
15	Issue a FRESET command and power cycle the unit. If the bit is still present, contact <i>Customer Support</i> on page 10.
16	Monitor CPU idle time. Reduce number of logs or the rate of data logging.
17	Ensure that the Version log is consistent with the hardware.
18-19	Reserved
20	SoftLoad is in progress. See <i>Updating Using SoftLoad Commands</i> on page 56.
21	You may be exceeding the receiver's velocity limit. If so, reduce velocity. This error can only be cleared by resetting the receiver.
22	Reload firmware using WinLoad or the SoftLoad commands.
23-30	Reserved
31	Possible hardware failure. Contact <i>Customer Support</i> on page 10.

Table 11: Resolving an Error in the Receiver Status Word

Bit Set	Action to Resolve
0	Check the Error Word in the RXSTATUS log. See also <i>Table 10: Resolving a Receiver Error Word</i> on the previous page

Bit Set	Action to Resolve
1	Check the temperature ranges in <ul style="list-style-type: none"> • <i>SMART2 Environmental and Electrical Specifications</i> on page 69
2	See <i>Power Supply Requirements for the SMART2</i> on page 20
3	For SMART Antennas, contact <i>Customer Support</i> on page 10
4	
5	
6	
7	Check the CPU idle time. Check for unnecessary logging. Check for simultaneous use of functionality.
8	See <i>Table 7: Serial Ports Supported</i> on page 24 Also, check the Auxiliary 2 Status word to determine which COM port has overrun its buffer.
9-11	Reserved
15	Check the Auxiliary 1 status word to determine which RF channels are jammed.
16-17	Reserved
18	When the receiver has tracked GNSS satellites long enough for a valid almanac to be received, this bit will be set to 0.
19	None. This bit only indicates if the receiver has calculated a position.
20	None. This bit is a status bit indicating if the receiver's position has been manually fixed and does not represent a problem. Refer also to the FIX command.
21	None. This bit indicates if clock steering has been manually disabled. Refer also to the FRESET command.
22	None. This bit only indicates if the clock model is valid. Refer also to the FRESET command.
23	None. This bit indicates if the phase-lock-loop is locked when using an external oscillator. Refer also to the FRESET command.
24	Check the CPU idle time. Check for unnecessary logging. Check for simultaneous use of functionality.
25-26	None. These bits identify the receiver family. For SMART2, bit 25 is set to 1 and bit 26 is set to zero.
27	Interference Toolkit HDR mode status. When this bit is set to 1, Interference Toolkit HDR mode is enabled.
28	Digital filter status. When this bit is set to 1, an Interference Toolkit digital filter is enabled.
29	None. This bit indicates if any bits in the auxiliary 3 status word are set. The auxiliary 3 word provides status information and does not contain any new information on problems. Refer also to the FRESET command.

Bit Set	Action to Resolve
30	None. This bit indicates if any bits in the auxiliary 2 status word are set. The auxiliary 2 word provides status information and does not contain any new information on problems. Refer also to the FRESET command.
31	None. This bit indicates if any bits in the auxiliary 1 status word are set. The auxiliary 1 word provides status information and does not contain any new information on problems. Refer also to the FRESET command.

For information about the commands and logs in this section, refer to the [Agriculture Commands and Logs Reference Manual](#).

6.2 Examining the AUX1 Status Word

Table 12: *Resolving an Error in the AUX1 Status Word* below provides actions to take when your receiver has an error flag in the AUX1 status word.

Table 12: Resolving an Error in the AUX1 Status Word

Bit Set	Action to Resolve
0-2	Jammer detected
3	None. This bit indicates that Position Averaging is ON
4-6	Jammer detected
7	(Reserved bit)
8-10	(Reserved bits)
11	(Reserved bit)
12	None. This bit indicates a Profile set using the PROFILE command is activated.
13	Throttled Ethernet Reception Check for unusually high Ethernet traffic being directed to the Receiver. This does not represent an error condition on the receiver, but suggests there may be an issue in the network environment on the receiver.
14-17	AGC error on RF1 through RF4 respectively.. Contact NovAtel <i>Customer Support</i> on page 10 for additional information.
18	Connect the receiver via Ethernet.
19-21	Reduce the amount of logging on the Ethernet ports
22-24	Reduce the amount of logging on the NTRIP ports
25-27	Reduce the amount of logging on the Virtual COM ports
28-29	AGC error on RF5 (bit 28) or RF6 (bit 29).. Contact NovAtel <i>Customer Support</i> on page 10. for additional information.
30-31	(Reserved bits)

6.3 High Temperature Environments

The operating temperature of SMART2 increases as more features (channels used, HDR mode, etc.) are enabled.

When the receiver is operating in an environment that is near its maximum ambient temperature, an increase in the ambient air temperature or enabling additional features may cause the receiver to exceed its maximum operating temperature and generate a Temperature Status error. When a Temperature Status error occurs, the receiver idles all channels, turns off the antenna and disables the RF hardware. The communication interfaces continue to function so commands can be sent and logs received.

6.3.1 Indicators of an Error State

The indications that the receiver is in an error state, such as a Temperature Status error, are:

- Logs that have a solution status will show INSUFFICIENT_OBS as the Solution Status.
- The **RXSTATUSEVENT** log is output on all communication ports. This log will indicate an error condition in the Receiver Error word of the log.
- All logs output have Bit 0 set in the Receiver Status word of the log header.

To determine the cause of the error, log the **RXSTATUS** log and check the Receiver Error word. If Bit 9 is set, it is a Temperature Status error. For information about reading the Error Word, refer to *Error Word* on page 41.

6.3.2 Recovering from a Temperature Status Error

The receiver must be reset or power cycled to recover from a receiver error such as a Temperature Status error.

Log information is lost when the receiver is reset. Therefore, any logs required to identify and troubleshoot the error, such as the **RXSTATUS** log, should be collected before resetting the receiver.

Also, steps should be taken to reduce the cause of the receiver temperature error to prevent the error from occurring again. See *Mitigating High Receiver Temperature* below.

6.3.3 Mitigating High Receiver Temperature

If the receiver has a high temperature warning or error, use one or more of the following suggestions to reduce the receiver temperature.

- If possible, reduce the ambient temperature around the receiver or move the receiver to an area with a lower ambient temperature.
- Disable the receiver features that are not required for the current operation of the receiver.

6.3.4 Monitoring the Receiver Temperature

If the receiver is operating in a high ambient temperature environment, you can monitor the receiver temperature using the **RXSTATUS** and **HWMONITOR** logs.

1. Log the **RXSTATUS** log and check Bit 1 of the Receiver Status word.

```
LOG RXSTATUS onchanged
<RXSTATUS USB1 0 81.5 FINESTEERING 1990 326146.020 0a104020 2ae1 14434
< 00000000 5
< 0a104020 00000000 00030000 00030000 (Receiver Status)
< 00062000 00001008 00000000 00000000
< 00000000 00000000 80000000 00000000
< 80000000 00000000 00000000 00000000
< 00000000 00000000 00000000 00000000
```

For information about reading the Receiver Status word, refer to *Status Word* on page 40.

- If Bit 1 is 0, the temperature is okay. Continue monitoring, but no action is required.

If Bit 1 is 1, the receiver temperature has exceeded the warning limit.

- Log the **HWMONITOR** log and check the two temperature status fields (0x01 and 0x16).

```
LOG HWMONITOR ontime 30
<HWMONITOR USB1 0 77.5 FINESTEERING 1990 326851.000 0a104020 52db 14434
< 10
<      58.424915314 100 (Temperature 0x01)
<      0.000122100 200
<      3.296703339 600
<      5.169230938 700
<      1.192307711 800
<      3.300366402 f00
<      1.833943844 1100
<      5.159462929 1500
<      1.555555582 1700
<      58.485961914 1600 (Temperature 0x16)
```

Pay attention to the reading and the boundary limit status.

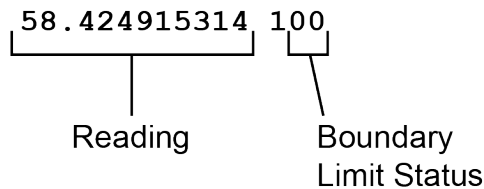

Refer to Table: HWMONITOR Status Table in the **HWMONITOR** log section for a description of the Boundary Limit Status.

- Use the suggestions in *Mitigating High Receiver Temperature* on the previous page to reduce the receiver temperature.
- Continue monitoring the **HWMONITOR** log to see if receiver temperature is dropping.
- Check the **RXSTATUS** log to see if the temperature status changes to Okay (Bit 1 in the Receiver Status word changes to 0).

6.4 Safe Mode

Safe Mode is an error condition triggered on the SMART2 if it encounters certain critical problems during start-up. The receiver does not track GNSS satellites in this state, but the user interface is still available to allow for diagnosis of the problem.

The receiver will enter Safe Mode under certain rare cases including the following:

- Corrupted or bad data within the receiver Non-Volatile Memory (NVM).
- An unsupported Auth Code.
- The expected main firmware image could not be found by the boot code. This is possibly due to an error during the main firmware loading process (i.e. WinLoad, SoftLoad, etc.).

Safe Mode exists to allow users to take steps to recover the receiver after such an error occurs. Potential recovery steps are described in *Recovery Steps* on the next page.

Safe Mode is indicated by an error bit in the **RXSTATUS** log.

6.4.1 *Reset Loop Detection*

In order to determine when the Safe Mode error should be triggered, the SMART2 has the ability to detect when an unexpected reset has occurred during the boot process. If a Reset Loop is detected, the **Reset Loop Detected** bit is set in the **RXSTATUS** log.

This bit is only a warning and the receiver may still be able to operate correctly. The receiver will allow several unexpected resets to occur before triggering the Safe Mode Error, at which point the receiver will not track GNSS satellites.

6.4.2 *Recovery Steps*

If the **Safe Mode** error bit or the **Reset Loop Detected** warning bit are set in the **RXSTATUS** log, take the following steps to diagnose and recover the system:

1. Request the **SAFEMODESTATUS** log and determine the current *Safe Mode State* of the system.
2. Reference Table: Safe Mode States and find the suggested actions for the current Safe Mode State.
3. If the suggested actions do not resolve the issue, contact NovAtel Customer Support.

Chapter 7 NovAtel Firmware and Software

Download the most recent versions of the NovAtel firmware and receiver software from the Downloads section of novatel.com/support.

NovAtel Software

NovAtel software applications run on a computer and are used to interact with NovAtel receivers. The following software is available from the NovAtel website:

- NovAtel Application Suite (a GUI interface)
- Convert (converts receiver data logs into different formats)

NovAtel software is available in Windows compatible and Unix compatible versions. For information about using NovAtel Application Suite, refer to docs.novatel.com/Tools. For information about Convert, refer to the help system available within the application.

NovAtel Firmware

NovAtel firmware runs on NovAtel receivers. It provides the features and functionality available on the receiver.

The firmware download file contains:

- Firmware *.shex file
- WinLoad software utility

7.1 Firmware Updates and Model Upgrades

A local NovAtel dealer can provide all the information needed to upgrade or update a receiver. Refer to novatel.com/contactus/sales-offices for contact information or contact sales.nov.ap@hexagon.com or support.novatel@hexagon.com directly.

7.1.1 Firmware Updates

Firmware updates are firmware releases that include fixes and enhancements to the receiver functionality. Firmware updates are released on the NovAtel web site as they become available. Firmware upgrades can be performed using the WinLoad utility, SoftLoad commands, NovAtel Application Suite or with a custom loader application. Contact NovAtel Customer Support (support.novatel@hexagon.com) for details on custom loader requirements.

7.1.2 Model Upgrades

Model upgrades enable purchased receiver features.

Contact a local NovAtel dealer to assist in selecting the upgrade options that best suit your GNSS needs at novatel.com/contactus/dealer-network. Contact NovAtel Customer Support novatel.com/support or novatel.com/contactus/sales-offices to request a temporary upgrade authorization code for trial purposes.

Model upgrades can be applied to the receiver with an authorization code and the **AUTH** command without returning the receiver to the dealer.

7.2 Authorization Code

An authorization code, commonly known as an auth-code, is required to upgrade a SMART2. Auth-codes are obtained by contacting novatel.com/support. Upon contact, NovAtel Customer Support requires:

- the receiver model number
- the receiver serial number
- the receiver firmware version

Enter the **LOG VERSION** command to determine the receiver model, serial number and firmware version.

Example:

```

ENTER → MODEL NUMBER          SERIAL NUMBER          FIRMWARE VERSION
GPSCARD "DDNLTNNTMNG" "BMSB19050039F" "OEM2500-1.00" "OA7CR0602RN0000"
                                     |         |         |
                                     |         |         |
                                     PRODUCT FIRMWARE RELEASE
                                     FAMILY  NUMBER  INDICATOR

```

After determining the appropriate model and firmware version, the authorization code (auth-code) is issued. The auth-code is required to unlock the features on the new model type.

To upgrade to a new model with the same firmware version, use the **AUTH** command with the issued auth-code, as outlined in *Upgrading Using an Auth-Code* on page 61.

To upgrade to a new model with a new firmware version, the new firmware needs to be loaded into the SMART2. For instructions, refer to *Updating or Upgrading Using the WinLoad Utility* on the next page, *Updating the Firmware Using NovAtel Application Suite* on page 55 or *Updating Using SoftLoad Commands* on page 56.

Auth-codes work with any signed firmware image. Therefore, if a receiver has an auth-code for the old version of firmware, that same auth-code will work for the new version of firmware, provided both images are digitally signed by NovAtel.

Signed firmware images are distributed in *.shex files. The new download package includes a signed firmware file type that uses an extension designated as ".shex" (example ES7PR0602RN0000.shex), as well as the latest WinLoad utility and What's New file containing firmware update change details.

Temporary auth-codes may be provided by NovAtel for evaluation purposes. Once the trial period has expired, the functionality provided by the auth-code is removed. The expiration date for temporary auth-codes is in the form YYMMDD, where YY = year, MM = month and DD = day. The date is the last day that the auth-code is valid and expires at the end of day, UTC time.

Once the trial period has expired, a new auth-code will need to be obtained from NovAtel Customer Support (support.novatel@hexagon.com).

Firmware images may also have auth-codes embedded within them. The models provided by such firmware images will be valid only on receivers with certain PSNs and Hardware Versions.

7.3 Downloading Firmware Files

To proceed with an update or possibly an upgrade, obtain the latest version of firmware by downloading the firmware file for your product from novatel.com/support/support-materials/firmware-download.



If the receiver is an H-model, do not use the firmware available from the web site. Contact *Customer Support* on page 10 to obtain the correct firmware.

7.3.1 Format of Firmware Files

All of the firmware available on the downloads website are packaged in .zip files with the following name:

- 2XXXX Firmware.zip for firmware to be installed on SMART2 receivers

For convenience, unzip the update file to a GNSS sub-directory (for example, C:\GNSS\LOADER). If the firmware update file is password protected, NovAtel Customer Support provides the required password.

The zip archive includes the following files:

winload.exe	WinLoad utility program
howto.txt	Instructions on how to use the WinLoad utility
whatsnew.rtf	Information on the changes made in the firmware since the last revision
x..x.shex	Firmware version upgrade file, where x..x defines the product name and release (e.g., ES2PR0602RN0000.shex)
NovAtel Software License Agreement.rtf	License agreement for the firmware



NovAtel has an online video tutorial that explains firmware updating at: novatel.com/support/support-materials/novatel-video.

7.4 Updating or Upgrading Using the WinLoad Utility

WinLoad is a utility used to update or upgrade a SMART2. To use WinLoad, the receiver must be connected to the computer running WinLoad using a serial port (COM port) connection.

7.4.1 Using the WinLoad Utility

If opening WinLoad for the first time, ensure the file and communications settings are correct.

Open a File to Download

Select File | File Open. Navigate to the file to open (*Figure 16: WinLoad's Open Window* below).

Figure 16: WinLoad's Open Window

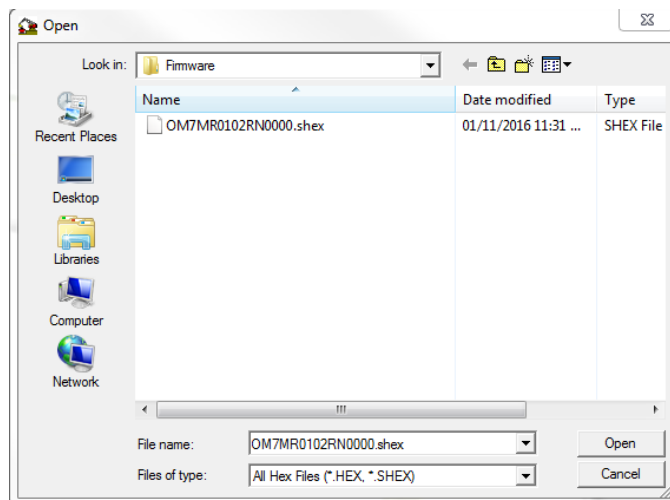

When a file is selected, the *filename* appears in the main WinLoad display area and in the title bar (*Figure 17: Open File in WinLoad* on the next page).

Figure 17: Open File in WinLoad

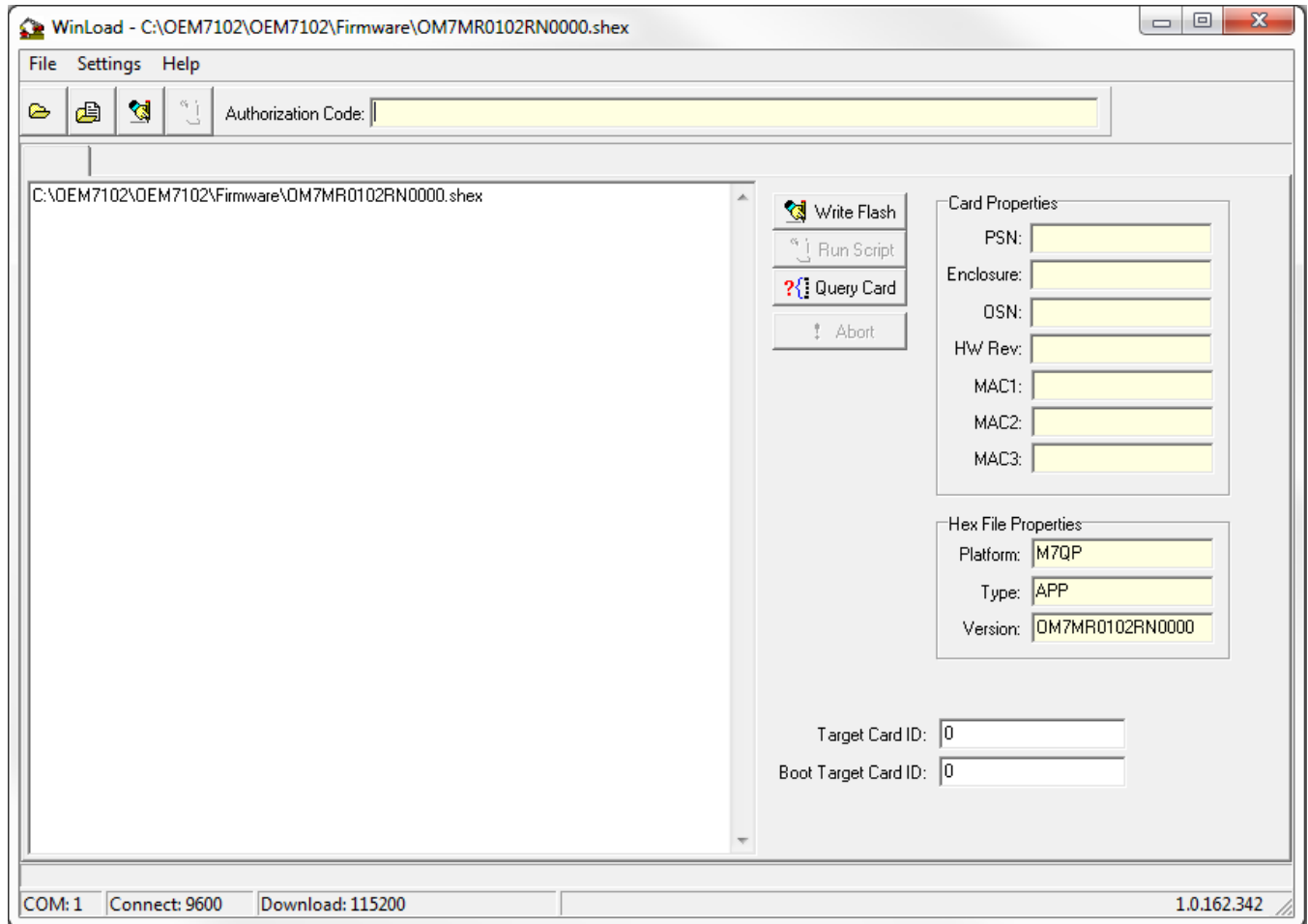

Communications Settings

To set the communications port and baud rate, select Settings | COM Settings. Choose the computer port to use from the Com Port drop down list and the baud rate from the Download Baudrate drop down list. Set the baud rate as high as possible (the default of 115200 is preferred if a higher baud rate is not available).

Figure 18: COM Port Setup

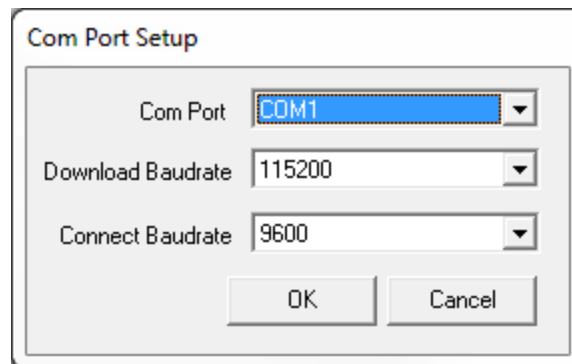

Downloading Firmware

1. Select the file to download according to *Open a File to Download* on page 53.
2. Ensure the file path and name are displayed in main display area (see *Figure 17: Open File in WinLoad* on the previous page).
3. Click **Write Flash** to download the firmware.
4. When *Searching for card* appears in the main display, power cycle the receiver.
5. If the Authorization Code window appears, enter the auth-code and click **OK**. See *Authorization Code* on page 51 for further information about the Authorization Code.
6. The receiver finishes the download and then resets. The process is complete when *Done* appears in the main display area.
7. Close WinLoad.



If loading a firmware that is currently installed on a SMART2 (i.e. reloading the same version of firmware on a receiver), ensure that *Optimized Loading* option is unchecked in WinLoad under *Settings | Options | Optimized Loading*.

7.5 Updating the Firmware Using NovAtel Application Suite

To use NovAtel Application Suite to update the receiver firmware, the receiver must be connected to the computer running NovAtel Application Suite using a serial (COM) port or Bluetooth port.

To update the firmware on the receiver:

1. Obtain the new firmware file.

See *Downloading Firmware Files* on page 52 for information about obtaining the latest version of receiver firmware.



Copy the firmware file to the computer's local drive before uploading.

2. Connect a computer to the receiver using a serial (COM) cable, USB cable or Ethernet connection.
3. Start NovAtel Application Suite on the computer.
4. Use NovAtel Application Suite to connect to the receiver.

For information about using NovAtel Application Suite, refer to docs.novatel.com/Tools.

5. On the *Status and Configuration* window, click the **Device** menu and select **Update**.

The *Update* window appears.

6. Click the **Browse** button.
7. Navigate to the directory that contains the new firmware file and select the file.
8. Click the **Open** button.

The Update window appears with the name of the selected file in the Select File field.

9. Click the **Apply** button.

After the new software is loaded, the receiver will restart.

7.6 Updating Using SoftLoad Commands

Firmware can be updated on a running receiver using a process called SoftLoad. Any available communication ports on the receiver (COM, USB, ICOM, etc.) can be used. The SoftLoad process is made up of a set of commands and logs that are used to send new firmware data to a receiver and check the progress of the update. Use SoftLoad if automated loading is desired or if a connection is only possible through USB or Ethernet.

The receiver stops tracking GNSS satellites during the SoftLoad process. Do not attempt to SoftLoad when GNSS satellite tracking on the unit is required. If the unit is connected to the NovAtel Connect utility, only the Console and ASCII Message windows may remain open in the Connect Utility.

7.6.1 SoftLoad Commands and Logs

Command	Description
SOFTLOADRESET	Initiate a new SoftLoad process
SOFTLOADSREC	Send an S-Record to the receiver for the SoftLoad process
SOFTLOADDATA	Send firmware image data to the receiver for the SoftLoad process
SOFTLOADCOMMIT	Complete the SoftLoad process
SOFTLOADSETUP	Send configuration information to the receiver for the SoftLoad process. This command is not required when working with a *.shex file
SOFTLOADFILE	Load a firmware image that has been loaded onto the internal storage of the receiver.

Log	Description
SOFTLOADSTATUS	Provides status updates for the ongoing SoftLoad process

Each command and log can be used in abbreviated ASCII, ASCII or binary format, with the exception of SOFTLOADDATA, which should only be used in binary format.

File Types

Firmware data is stored in *.shex files as ASCII data in the form of S-Records, based on the Motorola S-Record format. The *.shex file includes a digital signature for the firmware.

7.6.2 Working With S-Records

Each S-Record has a header indicating the type of information contained in the record.

Records beginning with S0, S5 and S7 contain metadata about the firmware image, such as version information and which card types are supported by the firmware image.

Example S0 Record

```
S0~V~OM7MR0400RN0000
```

Example S5 Records

```
S50000
```

```
S503D9FE25
```

```
S5033158D5A
```

Example S7 Records

```
S70000
S70500000000FA
```

Records beginning with S3 contain the actual firmware image data. Aside from the header, each pair of characters forms the ASCII representation of a binary byte. The format is as follows:

S3	LL	AAAAAAA	DDDDDDDD...DDDDDDDD	CC
		Check Sum		
		Little Endian Data. These bytes are copied into the "data" field of the SOFTLOADDATA command		
		4 - Byte Address. Set this as the value of "offset" in the SOFTLOADDATA command		
Length. This is the hexadecimal number of character pairs to follow in the record. This value minus 4 bytes for the address and 1 byte for the check sum is copied into the "data length" field of the SOFTLOADDATA command				
Header				

7.6.3 Sending Firmware Data

C++ source code is available to provide example code of processing S-Records and converting them to NovAtel format commands, as well as providing help with the SoftLoad process. Contact Customer Support at nova-tel.com/support and ask about the `srec2softload` utility.

The **SOFTLOADSREC** and **SOFTLOADDATA** commands can be used to send firmware data from *.shex files to the receiver.

S0, S5 and S7 S-Records should be sent directly to the receiver using the **SOFTLOADSREC** command, by enclosing the S-Record in quotation marks and issuing the command to the receiver, as follows:

```
SOFTLOADSREC "<S-RECORD>"
```

S3 records can be sent individually to the receiver using the **SOFTLOADSREC** command. Alternatively, the data from an S3 record can be parsed and packaged together with data from other S3 records into a binary **SOFTLOADDATA** command. Packaging data parsed from multiple S3 records into a binary **SOFTLOADDATA** command can result in improved firmware update times as each S3 record contains only a small number of bytes of firmware data. A single **SOFTLOADDATA** command can package up to 4096 bytes of firmware data from multiple S3 records, whereas a single **SOFTLOADSREC** command contains a maximum of 28 bytes of firmware data from a single S3 record.

Multiple S3 records can be packaged into a single **SOFTLOADDATA** command as long as the data from one S3 record follows immediately after the previous record. That is, the address from the current S3 record must equal the address from the previous S3 record plus the data length of the previous S3 record. If the data is not consecutive then the **SOFTLOADDATA** command can be sent with the amount of data it has packaged up to that point. Subsequent data can be packaged in a new **SOFTLOADDATA** command. Within the **SOFTLOADDATA** command, the "offset" field remains the address of the first S3 record and the "data" and "data length" are updated to include the new data.

The *.shex file data may contain many gaps and jumps. For example, in many NovAtel *.shex files, data for address 0x000_00000 is stored near the very end of the file.

Example Packaging Multiple S3 Records In A SOFTLOADDATA Command

Start a new **SOFTLOADDATA** command

```
S32100407AD48FCA63034B80F5CE0C36507DE3D8DCC0C6C0C00515D74BCACF2F2949E1
```

Address: 0x00407AD4 Num Data Bytes: 0x21 – 0x01 – 0x04 = 0x1C

```
S32100407AF04CCA4985F0F7B081E41D9B7D806C26989AE2D4E4CCBCB47C10FBFD3E43
```

Previous Address + Previous Num Bytes = 0x00407AD4 + 0x1C = 0x00407AF0

Address: 0x00407AF0 Num Data Bytes: 0x1C

Add data to existing **SOFTLOADDATA** command

```
S30D00407B0CDE0400A6374D5BFFC5
```

Previous Address + Previous Num Bytes = 0x00407AF0 + 0x1C = 0x00407B0C

Address: 0x00407B0C Num Data Bytes: 0x0D – 0x01 – 0x04 = 0x08

Add data to existing **SOFTLOADDATA** command

```
S3210000000007F0A7F1F4060000147B4000F49217813C7BB00014493F005C00000009
```

Previous Address + Previous Num Bytes = 0x00407B0C + 0x08 = 0x00407B14

Address: 0x00000000 Num Data Bytes: 0x1C

Requires new **SOFTLOADDATA** command because address does not match previous address + previous number of data bytes

Send existing **SOFTLOADDATA** command, and start a new **SOFTLOADDATA** command

```
S3210000001C80040000E001000030000000082B0100D8060000E4060000C806000063
```

Address: 0x0000001C Num Data Bytes: 0x1C

Previous Address + Previous Num Bytes = 0x00000000 + 0x1C = 0x0000001C

Add data to existing **SOFTLOADDATA** command

The **SOFTLOADDATA** command must be sent as a NovAtel binary format command.

7.6.4 SoftLoad Update Method

This section describes the sequence of commands that are issued to the receiver when updating using a *.shex file.



The response for each command must be processed before sending the next command so as to determine if the command was accepted or rejected, and to wait for the receiver to complete the operation.

Responses to SoftLoad commands are guaranteed to be output from the receiver within a specific time, which varies by command. Refer to specific SoftLoad command for more information on responses and the timeout values for SoftLoad commands.

1. Open a connection to any port on the receiver (COM, USB or ICOM) with the input and output INTERFACEMODE set to NOVATEL.
2. Request the SOFTLOADSTATUS log using the following command:

```
LOG SOFTLOADSTATUSA ONCHANGED
```
3. Initialize SoftLoad with a **SOFTLOADRESET** command. This command stops all tracking on the receiver to ensure sufficient memory is available for the loading process. An RXSTATUSEVENTA log reports a SoftLoad In Progress status.
4. Open the *.shex firmware file.
5. Read each line of the *.shex firmware file.
 - a. Send S0, S5 and S7 S-Records directly to the receiver using the **SOFTLOADSREC** command. The S-Record must be enclosed in quotation marks:

```
SOFTLOADSREC "<S-RECORD>"
```

Data within S0 records can also be sent to the receiver by converting them to **SOFTLOADSETUP** commands. Refer to the **SOFTLOADSETUP** command for details on how to convert from S0 S-Records to **SOFTLOADSETUP** commands.

- b. S3 S-Records should be parsed and packaged into a **SOFTLOADDATA** command.
6. Send the **SOFTLOADCOMMIT** command after all data from the *.shex file has been transferred to the receiver. The SOFTLOADSTATUS log reports the status of the loading process. Wait for a SOFTLOADSTATUS log to indicate the status is COMPLETE. The COMPLETE status or an error is guaranteed to be output from the receiver within 300 seconds from the time the **SOFTLOADCOMMIT** command was received by the receiver.
7. Send the auth code for the newly downloaded image using the **AUTH** command. This is only required if there is not already a signature auth code on the receiver as signature auth codes are maintained through a SoftLoad update. See *Authorization Code* on page 51 for details on Auth Codes.

```
AUTH ADD_DOWNLOAD <AUTH CODE>
```

8. Reset the receiver using any of the following methods:
 - Enter the **RESET** command
 - Enter the **FRESET** command
 - Power-cycle the receiver

Once the receiver resets, the new version of firmware is active.

The SoftLoad process can be safely canceled at any time using the **SOFTLOADRESET** command or by otherwise resetting the receiver. Once the COMPLETE status is reported by SOFTLOADSTATUS, the new firmware image will be run after the receiver is reset.

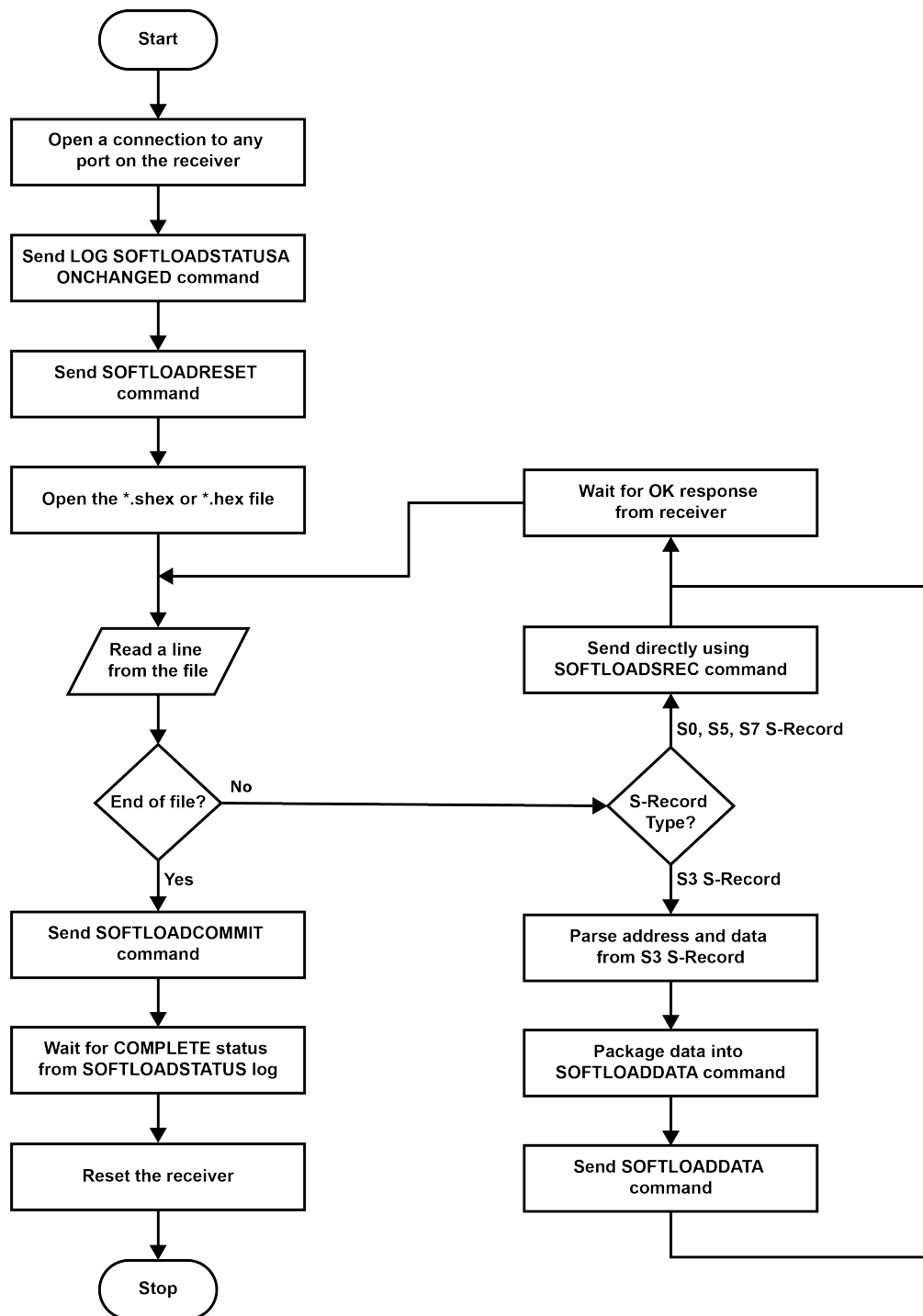

7.6.5 SoftLoad Errors

It is possible for errors to occur during the SoftLoad update. All command responses should be checked to verify all issued commands were accepted. The SoftLoad status should also be monitored in the SOFTLOADSTATUS log. Any status enum value greater than the ERROR status indicates an error has occurred during the SoftLoad update. In the event of an error, the SoftLoad update should be restarted by issuing a **SOFTLOADRESET** command or normal operation can be restored by resetting the receiver.

In rare cases after a SoftLoad error, the boot code may not be able to determine which is the latest firmware to be executed. To protect against this, SoftLoad does not erase the previous valid firmware image from flash on the

receiver. In such cases, the boot code will execute the old image and raise the "Safe Mode" error (see **RXSTATUS** log). If that error is detected, simply restart the SoftLoad process to reload the new firmware image and the error will be resolved.

7.7 Upgrading Using an Auth-Code

An authorization code (auth-code) enables (unlocks) model features.

An auth-code can be entered using NovAtel Application Suite, NovAtel Web UI or the command line interface.

7.7.1 Entering an Auth-Code Using NovAtel Application Suite

1. Obtain the new auth-code from NovAtel Sales or your local NovAtel dealer.
2. Connect a computer to the receiver using a serial (COM) cable, USB cable or Ethernet connection.
3. Start NovAtel Application Suite on the computer.
4. Use NovAtel Application Suite to connect to the receiver.

For information about using NovAtel Application Suite, refer to docs.novatel.com/Tools.

5. Click the **Device** menu and select **Details**.

The **Details** window appears.

6. On the *Authorizations* tile, enter the new Auth Code in the **Apply New Auth Code** box.
7. Click the **Apply** button to save the changes to the receiver.

The receiver will restart when a new Auth Code is applied.

7.7.2 Entering an Auth-Code Using the Command Line

The **AUTH** command is used to enter an auth-code. The upgrade can be performed directly through the NovAtel Application Suite command line or from any other communications program.



Refer to *Format of Firmware Files* on page 52 for details on updating versus upgrading.

1. Power up the SMART2 and establish communications.
2. Issue the **LOG VERSION** command to verify the current model, firmware version and serial number (refer to *Authorization Code* on page 51 for instructions on obtaining).
3. Issue the **AUTH** command, followed by the auth-code and model type (refer to *Authorization Code* on page 51 for details on obtaining any auth-code). The syntax is as follows:

```
auth <your auth-code here>
```

where **auth** is a command that enables model upgrades and auth-code is the upgrade authorization code, expressed as follows:

```
XXXXXX, XXXXXX, XXXXXX, XXXXXX, XXXXXX, MODEL, EXPDATE
```

where:

- Each X character is a case-insensitive ASCII character.
- The MODEL string is a maximum of 15 characters long and represents the model enabled by the auth-code.
- The EXPDATE string is the auth-code's expiry date, in YYMMDD format

Example:

```
auth 7WBMBK,887CB6,K5J3FH,5DF5P2,42PW8G,DSNLNNTMNG,121211
```

When the **AUTH** command is executed, the SMART2 reboots. Issuing the **LOG VERSION** command confirms the new upgrade model type and firmware version number.

If communicating using NovAtel Application Suite, the connection must be closed and reopened using the *Devices* window.

APPENDIX A SMART2 Technical Specifications

Table 13: SMART2 Physical Description

Size		81 H mm x Ø155 mm
Weight	SMART2	470 g
NovAtel Hardware Options	SMART2	-
	SMART2-B	-
	SMART2-TB	-

See the following sections for more information about the SMART2:

- *SMART2 Performance Specifications* on the next page
- *SMART2 Mechanical Specifications* on page 66
- *SMART2 Environmental and Electrical Specifications* on page 69
- *SMART2 Data Communication Specifications* on page 70
- *SMART2 Strobe Specifications* on page 71

A.1 SMART2 Performance Specifications

All specifications subject to GNSS system characteristics.

Table 14: SMART2 Receiver Performance

Horizontal Position Accuracy ¹		RMS	95%	
	Single Point L1 only	1.5 m	2.4 m	
	Single Point L1/L2	1.2 m	2.0 m	
	SBAS ²	0.6 m	0.9 m	
	DGPS	0.4 m	0.6 m	
	TerraStar-L ³	40 cm	50 cm	
	TerraStar-C PRO ³	2.5 cm	3 cm	
Pass to Pass Accuracy ²		RMS	95%	
	Single Point L1/L2 GLIDE	-	≤35 cm	
	TerraStar-L ³	-	≤15 cm	
	TerraStar-C PRO ³	-	2 cm	
Measurement Precision (RMS)		Code	Carrier	
	GPS	L1	4 cm	0.5 mm
		L2	8 cm	1.0 mm
	GLONASS	L1	15 cm	1.5 mm
		L2	8 cm	1.5 mm

¹Typical values. Performance specifications in open sky conditions and are subject to GPS system characteristics, US DOD operational degradation, ionospheric and tropospheric conditions, satellite geometry, baseline length, multipath effects and the presence of intentional or unintentional interference sources.

²GPS only.

³TerraStar subscriptions are available from NovAtel or TerraStar. RMS/95% accuracy under ideal conditions and may vary upon users geographic region, ionosphere activity, scintillation levels or unintentional interference sources.

Signals Tracked	GPS	L1, L2, L2C
	GLONASS (optional)	L1, L2
	BeiDou (optional)	B1I, B2I, B2b
	Galileo (optional)	E1 (optional), E5b (optional)
	SBAS	L1
	QZSS	L1, L2
Maximum Data Rate	Measurements	up to 20 Hz
	Position	up to 20 Hz
Time to First Fix	Hot: <35 s typical (Almanac and recent ephemeris saved and approximate position and time entered)	
	Cold: <50 s typical (No almanac or ephemeris and no approximate position or time)	
Signal Reacquisition	L1	0.5 s typical
	L2	<1.0 s typical
Time Accuracy ¹	20 ns RMS	
Velocity Accuracy ²	<0.055 m/s RMS	

¹Time accuracy does not include biases due to RF or antenna delay.

²Export licensing restricts operation to a maximum of 515 meters per second.

A.2 SMART2 Mechanical Specifications

Figure 19: SMART2 Dimensions

Note: Dimensions are in millimeters.

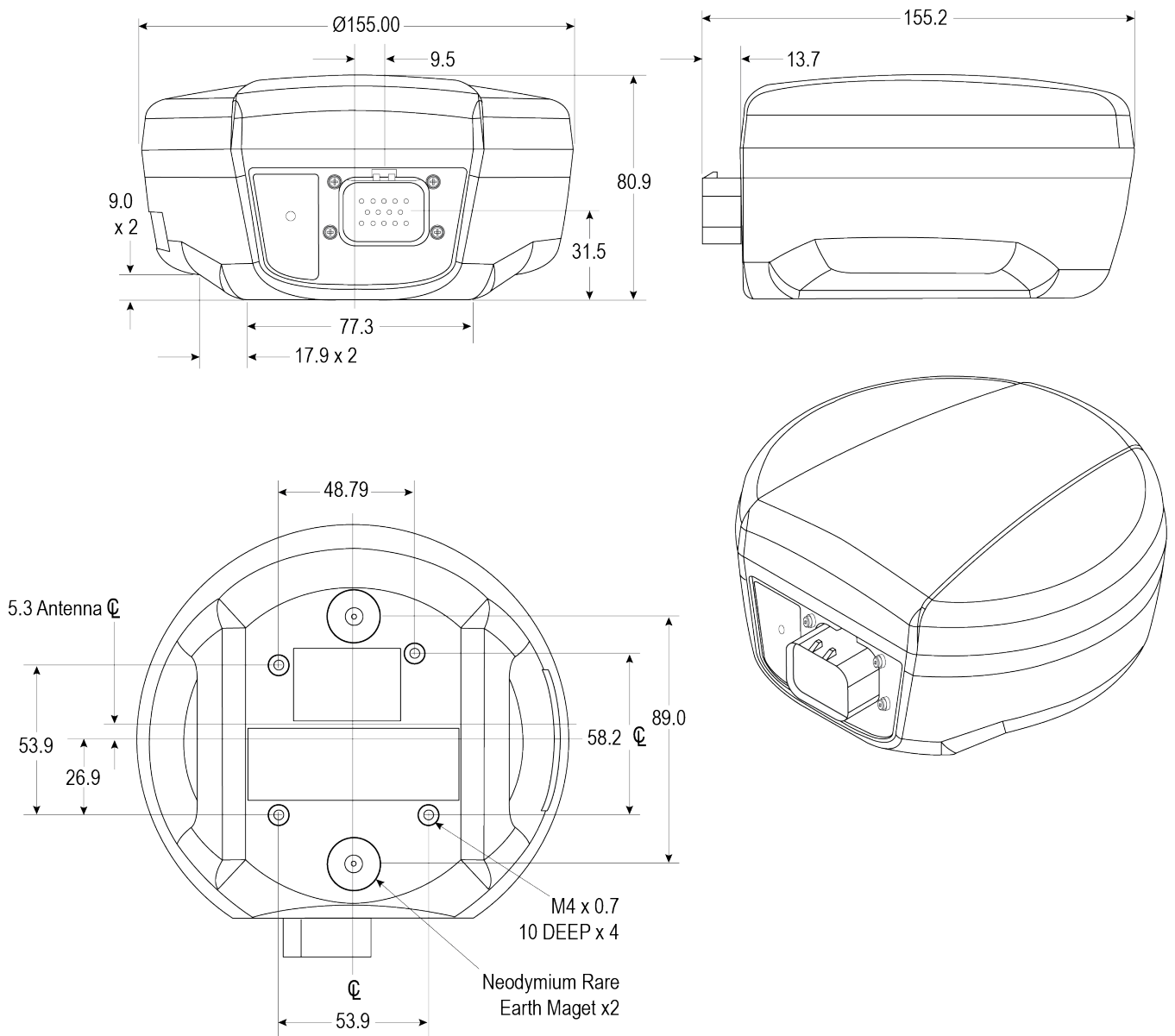

Figure 20: SMART2 Surface Mounting Plate (01018317)

Note: Dimensions are in inches.

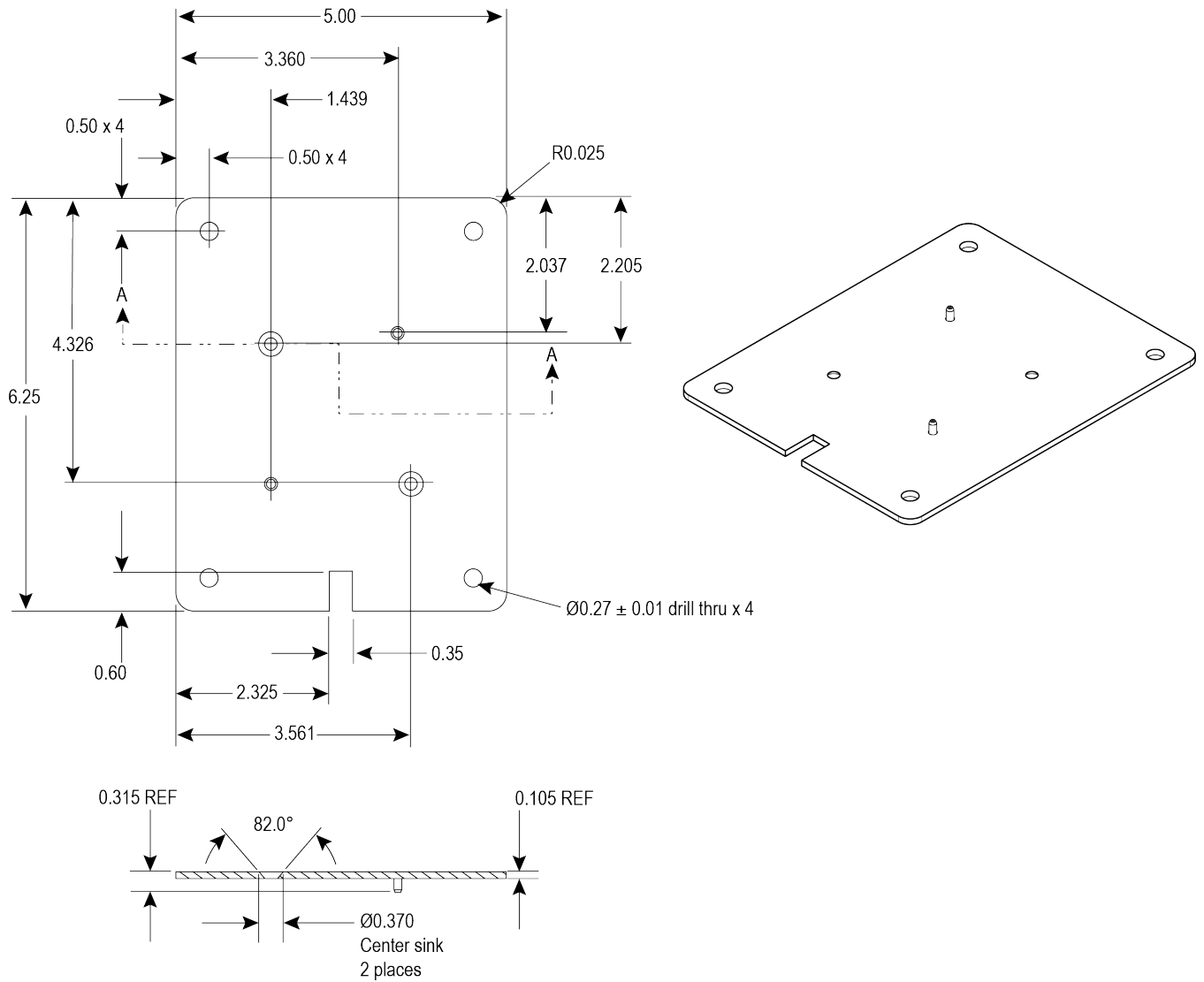
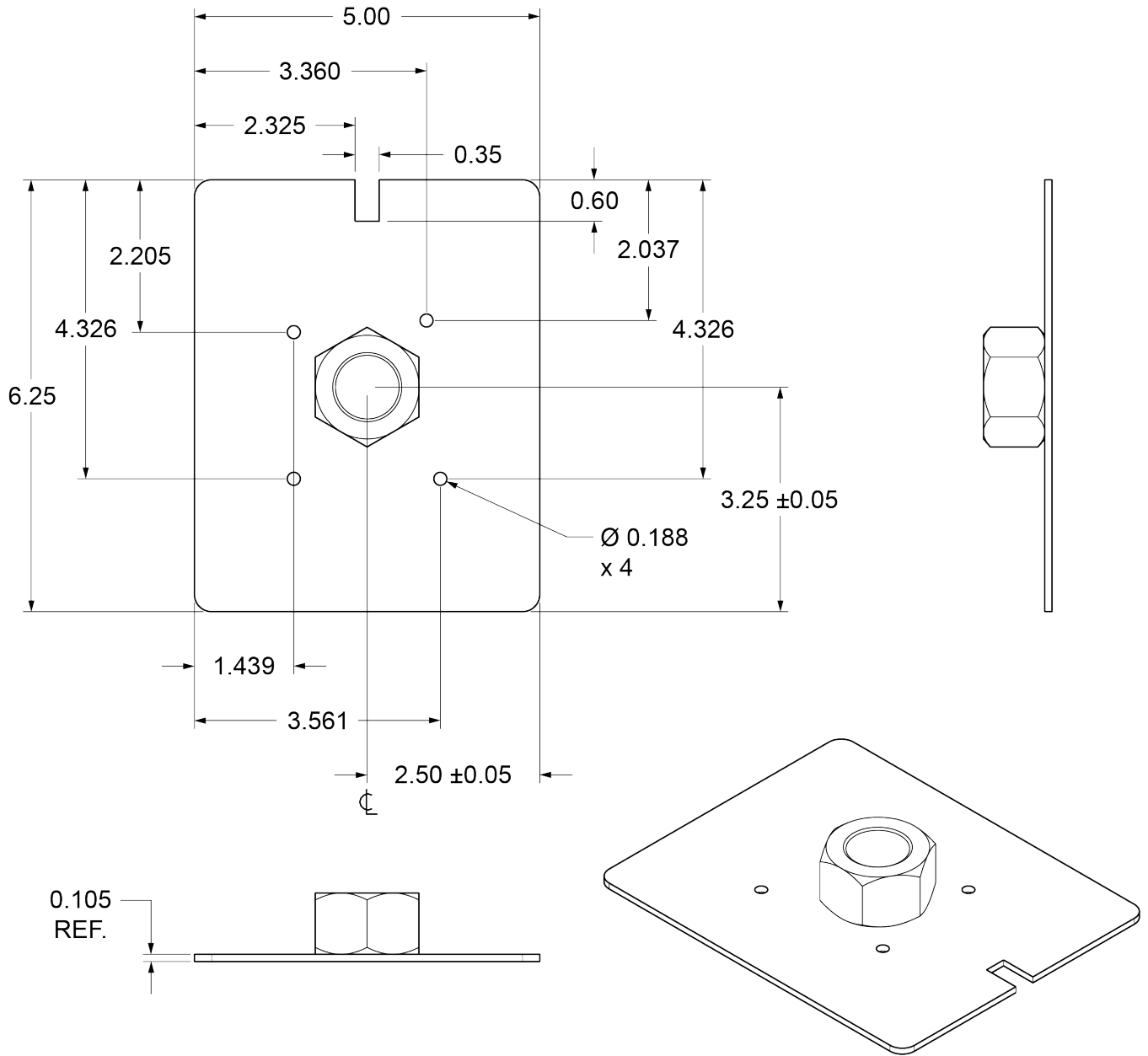

Figure 21: SMART2 Pole Mounting Plate (01019142)

Note: Dimensions are in inches.



A.3 SMART2 Environmental and Electrical Specifications



These specifications apply to the SMART2, SMART2-B and SMART2-TB.

Table 15: SMART2 Environmental Specifications

Operating Temperature	-40°C to +70°C
Storage Temperature	-45°C to +75°C
Humidity	MIL-STD-810G(CH1), Method 507.6
Immersion	MIL-STD-810G(CH1), Method 512.6
Ingress Protection Rating	IP67 and IP69 per IEC 60529 <div style="border: 1px solid black; padding: 5px; display: inline-block;">  IP67 and IP69 ratings require that the cable is connected to the SMART2. </div>
Shock	MIL-STD-810G(CH1), Method 516.7
Solar Radiation	IEC 60950-22 8.2 MIL-STD-810G(CH1), Method 505.6
Salt Fog	IEC 60950-22 8.3 MIL-STD-810G(CH1), Method 509.6
Sand and Dust	MIL-STD-810G(CH1), Method 510.6
Random Vibration	MIL-STD-810G(CH1), Method 514.7
Altitude	MIL-STD-810G(CH1), Method 500.6
Acidic Environment	MIL-STD-810G(CH1), Method 518.2
Contamination by Fluids	MIL-STD-810G, Method 504.2
Mechanical Bump	IEC 60068-2-27 Test Ea
Transit Drop (Packaged)	MIL-STD-810G(CH1), Method 516.7
Transit Drop (Unpackaged)	IEC 60068-2-31 Test Ec

Table 16: SMART2 Power Requirements

Voltage/Current	+7 to +30 VDC / 500 mA
Power Consumption	2.5 W typical, value for GPS L1/L2

A.4 SMART2 Data Communication Specifications

Table 17: Data Communications Interfaces

COM1, COM2, COM3	
Electrical format	RS-232
Data rates ¹	2400, 4800, 9600 (default), 19200, 38400, 57600, 115200, 230400 bit/s
Signals supported	COM1_Tx, COM1_Rx, COM2_Tx, COM2_Rx, COM3_Tx, COM3_Rx
SMART2 port	14-Pin Tyco Ampseal
CAN Bus	
Electrical Format	ISO 11898-2
Data rates	500 kbits/s maximum CAN Bus throughput is determined by slowest device on the bus
SMART2 port	14-Pin Tyco Ampseal
Bluetooth Hardware Option	
Protocol	Bluetooth Serial Port (SPP), Bluetooth version 4.0 (classic)
Security	Pin
Features Supported	Logs, Commands, NovAtel Connect (passive connection only)

¹Data rates higher than 115200 bit/s are not supported by standard PC hardware. Special PC hardware may be required for higher rates, including 230400 bit/s and 460800 bit/s.

A.5 SMART2 Strobe Specifications

The SMART2 strobe signals are available on the 14-Pin Interface connector. Pulse Per Second (PPS) strobes provide synchronization signal.



Refer to *SMART Antenna Interface Cable (Optional Accessory)* on the next page for pin out details.

Table 18: SMART2 Strobes Description

Strobes	Input/Output	Comment
Emulated Radar (ER)	Output	0VDC to VBATT+ Use the RADARCONFIG command to configure ER. Emulated Radar pulses are output through the <i>SMART Antenna Interface Cable (Optional Accessory)</i> on the next page and the RADARSTATUS log.
PPS	Output	3.3V CMOS A time synchronization output. This is a pulse where the leading edge is synchronized to receiver calculated GNSS Time. The polarity, period and pulse width can be configured using the PPSCONTROL command.
Mark Input (MKI) (Event1)	Input	Voltage Input Low is 0.8V Voltage Input High is 2V Input marks for which a pulse greater than 150 ns triggers certain logs to be generated. (Refer to the MARKPOS and MARK1TIME logs and ONMARK trigger.) Polarity is configurable using the EVENTINCONTROL command.

A.6 SMART Antenna Interface Cable (Optional Accessory)

The NovAtel part number for the SMART Antenna interface cable is 01019944. This cable provides access to all of the signals available on the SMART Antenna 14-pin Tyco Ampseal connector. The exposed wires (BATT+ and BATT-) can then be connected to a vehicular power circuit (or equivalent) protected by a 5 A slow blow fuse (user supplied).

The following SMART Antennas use this cable:

- SMART7
- SMART7 with RELAY7
- SMART2



The SMART Antenna interface cable is also compatible with the Ag-Star, SMART6 and SMART6-L.

Figure 22: SMART Antenna Interface Cable

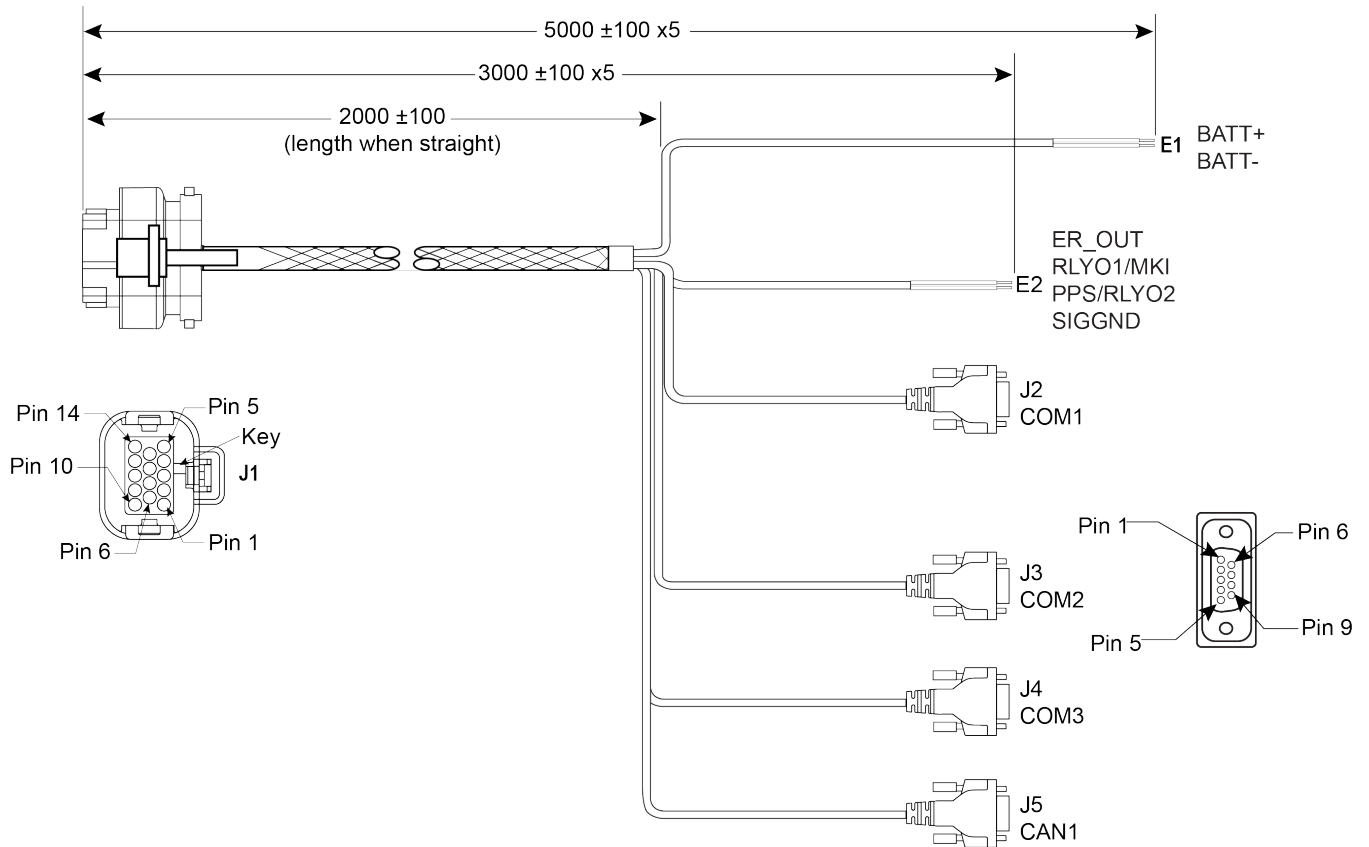

Dimensions are in millimeters.

Table 19: SMART Antenna Interface Cable Connector Pin Out

Signal Name	J1	J2	J3	J4	J5	E1	E2
COM1-TXD	1	2					
COM1-RXD	2	3					
COM2-TXD	3		2				
COM2-RXD	4		3				
COM3-TXD	8			2			
COM3-RXD	13			3			
CAN+	6				7		
CAN-	7				2		
SIGGND	5	5					
SIGGND	5		5				
SIGGND	5			5			
SIGGND	5				3		
SIGGND	5						SIGGND
EMD RADAR OUT (E2)	10						ER_OUT
RELAYO1/MARK INPUT (E2) ¹	11						MKI
PPS/RLYO2 (E2)	12						PPS
PWR RET (GND) (E1)	9					BATT-	
PWR INPUT (E1)	14					BATT+	

Table 20: 14-Pin Interface Connector

CAN	SAE J1939/ ISO 11783/ ISO 11898 Compatible
PPS Output	3.3 V CMOS Logic Compatible
Ground Speed Output	High= Supply Voltage Maximum Low= 1.5 V Maximum Load= 3K Ohm Minimum

A.6.1 SMART Antenna Custom Cable Recommendation

To create a custom cable for a SMART Antenna, a specific connector is required on the end of the cable. See the following table for information about this connector.

¹The Mark Input is not available on the SMART7.

Table 21: I/O Connector

Connector	Description	Commercial Part Number
J1	AMP Seal 14-pin Plug	776273-1

APPENDIX B SMART2 Accessories and Replacement Parts

The following tables list the replacement parts available for your NovAtel SMART2 receiver. For assistance or to order additional components, contact your local NovAtel dealer or NovAtel Customer Support.

Table 22: SMART2 Hardware Options

Tradename	Description	Part Number
SMART2	SMART2	01020287, 01020311
SMART2-B	SMART2 with Bluetooth	01020291, 01020309
SMART2-TB	SMART2 with Bluetooth and Terrain Compensation	01020293, 01020313

Table 23: SMART2 Accessory Products

Part Number	Description
01018317	Surface Mounting Plate for SMART2
01019142	Pole Mounting Plate for SMART2
01019944	SMART Antenna Interface Cable

