



**OEM7 SPAN  
Installation and Operation  
User Manual**

---

# OEM7 SPAN Installation and Operation User Manual

**Publication Number:** OM-20000170

**Revision Level:** v16

**Revision Date:** January 2021

**Firmware Version:** 7.08.01 / OM7MR0801RN0000

## Warranty

NovAtel Inc. warrants that its GNSS products are free from defects in materials and workmanship, subject to the conditions set forth on our web site: [novatel.com/products/novatel-warranty-and-return-policies](http://novatel.com/products/novatel-warranty-and-return-policies) and for the following time periods:

## Return instructions

To return products, refer to the instructions found at: [novatel.com/products/novatel-warranty-and-return-policies](http://novatel.com/products/novatel-warranty-and-return-policies).

## Proprietary Notice

Information in this document is subject to change without notice and does not represent a commitment on the part of NovAtel Inc. The software described in this document is furnished under a licence agreement or non-disclosure agreement. The software may be used or copied only in accordance with the terms of the agreement. It is against the law to copy the software on any medium except as specifically allowed in the license or non-disclosure agreement.

No part of this manual may be reproduced or transmitted in any form or by any means, electronic or mechanical, including photocopying and recording, for any purpose without the express written permission of a duly authorized representative of NovAtel Inc.

The information contained within this manual is believed to be true and correct at the time of publication.

ALIGN, GLIDE, Inertial Explorer, NovAtel, OEM6, OEM7, PwrPak7, SPAN, TerraStar and Waypoint are trademarks of NovAtel, Inc., entities within the Hexagon Autonomy & Positioning division, their affiliated entities, and/or their licensors. All other trademarks are properties of their respective owners.

© Copyright 2021 NovAtel Inc. All rights reserved. Unpublished rights reserved under International copyright laws.

---

# Table of Contents

## Figures

## Tables

## Receiver Card Notices

## Customer Support

### Chapter 1 OEM7 SPAN Overview

1.1	Fundamentals of GNSS+INS .....	28
1.2	Models and Features .....	29
1.2.1	INS Options .....	29
1.2.2	IMU Grade .....	30
1.3	Related Documents and Information .....	31

### Chapter 2 SPAN Installation

2.1	OEM7 Receiver Card Installation .....	33
2.1.1	Selecting a GNSS Antenna .....	34
2.1.2	Choosing a Coaxial Cable .....	34
2.1.3	Mounting the GNSS Antenna .....	35
2.1.4	Mount the IMU .....	36
2.1.5	Connect the IMU to the OEM7 Receiver Card .....	38
2.1.6	Connect Power .....	55
2.2	MIC Installation .....	57
2.2.1	Install a MIC in a Stack Up Configuration .....	57
2.2.2	Install a MIC in a Standalone Configuration .....	62
2.3	UIC Installation .....	68
2.3.1	Mount the SPAN System Components .....	69
2.3.2	Connect the IMU to the UIC .....	70
2.3.3	Connect the UIC to a receiver .....	70
2.3.4	Connect Power to the UIC and OEM7 Receiver .....	71
2.3.5	UIC Status LEDs .....	71
2.4	PwrPak7 Installation .....	72
2.4.1	Connect the IMU to the PwrPak7 .....	73
2.5	PwrPak7-E1/PwrPak7-E2 Installation .....	75
2.6	IMU LEDs .....	76

### Chapter 3 SPAN Operation

3.1	Definition of Reference Frames Within SPAN .....	78
3.1.1	The Local-Level Frame (ENU) .....	78
3.1.2	The IMU Body Frame .....	79
3.1.3	The Vehicle Frame .....	79
3.1.4	The User Output Frame .....	80
3.2	SPAN Translations and Rotations .....	80

3.2.1	Translational Offsets .....	80
3.2.2	Rotational Offsets .....	82
3.3	Software Configuration .....	83
3.3.1	GNSS Configuration .....	83
3.3.2	INS Profiles .....	84
3.3.3	SPAN Configuration for Receiver Cards .....	85
3.3.4	SPAN Configuration for PwrPak7 .....	89
3.3.5	Importance of RBV Calibration .....	93
3.4	Real-Time Operation .....	95
3.4.1	System Start-Up and Alignment Techniques .....	96
3.4.2	INS Seed / Fast INS Initialization .....	98
3.4.3	Navigation Mode .....	100
3.4.4	Data Collection .....	100
3.4.5	Lever Arm Calibration Routine .....	102
3.4.6	Body to Vehicle Frame Rotation Calibration Routine .....	103
3.4.7	Multi-Line Body to Vehicle Frame Rotation Calibration Routine .....	104
3.5	Synchronizing External Equipment .....	106
3.5.1	Configuring an Input Strobe .....	106
3.6	Adding Timed Sensor Triggers .....	107
3.6.1	Configuring the Hardware .....	107
3.6.2	Configuring the Software .....	108
3.6.3	Using Timed Event Pulses .....	108
3.6.4	Recording Incoming Sensor Events .....	108
3.7	Distance Measurement Instrument .....	108
3.7.1	DMI Communication .....	109
3.7.2	DMI Connection .....	109
3.7.3	DMI Requirements .....	109
3.7.4	DMI Connected to a PwrPak7 .....	111
3.7.5	DMI Connected to an IMU .....	113
3.7.6	DMI Connected to a UIC .....	115
3.7.7	DMI Connected to an Intermediate Processor .....	117
3.7.8	DMI Command Compatibility .....	119
3.7.9	DMI Troubleshooting .....	120
3.8	Azimuth Sources on a SPAN System .....	120
3.8.1	Course Over Ground .....	121
3.8.2	Inertial Azimuth .....	121
3.8.3	ALIGN Azimuth .....	121
3.9	Data Collection for Post Processing .....	122
3.10	Firmware Updates and Model Upgrades .....	123
3.11	Variable Lever Arm .....	123
3.11.1	Reference Frame Description .....	123
3.11.2	How to Use Variable Lever Arm .....	125
3.12	Relative INS .....	127
3.12.1	Configure Relative INS .....	128

## Chapter 4 SPAN with Dual Antenna

4.1	Installation .....	130
-----	--------------------	-----

4.2	Configuring ALIGN with SPAN .....	132
4.3	Configuring SPAN with ALIGN .....	133
4.3.1	Aided Transfer Alignment – ALIGN Injected Azimuth .....	134
4.3.2	Unaided Alignment .....	134
4.3.3	Automatic Alignment Mode – Automatic Alignment (default) .....	134
4.4	SPAN ALIGN Attitude Updates .....	134

## **APPENDIX A IMU Technical Specifications**

A.1	HG1700 IMU (single-connector enclosure) .....	136
A.1.1	HG1700 IMU Mechanical Drawings .....	137
A.1.2	HG1700 IMU Performance .....	139
A.1.3	HG1700 Electrical and Environmental .....	140
A.1.4	Interface Cable for the HG1700 IMU .....	140
A.2	IMU-CPT .....	141
A.2.1	IMU-CPT Mechanical Drawings .....	142
A.2.2	IMU-CPT Sensor Specifications .....	144
A.2.3	IMU-CPT Electrical and Environmental .....	145
A.2.4	IMU-CPT Cable .....	146
A.3	IMU-FSAS .....	148
A.3.1	IMU-FSAS Mechanical Drawings .....	149
A.3.2	IMU-FSAS Performance .....	152
A.3.3	IMU-FSAS Electrical and Environmental .....	152
A.3.4	Interface Cable for IMU-FSAS .....	153
A.3.5	IMU-FSAS Cable with Wheel Sensor .....	153
A.4	IMU-HG1900 .....	156
A.4.1	IMU-HG1900 Mechanical Drawings .....	157
A.4.2	IMU-HG1900 Sensor Specifications .....	159
A.4.3	IMU-HG1900 Electrical and Environmental .....	160
A.4.4	IMU-HG1900 Cables .....	160
A.5	IMU-IGM .....	161
A.5.1	IMU-IGM Mechanical Drawings .....	162
A.5.2	IMU-IGM Ports .....	164
A.5.3	IMU-IGM Sensor Specifications .....	166
A.5.4	IMU-IGM Electrical and Environmental .....	167
A.5.5	IMU-IGM Interface Cable .....	168
A.6	IMU-ISA-100C .....	170
A.6.1	IMU-ISA-100C Mechanical Drawings .....	171
A.6.2	Optional Side Mounting Holes .....	173
A.6.3	IMU-ISA-100C Performance .....	175
A.6.4	IMU-ISA-100C Electrical and Environmental .....	176
A.6.5	IMU Enclosure Interface Cable .....	177
A.6.6	IMU Enclosure Power Cable .....	179
A.6.7	IMU Enclosure Wheel Sensor Cable .....	180
A.7	IMU-KVH1750 .....	182
A.7.1	IMU-KVH1750 Mechanical Drawings .....	183
A.7.2	IMU-KVH1750 Sensor Specifications .....	187
A.7.3	IMU-KVH1750 Electrical and Environmental .....	188

A.7.4	IMU-KVH1750 Cable .....	189
A.8	IMU-ENC-LN200 .....	191
A.8.1	IMU-ENC-LN200 Mechanical Drawings .....	192
A.8.2	IMU-ENC-LN200 Sensor Specifications .....	194
A.8.3	IMU-ENC-LN200 Electrical and Environmental .....	195
A.8.4	IMU-ENC-LN200 Cables .....	195
A.9	IMU- $\mu$ IMU-IC .....	196
A.9.1	IMU- $\mu$ IMU-IC Mechanical Drawings .....	197
A.9.2	IMU- $\mu$ IMU-IC Sensor Specifications .....	199
A.9.3	IMU- $\mu$ IMU-IC Electrical and Environmental .....	200
A.9.4	IMU- $\mu$ IMU-IC Cables .....	200
A.10	LN-200 IMU (single-connector enclosure) .....	201
A.10.1	LN-200 IMU Mechanical Drawings .....	202
A.10.2	LN-200 IMU Performance .....	204
A.10.3	LN-200 Electrical and Environmental .....	204
A.10.4	Interface Cable for the LN-200 IMU .....	205
A.11	OEM-IMU-ADIS-16488 .....	206
A.11.1	OEM-IMU-ADIS-16488 Mechanical Drawings .....	207
A.11.2	OEM-IMU-ADIS-16488 Sensor Specifications .....	210
A.11.3	OEM-IMU-ADIS-16488 Electrical and Environmental .....	210
A.11.4	OEM-IMU-ADIS-16488 SPI Connection .....	211
A.11.5	ADIS-16488 IMU-to-MIC Cable Assembly .....	213
A.12	OEM-IMU-EG320N .....	214
A.12.1	OEM-IMU-EG320N Mechanical Drawings .....	215
A.12.2	OEM-IMU-EG320N Sensor Specifications .....	216
A.12.3	OEM-IMU-EG320N Electrical and Environmental .....	216
A.12.4	OEM-IMU-EG320N Interface Connector .....	217
A.13	OEM-IMU-EG370N .....	219
A.13.1	OEM-IMU-EG370N Mechanical Drawings .....	220
A.13.2	OEM-IMU-EG370N Sensor Specifications .....	221
A.13.3	OEM-IMU-EG370N Electrical and Environmental .....	221
A.13.4	OEM-IMU-EG370N Interface Connector .....	222
A.14	OEM-IMU-HG4930 .....	224
A.14.1	OEM-IMU-HG4930 Mechanical Drawings .....	225
A.14.2	OEM-IMU-HG4930 Sensor Specifications .....	226
A.14.3	OEM-IMU-HG4930 Electrical and Environmental .....	226
A.14.4	OEM-IMU-HG4930 Interface Connector .....	227
A.15	OEM-IMU-ISA-100C .....	228
A.15.1	OEM-IMU-ISA-100C Mechanical Drawings .....	229
A.15.2	OEM-IMU-ISA-100C Sensor Specifications .....	231
A.15.3	OEM-IMU-ISA-100C Electrical and Environmental .....	231
A.15.4	OEM-IMU-ISA-100C IMU to UIC Cable Assembly .....	232
A.16	OEM-IMU-STIM300 .....	235
A.16.1	OEM-IMU-STIM300 Mechanical Drawings .....	236
A.16.2	OEM-IMU-STIM300 Sensor Specifications .....	237
A.16.3	OEM-IMU-STIM300 Electrical and Environmental .....	237
A.16.4	OEM-IMU-STIM300 Direct Connection .....	238

A.16.5	STIM300 IMU-to-MIC Cable Assembly .....	241
A.17	OEM-IMU- $\mu$ IMU .....	243
A.17.1	OEM-IMU- $\mu$ IMU Mechanical Drawings .....	244
A.17.2	OEM-IMU- $\mu$ IMU Sensor Specifications .....	246
A.17.3	OEM-IMU- $\mu$ IMU Electrical and Environmental .....	246
A.17.4	$\mu$ IMU to UIC Cable Assembly .....	247
A.18	Universal IMU Enclosure (HG1700, LN200) .....	249
A.18.1	Universal IMU Enclosure Mechanical Drawings .....	250
A.18.2	IMU Performance .....	254
A.18.3	Electrical and Environmental .....	256
A.18.4	Universal IMU Enclosure Interface Cable .....	257
A.19	MIC - MEMS Interface Card .....	259
A.19.1	MIC Mechanical Drawings .....	260
A.19.2	MIC Electrical and Environmental .....	262
A.19.3	MIC Connectors .....	263
A.19.4	HG1930 IMU-to-MIC Cable Assembly .....	268
A.19.5	HG1700 and HG1900 IMU-to-MIC Cable Assembly .....	270
A.20	UIC - Universal IMU Controller .....	272
A.20.1	UIC Mechanical Drawings .....	273
A.20.2	UIC Electrical and Environmental .....	275
A.20.3	UIC Connectors .....	276
A.20.4	HG1900 IMU to UIC Cable Assembly .....	280
A.20.5	LN200 IMU to UIC Cable Assembly .....	281

## **APPENDIX B HG1700 IMU in Universal Enclosure**

B.1	Disassemble the Universal Enclosure .....	283
B.2	Install the HG1700 Sensor Unit .....	285

## **APPENDIX C LN-200 IMU in Universal Enclosure**

C.1	Disassemble the Universal Enclosure .....	292
C.2	Install the LN-200 Sensor Unit .....	294

## **APPENDIX D HG1700 IMU in SPAN HG Enclosure**

D.1	Disassemble the SPAN IMU Enclosure .....	299
D.2	Install the HG1700 Sensor Unit .....	301
D.3	Make the Electrical Connections .....	302
D.4	Re-Assemble the SPAN IMU Enclosure .....	304

## **APPENDIX E LN-200 IMU in SPAN IMU Enclosure**

E.1	Disassemble the SPAN IMU Enclosure .....	305
E.2	Install the LN-200 Sensor Unit .....	307
E.3	Make the Electrical Connections .....	308
E.4	Re-Assemble the SPAN IMU Enclosure .....	310

---

**APPENDIX F Frequently Asked Questions**

**APPENDIX G Importance of Antenna Selection**

**APPENDIX H Accessories and Replacement Parts**



# Figures

Figure 1: Typical Installation of a SPAN System with an OEM7 Receiver Card .....	33
Figure 2: IMU Enclosure Mounting Plate .....	37
Figure 3: OEM-IMU-ADIS-16488 Pin Locations .....	42
Figure 4: EG320N/EG370N Pin Locations .....	44
Figure 5: OEM-IMU-STIM300 Pin Out .....	47
Figure 6: Basic Set Up – MIC in Stack Up Configuration .....	58
Figure 7: Mount the MIC on the OEM719 .....	60
Figure 8: Connect the HG1900 IMU to the MIC (OEM Cable Kit: 01018871) .....	61
Figure 9: Connect the HG1930 IMU to the MIC (OEM Cable Kit: 01018869) .....	61
Figure 10: Connect the ADIS-16488 IMU to the MIC (OEM Cable Kit: 01019007) .....	61
Figure 11: Connect the STIM300 IMU to the MIC (OEM Cable Kit: 01019174) .....	62
Figure 12: Basic MIC Set Up .....	63
Figure 13: Connect the HG1900 IMU to the MIC (OEM Cable Kit: 01018871) .....	65
Figure 14: Connect the HG1930 IMU to the MIC (OEM Cable Kit: 01018869) .....	65
Figure 15: Connect the ADIS-16488 IMU to the MIC (OEM Cable Kit: 01019007) .....	66
Figure 16: Connect the STIM300 IMU to the MIC (OEM Cable Kit: 01019174) .....	66
Figure 17: Basic UIC Installation .....	68
Figure 18: UIC Status LEDs .....	71
Figure 19: Typical Installation of a SPAN System with a PwrPak7 .....	72
Figure 20: Typical Installation of a SPAN System with a PwrPak7-E1 .....	75
Figure 21: Local-Level Frame (ENU) .....	79
Figure 22: IMU Body Frame Marking .....	79
Figure 23: Vehicle Frame .....	80
Figure 24: IMU to Antenna Translation Offset .....	81
Figure 25: Rear View of PwrPak7-E1 – Mounting Plate is not Flat .....	94
Figure 26: Side View of PwrPak7-E1 – Vehicle is not Level .....	94
Figure 27: Top View of PwrPak7-E1 – PwrPak7-E1 Misalignment .....	94
Figure 28: Multi-Line IMU Body to Vehicle Calibration .....	105
Figure 29: Kistler WPT .....	110
Figure 30: DMI to PwrPak7 Setup .....	112
Figure 31: DMI to IMU Setup .....	114
Figure 32: DMI to UIC Setup .....	116
Figure 33: DMI through Intermediate Processor Setup .....	117
Figure 34: Sample Configuration .....	124
Figure 35: Operating Gimbal .....	125

Figure 36: Relative INS Example .....	128
Figure 37: SPAN - Two Receiver Dual Antenna Installation .....	131
Figure 38: SPAN - Single Receiver Dual Antenna Installation .....	132
Figure 39: HG1700 Top/Bottom Dimensions .....	137
Figure 40: HG1700 Enclosure Side Dimensions .....	138
Figure 41: IMU-CPT Side and Perspective View .....	142
Figure 42: IMU-CPT Top, Front and Bottom View .....	143
Figure 43: IMU-CPT Development Terminated Cable .....	146
Figure 44: IMU-FSAS Top Dimensions .....	149
Figure 45: IMU-FSAS Bottom Dimensions .....	149
Figure 46: IMU-FSAS Side Dimensions .....	150
Figure 47: IMU-FSAS Center of Navigation .....	151
Figure 48: IMU-FSAS Interface Cable with Wheel Sensor .....	153
Figure 49: IMU-HG1900 Dimensions .....	157
Figure 50: IMU-HG1900 Center of Navigation .....	158
Figure 51: IMU-IGM-A1 Dimensions .....	162
Figure 52: IMU-IGM-S1 Dimensions .....	163
Figure 53: IMU-IGM Interface Cable .....	168
Figure 54: IMU-ISA-100C Dimensions .....	171
Figure 55: IMU-ISA-100C Center of Navigation .....	172
Figure 56: Optional Side Mounting Holes .....	174
Figure 57: IMU Enclosure Interface Cable .....	177
Figure 58: IMU Enclosure Power Cable .....	179
Figure 59: IMU Enclosure Wheel Sensor Cable .....	180
Figure 60: IMU-KVH1750 Bottom view .....	183
Figure 61: IMU-KVH1750 Top View .....	184
Figure 62: IMU-KVH1750 Side View .....	185
Figure 63: IMU-KVH1750 Gyro Axes .....	186
Figure 64: IMU-KVH1750 Cable .....	189
Figure 65: IMU-ENC-LN200 Dimensions .....	192
Figure 66: IMU-ENC-LN200 Center of Navigation .....	193
Figure 67: IMU- $\mu$ IMU-IC Dimensions .....	197
Figure 68: IMU- $\mu$ IMU-IC Center of Navigation .....	198
Figure 69: LN-200 IMU Enclosure Top/Bottom Dimensions and Center of Navigation .....	202
Figure 70: LN-200 Enclosure Side Dimensions .....	203
Figure 71: ADIS-16488 Dimensions .....	207

Figure 72: ADIS-16488 Center of Navigation .....	208
Figure 73: OEM ADIS-16488 Dimensions .....	209
Figure 74: ADIS-16488 IMU-to-MIC Cable Assembly .....	213
Figure 75: EG320N Dimensions .....	215
Figure 76: OEM-IMU-EG320N Pin Locations .....	217
Figure 77: EG370N Dimensions .....	220
Figure 78: OEM-IMU-EG370N Pin Locations .....	222
Figure 79: OEM-IMU-HG4930 Center of Navigation .....	225
Figure 80: ISA-100C Dimensions .....	229
Figure 81: ISA-100C Coordinate Axis .....	230
Figure 82: OEM-IMU-ISA-100C IMU to UIC Cable Assembly .....	232
Figure 83: STIM300 Dimensions .....	236
Figure 84: STIM300 Center of Navigation .....	236
Figure 85: STIM300 IMU-to-MIC Cable Assembly .....	241
Figure 86: $\mu$ IMU Top Dimensions .....	244
Figure 87: $\mu$ IMU Side Dimensions .....	244
Figure 88: $\mu$ IMU Bottom Dimensions .....	245
Figure 89: $\mu$ IMU Coordinate Axis .....	245
Figure 90: $\mu$ IMU to UIC Cable Assembly .....	247
Figure 91: Universal IMU Enclosure Side Dimensions .....	250
Figure 92: Universal IMU Enclosure Top/Bottom Dimensions .....	251
Figure 93: Universal IMU Center of Navigation .....	252
Figure 94: Universal IMU Frame Axis .....	253
Figure 95: Universal IMU Enclosure Interface Cable .....	257
Figure 96: MIC Top/Bottom Dimensions .....	260
Figure 97: MIC Keep-Out Zone .....	261
Figure 98: HG1930 IMU-to-MIC Cable Assembly .....	268
Figure 99: HG1700 and HG1900 IMU-to-MIC Cable Assembly .....	270
Figure 100: UIC Dimensions and Keep Out Zones .....	273
Figure 101: UIC Connectors, LEDs and Heat Sink Details .....	274
Figure 102: OEM-IMU-HG1900 IMU to UIC Cable Assembly .....	280
Figure 103: OEM-IMU-LN200 IMU to UIC Cable Assembly .....	281
Figure 104: Required Parts .....	283
Figure 105: Remove Base .....	284
Figure 106: Disconnect Wiring Harness from Enclosure Body .....	284
Figure 107: Remove IMU Mounting Plate and Bracket .....	285

Figure 108: Remove IMU Mounting Screws .....	286
Figure 109: Connect IMU to IMU Mounting Plate .....	286
Figure 110: Installing IMU to Mounting Plate .....	287
Figure 111: Assemble Into Enclosure Body .....	288
Figure 112: Fasten Internal Cable Harness .....	289
Figure 113: Install O-rings .....	289
Figure 114: Install Enclosure Body on the Base .....	290
Figure 115: Screw Enclosure Base to Body .....	290
Figure 116: Final Assembly .....	291
Figure 117: Required Parts .....	292
Figure 118: Remove Base .....	293
Figure 119: Disconnect Wiring Harness from SDLC Card .....	293
Figure 120: IMU Bracket .....	294
Figure 121: Remove IMU Bracket/SDLC .....	294
Figure 122: Install LN-200 IMU to Base .....	295
Figure 123: Install Bracket to Base .....	295
Figure 124: Making Connections .....	296
Figure 125: Connect Internal Cable Harness .....	296
Figure 126: Installing the Enclosure Body to the Base .....	297
Figure 127: Screw Enclosure Base to Body .....	297
Figure 128: Final Assembly .....	298
Figure 129: Required Parts .....	299
Figure 130: Bolts and Hex Key .....	300
Figure 131: Lift Top Cover, Tube Body and 3 Ring Spacer Screws .....	301
Figure 132: SPAN IMU Re-Assembly .....	302
Figure 133: Attach Flex Cable .....	303
Figure 134: Incorrect (Bowed) Flex Cable Installation .....	304
Figure 135: Correct (Flat) Flex Cable Installation .....	304
Figure 136: HG1700 SPAN IMU .....	304
Figure 137: Required Parts .....	305
Figure 138: Bolts and Hex Key .....	306
Figure 139: Lift Top Cover and Tube Body .....	307
Figure 140: SPAN IMU Re-Assembly .....	308
Figure 141: Attach Wiring Harness .....	309
Figure 142: Attach Samtec Connector .....	310
Figure 143: LN-200 SPAN IMU .....	311

Figure 144: Plot of Good and Poor Antenna Phase Center Variation over Elevation Angle 0-90° .....315

# Tables

Table 1: INS Options .....	29
Table 2: SPAN-Compatible IMUs .....	30
Table 3: IMU Connection Method .....	38
Table 4: Receiver to ADIS-16488 Pin Connections .....	42
Table 5: Receiver to EG320N/EG370N Pin Connections .....	45
Table 6: OEM7 Receiver Card to STIM300 Pin Connections .....	47
Table 7: OEM729 COM1 or PwrPak7 to STIM300 Pin Connections .....	48
Table 8: OEM-IMU-HG4930 Mating Connector .....	50
Table 9: OEM7 Receiver Card to HG4930 Pin Connections .....	50
Table 10: COM1 on the OEM729 to HG4930 Pin Connections .....	52
Table 11: PwrPak7 to HG4930 Pin Connections .....	53
Table 12: IMU Power Supply .....	55
Table 13: COM Port Recommendations .....	66
Table 14: COM Port Recommendations .....	70
Table 15: UIC Status LEDs .....	71
Table 16: Additional IMU to PwrPak7 Connections .....	74
Table 17: IMU-IGM LEDs .....	76
Table 18: IMU Enclosure LEDs .....	76
Table 19: OEM7 INS Profiles .....	84
Table 20: Enable INS Commands .....	86
Table 21: Enable INS Commands .....	90
Table 22: Inertial Solution Status .....	95
Table 23: NVM Seed Indication .....	100
Table 24: Solution Parameters .....	100
Table 25: Valid Event Inputs and Outputs for Timed Sensor Triggers .....	107
Table 26: Wheel Sensor Maximum Pulse Rates .....	110
Table 27: Kistler to NovAtel Wheel Sensor Cable Connections .....	111
Table 28: DMI Command and Log Compatibility .....	120
Table 29: Logs with Azimuth Data .....	121
Table 30: Logs used with Variable Lever Arm .....	126
Table 31: Commands used with Variable Lever Arm .....	126
Table 32: HG1700 IMU Physical Specifications .....	136
Table 33: HG1700-AG58 IMU Performance .....	139
Table 34: HG1700-AG62 IMU Performance .....	139
Table 35: HG17000 Electrical Specifications .....	140

Table 36: HG17000 Environmental Specifications .....	140
Table 37: IMU-CPT Physical Specifications .....	141
Table 38: IMU-CPT Performance .....	144
Table 39: IMU-CPT Electrical Specifications .....	145
Table 40: IMU-CPT Environmental Specifications .....	145
Table 41: IMU-CPT Connector Pinout Descriptions .....	146
Table 42: Connectors .....	147
Table 43: Maximum Cable Length .....	147
Table 44: IMU-FSAS Physical Specifications .....	148
Table 45: IMU-FSAS Performance .....	152
Table 46: IMU-FSAS Electrical Specifications .....	152
Table 47: IMU-FSAS Environmental Specifications .....	152
Table 48: IMU-FSAS Cable with Wheel Sensor Pinout .....	154
Table 49: Connectors .....	155
Table 50: Maximum Cable Length .....	155
Table 51: IMU-HG1900 Physical Specifications .....	156
Table 52: IMU-HG1900 IMU Performance .....	159
Table 53: IMU-HG1900 Electrical Specifications .....	160
Table 54: IMU-HG1900 Environmental Specifications .....	160
Table 55: IMU-IGM-A1 Physical Specifications .....	161
Table 56: IMU-IGM-S1 Physical Specifications .....	161
Table 57: IMU-IGM Main Port Pinout .....	164
Table 58: IMU-IGM AUX Port Pinout .....	164
Table 59: IMU-IGM-A1 IMU Performance .....	166
Table 60: IMU-IGM-S1 IMU Performance .....	166
Table 61: IMU-IGM-A1 Electrical Specifications .....	167
Table 62: IMU-IGM-A1 Environmental Specifications .....	167
Table 63: IMU-IGM-S1 Electrical Specifications .....	167
Table 64: IMU-IGM-S1 Environmental Specifications .....	167
Table 65: IMU-IGM Interface Cable Pinout Descriptions .....	168
Table 66: Connectors .....	169
Table 67: Maximum Cable Length .....	169
Table 68: IMU-ISA-100C Physical Specifications .....	170
Table 69: IMU-ISA-100C IMU Performance .....	175
Table 70: IMU-ISA-100C Electrical Specifications .....	176
Table 71: IMU-ISA-100C Environmental Specifications .....	176

---

Table 72: IMU Enclosure Interface Cable Pinouts .....	177
Table 73: Connectors .....	178
Table 74: Maximum Cable Length .....	178
Table 75: IMU Enclosure Power Cable Pinouts .....	179
Table 76: IMU Enclosure Wheel Sensor Cable Pinouts .....	180
Table 77: Connectors .....	181
Table 78: Maximum Cable Length .....	181
Table 79: IMU-KVH1750 Physical Specifications .....	182
Table 80: IMU-KVH1750 Performance .....	187
Table 81: IMU-KVH1750 Electrical Specifications .....	188
Table 82: IMU-KVH1750 Environmental Specifications .....	188
Table 83: IMU-KVH1750 Connector Pinout Descriptions .....	189
Table 84: Connectors .....	190
Table 85: Maximum Cable Length .....	190
Table 86: IMU-ENC-LN200 Physical Specifications .....	191
Table 87: IMU-ENC-LN200 IMU Performance .....	194
Table 88: IMU-ENC-LN200C IMU Performance .....	194
Table 89: IMU-ENC-LN200 Electrical Specifications .....	195
Table 90: IMU-ENC-LN200 Environmental Specifications .....	195
Table 91: IMU- $\mu$ IMU-IC Physical Specifications .....	196
Table 92: IMU- $\mu$ IMU-IC IMU Performance .....	199
Table 93: IMU- $\mu$ IMU-IC Electrical Specifications .....	200
Table 94: IMU- $\mu$ IMU-IC Environmental Specifications .....	200
Table 95: LN-200 IMU Physical Specifications .....	201
Table 96: LN-200 IMU Performance .....	204
Table 97: LN-200 Electrical Specifications .....	204
Table 98: LN-200 Environmental Specifications .....	204
Table 99: OEM-IMU-ADIS-16488 Physical Specifications .....	206
Table 100: OEM-IMU-ADIS-16488 Performance .....	210
Table 101: OEM-IMU-ADIS-16488 Electrical Specifications .....	210
Table 102: OEM-IMU-ADIS-16488 Environmental Specifications .....	210
Table 103: Receiver to ADIS-16488 Pin Connections .....	211
Table 104: ADIS-16488 IMU-to-MIC Cable Pinout .....	213
Table 105: OEM-IMU-EG320N Physical Specifications .....	214
Table 106: OEM-IMU-EG320N Performance .....	216
Table 107: OEM-IMU-EG320N Electrical Specifications .....	216



Table 108: OEM-IMU-EG320N Environmental Specifications .....	216
Table 109: OEM-IMU-EG320N Connector .....	217
Table 110: OEM-IMU-EG370N Physical Specifications .....	219
Table 111: OEM-IMU-EG370N Performance .....	221
Table 112: OEM-IMU-EG370N Electrical Specifications .....	221
Table 113: OEM-IMU-EG370N Environmental Specifications .....	221
Table 114: OEM-IMU-EG370N Connector .....	222
Table 115: OEM-IMU-HG4930 Physical Specifications .....	224
Table 116: OEM-IMU-HG4930 Performance .....	226
Table 117: OEM-IMU-HG4930 Electrical Specifications .....	226
Table 118: OEM-IMU-HG4930 Environmental Specifications .....	226
Table 119: OEM-IMU-HG4930 Connector .....	227
Table 120: OEM-IMU-ISA-100C Physical Specifications .....	228
Table 121: OEM-IMU-ISA-100C IMU Performance .....	231
Table 122: OEM-IMU-ISA-100C Electrical Specifications .....	231
Table 123: OEM-IMU-ISA-100C Environmental Specifications .....	231
Table 124: OEM-IMU-ISA-100C IMU to UIC Cable Pinout .....	232
Table 125: OEM-IMU-STIM300 Physical Specifications .....	235
Table 126: OEM-IMU-STIM300 Performance .....	237
Table 127: OEM-IMU-STIM300 Electrical Specifications .....	237
Table 128: OEM-IMU-STIM300 Environmental Specifications .....	237
Table 129: OEM7 Receiver Card to STIM300 Pin Connections .....	238
Table 130: OEM729 COM1 or PwrPak7 to STIM300 Pin Connections .....	239
Table 131: STIM300 IMU-to-MIC Cable Pinout .....	241
Table 132: OEM-IMU- $\mu$ IMU Physical Specifications .....	243
Table 133: OEM-IMU- $\mu$ IMU IMU Performance .....	246
Table 134: OEM-IMU- $\mu$ IMU Electrical Specifications .....	246
Table 135: OEM-IMU- $\mu$ IMU Environmental Specifications .....	246
Table 136: $\mu$ IMU to UIC Cable Pinout .....	247
Table 137: Universal IMU Enclosure Physical Specifications .....	249
Table 138: HG1700-AG58 IMU Performance .....	254
Table 139: HG1700-AG62 IMU Performance .....	254
Table 140: LN200 IMU Performance .....	255
Table 141: Universal IMU Enclosure Electrical Specifications .....	256
Table 142: Universal IMU Enclosure Environmental Specifications .....	256
Table 143: Universal IMU Enclosure Interface Cable Pinouts .....	257

Table 144: Connectors .....	258
Table 145: Maximum Cable Length .....	258
Table 146: MEMS Interface Card Physical Specifications .....	259
Table 147: MIC Electrical Specifications .....	262
Table 148: MIC Electrical and Environmental Specifications .....	262
Table 149: MIC Connectors .....	263
Table 150: Pinouts for Power Connector (P101) .....	263
Table 151: Pinouts for User Interface Connector (P301) .....	263
Table 152: Pinouts for IMU Connector (P601) .....	266
Table 153: Pinouts for IMU Connector (P701) .....	267
Table 154: MIC LED Indicator Drivers .....	267
Table 155: HG1930 IMU-to-MIC Cable Assembly .....	268
Table 156: HG1700 and HG1900 IMU-to-MIC Cable Assembly .....	270
Table 157: UIC Physical Specifications .....	272
Table 158: UIC Electrical Specifications .....	275
Table 159: UIC Environmental Specifications .....	275
Table 160: UIC Connectors .....	276
Table 161: Pinouts for Power Connector (J101) .....	276
Table 162: Pinouts for UIC to Receiver Communications Connector (J102) .....	276
Table 163: Pinouts for UIC to IMU Communications Connector (J1401) .....	277
Table 164: OEM-IMU-HG1900 IMU to UIC Cable Pinout .....	280
Table 165: OEM-IMU-LN200 IMU to UIC Cable Pinout .....	281
Table 166: OEM7 Receivers .....	317
Table 167: SPAN Compatible IMUs .....	318
Table 168: GNSS Antennas .....	319
Table 169: IMU Interface Cables .....	319
Table 170: GNSS Antenna Cables .....	320

# Receiver Card Notices

The following notices apply to the OEM7 family products.



Changes or modifications to this equipment, not expressly approved by NovAtel Inc., could void the user's authority to operate this equipment.

## FCC

The devices covered by this manual comply with part 15 of the FCC Rules. Operation is subject to the following two conditions: (1) this device may not cause harmful interference, and (2) this device must accept any interference received, including interference that may cause undesired operation.

The equipment listed has been tested and found to comply with the limits for a Class B digital device, pursuant to part 15 of the FCC Rules. The Class B limits are designed to provide reasonable protection against harmful interference in a residential installation. The equipment listed generates, uses, and can radiate radio frequency energy and, if not installed and used in accordance with the instructions, may cause harmful interference to radio communications. However, there is no guarantee that interference will not occur in a particular installation. If this equipment does cause harmful interference to radio or television reception, which can be determined by turning the equipment off and on, the user is encouraged to try to correct the interference by one or more of the following measures:

- Reorient or relocate the receiving antenna
- Increase the separation between the equipment and the receiver
- Connect the equipment to an outlet on a circuit different from that to which the receiver is connected
- Consult the dealer or an experienced radio/TV technician for help

## Innovation, Science and Economic Development (ISED) Canada

OEM7 Class B digital device complies with Canadian ICES-003.

OEM7 appareils numérique de la classe B sont conforme à la norme NMB-003 du Canada.

This device complies with ISED license-exempt RSS-GEN and RSS-247. Operation is subject to the following two conditions: (1) this device may not cause interference and (2) this device must accept any interference, including interference that may cause undesired operation of the device.

Cet appareil est conforme à la norme ISED RSS-GEN et RSS-247. Son fonctionnement est soumis aux deux conditions suivantes: (1) cet appareil ne doit pas provoquer d'interférences et (2) cet appareil doit accepter toute interférence, y compris les interférences pouvant entraîner un fonctionnement indésirable de l'appareil.

## European Union (EU)


Hereby, NovAtel Inc. declares that the radio equipment type OEM7 GNSS receiver is in compliance with Directive 2014/53/EU

The full text of the EU Declaration of Conformity may be obtained from the NovAtel website at: [nova-tel.com/products/novatel-compliance/eu-declaration-of-conformity](http://nova-tel.com/products/novatel-compliance/eu-declaration-of-conformity).

## WEEE

If you purchased your OEM7 family product in Europe, please return it to your dealer or supplier at the end of life. The objectives of the European Community's environment policy are, in particular, to preserve, protect and

improve the quality of the environment, protect human health and utilise natural resources prudently and rationally. Sustainable development advocates the reduction of wasteful consumption of natural resources and the prevention of pollution. Waste Electrical and Electronic Equipment (WEEE) is a regulated area. Where the generation of waste cannot be avoided, it should be reused or recovered for its material or energy. WEEE

products may be recognized by their wheeled bin label ()

See [novatel.com/products/novatel-compliance/novatel-environmental-compliance](https://www.novatel.com/products/novatel-compliance/novatel-environmental-compliance) for more information.

## **RoHS**

The OEM7 GNSS receivers are in conformity with Directive 2011/65/EU of the European Parliament and of the Council of 8 June 2011 on the restriction of the use of certain hazardous substances in electrical and electronic equipment.

## Lightning Protection Installation and Grounding Procedure

### ***What is the hazard?***

A lightning strike into the ground causes an increase in the earth's potential which results in a high voltage potential between the center conductor and shield of the coaxial cable. This high voltage develops because the voltage surge induced onto the center conductor lags in time behind the voltage surge induced onto the shield.

### ***Hazard Impact***

A lightning strike causes the ground potential in the area to rise to dangerous levels resulting in harm to personnel or destruction of electronic equipment in an unprotected environment. It also conducts a portion of the strike energy down the inner conductor of the coaxial cable to the connected equipment.



Only qualified personnel, such as electricians mandated by the governing body in the country of installation, may install lightning protection devices.

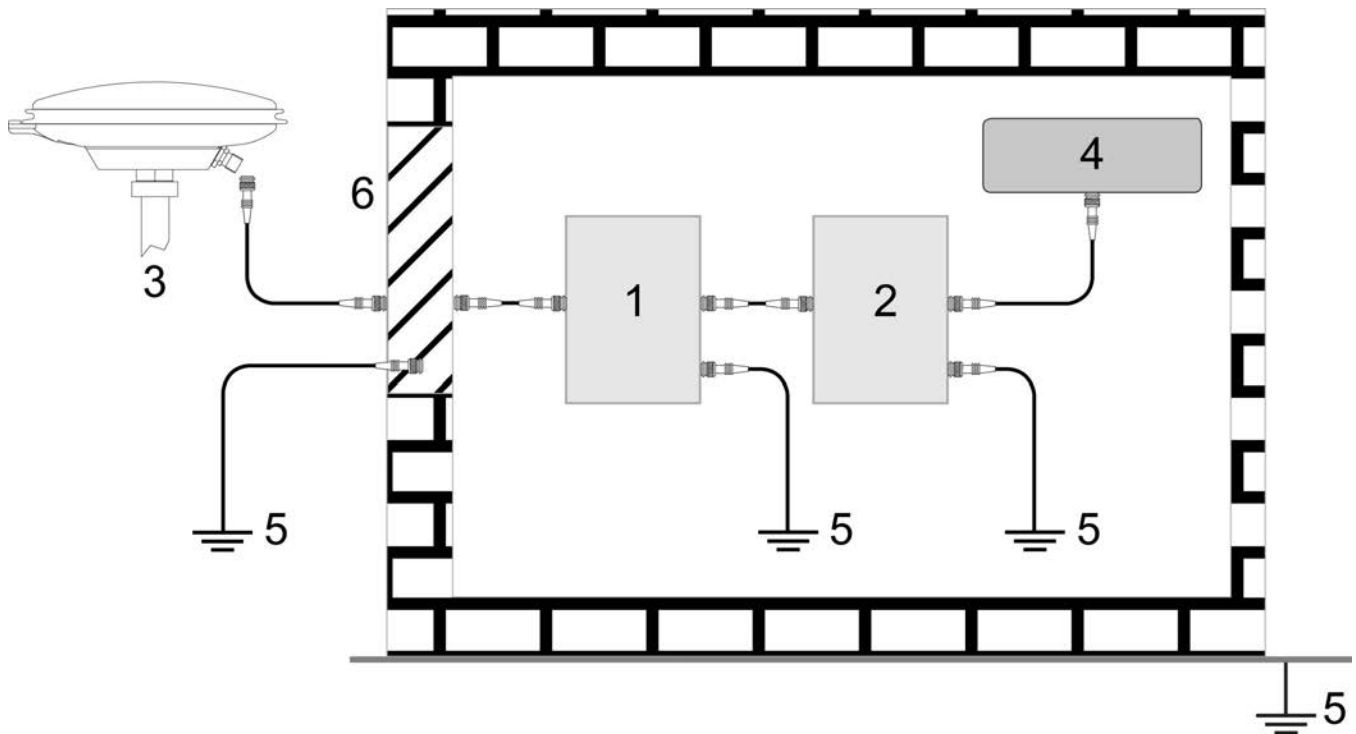
### ***Actions to Mitigate Lightning Hazards***

1. Do not install antennas or antenna coaxial cables outside the building during a lightning storm.
2. It is not possible to avoid over voltages caused by lightning, but a lightning protection device may be used to shunt a large portion of the transient energy to the building ground, reducing the over voltage condition as quickly as possible.
3. Primary lightning protection must be provided by the operator/customer according to local building codes as part of the extra building installation.
4. To ensure safe operation, a secondary lightning protection device must be used for in-building equipment installations with external antennas. The following device has been approved by NovAtel Inc.:

Polyphaser - Surge Arrestor DGXZ+36NFNF-A

If this device is not chosen as the primary lightning protection device, the device chosen must:

- Be UL listed (or equivalent) in the country of installation for lightning surge protection
  - The primary device must be capable of limiting an incoming surge to 10 kV
5. The shield of the coaxial cable entering the building should be connected at a grounding plate at the building's entrance. The lightning protection devices should have their chassis grounded to the same ground near to the building's entrance.
  6. The primary and secondary lightning protections should be as close to the building's entrance as possible. Where feasible, mount onto the grounding plate itself (refer to the figure below).



Ref #	Description
1	Primary lightning protection device
2	Secondary lightning protection device
3	External antenna
4	GNSS Receiver
5	To ground
6	Grounding plate or grounding point at the building's entrance



Acceptable choices for earth grounds, for central buildings, are:

- Grounded interior metal cold water pipe within five feet (1.5 m) of the point where it enters the building
- Grounded metallic service raceway
- Grounded electrical service equipment enclosure
- Eight-foot grounding rod driven into the ground (only if bonded to the central building ground by #6, or heavier, bonding wire)

These installation instructions are the minimum requirements for receiver and antenna installations. Where applicable, follow the electrical codes for the country of installation. Examples of country codes include:

- **USA** National Electrical Code (NFPA 70)
- **Canada** Canadian Electrical Code (CSA C22.1)
- **UK** British Standard (BS7671)

## **Ethernet Port**



The Ethernet port is a safety extra-low voltage (SELV) circuit only and is suitable for connection within a building only. Do not connect them to Telecommunications Network Voltage (TNV) circuits.

## **Conventions**

The following conventions are used in this manual:



Information that supplements or clarifies text.



A caution that actions, operation or configuration may lead to incorrect or improper use of the hardware.



A warning that actions, operation or configuration may result in regulatory noncompliance, safety issues or equipment damage.

# Customer Support

## NovAtel Knowledge Base

If you have a technical issue, visit the NovAtel Support page at [novatel.com/support](http://novatel.com/support). Through the *Support* page, you can contact Customer Support, find papers and tutorials or download the latest firmware. To access the latest user documentation, visit [docs.novatel.com/OEM7](http://docs.novatel.com/OEM7).

## Before Contacting Customer Support

Before contacting NovAtel Customer Support about a software problem, perform the following steps:



If logging data over an RS-232 serial cable, ensure that the configured baud rate can support the data bandwidth (see **SERIALCONFIG** command). NovAtel recommends a minimum suggested baud rate of 230400 bps.

1. Log the data suggested in the appropriate *Troubleshooting Logs* section to a file on your computer for 15 minutes.
  - *General Troubleshooting Logs* on the next page
  - *Tracking and Interference Troubleshooting Logs* on the next page
  - *SPAN Troubleshooting Logs* on page 26
  - *RTK Troubleshooting Logs* on page 26
  - *PPP Troubleshooting Logs* on page 27
  - *ALIGN Troubleshooting Logs* on page 27
2. Send the data file to NovAtel Customer Support: [support.novatel@hexagon.com](mailto:support.novatel@hexagon.com)
3. You can also issue a **FRESET** command to the receiver to clear any unknown settings.



The **FRESET** command will erase all user settings. You should know your configuration (by requesting the RXCONFIGA log) and be able to reconfigure the receiver before you send the **FRESET** command.

If you are having a hardware problem, send a list of the troubleshooting steps taken and the results.

## Contact Information

Log a support request with NovAtel Customer Support using one of the following methods:

### Log a Case and Search Knowledge:

Website: [novatel.com/support](http://novatel.com/support)

### Log a Case, Search Knowledge and View Your Case History: (login access required)

Web Portal: <https://novatelsupport.force.com/community/login>

### E-mail:

[support.novatel@hexagon.com](mailto:support.novatel@hexagon.com)



**Telephone:**

U.S. and Canada: 1-800-NOVATEL (1-800-668-2835)

International: +1-403-295-4900

## General Troubleshooting Logs

```
LOG RXSTATUSB ONCHANGED
LOG RAWEPHEMB ONNEW
LOG GLORAWEPHEMB ONNEW
LOG BESTPOSB ONTIME 1
LOG RANGE B ONTIME 1
LOG RXCONFIGA ONCE
LOG VERSIONA ONCE
LOG LOGLISTA ONCE
LOG PORTSTATSA ONTIME 10
LOG PROFILEINFOA ONCE
LOG HWMONITORA ONTIME 10
```

## Tracking and Interference Troubleshooting Logs

```
LOG VERSIONA ONCE
LOG RXCONFIGA ONCE
LOG CHANCONFIGLISTB ONCE
LOG PASSTHROUGH A ONNEW
LOG RXSTATUSB ONCHANGED
LOG CLOCKSTEERINGB ONCHANGED
LOG RAWEPHEMB ONNEW
LOG GLORAWEPHEMB ONNEW
LOG GALINAVRAWEPHEMERISB ONNEW
LOG BDSEPHEMERISB ONNEW
LOG QZSSEPHEMERISB ONNEW
LOG NAVICEPHEMERISB ONNEW
LOG RAWALMB ONNEW
LOG GLORAWALMB ONNEW
LOG GALALMANACB ONNEW
LOG BDSALMANACB ONNEW
LOG QZSSALMANACB ONNEW
LOG NAVICALMANACB ONNEW
LOG IONUTCB ONNEW
LOG GLOCLOCKB ONNEW
LOG GALCLOCKB ONNEW
LOG BDESCLOCKB ONNEW
LOG TRACKSTATB ONTIME 1
LOG RANGE B ONTIME 1
LOG BESTPOSB ONTIME 1
LOG SATVIS2B ONTIME 30
LOG ITDETECTSTATUSB ONCHANGED
```

For dual antenna receivers, add these logs:

```
LOG TRACKSTATB_1 ONTIME 1
LOG RANGE B_1 ONTIME 1
```

For interference issues add this log.

```
LOG ITPSDDETECTB ONNEW
```

For interference issues, when you have enough datalink bandwidth to handle large logs, add this log:

```
LOG ITPSDFINALB ONNEW
```

## SPAN Troubleshooting Logs

```
LOG RXSTATUSB ONCHANGED
LOG RAWEPHEMB ONNEW
LOG GLORAWEPHEMB ONNEW
LOG BESTPOSB ONTIME 1
LOG RANGE B ONTIME 1
LOG RXCONFIGA ONCE
LOG VERSIONA ONCE
LOG RAWIMUSXB ONNEW
LOG INSUPDATESTATUSB ONCHANGED
LOG INSPVAXB ONTIME 1
LOG INSCONFIGA ONCHANGED
LOG BESTGNSSPOSB ONTIME 1
```

## RTK Troubleshooting Logs

```
LOG RXSTATUSB ONCHANGED
LOG RAWEPHEMB ONNEW
LOG GLORAWEPHEMB ONNEW
LOG QZSSRAWEPHEMB ONNEW
LOG BDSRAWNAVSUBFRAMEB ONNEW
LOG GALFNAVRAWEPHEMERISB ONNEW
LOG GALINAVRAWEPHEMERISB ONNEW
LOG RANGE B ONTIME 1.0
LOG BESTPOSB ONTIME 1.0
LOG RXCONFIGB ONCE
LOG VERSIONB ONCE
LOG TRACKSTATB ONTIME 1.0
LOG RTKPOSB ONTIME 1.0
LOG MATCHEDPOSB ONNEW
LOG MATCHEDSATS B ONNEW
LOG RTKSATS B ONTIME 1.0
LOG PSRPOSB ONTIME 1.0
LOG RAWALMB ONNEW
LOG IONUTCB ONNEW
LOG GLORAWALMB ONNEW
LOG GLOCLOCKB ONNEW
LOG PASSTHROUGH B ONNEW
LOG CLOCKMODEL B ONTIME 1.0
LOG REFSTATIONB ONNEW
LOG RTKVELB ONTIME 1.0
```

## PPP Troubleshooting Logs

LOG RXSTATUSB ONCHANGED  
LOG RAWEPHEMB ONNEW  
LOG GLORAWEPHEMB ONNEW  
LOG QZSSRAWEPHEMB ONNEW  
LOG BDSRAWNAVSUBFRAMEB ONNEW  
LOG GALFNAVRAWEPHEMERISB ONNEW  
LOG GALINAVRAWEPHEMERISB ONNEW  
LOG RANGE B ONTIME 1.0  
LOG BESTPOS B ONTIME 1.0  
LOG RXCONFIG B ONCE  
LOG VERSION B ONCE  
LOG TRACKSTAT B ONTIME 1.0  
LOG LBANDTRACKSTAT B ONTIME 1.0  
LOG PPPPOS B ONTIME 1.0  
LOG PPPSATSB ONTIME 1.0  
LOG TERRASTARINFOB ONCHANGED  
LOG TERRASTARSTATUSB ONCHANGED  
LOG PSRPOS B ONTIME 1.0  
LOG ALMANAC B ONNEW  
LOG IONUTCB ONNEW  
LOG GLORAWALMB ONNEW  
LOG GLOCLOCKB ONNEW  
LOG LBANDBEAMTABLEB ONCHANGED

## ALIGN Troubleshooting Logs

LOG RXSTATUSB ONCHANGED  
LOG RAWEPHEMB ONNEW  
LOG GLORAWEPHEMB ONNEW  
LOG BESTPOS B ONTIME 1  
LOG RANGE B ONTIME 1  
LOG RXCONFIG A ONCE  
LOG VERSION A ONCE  
LOG LOGLISTA ONCE  
LOG PORTSTATSA ONTIME 10  
LOG ALIGNBSLNENUB ONNEW  
LOG ALIGNBSLNXYZB ONNEW  
LOG ALIGNDOPB ONNEW  
LOG HEADING2B ONNEW  
LOG MASTERPOS B ONNEW  
LOG ROVERPOS B ONNEW — This log can only be output if you have Y model ALIGN  
LOG HEADINGSATSA ONNEW — This log can only be output on the ALIGN rover  
LOG DUALANTENNAHEADING B ONTIME 1.0

# Chapter 1 OEM7 SPAN Overview

NovAtel's SPAN GNSS+INS technology brings together two very different but complementary positioning and navigation systems namely Global Navigation Satellite System (GNSS) and an Inertial Navigation System (INS). By combining the best aspects of GNSS and INS into one system, SPAN technology is able to offer a solution that is more accurate and reliable than either GNSS or INS could provide alone. The combined GNSS+INS solution has the advantage of the absolute accuracy available from GNSS and the continuity of INS through traditionally difficult GNSS conditions.

The SPAN system consists of the following components:

- NovAtel OEM7 receiver  
These receivers are capable of receiving and tracking different combinations of GPS, GLONASS, Galileo, BeiDou, NavIC and QZSS signals. OEM7 receivers can also allocate channels for the reception of correction service signals from SBAS (standard) and TerraStar PPP (optional). OEM7 adaptability offers multi-system, frequency, and size configurations for any application requirement. Patented Pulsed Aperture Correlator (PAC) technology combined with a powerful microprocessor enable multipath-resistant processing. Excellent acquisition and re-acquisition times allow this receiver to operate in environments where very high dynamics and frequent interruption of signals can be expected. The OEM7 receiver also supports the timing requirements of the IMU and runs the real-time INS filter.
- IMU  
The Inertial Measurement Unit (IMU) consists of three accelerometers and three gyroscopes (gyros) so that accelerations along specific axes and angular rotations can be measured. Several IMU types are supported and are listed in *Table 2: SPAN-Compatible IMUs* on page 30.
- GNSS antenna

The GNSS receiver is connected to the IMU with an RS-232, RS-422 or SPI link. A NovAtel GNSS antenna must also be connected to the receiver to track GNSS signals. After the IMU enclosure, GNSS antenna and appropriate power supplies are attached, and a few simple configuration commands are entered, the SPAN system will be ready to navigate.

## 1.1 Fundamentals of GNSS+INS

GNSS positioning observes range measurements from orbiting GNSS satellites. From these observations, the receiver can compute position and velocity with high accuracy. NovAtel GNSS positioning systems are highly accurate positioning tools. However, GNSS in general has some restrictions which limit its usefulness in some situations. GNSS positioning requires line of sight view to at least four satellites simultaneously. If these criteria are met, differential GNSS positioning can be accurate to within a few centimeters. If however, some or all of the satellite signals are blocked, the accuracy of the position reported by GNSS degrades substantially, or may not be available at all.

In general, an INS uses forces and rotations measured by an IMU to calculate position, velocity and attitude. This capability is embedded in the firmware of OEM7 receivers. Forces are measured by accelerometers in three perpendicular axes within the IMU and the gyros measure angular rotation rates around those axes. Over short periods of time, inertial navigation gives very accurate acceleration, velocity and attitude output. The INS must have prior knowledge of its initial position, initial velocity, initial attitude, Earth rotation rate and gravity field. Since the IMU measures changes in orientation and acceleration, the INS determines changes in position and attitude, but initial values for these parameters must be provided from an external source. Once these parameters are known, an INS is capable of providing an autonomous solution with no external inputs. However, because of errors in the IMU measurements that accumulate over time, an inertial-only solution degrades with time unless external updates such as position, velocity or attitude are supplied.

The SPAN system's combined GNSS+INS solution integrates the raw inertial measurements with all available GNSS information to provide the optimum solution possible in any situation. By using the high accuracy GNSS solution, the IMU errors can be modeled and mitigated. Conversely, the continuity and relative accuracy of the INS solution enables faster GNSS signal reacquisition and RTK solution convergence.

The advantages of using SPAN technology are its ability to:

- Provide a full attitude solution (roll, pitch and azimuth)
- Provide continuous solution output (in situations when a GNSS-only solution is impossible)
- Provide faster signal reacquisition and RTK solution resolution (over stand-alone GNSS because of the tightly integrated GNSS and INS filters)
- Output high-rate (up to the IMU data rate depending on your logging selections) position, velocity and attitude solutions for high-dynamic applications, see also *Logging Restriction Important Notice* on page 102
- Use raw phase observation data (to constrain INS solution drift even when too few satellites are available for a full GNSS solution)



For more information about GNSS and INS, refer to *An Introduction to GNSS* available on our website at [novatel.com/an-introduction-to-gnss](http://novatel.com/an-introduction-to-gnss)

## 1.2 Models and Features

All SPAN system receivers are factory configurable for L1/L2 RTK capability and are compatible with an IMU. Each model is capable of multiple positioning modes of operation.

The SPAN features enabled on a receiver are identified in the 10<sup>th</sup> and 11<sup>th</sup> characters of the OEM7 model string. For example, if the model string is FFNRNNTBNS**S1**, the characters **S1** identify the SPAN features. If the 10<sup>th</sup> and 11<sup>th</sup> characters are not present in the model number, SPAN has not been enabled on the receiver.



The model string is viewed using the **VERSION** log.

The SPAN features can also be viewed using the **MODELFEATURES** log.

The 10<sup>th</sup> character (S in this example) identifies the INS Options. The 11<sup>th</sup> character (1 in this example) identifies the IMU grade.

### 1.2.1 INS Options

The INS Model character indicates which features are enabled by the model. The INS options are explained in *Table 1: INS Options* below.

**Table 1: INS Options**

INS Model	Meaning	Description	Functionality Inheritance
S	SPAN Enabled	Standard SPAN functionality. This model enables most SPAN functionality.	S

INS Model	Meaning	Description	Functionality Inheritance
P	Enhanced Profiles	Allows the use of enhanced INS profiles for certain applications. For example, dead reckoning performance is controlled using the LAND Profile and Heave filter output is controlled using the MARINE Profile.  For information about INS Profiles, see <i>INS Profiles</i> on page 84. For information about enabling and disabling INS Profiles, see the <b>SETINSPROFILE</b> command.	S+P
R	Relative INS	Allows for two SPAN systems to communicate and produce a relative solution (position, velocity, attitude) between them. This option also inherits the enhanced profile functionality of the P model. For more information, see <i>Relative INS</i> on page 127	S+P+R

### 1.2.2 IMU Grade

The IMU grade indicates which classes of IMUs are supported by the model. The IMU grade is specified as a number between 1 and 3 to indicate the IMU grade available to the model.

So, for example, to use an ISA-100C IMU, an IMU grade of 3 is required. A larger number also allows use of any IMU in a lower grade. So the S3 model required for the ISA-100C would also allow the use of any IMU in grades 1 and 2.

Table 2: *SPAN-Compatible IMUs* below shows the IMU grade classification.

**Table 2: SPAN-Compatible IMUs**

Supported IMUs		
IMU Grade	NovAtel Part Name	IMU Name
1	IMU-CPT	KVH CPT IMU
	IMU-H1930-CA50	Honeywell HG1930-CA50
	IMU-IGM-A1	Analog Devices ADIS16488
	OEM-IMU-ADIS-16488	
	IMU-IGM-S1	Sensoror STIM300
	OEM-IMU-STIM300	
	OEM-IMU-EG320N	Epson G320N
	OEM-IMU-EG370N	Epson G370N
	OEM-IMU-HG4930	Honeywell HG4930-AN01

Supported IMUs		
IMU Grade	NovAtel Part Name	IMU Name
2	IMU-H1900-CA50	Honeywell HG1900-CA50
	IMU-H58	Honeywell HG1700-AG58
	UIMU-H58	
	IMU-H62	Honeywell HG1700-AG62
	UIMU-H62	
	IMU-KVH1750	KVH 1750 IMU
	IMU- $\mu$ IMU	Litef $\mu$ IMU-IC
3	IMU-FSAS-EI	IMAR iIMU-FSAS
	IMU-ISA-100C	Litef ISA-100C
	OEM-IMU-ISA-100C	
	IMU-LN200	Northrop Grumman LN200/LN200C

### 1.3 Related Documents and Information

This manual contains information about the installation and operation of the SPAN system. It is beyond the scope of this manual to provide details on service or repair. Contact your local NovAtel dealer for any customer service related inquiries, see *Customer Support* on page 24.

The OEM7 receiver utilizes a comprehensive user-interface command structure, which requires communications through its communications ports. For descriptions of the commands and logs available with OEM7 receivers, refer to the [OEM7 Commands and Logs Reference Manual](#) or [Agriculture Commands and Logs Reference Manual](#) available on the NovAtel website at [novatel.com/support](http://novatel.com/support). It is recommended that these documents be kept together for easy reference.

For more information about the OEM7 receivers, refer to the [OEM7 Installation and Operation User Manual](#), [CPT7 Installation and Operation User Manual](#), [PwrPak7 Installation and Operation User Manual](#) or [SMART7 Installation and Operation User Manual](#).

SPAN system output is compatible with post-processing software from NovAtel's Waypoint Products Group. Visit our web site at [novatel.com/products/waypoint-software](http://novatel.com/products/waypoint-software) for details.

## Chapter 2 SPAN Installation

A SPAN system consists of an OEM7 receiver, an IMU, a GNSS antenna, power and a communication link (if your application requires real time differential operation). The installation process varies based on the OEM7 receiver.

- *OEM7 Receiver Card Installation* on the next page
- *PwrPak7 Installation* on page 72
- *PwrPak7-E1/PwrPak7-E2 Installation* on page 75



If your IMU enclosure and IMU were supplied separately, additional instructions for installing the IMU into an enclosure are available in the following appendices: *HG1700 IMU in Universal Enclosure* on page 283, *LN-200 IMU in Universal Enclosure* on page 292, *HG1700 IMU in SPAN HG Enclosure* on page 299 and *LN-200 IMU in SPAN IMU Enclosure* on page 305.



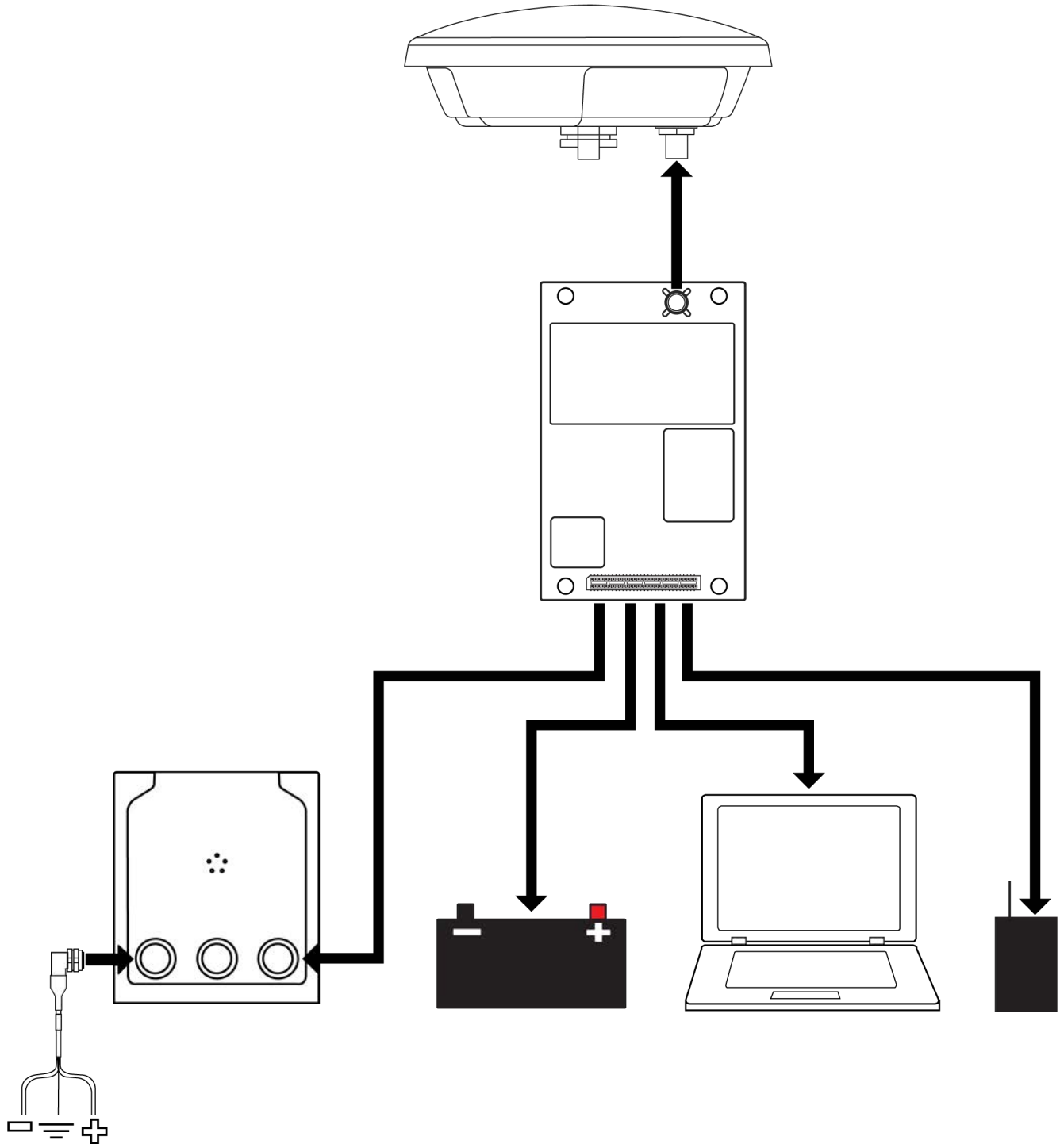
For information about installing a CPT7, refer to [CPT7 Installation and Operation User Manual](#)  
For information about installing a SMART7-S, refer to [SMART7 Installation and Operation User Manual](#)



## 2.1 OEM7 Receiver Card Installation

The following diagram shows a typical SPAN installation using an OEM7 receiver card and an IMU in an enclosure.

**Figure 1: Typical Installation of a SPAN System with an OEM7 Receiver Card**



Complete the following steps to set up your NovAtel SPAN system.

1. Mount the GNSS antenna.  
See *Mounting the GNSS Antenna* on the next page for details.
2. Mount the IMU.  
See *Mount the IMU* on page 36 for details.
3. Install the OEM7 receiver card.  
See the [OEM7 Installation and Operation User Manual](#) for information about installing an OEM7 receiver.
4. Connect the GNSS antenna to the OEM7 receiver card.  
See the [OEM7 Installation and Operation User Manual](#) for information about installing an OEM7 receiver.
5. Connect the IMU to the OEM7 receiver.  
See *Connect the IMU to the OEM7 Receiver Card* on page 38 for details.
6. Connect the I/O strobe signals (optional).  
See the [OEM7 Installation and Operation User Manual](#) for information about installing an OEM7 receiver.
7. Connect power to the IMU and receiver.  
See *Connect Power* on page 55 for details.
8. Connect a data communication device, such as a computer, to the receiver. A data communication device is used to configure and monitor the receiver.  
See the [OEM7 Installation and Operation User Manual](#) for information about installing an OEM7 receiver.

### 2.1.1 Selecting a GNSS Antenna

NovAtel offers a variety of GNSS antennas, including single, dual and triple-frequency, triple-band and wide-band reference antennas (refer to our web site: [novatel.com/products/antennas](http://novatel.com/products/antennas) for details of available antennas). All antennas include band pass filtering and an LNA. The GNSS antenna chosen depends on the particular application. Each model offers exceptional phase center stability and a significant measure of immunity against multipath interference. Each antenna has an environmentally sealed radome and all meet the European Union's Restriction of Hazardous Substances (RoHS) and Waste Electrical and Electronic Equipment (WEEE).

If a non-NovAtel GNSS antenna is chosen, a typical antenna LNA gain between 26 dB to 30 dB is recommended in a rover station application.



A dual frequency capable GNSS antenna is required to use SPAN, RTK, ALIGN or dual frequency GLIDE.  
An L-Band capable antenna is required to receive TerraStar corrections.

For more information about antenna selection, see *Importance of Antenna Selection* on page 314.

### 2.1.2 Choosing a Coaxial Cable

An appropriate coaxial cable matches the impedances of the antenna and receiver (50 ohms) and has a line loss not exceeding 10.0 dB. If the limit is exceeded, excessive signal degradation may occur and the receiver may not meet performance specifications. NovAtel offers several coaxial cables to meet GNSS antenna inter-connection requirements, including:

- 5 m, 15 m and 30 m antenna cable with TNC connectors on both ends (NovAtel part numbers GPS-C006, GPS-C016 and GPS-C032)

- 2.5 m and 5 m antenna cable with an SMA connector on one end and a TNC connector on the other (NovAtel part numbers 60723177 and 60723178)



The SMA to TNC cables (60723177 and 60723178) are not recommended for permanent outdoor use.



For more information about antenna cabling, including using cables longer than 30 m and in-line amplifiers, refer to [APN-077: RF Equipment Selection and Installation](#) available from ([nova-tel.com/support/support-materials/application-notes](http://novatel.com/support/support-materials/application-notes)).



NovAtel recommends using high quality coaxial cables because an impedance mismatch is possible when using lower quality cables and this produces reflections in the cable that increases signal loss. Although other high quality antenna cables can be used, the performance specifications of the OEM7 receivers are warranted only when used with NovAtel supplied accessories.

### 2.1.3 Mounting the GNSS Antenna

The OEM7 receiver is designed to operate with any NovAtel GNSS antenna. See *Selecting a GNSS Antenna* on the previous page for more information.

When installing the antenna:

- Choose an antenna location with a clear view of the sky so each satellite above the horizon can be tracked without obstruction. For more information on RF signal propagation and multipath, refer to the NovAtel application note [APN-008: Discussions on RF Signal Propagation and Multipath](#) at [novatel.com/support/support-materials/application-notes](http://novatel.com/support/support-materials/application-notes).
- Mount the antenna on a secure, stable structure capable of safe operation in the specific environment.
- Ensure the antenna cannot move due to dynamics.
- For dual antenna systems only  
Heading accuracy is dependent on antenna baseline length. Mount the primary and secondary antennas as far apart as possible. A minimum separation distance of 1 meter is recommended.

For more detailed information about GNSS antenna installation, refer to [APN-077: RF Equipment Selection and Installation](#) at [novatel.com/support/support-materials/application-notes](http://novatel.com/support/support-materials/application-notes).

#### Antenna LNA Power

NovAtel antennas and coaxial cables meet receiver RF input gain requirements. NovAtel coaxial cables are designed to introduce no more than 10 dB loss and NovAtel antennas are equipped with built-in LNAs that provide 29 dB of gain to the satellite signal received.

The power to the antenna LNA is provided through the receiver's RF port center conductor.

Antenna supply over current protection limits the LNA power.



If a short circuit or other problem causes an overload of the current supplied to the antenna, the receiver hardware shuts down the power supplied to the antenna. To restore power, power cycle the receiver. The Receiver Status word, available in the **RXSTATUS** log (see [OEM7 Commands and Logs Reference Manual](#)), provides more information about the cause of the problem.

### 2.1.4 Mount the IMU

Mount the IMU in a fixed location where the distance from the IMU to the GNSS antenna phase center is constant. Ensure that the orientation with respect to the vehicle and antenna is also constant.

For attitude output to be meaningful, the IMU should be mounted such that the positive Z-axis marked on the IMU enclosure points up and the Y-axis points forward through the front of the vehicle, in the direction of track. If the IMU is not mounted in this orientation, a rotational offset must be applied. See *Rotational Offsets* on page 82 for more information.

Also, it is important to measure the distance from the IMU to the antenna (the Antenna Lever Arm), on the first usage, on the axis defined on the IMU enclosure. See *Lever Arm Calibration Routine* on page 102. See also *IMU Technical Specifications* on page 135 for dimensional drawings of the IMU enclosures.

Ensure the IMU cannot move due to dynamics and that the distance and relative direction between the antenna and the IMU is fixed. See *SPAN Configuration for Receiver Cards* on page 85.



The closer the antenna is to the IMU, particularly in the horizontal plane, the more accurate the position solution.

Also, your measurements entered using the **SETINSTRANSLATION** command must be as accurate as possible, or at least more accurate than the GNSS positions being used. **For example, a 10 cm error in recording the antenna offset will result in at least a 10 cm error in the output. Millimeter accuracy is preferred.**

The offset from the IMU to the antenna, and/or a user point device, must remain constant especially for RTK or DGPS data. Ensure the IMU, antenna and user point device are bolted in one position perhaps by using a custom bracket.

#### Securing the IMU Enclosure

The IMU Enclosure (IMU-ISA-100C, IMU-ENC-LN200, IMU-HG1900 and IMU- $\mu$ IMU-IC) can be secured directly to the mounting surface or can be secured using the IMU Enclosure Mounting Plate.

To secure the IMU Enclosure directly to the mounting surface, use four M6 screws that pass through the mounting surface and into the bottom of the IMU Enclosure. For the location and spacing of the mounting holes, refer to the mechanical drawings of the IMU in *IMU Technical Specifications* on page 135.



The optimal screw penetration into the IMU Enclosure mounting holes is 5.0 to 6.0 mm deep. When selecting screws for mounting the IMU Enclosure, ensure the screw penetration does not exceed 6 mm. Using excessively long screws can damage the IMU Enclosure.



The mounting screws should be torqued to 42 to 45 in-lbs.

For information about securing the IMU Enclosure using the mounting plate, refer to *Secure an IMU Enclosure Using the Mounting Plate* below.



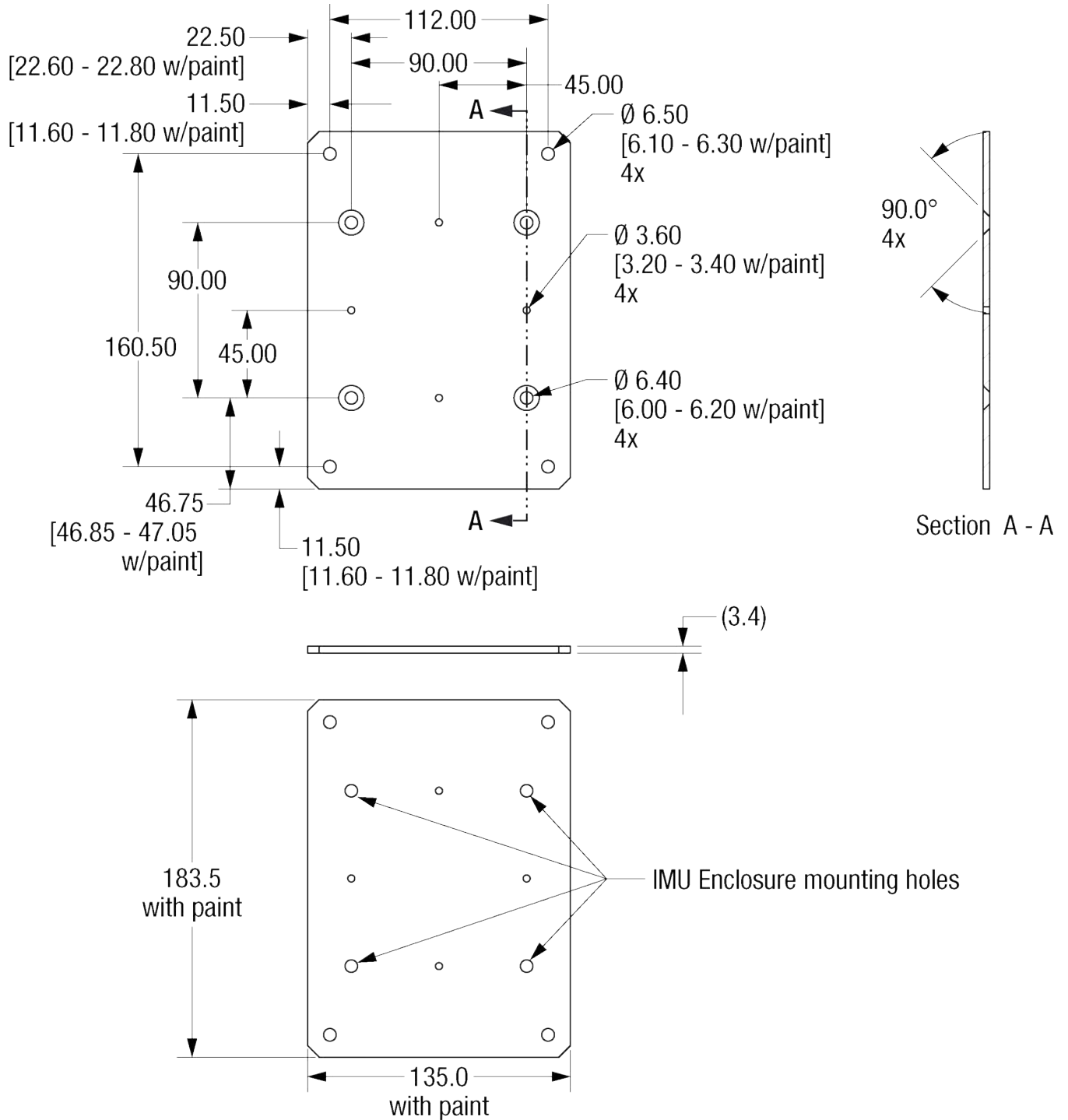
Other IMUs are secured using the four through holes in the base of the IMU.

#### Secure an IMU Enclosure Using the Mounting Plate

To secure an IMU enclosure using the IMU Enclosure Mounting Plate:

1. Place the mounting plate on the bottom of the IMU Enclosure and align the holes in the mounting plate with the threaded holes in the IMU Enclosure base plate.
2. Secure the mounting plate to the IMU Enclosure using the 4 screws (M6 x 8 mm) included with the mounting plate.
3. Secure the IMU Enclosure mounting plate to the mounting location using 4 M6 screws.

**Figure 2: IMU Enclosure Mounting Plate**



### 2.1.5 Connect the IMU to the OEM7 Receiver Card

The method used to connect the IMU depends on the IMU and OEM7 receiver in the system. IMUs that are contained within an IMU enclosure communicate with the OEM7 receiver using a serial port. IMUs not contained in an IMU enclosure communicate with the OEM7 receiver either through an interface card (MIC or UIC) or direct connection (SPI or Serial).

IMUs in an enclosure typically have *IMU* or *UIMU* at the start of their names (for example, IMU-ISA-100C, IMU- $\mu$ IMU-IC or IMU-IGM-S1).

IMUs not in an IMU enclosure typically have *OEM* at the start of their names (for example, OEM-IMU-ISA-100C, OEM-IMU- $\mu$ IMU or OEM-IMU-STIM300).

**Table 3: IMU Connection Method**

IMU	Receiver	Connection Method
IMU-H58/62	OEM719, OEM729, OEM7600, OEM7700, OEM7720, PwrPak7	Serial port (RS-422)
IMU-CPT	OEM719, OEM729, OEM7600, OEM7700, OEM7720, PwrPak7	Serial port (RS-422)
IMU-FSAS	OEM719, OEM729, OEM7600, OEM7700, OEM7720, PwrPak7	Serial port (RS-422)
IMU-HG1900	OEM719, OEM729, OEM7600, OEM7700, OEM7720, PwrPak7	Serial port (RS-422)
IMU-IGM-A1	OEM719, OEM729, OEM7600, OEM7700, OEM7720, PwrPak7	Serial port (RS-232 or RS-422)
IMU-IGM-S1	OEM719, OEM729, OEM7600, OEM7700, OEM7720, PwrPak7	Serial port (RS-232 or RS-422)
IMU-ISA-100C	OEM719, OEM729, OEM7600, OEM7700, OEM7720, PwrPak7	Serial port (RS-422)
IMU-KVH-1750	OEM719, OEM729, OEM7600, OEM7700, OEM7720, PwrPak7	Serial port (RS-422)
IMU-ENC-LN200	OEM719, OEM729, OEM7600, OEM7700, OEM7720, PwrPak7	Serial port (RS-422)
IMU- $\mu$ IMU-IC	OEM719, OEM729, OEM7600, OEM7700, OEM7720, PwrPak7	Serial port (RS-422)
IMU-LN200	OEM719, OEM729, OEM7600, OEM7700, OEM7720, PwrPak7	Serial port (RS-422)
OEM-IMU-ADIS16488	OEM719, OEM729, OEM7600, OEM7700, OEM7720, PwrPak7	MIC
	OEM7600, OEM7700, OEM7720	SPI port
OEM-IMU-EG320N	OEM7600, OEM7700, OEM7720	SPI port

IMU	Receiver	Connection Method
OEM-IMU-EG370N	OEM7600, OEM7700, OEM7720	SPI port
OEM-IMU-HG1900	OEM719, OEM729, OEM7600, OEM7700, OEM7720, PwrPak7	MIC
OEM-IMU-HG1930	OEM719, OEM729, OEM7600, OEM7700, OEM7720	MIC
OEM-IMU-HG4930	OEM719, OEM729, OEM7600, OEM7700, OEM7720, PwrPak7	Serial port (TTL)
OEM-IMU-ISA-100C	OEM719, OEM729, OEM7600, OEM7700, OEM7720	UIC
OEM-IMU-STIM300	OEM719, OEM729, OEM7600, OEM7700, OEM7720, PwrPak7	MIC
		Serial port (RS-422)
OEM-IMU- $\mu$ IMU	OEM719, OEM729, OEM7600, OEM7700, OEM7720, PwrPak7	UIC
UIMU-HG1700 (H58 & H62)	OEM719, OEM729, OEM7600, OEM7700, OEM7720, PwrPak7	Serial port (RS-422)
UIMU-LN200	OEM719, OEM729, OEM7600, OEM7700, OEM7720, PwrPak7	Serial port (RS-422)

### Connect an IMU Enclosure to an OEM7 Receiver Card Using a Serial Port

An interface is needed between the OEM7 receiver card and IMU that provides:

- Communication signals to the OEM7 receiver
- A serial port connection between the IMU and receiver
- Power to the receiver
- Power to the IMU

For information about the interface requirements for the OEM7 receiver card, see the [OEM7 Installation and Operation User Manual](#).

For information about the interface to the IMU, refer to the technical specifications of the IMU in *IMU Technical Specifications* on page 135.

**IMU-CPT, IMU-KVH1750 and IMU-FSAS**

These IMUs require an additional output from the receiver to synchronize the IMU and receiver.

- IMU-CPT

Connect the EVENT\_OUT1 (VARF) signal from the receiver to the External Clock Input signal (pin 36) on the IMU-CPT. Refer to the *IMU-CPT Cable* on page 146 for information about the cable requirements for the IMU-CPT.

- IMU-KVH1750

Connect the EVENT\_OUT1 (VARF) signal from the receiver to the MSync signal (pin 11) on the IMU-KVH1750. Refer to the *IMU-KVH1750 Cable* on page 189 for information about the cable requirements for the IMU-KVH1750.

- IMU-FSAS

Connect the EVENT\_OUT1 (VARF) signal from the receiver to the DAS(+) signal (pin 7) on the IMU-FSAS. Refer to the *IMU-FSAS Cable with Wheel Sensor* on page 153 for information about the cable requirements for the IMU-FSAS.

- OEM-IMU-STIM300D

Connect the EVENT\_IN2 signal from the receiver to the TOV signal (pin 4) on the OEM-IMU-STIM300. Refer to *OEM-IMU-STIM300 Direct Connection* on page 238 for more information.

**OEM-IMU-STIM300D**

The OEM-IMU-STIM300D requires an additional input from the receiver to synchronize the IMU and receiver.

Connect the EVENT\_IN2 signal from the receiver to the TOV signal (pin 4) on the OEM-IMU-STIM300. Refer to *OEM-IMU-STIM300 Direct Connection* on page 238 for more information.



The interface between the OEM7 receiver card and IMU must include circuitry to convert from the LVCMOS signal levels of the receiver COM port to the RS-232 or RS-422 signal levels of the IMU COM port.

The exception is COM1 on the OEM729 which provides either RS-232 or RS-422 signal levels.



If using a KVH1750 IMU not purchased through NovAtel, the baud rate of the IMU must be changed to 460,800 bps and the output method changed to MSYNC,EXT. For information about changing these parameters, see *KVH1750 Baud Rate Conversion* on page 54.

**Connect an OEM IMU to an OEM7 Receiver Card Using a UIC**

The UIC provides power to the IMU and communication between the IMU and receiver. For information about using a UIC, see *UIC Installation* on page 68.

**Connect an OEM IMU to an OEM7 Receiver Card Using a MIC**

The MIC provides power to the IMU and communication between the IMU and receiver. For information about using a MIC, see *MIC Installation* on page 57.



## Connect an OEM IMU to an OEM7 Receiver Card Using a Direct Connection

Some OEM IMUs can communicate with the OEM7 receiver card without using an interface card. For information about using a direct connection, see:

- *Connect an OEM-IMU-ADIS-16488 Directly to an OEM7 Receiver Card* below
- *Connect an OEM-IMU-EG320N or OEM-IMU-EG370N Directly to an OEM7 Receiver Card* on page 44
- *Connect an OEM-IMU-STIM300 Directly to an OEM7 Receiver* on page 46
- *Connect an OEM-IMU-HG4930 Directly to an OEM7 Receiver* on page 49

## Connect an OEM-IMU-ADIS-16488 Directly to an OEM7 Receiver Card

The OEM-IMU-ADIS-16488 can connect directly to SPI capable OEM7 receivers, such as the OEM7600, OEM7700 and OEM7720, using a SPI connection. The SPI connection handles timing and data communication between the receiver and IMU.



The OEM-IMU-ADIS-16488 can also connect to any OEM7 receiver using a MEMS Interface Card (MIC). For information about using a MIC, see *MIC Installation* on page 57.

The interface to the OEM-IMU-ADIS-16488 must provide:

- a Samtec CLM-112-02 connector

This connector mates with the connector on the OEM-IMU-ADIS-16488. See *Figure 3: OEM-IMU-ADIS-16488 Pin Locations* on the next page for the location of the IMU connector and pins.

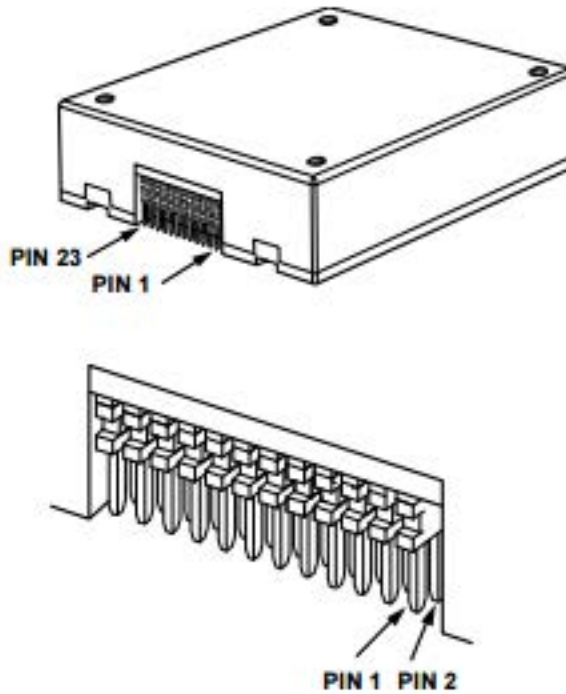
- a SPI port connection to the OEM7 receiver

Refer to the following table for the connections required between the IMU and receiver. For information about the receiver connector, see the [OEM7 Installation and Operation User Manual](#).

- a 3.3 VDC ( $\pm 0.3$  VDC) regulated power supply

Refer to the following table for the location of the power supply connections.

**Figure 3: OEM-IMU-ADIS-16488 Pin Locations**



**Table 4: Receiver to ADIS-16488 Pin Connections**

ADIS-16488		Receiver		
Pin	Pin Name	Pin	Pin Name	Description
1	NC	–	–	Do not connect
2	NC	–	–	Do not connect
3	SCLK	44	SPI_SCLK	SPI Serial Clock
4	SDO	43	SPI_MISO	SPI Data Output
5	SDI	41	SPI_MOSI	SPI Data Input
6	/CS	42	SPI_nCS	SPI Chip Select
7	DIO1	26	EVENT_OUT2	Synchronization signal

ADIS-16488		Receiver		
Pin	Pin Name	Pin	Pin Name	Description
8	/RST	–	–	<p>Reset IMU</p> <p>RST must be high for the IMU to be active.</p> <p>To enable the IMU when the receiver is powered on, connect this pin to Pin 1 or Pin 2 of the receiver interface connector through a 10 kΩ resistor (recommended).</p> <p>Can also connect this pin to any stable 3.3 VDC power supply or output configuration to have more control over when IMU is enabled. When using this configuration note that:</p> <ul style="list-style-type: none"> <li>pin 8 must be pulled low for greater than 100 ms to properly soft-reset the IMU</li> <li>pin has an internal pull-up resistor</li> </ul>
9	DIO2	29	EVENT_IN2	Data ready
10	VDD	–	–	3.3 VDC power supply
11	VDD	–	–	3.3 VDC power supply
12	VDD	–	–	3.3 VDC power supply
13	GND	–	–	Digital ground
14	GND	–	–	Digital ground
15	GND	–	–	Digital ground
16	NC	–	–	Do not connect
17	NC	–	–	Do not connect
18	NC	–	–	Do not connect
19	NC	–	–	Do not connect
20	NC	–	–	Do not connect
21	NC	–	–	Do not connect
22	NC	–	–	Do not connect
23	NC	–	–	Do not connect
24	NC	–	–	Do not connect



For the location of the receiver pins, refer to the [OEM7 Installation and Operation User Manual](#).

For more information about the OEM-IMU-ADIS-16488, see *OEM-IMU-ADIS-16488* on page 206.

## Connect an OEM-IMU-EG320N or OEM-IMU-EG370N Directly to an OEM7 Receiver Card



The information in this section applies to the OEM-IMU-EG320N (EG320N) and the OEM-IMU-EG370N (EG370N).

The EG320N and EG370N can connect directly to SPI capable OEM7 receivers, such as the OEM7600, OEM7700 or OEM7720, using a SPI connection. The SPI connection handles timing and data communication between the receiver and IMU.

The interface to the EG320N or EG370N must provide:

- a Samtec CLM-110-02-H-D connector

This connector mates with the connector on the EG320N/EG370N. See *Figure 4: EG320N/EG370N Pin Locations* below for the location of the IMU connector and pins.

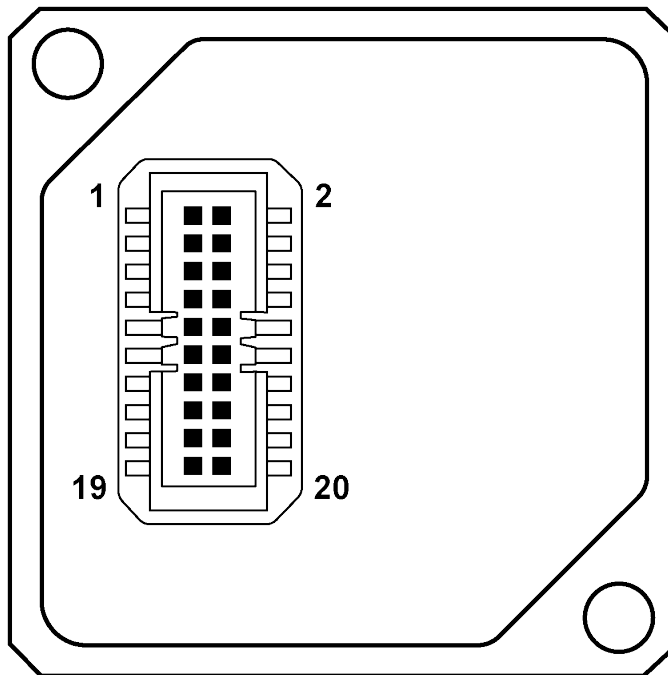
- a SPI port connection to the OEM7 receiver

See *Table 5: Receiver to EG320N/EG370N Pin Connections* on the next page for the connections required between the IMU and receiver. For information about the receiver connector, see the [OEM7 Installation and Operation User Manual](#).

- a 3.3 VDC ( $\pm 0.15$  VDC) regulated power supply

See *Table 5: Receiver to EG320N/EG370N Pin Connections* on the next page for the location of the power supply connections.

**Figure 4: EG320N/EG370N Pin Locations**



**Table 5: Receiver to EG320N/EG370N Pin Connections**

EG320N/EG370N		Receiver		
Pin	Pin Name	Pin	Pin Name	Description
1	SCLK	44	SPI_SCLK	SPI Serial Clock
2	SDO	43	SPI_MISO	SPI Data Output
3	GND	–	–	Digital ground
4	GND	–	–	Digital ground
5	SDI	41	SPI_MOSI	SPI Data Input
6	/CS	42	SPI_nCS	SPI Chip Select
7	SOUT	–	–	UART Data Out Connect to the 3.3 VDC power supply through a resistor (default 10 kΩ).
8	GND	–	–	Digital ground
9	SIN	–	–	UART Data In Connect to the 3.3 VDC power supply through a resistor (default 10 kΩ).
10	VCC	–	–	3.3 VDC power supply
11	VCC	–	–	3.3 VDC power supply
12	VCC	–	–	3.3 VDC power supply
13	DRDY (GPIO1)	29	EVENT_IN2	Data Ready
14	GPIO2 (EXT)	26	EVENT_OUT2	External Trigger
15	GND	–	–	Digital ground

EG320N/EG370N		Receiver		Description
Pin	Pin Name	Pin	Pin Name	
16	/RST	–	–	<p>Reset IMU</p> <p>RST must be high for the IMU to be active.</p> <p>To enable the IMU when the receiver is powered on, connect this pin to Pin 1 or Pin 2 of the receiver connector through a 10 kΩ resistor (recommended).</p> <p>Can also connect this pin to any stable 3.3 VDC power supply or output configuration to have more control over when IMU is enabled. When using this configuration note that:</p> <ul style="list-style-type: none"> <li>pin 16 must be pulled low for greater than 100 ms to properly soft-reset the IMU</li> <li>pin 16 has an internal 32-224 kΩ pull-up resistor</li> </ul>
17	NC	–	–	Do not connect
18	NC	–	–	Do not connect
19	NC	–	–	Do not connect
20	NC	–	–	Do not connect



For the location of the receiver pins, refer to the [OEM7 Installation and Operation User Manual](#).

For more information about the EG320N, see *OEM-IMU-EG320N* on page 214. For information about the EG370N, see *OEM-IMU-EG370N* on page 219.

### Connect an OEM-IMU-STIM300 Directly to an OEM7 Receiver

The OEM-IMU-STIM300 can connect directly to an OEM7 receiver using a serial port connection.



The OEM-IMU-STIM300 serial port uses RS-422 signal levels. Since most OEM7 receiver card ports use LVCMOS signal levels, a RS-422 line driver is needed to convert from LVCMOS to RS-422. The exception is COM1 on the OEM729 that operates at RS-232 or RS-422 levels.



The OEM-IMU-STIM300 can also connect to any OEM7 receiver using a MEMS Interface Card (MIC). For information about using a MIC, see *MIC Installation* on page 57.

The interface to the OEM-IMU-STIM300 must provide:

- a Micro-D 15 pin male connector

This connector mates with the connector on the OEM-IMU-STIM300. See *Figure 5: OEM-IMU-STIM300 Pin Out* on the next page for the IMU connector pin out.

- a RS-422 serial port connection to the OEM7 receiver

For most OEM7 receiver cards the connection must include a RS-422 line driver.

If using COM1 on an OEM729, a RS-422 line driver is not required. However, the COM1 protocol must be set to RS-422 using the **SERIALPROTOCOL** command.

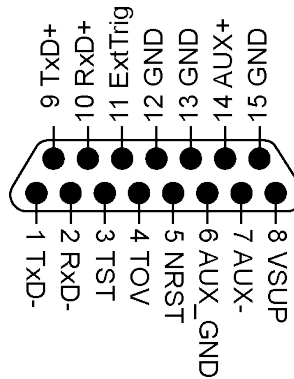
Use COM1 or COM2 on the PwrPak7 to connect to the OEM-IMU-STIM300. These ports can be set to RS-422 protocol using the **SERIALPROTOCOL** command.

Refer to the following table for the connections required between the IMU and receiver. For information about the receiver connector, see the [OEM7 Installation and Operation User Manual](#).

- a 5.0 VDC (±0.5 VDC) regulated power supply

Refer to the following table for the location of the power supply connections.

**Figure 5: OEM-IMU-STIM300 Pin Out**



**Table 6: OEM7 Receiver Card to STIM300 Pin Connections**


Pin	STIM300		RS-422 Line Driver		Receiver	
	Pin Name	Output	Input	Pin Name	Description	
1	STIM TXD-	RS422 B-	–	–	Part of RS-422 transmit pair from STIM300	
2	STIM RxD-	RS422 A-	–	–	Part of RS-422 receive pair from STIM300	
3	NC	–	–	–	Do not connect	
4	STIM TOV	–	–	EVENT_IN2 OEM719: 7 OEM729: 7 OEM7600 : 29 OEM7700: 29 OEM7720: 29	<div style="border: 1px solid black; padding: 5px;"> <p><b>Interface Circuit Required</b></p> <p>The STIM TOV output uses 5V logic, but the OEM7 EVENT_IN lines are not 5V tolerant. A circuit to convert from 5V logic to 3.3V levels is required.</p> </div>	
5	NC	–	–	–		Do not connect

STIM300		RS-422 Line Driver		Receiver	
Pin	Pin Name	Output	Input	Pin Name	Description
6	NC	–	–	–	Do not connect
7	NC	–	–	–	Do not connect
8	5V Pwr	–	–	–	5 VDC power supply
9	STIM TxD+	RS422 B+	–	–	Part of RS-422 transmit pair from STIM300
10	STIM RxD+	RS422 A+	–	–	Part of RS-422 receive pair from STIM300
11	NC	–	–	–	Do not connect
12	GND	–	–	–	Any receiver ground pin
13	GND	–	–	–	Any receiver ground pin
14	NC	–	–	–	Do not connect
15	GND	–	–	–	Any receiver ground pin
–	–	–	LVC MOS A IN	COMx_TXD	Any receiver COM port transmit and receive pair
–	–	–	LVC MOS B IN	COMx_RXD	
–	–	–	GND	–	Any receiver ground pin

Table 7: OEM729 COM1 or PwrPak7 to STIM300 Pin Connections

STIM300		Receiver		Description
Pin	Pin Name	Pin	Pin Name	
1	STIM TXD-	OEM729 COM1: 15 PwrPak7 COM1: 4 COM2: 12	COMx_ RXD-	Part of RS-422 transmit pair from STIM300
2	STIM RxD-	OEM729 COM1: 17 PwrPak7 COM1: 1 COM2: 19	COMx_ TXD-	Part of RS-422 receive pair from STIM300
3	NC	–	–	Do not connect



STIM300		Receiver		
Pin	Pin Name	Pin	Pin Name	Description
4	STIM TOV	OEM729: 7 PwrPak7: 23	EVENT_IN2	<div style="border: 1px solid black; padding: 5px;">  <p><b>Interface Circuit Required</b> The STIM TOV output uses 5V logic, but the OEM729 EVENT_IN lines are not 5V tolerant. A circuit to convert from 5V logic to 3.3V levels is required on the OEM729.</p> </div> <p>The PwrPak7 input strobes are 5V tolerant and can be connected directly to the STIM TOV output.</p>
5	NC	–	–	Do not connect
6	NC	–	–	Do not connect
7	NC	–	–	Do not connect
8	5V Pwr	–	–	5 VDC power supply
9	STIM TxD+	OEM729 COM1: 18 PwrPak7 COM1: 3 COM2: 20	COMx_ RXD+	Part of RS-422 transmit pair from STIM300
10	STIM RxD+	OEM729 COM1: 20 PwrPak7 COM1: 2 COM2: 10	COMx_ TXD+	Part of RS-422 receive pair from STIM300
11	NC	–	–	Do not connect
12	GND			Any receiver ground pin
13	GND			Any receiver ground pin
14	NC	–	–	Do not connect
15	GND			Any receiver ground pin



For the location of the receiver ground pins and transmit and receive pairs, refer to the [OEM7 Installation and Operation User Manual](#) or [PwrPak7 Installation and Operation User Manual](#).

### Connect an OEM-IMU-HG4930 Directly to an OEM7 Receiver

The OEM-IMU-HG4930 can connect directly to an OEM7 receiver using a serial port connection.



The OEM-IMU-HG4930 serial port uses 5 V signal levels. OEM7 receiver card COM ports are not 5 V tolerant. A circuit to convert from 5V logic to 3.3V levels is required.



SPAN supports the Honeywell HG4930-AN01 model only. Other models of the HG4930 are not supported.

The interface to the OEM-IMU-HG4930 must provide:

- a 2 x 7 header

This connector mates with the connector on the OEM-IMU-HG4930. The recommended connectors are:

**Table 8: OEM-IMU-HG4930 Mating Connector**

OEM-IMU-HG4930 Connector	Mating Connector
2 x 7 header	SAMTEC CLT-107-01-S-D
	DigiKey CLT-107-01-S-D-ND

- an interface circuit between the OEM-IMU-HG4930 and the OEM7 receiver

For most OEM7 receiver card COM ports, a circuit is required to convert from the 5 V levels used by the OEM-IMU-HG4930 to the 3.3 V levels used by the receiver.

For COM1 on the OEM729, a line driver is required for the COM port connection to convert from the 5 V levels on the OEM-IMU-HG4930 to RS-232 or RS-422. If using a RS-422 line driver, change the protocol of the receiver COM port to RS-422 using the **SETIMU** **PORTPROTOCOL** command.

Refer to the following tables for the connections required between the IMU and receiver. For information about the receiver connector, see the [OEM7 Installation and Operation User Manual](#).


- a 5.0 VDC (±0.5 VDC) regulated power supply

Refer to the following tables for the location of the power supply connections.

**Direct Connect an OEM7 Receiver to the OEM-IMU-HG4930**

**Table 9: OEM7 Receiver Card to HG4930 Pin Connections**

HG4930		Receiver	
Pin	Pin Name	Pin Name	Description
1	GND	–	Connect to power supply Ground and any receiver ground pin. Follow grounding best practices.
2	+5V	–	Connect to the 5 VDC power supply

HG4930		Receiver	
Pin	Pin Name	Pin Name	Description
3	TMI	PPS	OEM719: Pin 19 OEM729: Pin 4 OEM7600: Pin 24 OEM7700: Pin 24 OEM7720: Pin 24
4	NC	–	Do not connect
5	NC	–	Do not connect
6	NC	–	Do not connect
7	NC	–	Do not connect
8	NC	–	Do not connect
9	NC	–	Do not connect
10	NC	–	Do not connect
11	TTL_TX	COMx_RXD	<p>Any COM port transmit and receive pair.</p> <div style="border: 1px solid black; padding: 5px;">  <p>For most COM ports, a circuit to convert from 3.3V to 5V levels is required. The exception is COM1 on the OEM729. For COM1 on the OEM729, see <i>Direct Connect COM1 on the OEM729 to the OEM-IMU-HG4930</i> on the next page.</p> </div>
12	TTL_RX	COMx_TXD	
13	NC	–	Do not connect
14	NC	–	Do not connect

Enter the following commands on the OEM7 receiver to configure the receiver to use the direct connection to the HG4930 described in the previous table.

1. `CONNECTIMU COMx HG4930_AN01`
2. `PPSCONTROL ENABLE POSITIVE`

**Direct Connect COM1 on the OEM729 to the OEM-IMU-HG4930****Table 10: COM1 on the OEM729 to HG4930 Pin Connections**

HG4930		Receiver	
Pin	Pin Name	Pin Name	Description
1	GND	–	Connect to power supply Ground and any receiver ground pin. Follow grounding best practices.
2	+5V	–	Connect to the 5 VDC power supply
3	TMI	PPS	OEM729: Pin 4
4	NC	–	Do not connect
5	NC	–	Do not connect
6	NC	–	Do not connect
7	NC	–	Do not connect
8	NC	–	Do not connect
9	SER_DATA_OUT_H	COM1_RXD+	OEM729: Pin 18 Serial Data High Output (RS-485)
10	SER_DATA_OUT_L	COM1_RXD-	OEM729: Pin 15 Serial Data Low Output (RS-485)
11	NC	–	Do not connect
12	NC	–	Do not connect
13	NC	–	Do not connect
14	NC	–	Do not connect

Enter the following commands on the OEM7 receiver to configure the receiver to use the direct connection to the HG4930 described in the previous table.

1. CONNECTIMU COM1 HG4930\_AN01
2. PPSCONTROL ENABLE POSITIVE
3. SETIMUPORTPROTOCOL RS422

## Direct Connect a PwrPak7 to the OEM-IMU-HG4930

Table 11: PwrPak7 to HG4930 Pin Connections

HG4930 AN01			PwrPak7		
Pin	Pin Name	DSUB HD26 Pin	All I/O SPAN Cable COM2 /IMU DB9 Pin	Pin Name	Description
1	DGND	17	5	COM2_GND	Connect to power supply Ground and any receiver ground pin. Follow grounding best practices.
2	+5VDC	–	–	–	Connect to the 5 VDC power supply
3	TMI	16	1	EVENT_OUT1	PPS Synchronization signal
4	NC	–	–	–	Do not connect
5	NC	–	–	–	Do not connect
6	NC	–	–	–	Do not connect
7	NC	–	–	–	Do not connect
8	NC	–	–	–	Do not connect
9	SER_DATA_OUT_H	20	2	COM2_422RX+	Serial Data High Output (RS-485)
10	SER_DATA_OUT_L	12	8	COM2_422RX-	Serial Data Low Output (RS-485)
11	NC	–	–	–	Do not connect
12	NC	–	–	–	Do not connect
13	NC	–	–	–	Do not connect
14	NC	–	–	–	Do not connect



For the location of the receiver ground pins and transmit and receive pairs, refer to the [OEM7 Installation and Operation User Manual](#) or [PwrPak7 Installation and Operation User Manual](#).

Enter the following commands on the PwrPak7 to configure the receiver to use the direct connection to the HG4930 described in the previous table.

1. CONNECTIMU COM2 HG4930\_AN01
2. SETIMUPORTPROTOCOL RS422
3. EVENTOUTCONTROL MARK1 ENABLE POSITIVE 100000000 900000000

### KVH1750 Baud Rate Conversion

If purchased directly from KVH, the KVH1750 must be configured before it can be used with an OEM7 receiver.

The KVH1750 natively communicates at 921,600 bps, however the maximum baud rate of the COM ports on an OEM7 receiver is 460,800 bps. Thus, KVH1750 IMUs purchased from KVH must be modified to use 460,800 bps. Also, the MSYNC setting on the KVH1750 must be set to EXT.



Though slower, 460,800 bps is more than adequate to transmit the data at the required 200 Hz without any impact to performance.

There are two methods to change the KVH1750 IMU baud rate. If an OEM6 receiver is available, a command is available that will allow the receiver to change the IMU baud rate. If not, a direct RS-422 connection at 921,600 baud is required to change the IMU baud rate.

### Connect Directly to the IMU



This method requires a direct connection to the IMU at 921,600 baud over RS-422. Make sure the RS-422 link used is capable of 921,600 baud as not all serial ports are capable of that rate.

1. Open a command terminal at 921,600 baud via an RS-422 serial link.  
By default, the IMU will output 0.5 Hz binary messages which will help confirm you are connected properly.
2. Issue the following two commands in sequence to enter configuration mode and change the baud rate.
 

```
=CONFIG,1
=MSYNC,EXT
=BAUD,460800
```
3. Upon completion of these commands, power cycle the IMU to boot up in the new baud rate.
4. Confirm the change by connecting to the IMU at 460,800 baud and verifying the incoming messages.

The new baud rate configuration is saved to the IMU NVM automatically so the process is complete and the IMU is ready for use with an OEM7 receiver.

### Use an OEM6 Receiver Command

OEM6 firmware as of version OEM060631RN0000 (Dec 2016) includes the **IMUCONFIGURATION** command that internally configures the KVH1750 IMU for SPAN communication. Three sets of configuration options are available, two of which allow changing the baud rate of the IMU to either 921,600 or 460,800. This provides customers upgrading to OEM7 an easy method to modify the baud rate. To change the IMU to 460800 baud, use the following procedure:

1. Connect the KVH-1750 IMU to an RS-422 capable OEM6 receiver communication port.
2. Issue the following command.

```
CONNECTIMU COM# IMU_KVH_1750
```

- Issue the following command.

```
IMUCONFIGURATION IMU_KVH_1750 2
```

The **IMUCONFIGURATION** command can be used to configure a KVH17xx IMU depending on the value of the Option field.

```
IMUCONFIGURATION IMUType [Option]
```

IMU Type	Option	Configuration Details
IMU_KVH_1750	0	Configure KVH options for NovAtel communication.
	1	Change KVH baud rate to 921,600
	2	Change KVH baud rate to 460,800

### 2.1.6 Connect Power



If you are using a MEMS OEM IMU (ADIS-16488, HG1900, HG1930, STIM300) and a MIC, see *MIC Installation* on page 57 for information about connecting and powering the MIC and IMU.



If you are using an OEM IMU (ISA-100C, HG1900, LN200 or  $\mu$ IMU) and a UIC, see *UIC Installation* on page 68 for information about connecting and powering the UIC and IMU.

#### Receiver Power

For information about connecting power to an OEM7 receiver card, see the [OEM7 Installation and Operation User Manual](#).

For information about connecting power to a PwrPak7, see the [PwrPak7 Installation and Operation User Manual](#).

#### IMU Power

In addition to the receiver power supply, a power supply is needed for the IMU. See *Table 12: IMU Power Supply* below for the voltage requirements for each IMU. The same power supply can be used for the receiver and the IMU, if the power supply meets the power requirements of both devices.

**Table 12: IMU Power Supply**

IMU	Power Requirement
IMU-CPT	+9 to +18 VDC
IMU-FSAS	+10 to +34 VDC
IMU-HG1900	+10 to +34 VDC
IMU-IGM	+10 to +30 VDC
IMU-ISA-100C	+10 to +34 VDC
IMU-KVH1750	+9 to +36 VDC

IMU	Power Requirement
IMU-ENC-LN200	+10 to +34 VDC
IMU- $\mu$ IMU	+10 to +34 VDC
UIMU-HG1700 (AG58 or AG62)	+12 to +28 VDC
UIMU-LN200	+12 to +28 VDC
OEM-IMU-ADIS-16488 (direct connection)	+3.3 VDC
OEM-IMU-EG320N (direct connection)	+3.3 VDC
OEM-IMU-EG370N (direct connection)	+3.3 VDC
OEM-IMU-HG4930 (direct connection)	+5.0 VDC
OEM-IMU-STIM300 (direct connection)	+5.0 VDC

For most IMUs, connect the power leads on the IMU interface cable to the IMU power supply.

For an IMU in the IMU Enclosure (IMU-HG1900, IMU-ISA-100C, IMU-ENC-LN200 or IMU- $\mu$ IMU-IC), connect the IMU Power Cable (NovAtel part # 60723136) from the IMU to the IMU power supply.



The IMU Power Cable has four power leads, two positive (VIN+) and two negative (VIN-). Typically, all four wires are connected to the power supply. However, the IMU Enclosure can be powered from a single pair (VIN+ and VIN-). This is beneficial in systems with a backup power supply as one pair can be connected to the main power supply and the second pair can be connected to the backup power supply.

Details about the IMU ports and cables can be found in *IMU Technical Specifications* on page 135.



## 2.2 MIC Installation

For an IMU that cannot communicate directly to a NovAtel OEM7 receiver (e.g. SDLC/HDLC), an interface card is required for communication. The MEMS Interface Card (MIC) provides this communication between an OEM7 receiver card and the IMU.



A MIC is required to connect the following IMUs with an OEM7 receiver: HG-1700, HG-1900 and HG-1930. For other IMUs that require an interface card (e.g. ISA100C, LN200 or  $\mu$ IMU), the Universal Interface Controller (UIC) is required to handle the additional power requirements. See *UIC Installation* on page 68.

There are two MIC configurations: stack up and standalone. In a stack up configuration, the MIC card is mounted on an OEM719 receiver. In a standalone configuration, the MIC is mounted separately from the receiver.



The MIC supports all OEM7 receiver cards for communications. The OEM719 is the only OEM7 receiver card that can be directly integrated and powered by the MIC.

### 2.2.1 Install a MIC in a Stack Up Configuration

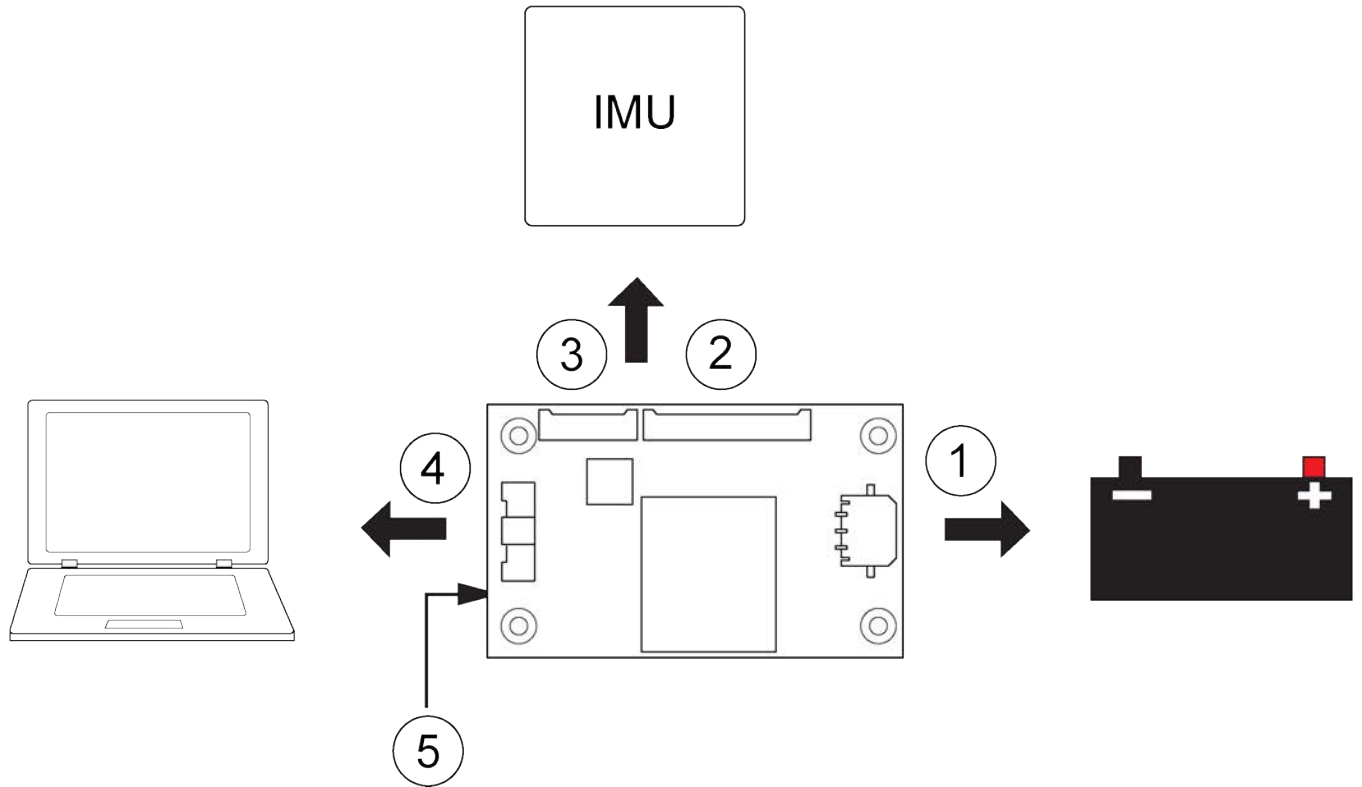
In a stack up configuration, the MIC is connected to an OEM719 receiver using the 20-pin header on the OEM719. Power and communications connections to the receiver are made through the MIC.



**Important!** Assemble in accordance with applicable industry standards. Ensure all Electrostatic Discharge (ESD) measures are in place, in particular, use a ground strap before exposing or handling any electronic items, including the MIC, receiver and IMU. Take care to prevent damaging or marring painted surfaces, O-rings, sealing surfaces and the IMU.

For more information about ESD practices, see the [OEM7 Installation and Operation User Manual](#).

**Figure 6: Basic Set Up – MIC in Stack Up Configuration**



Ref	Connector	Part Number	Mating Connector	Description
1	P101	43650-0313 (Molex)	43645-0300 (Molex)	Connects to the MIC power supply. This connection provides power to the MIC and the OEM719 receiver. (user supplied cable)
2	P601	53780-2070 (Molex)	51146-2000 (Molex)	Connects to HG1700, HG1900, HG1930 and STIM300 IMUs. (NovAtel supplied cable kit)
3	P701	53780-1070 (Molex)	51146-1000 (Molex)	Connects to ADIS-16488 IMUs. (NovAtel supplied cable kit)
4	P301	501571-3007 (Molex)	501189-3010 (Molex)	Connects the MIC and OEM719 communication signals to the user system. (user supplied cable)
5	J301	ASP-163577-01 (Samtec)	N/A	Connects to the main connector (P1701) on an OEM719 receiver. J301 is on the bottom of the MIC card



For information about the MIC connectors and pin-outs, see *MIC Connectors* on page 263.



For information about the OEM7 receiver card connectors and pinouts, refer to the [OEM7 Installation and Operation User Manual](#).

Use the following steps to install the OEM719 receiver and MIC:

1. Mount the components of the SPAN system. See *Mount the SPAN System Components* below.
2. Connect the IMU to the MIC. See *Connect the IMU to the MIC* on page 64.
3. Connect power to the MIC. See *Connect Power to the MIC* on page 62.
4. Connect the input and output signals to the MIC. See *Connect the Input and Output Signals* on page 62.

### Mount the SPAN System Components

1. Mount the antenna. See *Mounting the GNSS Antenna* on page 35.
2. Use the standoffs supplied with the MIC card to secure the OEM719 to its mounting location. See *Figure 7: Mount the MIC on the OEM719* on the next page. See the [OEM7 Installation and Operation User Manual](#) for information about installing an OEM7 receiver.



The part number for the recommended standoffs is RAF-M21073005AL7 (Irwin Industrial).

If alternate standoffs are selected, use equivalent parts with a minimum height of 12 mm.



Ensure all standoffs are properly installed and the mounting location is flat.

The amount of board deflection (bow and twist) must not exceed 0.75%. For example, on the MIC which is 75 mm long and 46 mm wide, the deflection along the length must not exceed 0.56 mm and the deflection along the width must not exceed 0.34 mm.



Ensure the MIC is mounted close enough to the IMU so the interface cable can reach both devices.

3. Connect the antenna cable to the antenna jack on the OEM719.

The antenna cable must have a right angle MCX connector on the end that connects to the OEM719.

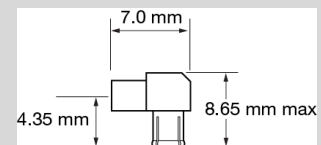


**Warning!** Do not apply power to the cards until the antenna cable is attached.



The part number for the recommended MCX connector is M1051-110 (ShinA Telecom). If an alternate part is used, it should meet the dimensions shown in the diagram.

The space between the OEM719 and the MIC is limited. The height of the MCX connector must not exceed 8.65 mm.



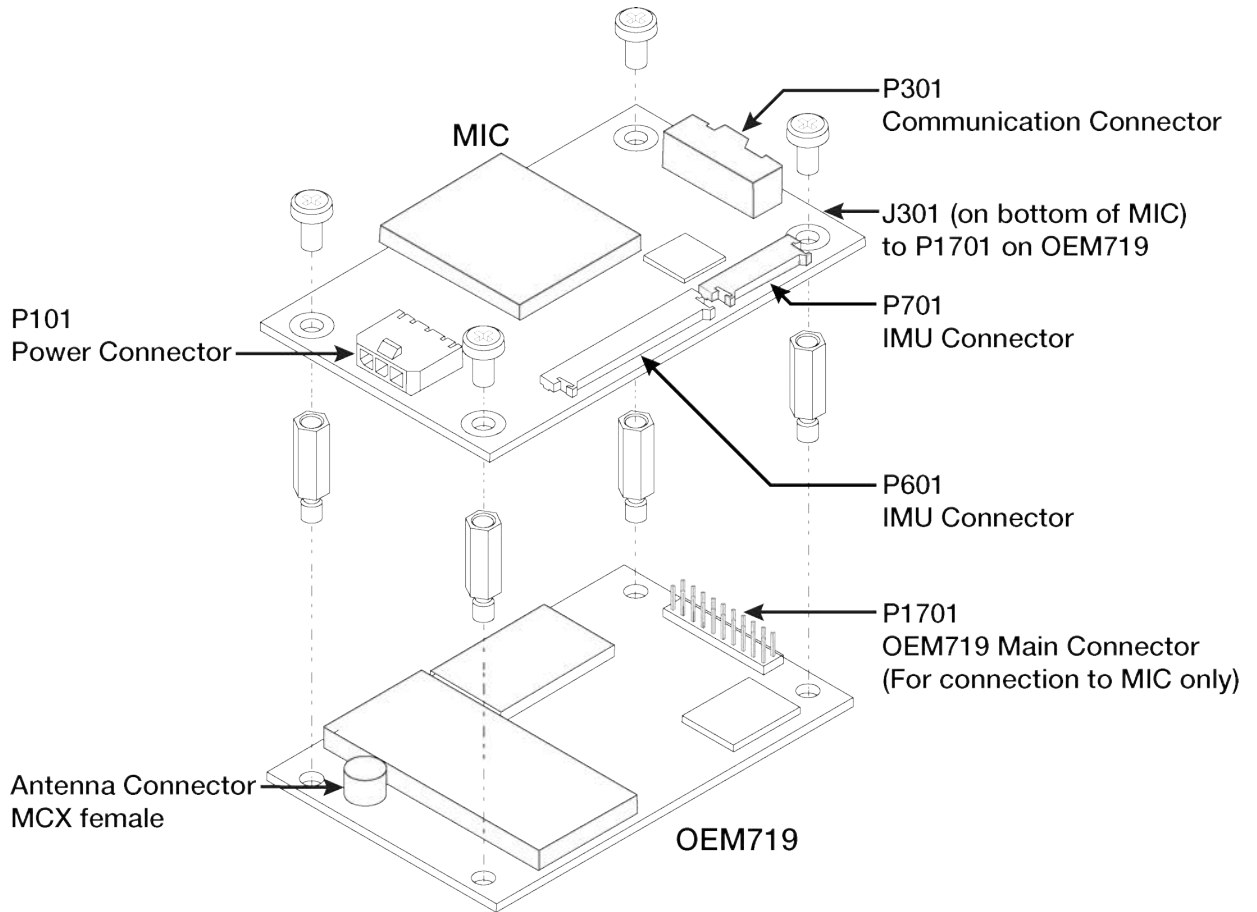
4. Align the mating connector (J301) on the MIC with the 20-pin header (P1701) on the OEM719.

Make sure all of the pins on the header are aligned with the holes in the mating connector.

Press down on the MIC to seat the connector on the header.

- Use the four screws supplied with MIC to secure the MIC card to the OEM719.

**Figure 7: Mount the MIC on the OEM719**



### Connect the IMU to the MIC

- Attach the IMU mounting Printed Circuit Board (PCB) to the IMU. Ensure all the pins on the header are aligned with the holes on the mating connector.

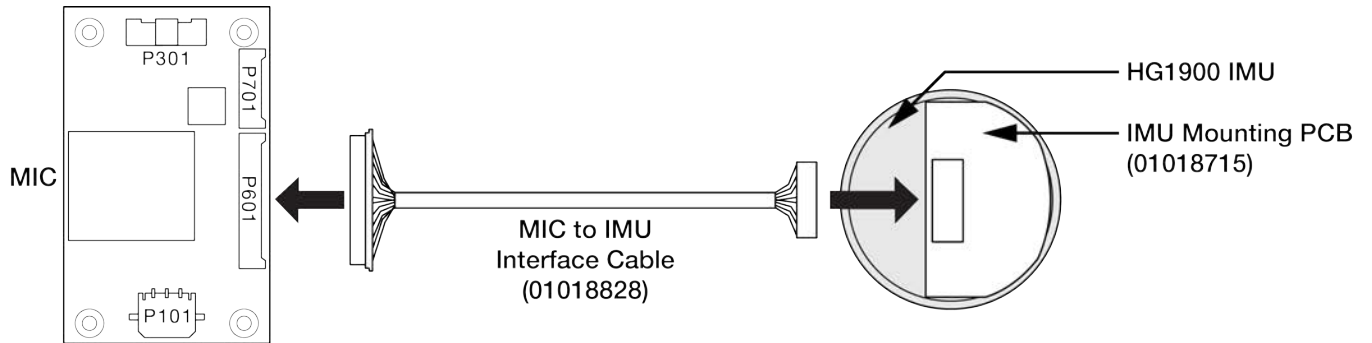


An IMU mounting PCB is not used with the STIM300 IMU.

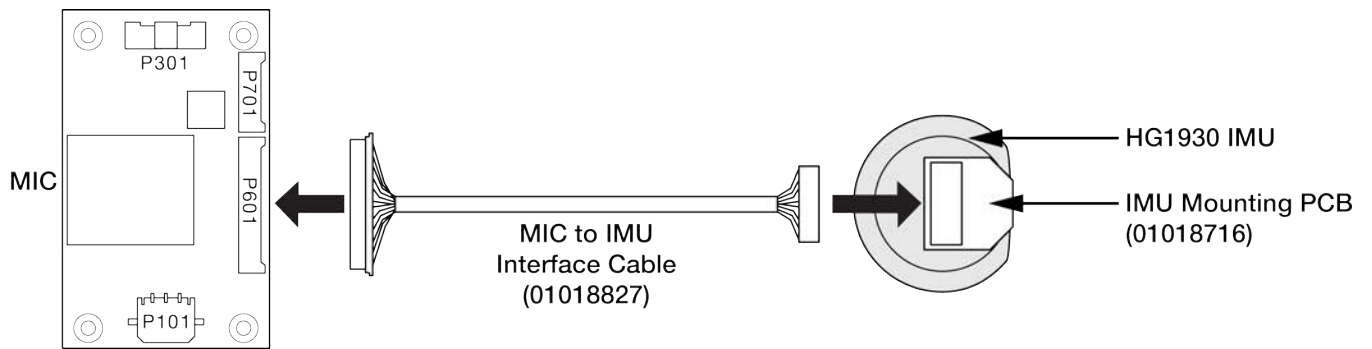
- Connect the IMU-to-MIC interface cable to the IMU.
- Connect the IMU-to-MIC interface cable to the IMU connector on the MIC.
  - Use the 10 pin locking connector (P701) for the ADIS-16488 IMUs. See *Figure 10: Connect the ADIS-16488 IMU to the MIC (OEM Cable Kit: 01019007)* on the next page.
  - Use the 20 pin locking connector (P601) for the HG1700, HG1900, HG1930 or STIM300 IMU. See *Figure 8: Connect the HG1900 IMU to the MIC (OEM Cable Kit: 01018871)* on the next page, *Fig-*


ure 9: Connect the HG1930 IMU to the MIC (OEM Cable Kit: 01018869) on the next page or Figure 11: Connect the STIM300 IMU to the MIC (OEM Cable Kit: 01019174) on the next page.

**Figure 8: Connect the HG1900 IMU to the MIC (OEM Cable Kit: 01018871)**

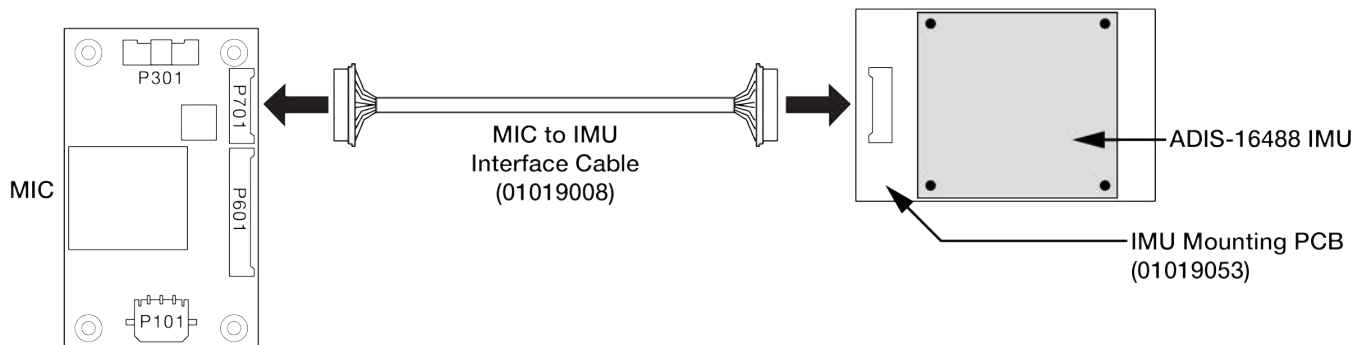


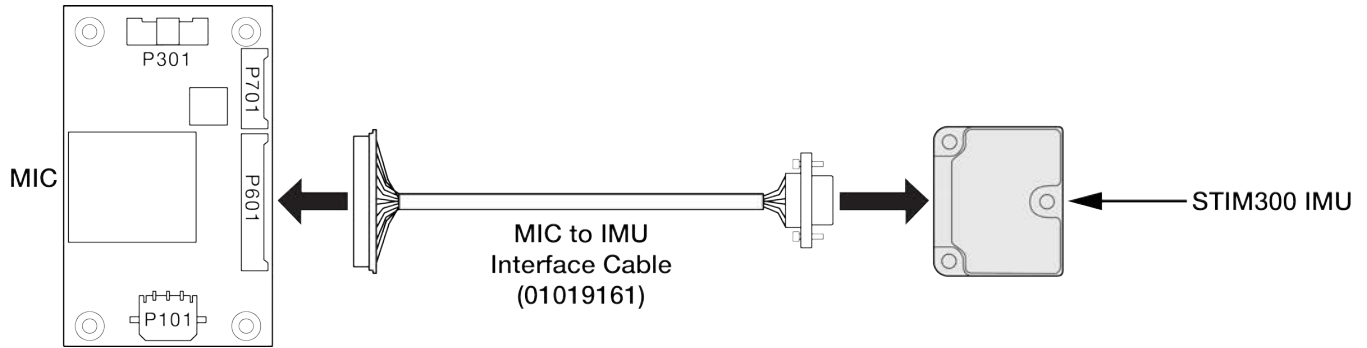
**Figure 9: Connect the HG1930 IMU to the MIC (OEM Cable Kit: 01018869)**



 The ADIS-16488 and STIM-300 are capable of a direct connection with OEM7 receivers, when a proper connection is available (ADIS-16488 = SPI, STIM300 = serial RS-422). If using the MIC connection is necessary, the following diagrams detail the cable connection parts between the MIC and IMU.

**Figure 10: Connect the ADIS-16488 IMU to the MIC (OEM Cable Kit: 01019007)**



**Figure 11: Connect the STIM300 IMU to the MIC (OEM Cable Kit: 01019174)**

### Connect Power to the MIC

Connect a +10 to +30 VDC power supply to the power connector (P101) on the MIC. See *MIC Connectors* on page 263 for pinout information for the power connector.



This connection provides power to the MIC, the OEM719 and the IMU.

### Connect the Input and Output Signals

All of the communication connections to the MIC and the OEM719 receiver are available on the communications connector (P601) on the MIC. These connections include:

- MIC serial port
- OEM719 serial port (COM2)
- USB port
- Event1 trigger input
- Event2 trigger input
- 1 PPS (Pulse Per Second) output
- VARF (Variable Frequency) output
- Reset input
- Position Valid output

See *MIC Connectors* on page 263 for the pinouts of the communications connector.



All signal I/O with the exception of the USB port are at LVCMOS levels. To connect the MIC to devices that use other signals levels, such as a computer with an RS-232 serial port, an interface circuit that converts LVCMOS to the other signal level must be used.



Use a twisted pair for the USB port connection and keep the wires as short as possible.

### 2.2.2 Install a MIC in a Standalone Configuration

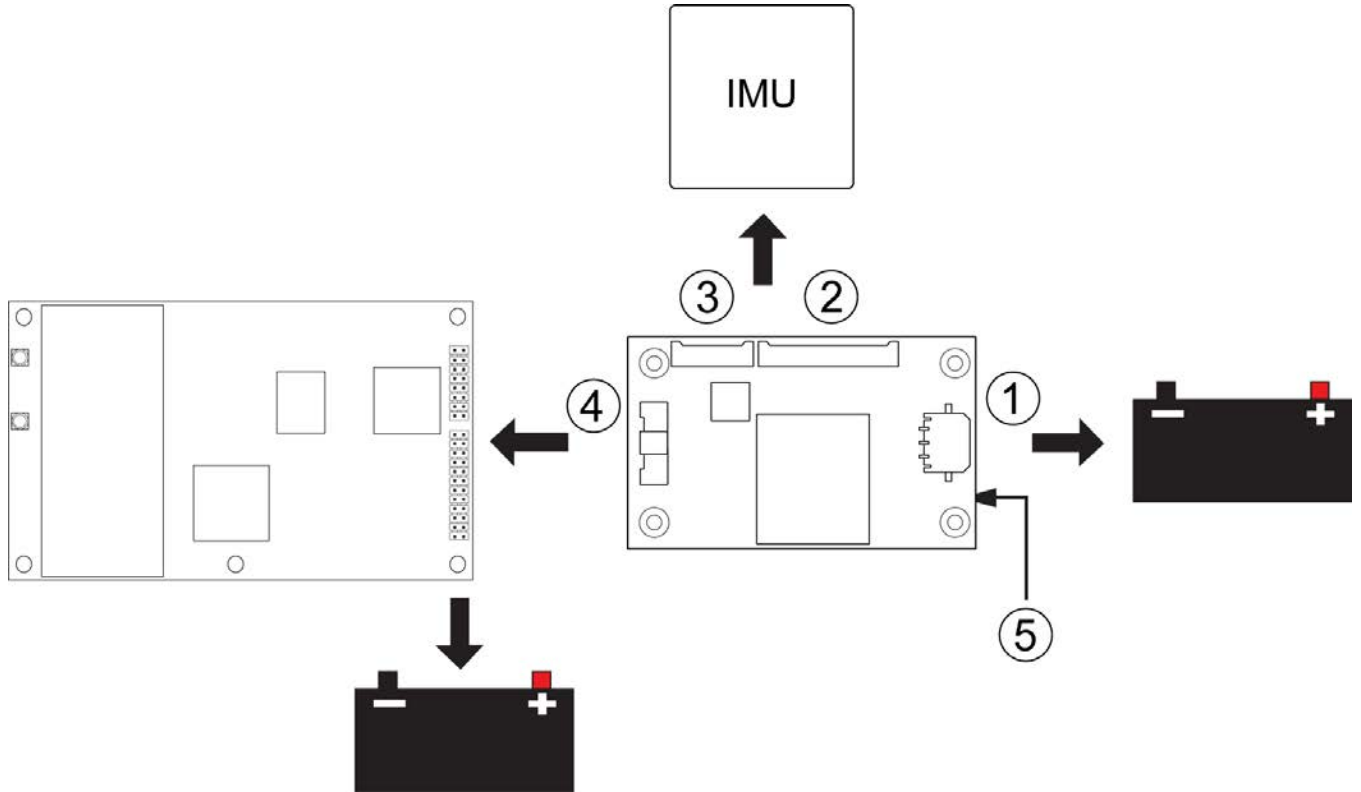
In a standalone configuration, the MIC is mounted separately from the OEM7 receiver.



**Important!** Assemble in accordance with applicable industry standards. Ensure all Electrostatic Discharge (ESD) measures are in place, in particular, use a ground strap before exposing or handling any electronic items, including the MIC, receiver and IMU. Take care to prevent damaging or marring painted surfaces, O-rings, sealing surfaces and the IMU.

For more information about ESD practices, see the [OEM7 Installation and Operation User Manual](#).

**Figure 12: Basic MIC Set Up**



Ref	Connector	Part Number	Mating Connector	Description
1	P101	43650-0313 (Molex)	43645-0300 (Molex)	Connects to the MIC power supply. (user supplied cable)
2	P601	53780-2070 (Molex)	51146-2000 (Molex)	Connects to HG1700, HG1900, HG1930 and STIM300 IMUs. (NovAtel supplied cable)
3	P701	53780-1070 (Molex)	51146-1000 (Molex)	Connects to ADIS-16488 IMUs. (NovAtel supplied cable)
4	P301	501571-3007 (Molex)	501189-3010 (Molex)	Connects the MIC serial port to the OEM7 receiver. (user supplied cable)
5	J301	ASP-163577-01 (Samtec)	N/A	This connector is not used.



For information about the MIC connectors and pin-outs, see *MIC Connectors* on page 263.



For information about the OEM7 receiver card connectors and pinouts, refer to the [OEM7 Installation and Operation User Manual](#).



#### OEM729 Recommendations

- Use COM1 for connection to a computer. COM1 uses RS-232 levels and can be connected to a computer without additional interface circuitry.
- Use COM2 for connection to the MIC serial port. Both the MIC serial port and COM2 use LVCMOS levels and can be connected without additional interface circuitry.

Use the following steps to install the OEM7 receiver and MIC:

1. Mount the components of the SPAN system. See *Mount the SPAN System Components* below.
2. Connect the IMU to the MIC. See *Connect the IMU to the MIC* below.
3. Connect the MIC to the OEM7 receiver. See *Connect the MIC to a Receiver* on page 66.
4. Connect power to the MIC and OEM7 receiver. See *Connect Power to the MIC and OEM7 Receiver* on page 67.

### Mount the SPAN System Components

1. Mount the antenna. See *Mounting the GNSS Antenna* on page 35.
2. Mount the OEM7 receiver. See the [OEM7 Installation and Operation User Manual](#) for information about installing an OEM7 receiver.
3. Install the MIC in a secure enclosure to reduce environmental exposure and RF interference. If there is sufficient space, the MIC can reside in the same enclosure as the receiver.

Use the screws supplied with the MIC card to secure the MIC to its mounting location. See *MIC Mechanical Drawings* on page 260 for the MIC dimensions.



Ensure the MIC is mounted close enough to the IMU so the interface cable can reach both devices.



Ensure all standoffs are properly installed and the mounting location is flat. The amount of board deflection (bow and twist) must not exceed 0.75%. For example, on the MIC which is 75 mm long and 46 mm wide, the deflection along the length must not exceed 0.56 mm and the deflection along the width must not exceed 0.34 mm.

4. Mount the IMU. See *Mount the IMU* on page 36.

### Connect the IMU to the MIC

1. Attach the IMU mounting Printed Circuit Board (PCB) to the IMU. Ensure all the pins on the header are aligned with the holes on the mating connector.

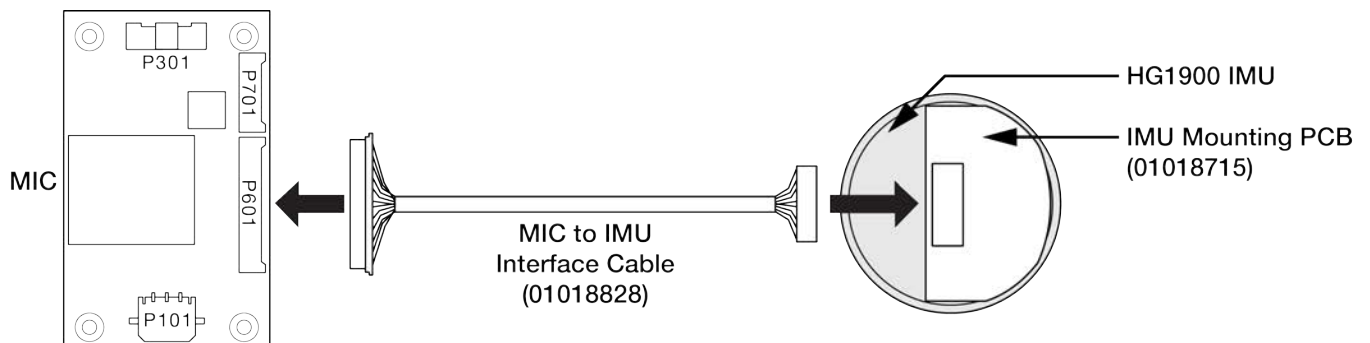




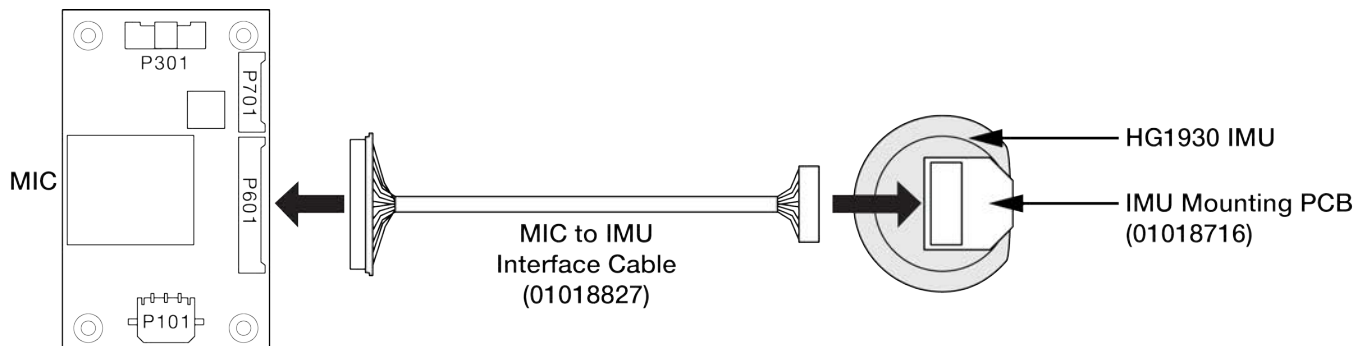
An IMU mounting PCB is not used with the STIM300 IMU.

2. Connect the IMU-to-MIC interface cable to the IMU.
3. Connect the IMU-to-MIC interface cable to the IMU connector on the MIC.
  - Use the 10 pin locking connector (P701) for the ADIS-16488 IMUs.  
See *Figure 15: Connect the ADIS-16488 IMU to the MIC (OEM Cable Kit: 01019007)* on the next page.
  - Use the 20 pin locking connector (P601) for the HG1700, HG1900, HG1930 or STIM300 IMU.  
See *Figure 13: Connect the HG1900 IMU to the MIC (OEM Cable Kit: 01018871)* below, *Figure 14: Connect the HG1930 IMU to the MIC (OEM Cable Kit: 01018869)* below or *Figure 16: Connect the STIM300 IMU to the MIC (OEM Cable Kit: 01019174)* on the next page.

**Figure 13: Connect the HG1900 IMU to the MIC (OEM Cable Kit: 01018871)**

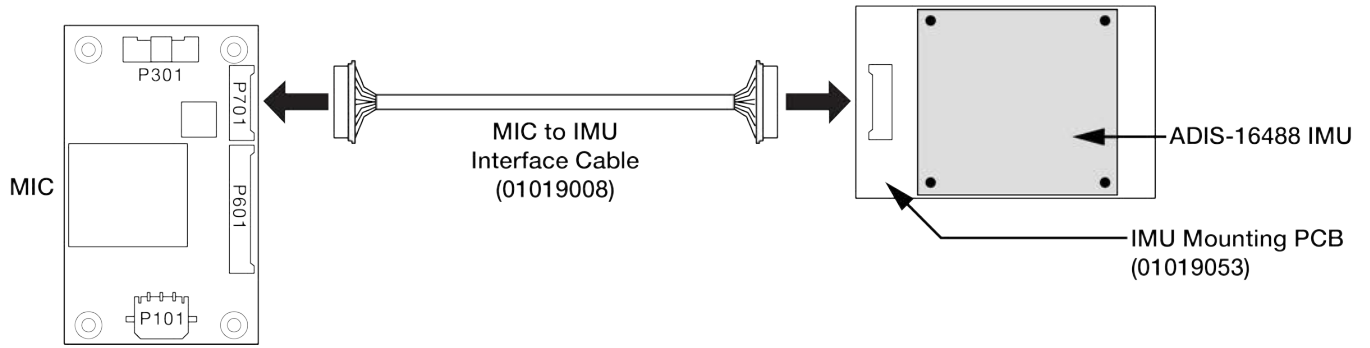


**Figure 14: Connect the HG1930 IMU to the MIC (OEM Cable Kit: 01018869)**

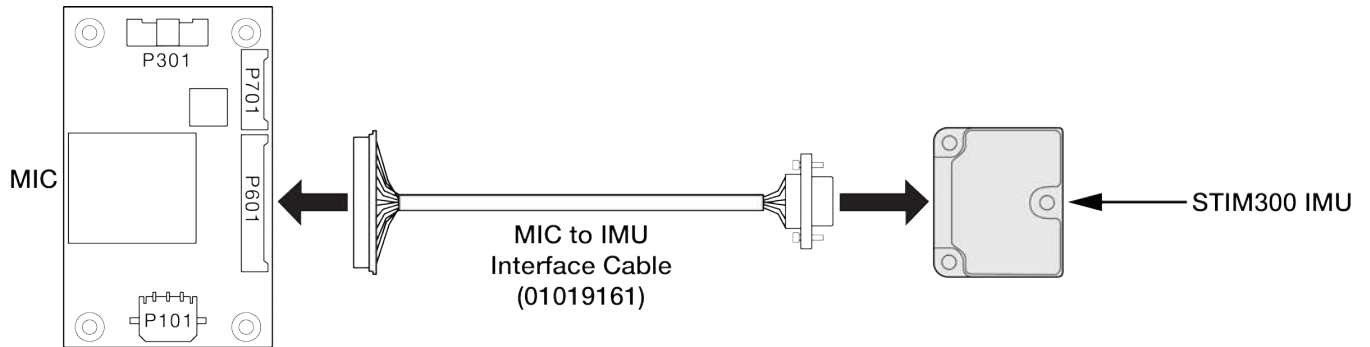


The ADIS-16488 and STIM-300 are capable of a direct connection with OEM7 receivers, when a proper connection is available (ADIS-16488 = SPI, STIM300 = serial RS-422). If using the MIC connection is necessary, the following diagrams detail the cable connection parts between the MIC and IMU.

**Figure 15: Connect the ADIS-16488 IMU to the MIC (OEM Cable Kit: 01019007)**




**Figure 16: Connect the STIM300 IMU to the MIC (OEM Cable Kit: 01019174)**



**Connect the MIC to a Receiver**

1. Using a customer supplied wiring harness, connect the MIC serial port to a serial port on the OEM7 receiver. The MIC serial port is available on the communications connector (P301) of the MIC.

See *MIC Connectors* on page 263 for the pinouts of the communications connector. See the [OEM7 Installation and Operation User Manual](#) for information about connecting a serial port to the receiver.

 All signal I/O on the MIC, with the exception of the USB port, are at LVCMOS levels. To connect the MIC to devices that use other signals levels, such as a computer with an RS-232 serial port, an interface circuit that converts LVCMOS to the other signal level must be used.

**Table 13: COM Port Recommendations**

<b>OEM719</b>	
<b>OEM7600</b>	All of the COM ports on these receivers use LVCMOS levels and are signal level compatible with the MIC serial port.
<b>OEM7700</b>	
<b>OEM7720</b>	
<b>OEM729</b>	Use COM2 or COM3 of the OEM729 receiver to connect the MIC serial port. These COM ports use LVCMOS levels and are signal level compatible with the MIC serial port. COM1 on the OEM729 receiver can use RS-232 levels (default) or RS-422 levels and is not signal level compatible with the MIC serial port.



For information about the OEM7 receiver card connectors and pinouts, refer to the [OEM7 Installation and Operation User Manual](#).

2. Connect a computer (for monitoring and configuration) to the OEM7 receiver. Refer to the [OEM7 Installation and Operation User Manual](#) for information about connecting data communications equipment to an OEM7 receiver.

### Connect Power to the MIC and OEM7 Receiver



A separate power supply is required for the OEM7 receiver. For information about the power supply requirements, refer to the Technical Specifications appendix for the receiver card in the [OEM7 Installation and Operation User Manual](#).

1. Using a customer supplied wiring harness, connect a +10 to +30 VDC power supply to the power connector (P101) on the MIC. See *MIC Connectors* on page 263 for pinout information for the power connector.
2. Using a customer supplied wiring harness, connect power to the OEM7 receiver. See the [OEM7 Installation and Operation User Manual](#) for information about connecting power to the receiver.

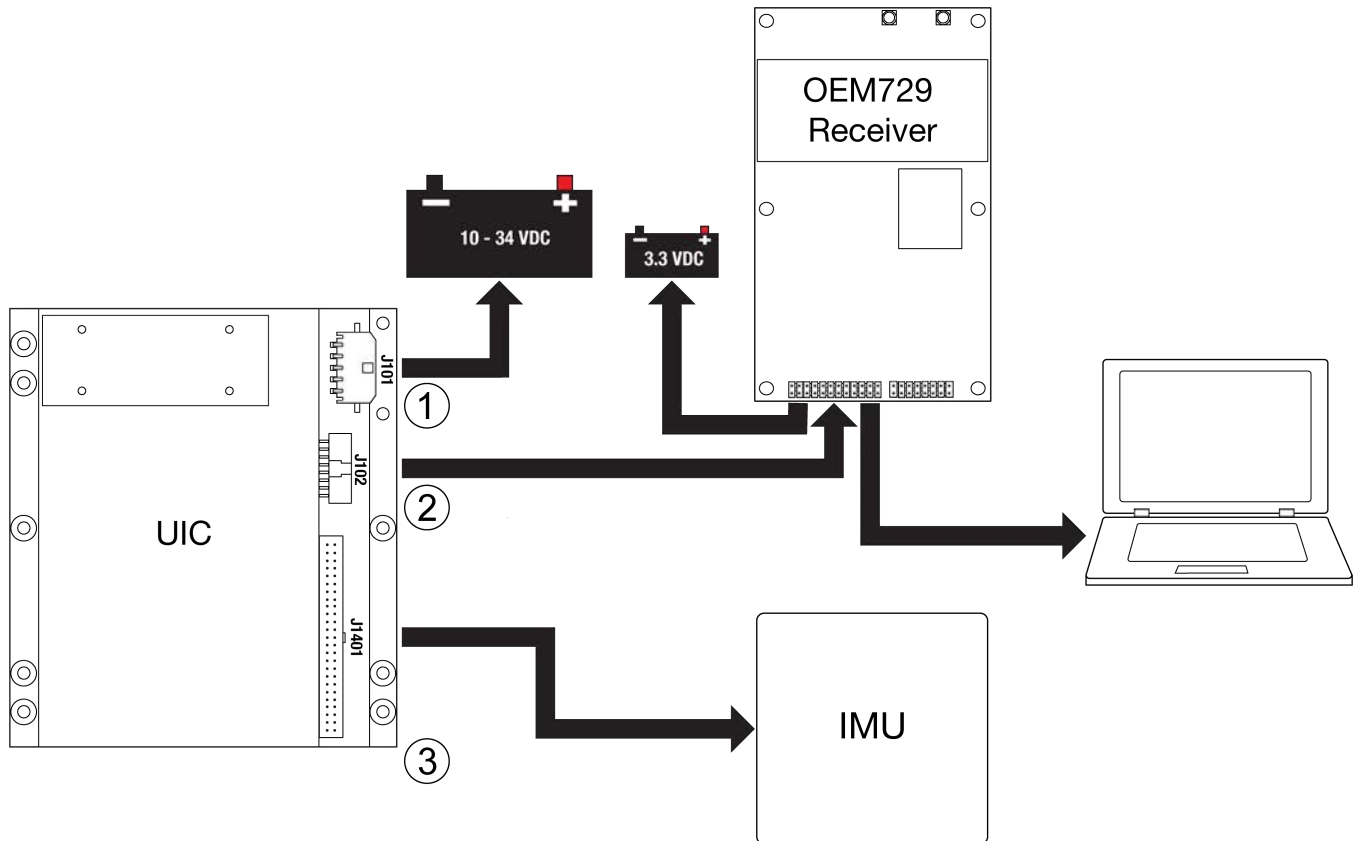
## 2.3 UIC Installation

For an IMU that cannot communicate directly to a NovAtel OEM7 receiver (e.g. SDLC/HDLC), an interface card is required for communication. The Universal Interface Controller (UIC) provides this communication between an OEM7 receiver card and the IMU, specifically an IMU that has higher power requirements.



Use a UIC to connect the following IMUs with an OEM7 receiver: ISA-100C, LN200(C) and Litef- $\mu$ IMU. For other IMUs that require an interface card and have lower power requirements (e.g. HG-1700, HG-1900 and HG-1930) a MEMS Interface Card (MIC) can be used. See *MIC Installation* on page 57.

Figure 17: Basic UIC Installation



Ref	Connector	Part Number	Mating Connector	Description
1	J101	43650-0513 (Molex)	43645-0500 (Molex)	Connects to the UIC power supply (user supplied cable)
2	J102	98464-G61-16LF (FCI)	90311-016LF (FCI)	Connects the UIC serial port to the OEM7 receiver (user supplied cable)
3	J1401	LTMM-125-02-L-D (Samtec)	SQT-125-01-L-D (Samtec)	Connects to the IMU (NovAtel supplied cable)



For information about the UIC connectors and pinouts, see *UIC Connectors* on page 276.



For information about the OEM7 receiver card connectors and pinouts, refer to the [OEM7 Installation and Operation User Manual](#).



**Important!** Assemble in accordance with applicable industry standards. Ensure all Electrostatic Discharge (ESD) measures are in place, in particular, use a ground strap before exposing or handling any electronic items, including the UIC, receiver and IMU. Take care to prevent damaging or marring painted surfaces, O-rings, sealing surfaces and the IMU.

For more information about ESD practices, see the [OEM7 Installation and Operation User Manual](#).

Use the following steps to install the OEM7 receiver and UIC:

1. Mount the components of the SPAN system. See *Mount the SPAN System Components* below.
2. Connect the IMU to the UIC. See *Connect the IMU to the UIC* on the next page.
3. Connect the UIC to the OEM7 receiver. See *Connect the UIC to a receiver* on the next page.
4. Connect power to the UIC and OEM7 receiver. See *Connect Power to the UIC and OEM7 Receiver* on page 71.

### 2.3.1 Mount the SPAN System Components

1. Mount the antenna. See *Mounting the GNSS Antenna* on page 35.
2. Mount OEM7 receiver. See the [OEM7 Installation and Operation User Manual](#) for information about installing an OEM7 receiver.
3. Mount the IMU. See *Mount the IMU* on page 36.
4. Install the UIC in a secure enclosure to reduce environmental exposure and RF interference. If there is sufficient space, the UIC can reside in the same enclosure as the receiver.


Use M3 pan head stainless steel screws to secure the UIC to its mounting location. See *UIC Mechanical Drawings* on page 273 for the UIC dimensions.



Ensure the UIC is mounted close enough to the IMU so the interface cable can reach both devices. For the length of the interface cable, refer to the specifications for the IMU in *IMU Technical Specifications* on page 135.



Ensure the mounting location provides at least 5 mm of clearance below the board to allow for components on the bottom of the UIC.


 Ensure all standoff are properly installed and the mounting location is flat. The amount of board deflection (bow and twist) must not exceed 0.75%. For example, on the UIC which is 100 mm long and 113 mm wide, the deflection along the length must not exceed 0.75 mm and the deflection along the width must not exceed 0.85 mm.

### 2.3.2 Connect the IMU to the UIC

1. If using an ISA-100C, attach the screw kit to the *IMU to UIC Interface Cable*.
2. Connect the *IMU to UIC Interface Cable* supplied with the UIC to the IMU. For IMU cables with screws, secure the cable to the IMU using the screws.
3. Connect the *IMU to UIC Interface Cable* to the IMU connector (J1401) on the UIC.


### 2.3.3 Connect the UIC to a receiver

1. Using a customer supplied wiring harness, connect the UIC serial port to a serial port on the OEM7 receiver. See *UIC Connectors* on page 276 for pinout information for the communications connector (J102).

 The serial port on the UIC uses RS-422 levels. To connect the UIC to devices that use other signals levels, such as an LVCMOS COM port on the OEM7 receiver, an interface circuit that converts to and from RS-422 must be used.

**Table 14: COM Port Recommendations**

<p><b>OEM719</b> <b>OEM7600</b> <b>OEM7700</b> <b>OEM7720</b></p>	<p>All of the COM ports on these receivers use LVCMOS levels. An interface circuit that converts to and from RS-422 levels is required for the port connected to the UIC.</p>
<p><b>OEM729</b></p>	<p>COM1 on the OEM729 receiver can use RS-232 (default) or RS-422 levels. To use COM1 for connection to the UIC, configure the COM1 port to use RS-422 levels. Refer to the <a href="#">OEM7 Installation and Operation User Manual</a> for information about changing COM1 to RS-422 levels.</p> <p>COM2 and COM3 on the OEM729 receiver use LVCMOS levels. To use COM2 or COM3 for connection to the UIC serial port, an interface circuit that converts to and from RS-422 levels is required.</p>

 For information about the OEM7 receiver card connectors and pinouts, refer to the [OEM7 Installation and Operation User Manual](#).

2. Connect a computer (for monitoring and configuration) to the OEM7 receiver. Refer to the [OEM7 Installation and Operation User Manual](#) for information about connecting data communications equipment to an OEM7 receiver.

### 2.3.4 Connect Power to the UIC and OEM7 Receiver



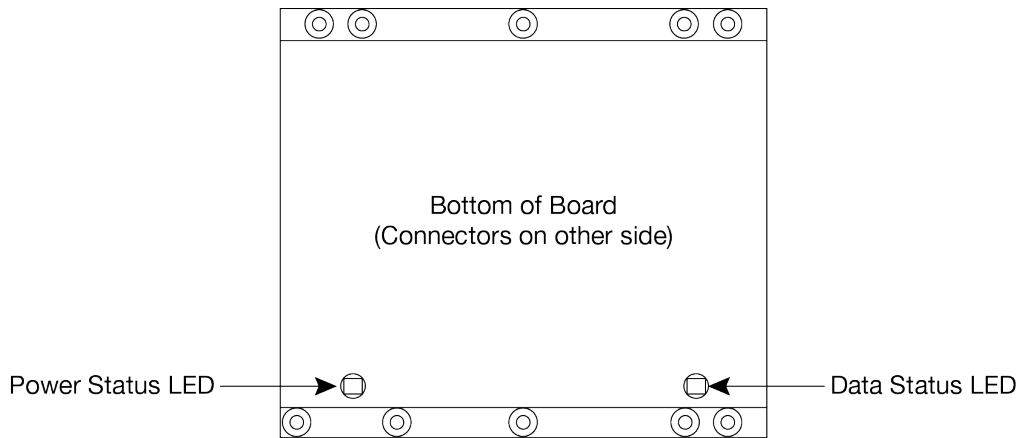
A separate power supply is required for the OEM7 receiver. For information about the power supply requirements, refer to the Technical Specifications appendix for the receiver card in the [OEM7 Installation and Operation User Manual](#).

1. Using a customer supplied wiring harness, connect a +10 to +34 VDC power supply to the power connector (J101) on the UIC.  
See *UIC Connectors* on page 276 for pinout information for the power connector.
2. Using a customer supplied wiring harness, connect power to the OEM7 receiver. See the [OEM7 Installation and Operation User Manual](#) for information about connecting power to the receiver.

### 2.3.5 UIC Status LEDs

The LEDs on the UIC provide basic status information.

**Figure 18: UIC Status LEDs**



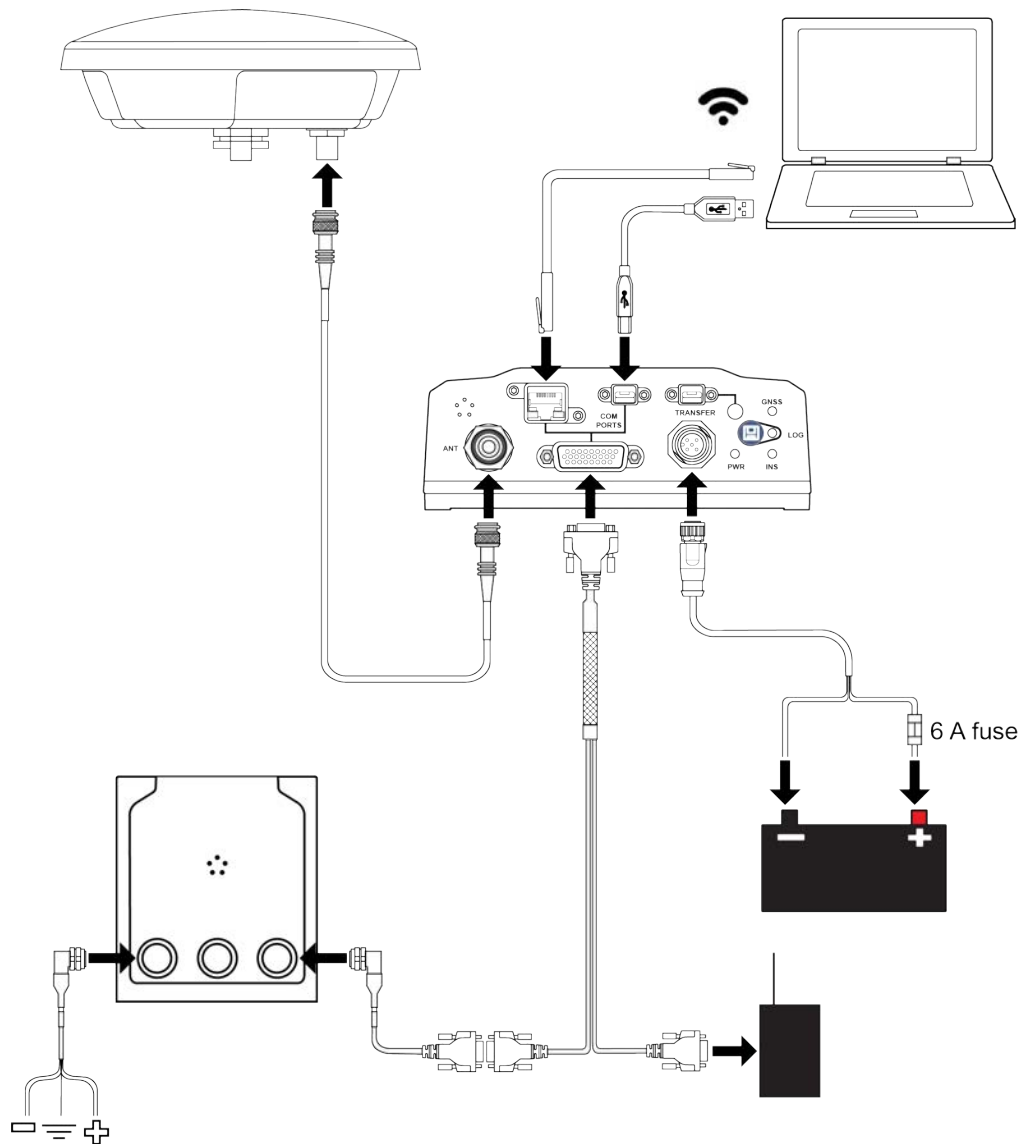
**Table 15: UIC Status LEDs**

LED	Off	On (Red)	On (Green)	Flash Slow (Yellow, 1 Hz)	Flash Fast (Yellow, 3 Hz)
Power	No power to UIC.	An error occurred during boot up or initialization.	UIC is powered on with no errors detected during boot up or initialization.	Boot up and IMU initialization.	N/A
Data	No communication between UIC and GNSS receiver.	N/A	UIC is transmitting and receiving data without errors.	UIC is receiving data from the receiver, but not transmitting data.	UIC is transmitting data to the receiver, but not receiving data.

## 2.4 PwrPak7 Installation

The following diagram shows a typical SPAN installation using a PwrPak7 and an IMU in an enclosure.

**Figure 19: Typical Installation of a SPAN System with a PwrPak7**



Complete the following steps to set up your NovAtel SPAN system.

1. Mount the GNSS antenna.

See *Mounting the GNSS Antenna* on page 35 for details.

2. Mount the IMU.

See *Mount the IMU* on page 36 for details.

3. Mount the PwrPak7.

See the [PwrPak7 Installation and Operation User Manual](#) for information about mounting a PwrPak7.



4. Connect the antenna cable from the GNSS antenna to the ANT port on the PwrPak7.  
For PwrPak7D, connect the primary GNSS antenna to the ANT 1 port and the secondary GNSS antenna to the ANT 2 port.
5. Connect the IMU to the OEM7 receiver.  
See *Connect the IMU to the PwrPak7* below for details.
6. Connect the I/O strobe signals (optional).  
See the [PwrPak7 Installation and Operation User Manual](#) for information about connecting I/O signals to a PwrPak7.
7. Connect power to the IMU and receiver.  
See *Connect Power* on page 55 for details.
8. Connect a data communication device, such a computer, to the receiver. A data communication device is used to configure and monitor the receiver.  
See the [PwrPak7 Installation and Operation User Manual](#) for information about connecting a data communication device to a PwrPak7.

### 2.4.1 Connect the IMU to the PwrPak7

Connect the IMU to the COM1 or COM2 serial port on the PwrPak7. Both of these serial ports are available on the HD26 COM PORTS connector on the PwrPak7.



#### IMU-CPT, IMU-KVH1750, IMU-FSAS and IMU-STIM300D

These IMUs require an additional output or input from the HD26 COM PORTS connector on the PwrPak7 to synchronize the IMU and receiver. See *Table 16: Additional IMU to PwrPak7 Connections* on the next page.



If using a KVH1750 IMU, the baud rate of the IMU must be changed to 460,800 bps. For information about changing the IMU baud rate, see *KVH1750 Baud Rate Conversion* on page 54.

### NovAtel IMU Interface Cables

An interface cable is available from NovAtel for each IMU supported by OEM7 receivers. The interface cables provide access to the IMU power and communication signals. For information about these cables, refer to the applicable IMU in the *IMU Technical Specifications* on page 135.

### PwrPak7 Cables

The following communication cable is available from NovAtel for connecting an IMU to the PwrPak7.

- PwrPak7 IMU Cable (01019767)

This cable connects the PwrPak7 to an IMU in an IMU Enclosure (IMU-ISA-100C, IMU-ENC-LN200, IMU-HG1900 or IMU- $\mu$ IMU-IC) using the COM1 serial port.

This cable is applicable to SPAN systems with an IMU in the IMU Enclosure that do not require the EVENT inputs, EVENT outputs, PPS output or the other serial COM ports.

- PwrPak7 All I/O SPAN Cable (01020004)

This cable provides access to all of the signals available on the PwrPak7 26 pin D-SUB connector. Use the COM2 connector on this cable to connect the NovAtel IMU Interface cables. This connector includes the COM2 serial port signals and the additional signal required by the IMU-CPT, IMU-KVH1750 and IMU-FSAS.

### Custom IMU Interface Cable Requirements

The HD26 COM PORTS connector provides access to three serial COM ports, three EVENT inputs, three EVENT outputs, the wheel sensor input and PPS output. When selecting or building the cabling for the PwrPak7, make sure all of the required input and output signals are accounted for in the HD26 COM PORTS connector cabling design.

For information about the DB26 COM PORTS pinout, refer to the [PwrPak7 Installation and Operation User Manual](#).

For information about the IMU port pinout, refer to refer to the applicable IMU in the *IMU Technical Specifications* on page 135.

Some IMUs require an additional signal from the receiver to synchronize the receiver and IMU.

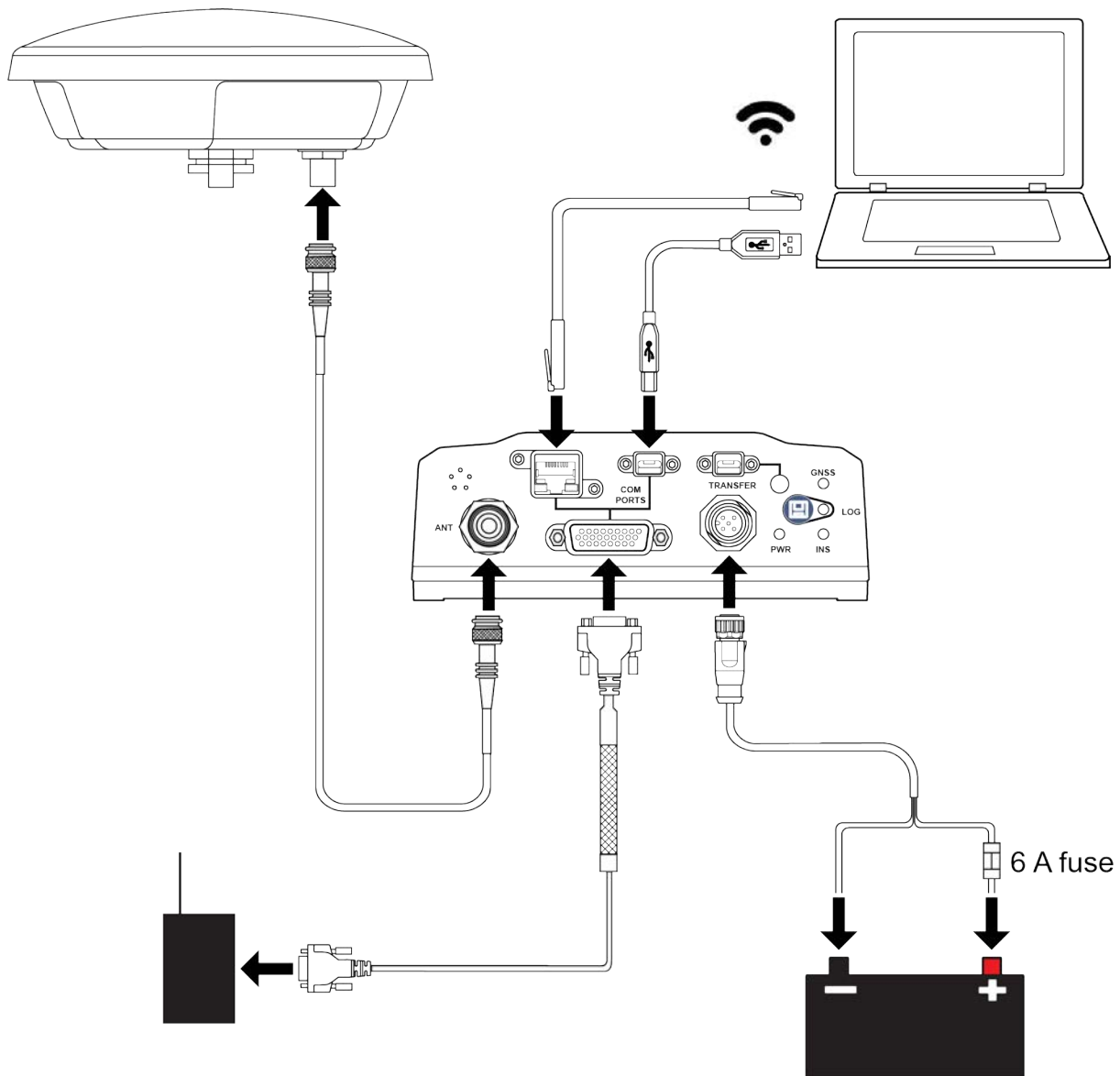
**Table 16: Additional IMU to PwrPak7 Connections**

IMU	IMU Connector		PwrPak7 DB26 COM PORTS	
	Signal Name	Pin	Signal Name	Pin
IMU-CPT	External Clock Input	36	EVENT_OUT1	16
IMU-KVH1750	MSync	11	EVENT_OUT1	16
IMU-FSAS	DAS(+)	7	EVENT_OUT1	16
IMU-STIM300D	Time of Validity	4	EVENT_IN2	23

## 2.5 PwrPak7-E1/PwrPak7-E2 Installation

The following diagram shows a typical SPAN installation using a PwrPak7-E1 or PwrPak7-E2.

**Figure 20: Typical Installation of a SPAN System with a PwrPak7-E1**



Complete the following steps to set up your NovAtel SPAN system.

1. Mount the GNSS antenna.  
See *Mounting the GNSS Antenna* on page 35 for details.
2. Mount the PwrPak7-E1/PwrPak7-E2.  
See the [PwrPak7 Installation and Operation User Manual](#) for information about mounting a PwrPak7-E1/PwrPak7-E2.
3. Connect the antenna cable from the GNSS antenna to the ANT port on the PwrPak7-E1/PwrPak7-E2. For a PwrPak7D-E1/PwrPak7D-E2, connect the primary GNSS antenna to the ANT 1 port and the

secondary GNSS antenna to the ANT 2 port.

4. Connect the I/O strobe signals (optional).

See the [PwrPak7 Installation and Operation User Manual](#) for information about connecting I/O signals to a PwrPak7.

5. Connect power to the PwrPak7-E1/PwrPak7-E2.

See *Connect Power* on page 55 for details.

6. Connect a data communication device, such a computer, to the receiver. A data communication device is used to configure and monitor the receiver.

See the [PwrPak7 Installation and Operation User Manual](#) for information about connecting a data communication device to a PwrPak7.


## 2.6 IMU LEDs

The IMU-IGM and IMU Enclosure (IMU-HG1900, IMU-ISA-100C, IMU-ENC-LN200, IMU- $\mu$ IMU-IC) have LEDs that provide the IMUs basic status information.


**Table 17: IMU-IGM LEDs**

LED	Off	On	Flash Slow (1 Hz)	Flash Fast (3 Hz)
Power (Red)	No power to unit	Unit is powered on	UNKNOWN or UNSUPPORTED IMU	Programming error
GNSS <sup>1</sup> (Green)	Waiting for GPS time	Time Status FINE or FINESTEERING	Time status COARSE, COARSESTEERING or FREEWHEELING	N/A
INS <sup>1</sup> (Green)	Not connected to IMU	Connected to IMU	N/A	Bootup or loading firmware

**Table 18: IMU Enclosure LEDs**

LED	Off	On (Red)	On (Green)	Flash Slow (Yellow, 1 Hz)	Flash Fast (Yellow, 3 Hz)
Power 	No power to IMU Enclosure.	An error occurred during boot up or initialization.	IMU Enclosure is powered on with no errors detected during boot up or initialization.	Boot up and IMU initialization.	N/A

<sup>1</sup>The IMU-IGM must be connected to a GNSS receiver before the state of these LEDs can change to On.

LED	Off	On (Red)	On (Green)	Flash Slow (Yellow, 1 Hz)	Flash Fast (Yellow, 3 Hz)
COM 	No communication between IMU Enclosure and GNSS receiver.	N/A	IMU Enclosure is transmitting and receiving data without errors.	IMU Enclosure is receiving data from the receiver, but not transmitting data.	IMU Enclosure is transmitting data to the receiver, but not receiving data.

## Chapter 3 SPAN Operation

Before operating your SPAN system, ensure that you have followed the installation and setup instructions in *SPAN Installation* on page 32.

You can use the NovAtel Connect software to configure receiver settings and to monitor data in real-time, between a rover SPAN system and base station.

SPAN system output is compatible with post-processing software from the NovAtel Waypoint Products Group. Visit our web site at [novatel.com/products/waypoint-software](http://novatel.com/products/waypoint-software) for details.



Ensure the Control Panel Power Settings on your computer are not set to go into Hibernate or Standby modes. Data will be lost if one of these modes occurs during a logging session.

### 3.1 Definition of Reference Frames Within SPAN

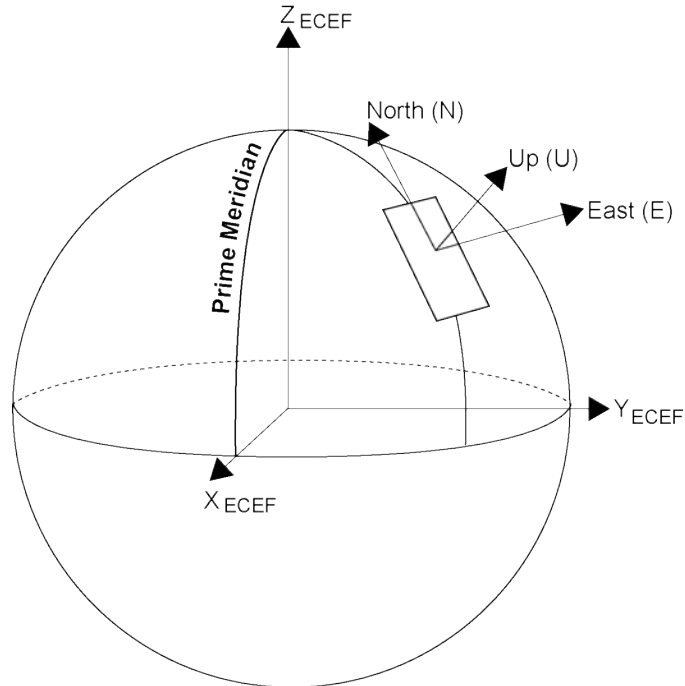
The reference frames that are most frequently used throughout the SPAN documentation are the following:

- *The Local-Level Frame (ENU)* below
- *The IMU Body Frame* on the next page
- *The Vehicle Frame* on the next page
- *The User Output Frame* on page 80

#### 3.1.1 *The Local-Level Frame (ENU)*

The definition of the local level coordinate frame is as follows:

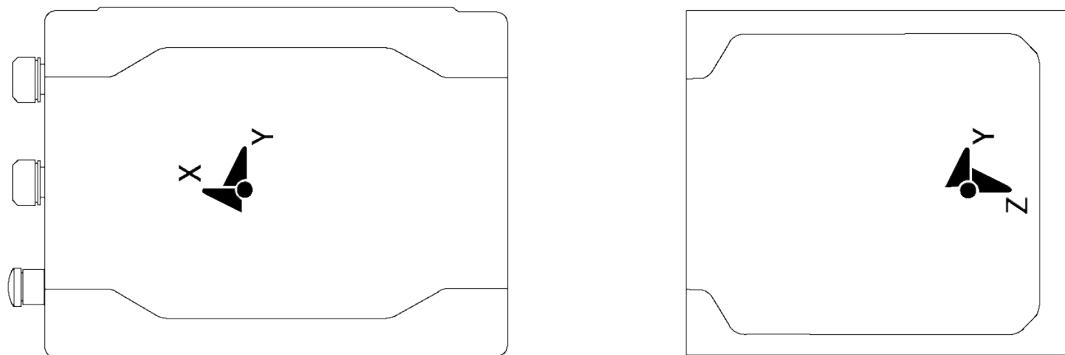
- z-axis – pointing up (aligned with gravity)
- y-axis – pointing north
- x-axis – pointing east

**Figure 21: Local-Level Frame (ENU)**

### 3.1.2 The IMU Body Frame

The definition of the IMU Body frame is given by the physical axes of the IMU and represents how the sensors are mounted inside the IMU. If your IMU is enclosed, both the IMU Body frame axes and center of navigation are marked on the enclosure. Refer to *IMU Technical Specifications* on page 135 for illustrations of the IMU Body frame axes.

The origin of this frame is not the enclosure center, but the center of navigation (sensor center).

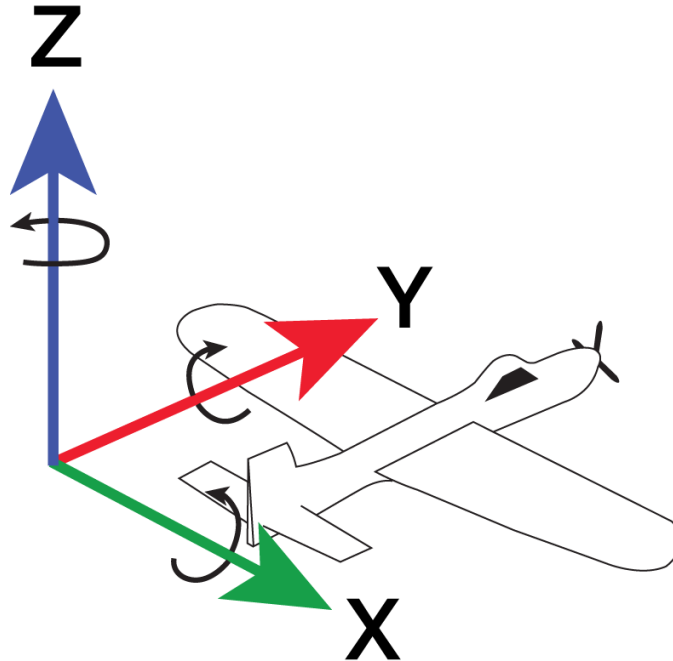
**Figure 22: IMU Body Frame Marking**

### 3.1.3 The Vehicle Frame

The definition of the vehicle frame is as follows:

- z-axis – points up through the roof of the vehicle perpendicular to the ground
- y-axis – points out the front of the vehicle in the direction of travel
- x-axis – completes the right-handed system (out the right-hand side of the vehicle when facing forward)

Figure 23: Vehicle Frame



### 3.1.4 The User Output Frame

The user output frame is an arbitrary frame, which can be optionally defined to transfer inertial output to a more useful position or reference frame.

By default, SPAN position and velocity output is given at the center of navigation of the IMU. To output position and velocity at a different location, specify a user offset translation using the **SETINSTRANSLATION** command.

By default, SPAN attitude output is the rotation from the Local-Level frame to the Vehicle frame. If attitude output is desired relative to another frame, specify a user offset rotation using the **SETINSROTATION** command.

## 3.2 SPAN Translations and Rotations

A SPAN system combines GNSS and INS into a single system. In a GNSS system, the position is reported relative to the phase center of the GNSS antenna. In an INS system, the position, velocity and attitude data is reported relative to the center of navigation of the IMU. For a SPAN system to provide a combined GNSS+INS position, velocity and attitude, it must know where the GNSS antenna is positioned relative to the IMU.

The orientation of the IMU relative to the forward direction of the vehicle is also needed to convert the velocity and attitude changes sensed by the IMU into the actual motion of the vehicle.

If the SPAN system incorporates other devices, such as a camera connected to an Event Input, the SPAN system also needs to know the location and orientation of these additional devices relative to the IMU.

### 3.2.1 Translational Offsets

The three dimensional distances between the IMU and other SPAN components are called translational offsets.

The translational offsets are measured in three directions, X axis, Y axis and Z axis, typically relative to the IMU Body frame. Translational offsets can also be entered relative to the Vehicle frame.

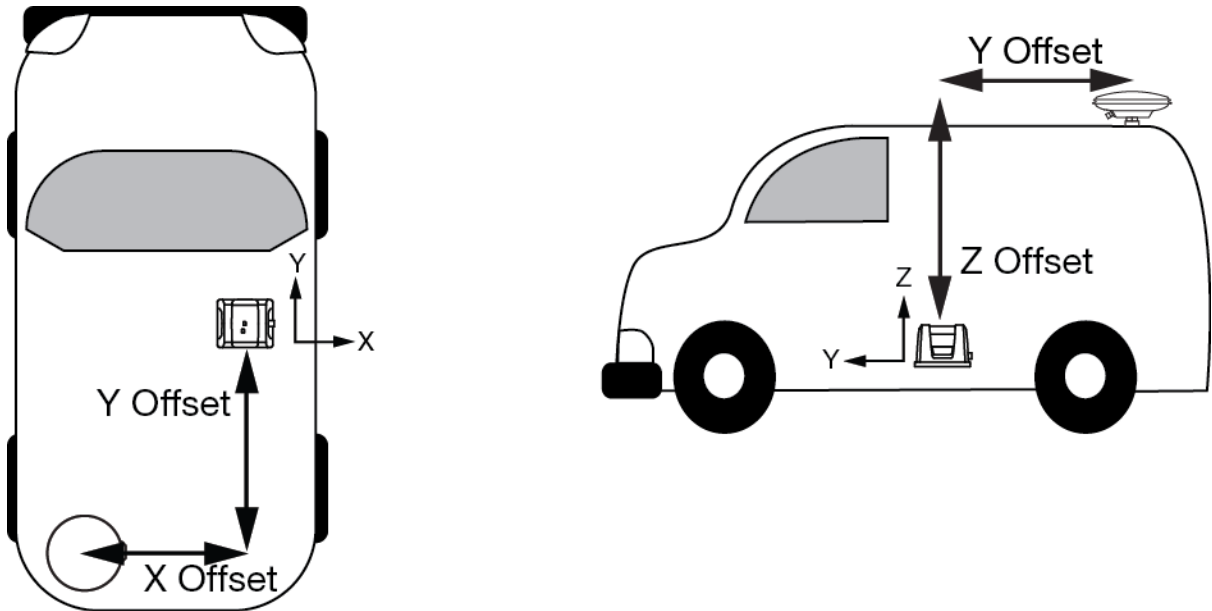




The X, Y and Z axes of the IMU Body frame are typically indicated on the IMU enclosure. The X, Y and Z axes of the IMU Body frame are also indicated on the mechanical drawings of the IMUs in the *IMU Technical Specifications* on page 135.

Figure 24: *IMU to Antenna Translation Offset* below shows an example of the translational offsets from the IMU to a GNSS antenna. In this example, the IMU Body Frame (indicated by the small arrows) has the Y axis pointing in the direction of the vehicle motion and the z axis pointing up.

**Figure 24: IMU to Antenna Translation Offset**



If the distances measured in this example were X Offset = 1.000 m, Y Offset = 1.500 m and Z Offset = 2.000 m, the following values would be entered, based on the IMU Body Frame:

- $x = -1.000$
- $y = -1.500$
- $z = 2.000$

The translational offsets are entered using the **SETINSTRANSLATION** command. For this example, the command to enter these offsets is:

```
SETINSTRANSLATION ANT1 -1 -1.5 2
```



The measurements for the translational offsets should be done as accurately as possible, preferably to within millimeters especially for RTK operation. Any error in the offsets will translate into an error in the INS position.

The translational offsets from the IMU to the GNSS antenna are required for all SPAN systems. However, some SPAN systems may have other sensors or devices integrated into the system for which the SPAN needs translational offsets. For example, a gimbal mount or a camera or LiDAR connected to an Event Input line. The offsets to these additional sensors and devices are also entered using the **SETINSTRANSLATION** command.

By default, the translational offsets are entered in the IMU Body Frame. However, in some systems the IMU Body Frame may not be known precisely. For these cases, the **SETINSTRANSLATION** command has an

option that allows the offsets to be entered relative to the Vehicle Frame. In these cases, the rotation from the IMU Body Frame to the Vehicle Frame (RBV) is used to rotate offsets into the default IMU Body frame as required. To achieve the best results, this means that the RBV rotation must be known very precisely. Typically this is achieved through the SPAN RBV Calibration procedure. See *Body to Vehicle Frame Rotation Calibration Routine* on page 103 or *Multi-Line Body to Vehicle Frame Rotation Calibration Routine* on page 104 for information about this calibration procedure.

### 3.2.2 Rotational Offsets

The differences in orientation between the IMU and other SPAN components are called rotational offsets. Rotational offsets are given as the rotation from the IMU Body Frame to the frame of interest.

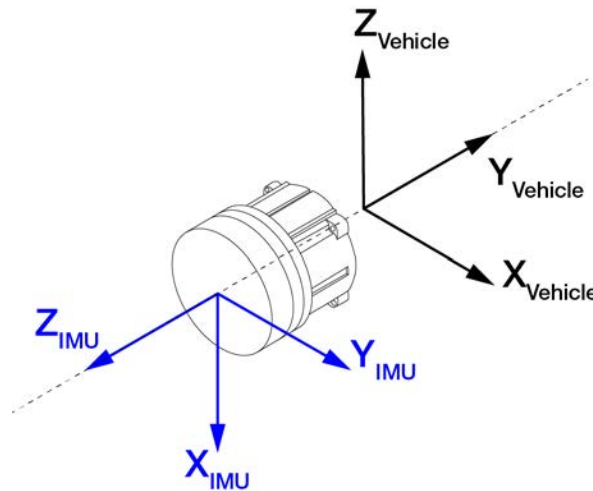


The order of rotations is Z-X-Y and all rotations are right handed.

Generally, frames of reference are defined as Z up, with Y forward, and X completing the right-handed system. An example is the vehicle frame, where Z is always considered to be upwards, Y forward through the direction of travel, and X to the right.

#### Rotational Offsets - Example

Consider an IMU installed in the following way:



Here, the Euler Angles to rotate from the IMU Body frame to the Vehicle frame (RBV) are:

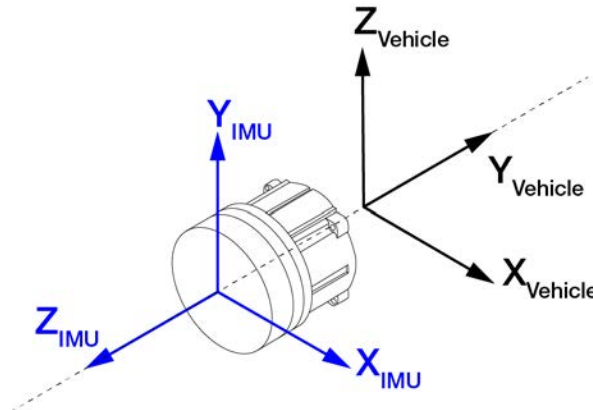
- X: -90
- Y: 0
- Z: +90

To reach this answer, keep in mind the following rules:

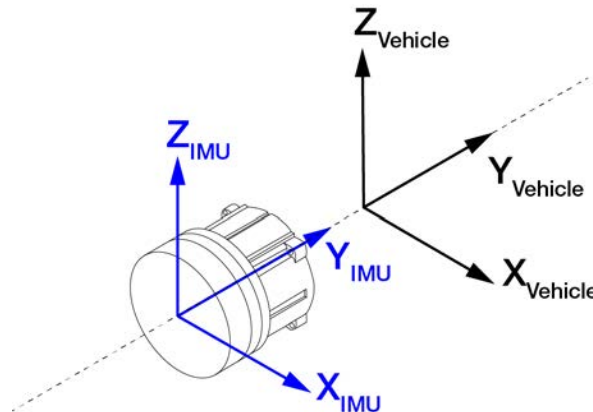
- The goal is to rotate the IMU Body frame to be coincident with the Vehicle frame (i.e. IMU X equals Vehicle X, IMU Y equals Vehicle Y, IMU Z equals Vehicle Z).
- You must rotate from the IMU Body frame to the Vehicle frame.
- You must rotate in the order Z, X, Y.
- Positive rotation is defined according to the right hand rule.

**Z Rotation:**

Observe that if a positive 90 degree rotation is performed about the IMU Z axis, the rotated IMU X axis becomes collinear with the Vehicle X axis.

**X Rotation:**

Observe that if a negative 90 degree rotation is performed about the new IMU X axis, the rotated IMU Y axis is now collinear with the Vehicle Y axis, and the rotated IMU Z axis is also collinear with the Vehicle Z axis.

**Y Rotation:**

Since all three sets of axes are already collinear, our frames are coincident, and no further rotation is required.



This solution is not unique. Due to the properties of Euler Angles, there are usually multiple sets of equivalent rotations.

The rotational offsets are entered using the **SETINSROTATION** command. For this example, the command to enter the rotations for the previous example is:

```
SETINSROTATION RBV -90 0 90
```

## 3.3 Software Configuration

On a SPAN system, both the GNSS receiver and the IMU must be configured.

### 3.3.1 GNSS Configuration

The GNSS configuration can be set up for different accuracy levels such as single point, SBAS, DGNSS, PPP and RTK. Refer to the [OEM7 Installation and Operation User Manual](#) for details on DGNSS, RTK, L-Band

or SBAS setup and operation.

With no additional configuration, the system operates in single point mode.

### 3.3.2 INS Profiles

INS Profiles provide two major functions; simplified configuration and enhanced performance. Each INS Profile sets specific filter behavior to enhance system performance in particular environments.

Basic enhancements provided by the INS Profiles are available to all SPAN enabled models and allow for simple configuration rather than sending many discreet commands.

The enhanced profile settings are enabled by the receiver model. The enhanced profile adds enhanced profile behavior such as Dead Reckoning for land and Heave for marine. A receiver model with an INS Mode of **P** or **R** is required to enable Enhanced INS Profiles.

**Table 19: OEM7 INS Profiles**

Profile	Description	Basic Profile Settings	Enhanced Profile Settings
DEFAULT	The default SPAN profile. This profile has legacy SPAN default settings.	None	N/A
LAND	INS Profile for fixed axle land vehicles. Enables robust kinematic alignment routines and configures the update profile.	Enables direction detection on kinematic alignment routine Enables course over ground attitude updates	Enables intelligent vehicle dynamics modeling for land vehicles (Dead Reckoning)
MARINE	INS profile for marine vessels. Enacts changes to disable static behavior and make the marine solution more robust.	Disable Zero Velocity Updates Disable turn-on bias estimation	Enables Heave algorithms
FIXEDWING	INS profile for fixed wing aircraft	None	None
FOOT	INS profile for walking or backpack applications	None	None
VTOL	INS profile for Vertical Take Off and Landing aircraft (helicopter, quadcopter, etc.)	None	None

Profile	Description	Basic Profile Settings	Enhanced Profile Settings
RAIL	INS profile for railway applications	Enable direction detection on kinematic alignment routine Enable course over ground attitude updates	Enables intelligent vehicle dynamics modeling for rail vehicles (Dead Reckoning)
AGRICULTURE	INS profile for agriculture applications	Enables direction detection on kinematic alignment routine Enables course over ground attitude updates	Enables intelligent vehicle dynamics modeling for agricultural vehicles (Dead Reckoning)

## Use

To use an INS Profile, send the **SETINSPROFILE** command at startup (or save to NVM) to activate the mode. For example:

```
SETINSPROFILE LAND
```

The type of profile activated, basic or enhanced, is determined by the SPAN model.



The currently selected profile option is available in the **INSCONFIG** log.

## RBV Calibration

For the profiles to provide the greatest benefit, the rotation offset of the IMU body to the vehicle frame (RBV) should be known as accurately as possible. Since constraints happen at the vehicle level, any error in the offset will translate into worse performance. These parameters are estimated in the background when the system is fully converged, however it is always better to have this measured as precisely as possible before mission critical data is collected.

The INSCALIBRATE RBV functionality can be used to estimate and save these offsets to NVM in a controlled manner.

### 3.3.3 SPAN Configuration for Receiver Cards

- *Minimum Recommended Configuration* below
- *Configure SPAN Manually* on the next page
- *SPAN Configuration with NovAtel Application Suite* on page 89
- *SPAN Configuration with NovAtel Setup & Monitor (Web)* on page 89

## Minimum Recommended Configuration

When configuring your OEM7 SPAN system for first time use, the following is the minimum amount of information required to ensure proper operation of a SPAN system.

Required Information	Required Command
IMU type and communication port	CONNECTIMU
IMU to primary antenna lever arm	SETINSTRANSALATION ANT1
IMU to vehicle frame rotation	SETINSROTATION RBV

While this is the minimum amount of information required, additional information is typically needed for SPAN systems. The following commands are commonly used to configure SPAN systems.

Common User Settings	Appropriate Command	Notes
IMU to output position offset	SETINSTRANSALATION USER	Default output position is at the IMU center
IMU to output frame rotation	SETINSROTATION USER	Default output frame is the vehicle frame
IMU to secondary antenna lever arm	SETINSTRANSALATION ANT2	Only required for dual antenna systems
Vehicle type	SETINSPROFILE	
Minimum alignment velocity	SETALIGNMENTVEL	

### Configure SPAN Manually

Follow these steps to enable INS as part of the SPAN system using software commands:



A GNSS antenna with a clear view of the sky must be connected and tracking satellites for operation.

1. Issue the **CONNECTIMU** command to specify the type of IMU being used and the receiver port connected to the IMU, see *Table 20: Enable INS Commands* below and the **CONNECTIMU** command.

**Table 20: Enable INS Commands**

IMU Type	CONNECTIMU command
ADIS-16488	CONNECTIMU COMx ADIS16488 <sup>1</sup> CONNECTIMU SPI ADIS16488 <sup>2</sup>
EG320N	CONNECTIMU SPI EPSON_G320 CONNECTIMU SPI EPSON_G320_200HZ
EG370N	CONNECTIMU SPI EPSON_G370
HG1700 AG11	CONNECTIMU COMx HG1700_AG11

<sup>1</sup>When the ADIS16488 is connected using a MIC.

<sup>2</sup>When the ADIS16488 is connected directly to an OEM7 receiver.

IMU Type	CONNECTIMU command
HG1700 AG17	CONNECTIMU COMx HG1700_AG17
HG1700 AG58	CONNECTIMU COMx HG1700_AG58
HG1700 AG62	CONNECTIMU COMx HG1700_AG62
HG1900 CA50	CONNECTIMU COMx HG1900_CA50
HG1930 CA50	CONNECTIMU COMx HG1930_CA50
HG4930	CONNECTIMU COMx HG4930_AN01
IMU-FSAS	CONNECTIMU COMx IMAR_FSAS
IMU-CPT	CONNECTIMU COMx KVH_COTS
IMU-IGM-A1	CONNECTIMU COMx ADIS16488
IMU-IGM-S1	CONNECTIMU COMx STIM300
IMU-ISA-100C	CONNECTIMU COMx ISA100C
IMU-KVH1750	CONNECTIMU COMx KVH_1750
IMU-μIMU	CONNECTIMU COMx LITEF_MICROIMU
LN-200	CONNECTIMU COMx LN200
STIM300	CONNECTIMU COMx STIM300 <sup>1</sup> CONNECTIMU COMx STIM300D <sup>2</sup>



Use the COM port number the IMU is connected to.  
If you are using the OEM719+MIC board stack, you must use COM1.  
For SPAN systems with a OEM729 receiver, COM2 is the recommended serial port for the IMU, however you can use any available port for these IMUs.

- If the SPAN system uses an OEM-HG1900 IMU connected to a MIC card, issue the following command.

```
SETIMUPORTPROTOCOL RS232
```

Basic configuration of the SPAN system is now complete. The inertial filter starts after the GNSS solution is solved and the IMU is connected.

- Issue the **SETINSTRANSLATION** command, using the **ANT1** parameter, to enter the distance from the IMU to the GNSS antenna. See the **SETINSTRANSLATION** command in the [OEM7 Commands and Logs Reference Manual](#) for more information.

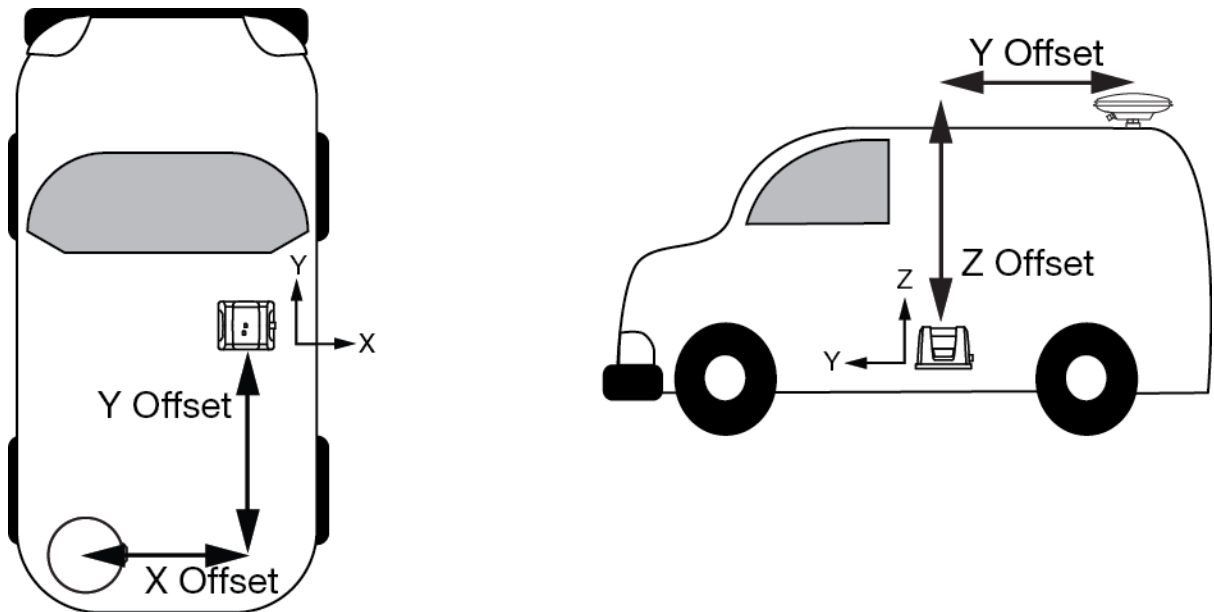
If the SPAN receiver has dual antenna inputs, issue the **SETINSTRANSLATION** command, using the **ANT2** parameter, to enter the distance from the IMU to the secondary GNSS antenna.

<sup>1</sup>When the STIM300 is connected using a MIC.

<sup>2</sup>When the STIM300 is connected directly to an OEM7 receiver.

The offset between the antenna phase center and the IMU axis must remain constant and be known accurately (m). The X, Y and Z directions are clearly marked on the IMU enclosure. The SETINSTRANSFORMATION parameters are (where the standard deviation fields are optional and the distances are measured from the IMU to the antenna):

```
ANT1 x_offset y_offset z_offset [x_stdev] [y_stdev] [z_stdev]
```



This example shows a mounting configuration with a negative X offset, negative Y offset and positive Z offset.

A typical RTK GNSS solution is accurate to a few centimeters. For the integrated GNSS+INS system to have this level of accuracy, the offset must be measured to within a centimeter. Any offset error between the two systems shows up directly in the output position. For example, a 10 cm error in recording this offset will result in at least a 10 cm error in the output.

If it is impossible to measure the IMU to GNSS antenna offset precisely, the offset can be estimated by carrying out the Lever Arm Calibration Routine. See *Lever Arm Calibration Routine* on page 102.

4. Issue the **SETINSROTATION** command, using the **RBV** parameter, to enter the Euler Angle rotation from the IMU Body frame to the Vehicle frame. See the **SETINSROTATION** command in the [OEM7 Commands and Logs Reference Manual](#) for more information.

Accurate knowledge of the rotational offset between the IMU Body frame and the Vehicle frame (the RBV rotation) is critical to correctly computing an attitude solution, and is required before a Kinematic alignment is possible.

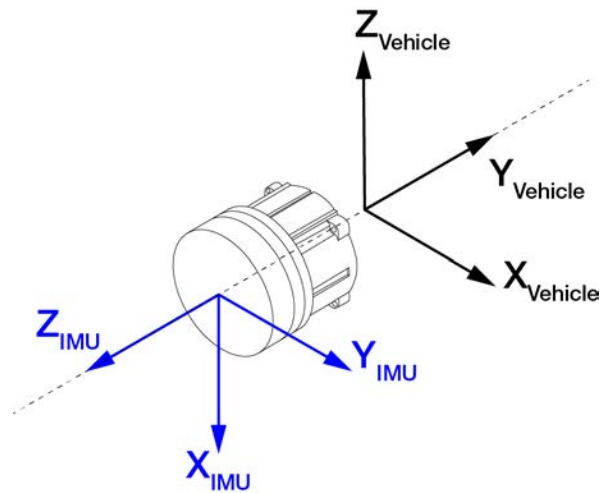
The SETINSROTATION parameters are (where the standard deviation fields are optional):

```
RBV x_rotation y_rotation z_rotation [x_stdev] [y_stddev] [z_stdev]
```



The order of rotations is Z-X-Y. All rotations are right handed.





For an example of how to solve for the IMU Body to Vehicle frame rotation refer to *Rotational Offsets* on page 82.

If the rotation between the IMU Body frame and the Vehicle frame is not precisely known, enter an approximate rotation (to the nearest 45 degrees). The precise offset can be estimated by carrying out the *Body to Vehicle Frame Rotation Calibration Routine* on page 103.

### SPAN Configuration with NovAtel Application Suite

NovAtel Application Suite provides a graphical user interface to help configure a SPAN system. For information about configuring SPAN using NovAtel Application Suite, refer to [docs.novatel.com/Tools](https://docs.novatel.com/Tools).

### SPAN Configuration with NovAtel Setup & Monitor (Web)

The SPAN parameters can be configured using the NovAtel Setup & Monitor (Web) User Interface. For information about using Setup & Monitor (Web), refer to [docs.novatel.com/Tools](https://docs.novatel.com/Tools).

#### 3.3.4 SPAN Configuration for PwrPak7

- *Minimum Recommended Configuration* below
- *Configure SPAN Manually* on the next page
- *SPAN Configuration with NovAtel Application Suite* on page 93
- *SPAN Configuration with NovAtel Setup & Monitor (Web)* on page 93

#### Minimum Recommended Configuration

When configuring your PwrPak7 system for first time use, the following is the minimum amount of information required to ensure proper operation of a SPAN system.

Required Information	Required Command
IMU type and communication port (PwrPak7 and PwrPak7D only)	CONNECTIMU
IMU to primary antenna lever arm	SETINSTRANSALATION ANT1
IMU to secondary antenna lever arm (PwrPak7D, PwrPak7D-E1 or PwrPak7D-E2 only)	SETINSTRANSALATION ANT2
IMU to vehicle frame rotation	SETINSROTATION RBV

While this is the minimum amount of information required, additional information is typically needed for SPAN systems. The following commands are commonly used to configure SPAN systems.

Common User Settings	Appropriate Command	Notes
IMU to output position offset	SETINSTRANSFORMATION USER	Default output position is at the IMU center
IMU to output frame rotation	SETINSROTATION USER	Default output frame is the vehicle frame
Vehicle type	SETINSPROFILE	
Minimum alignment velocity	SETALIGNMENTVEL	

### Configure SPAN Manually

Follow these steps to enable INS as part of the PwrPak7 system using software commands:



A GNSS antenna with a clear view of the sky must be connected and tracking satellites for operation.

1. Issue the **CONNECTIMU** command to specify the type of IMU being used and the receiver port connected to the IMU, see *Table 21: Enable INS Commands* below and the **CONNECTIMU** command.



**Do not** use the **CONNECTIMU** command on PwrPak7-E1, PwrPak7D-E1, PwrPak7-E2 or PwrPak7D-E2 receivers.

The system is configured at the factory for the internal IMU (EG320N or EG370N) and changing the IMU configuration can impair SPAN operation.

**Table 21: Enable INS Commands**

IMU Type	CONNECTIMU command
ADIS-16488	CONNECTIMU COMx ADIS16488 <sup>1</sup>
HG1700 AG11	CONNECTIMU COMx HG1700_AG11
HG1700 AG17	CONNECTIMU COMx HG1700_AG17
HG1700 AG58	CONNECTIMU COMx HG1700_AG58
HG1700 AG62	CONNECTIMU COMx HG1700_AG62
HG1900 CA50	CONNECTIMU COMx HG1900_CA50
HG1930 CA50	CONNECTIMU COMx HG1930_CA50
HG4930	CONNECTIMU COMx HG4930_AN01
IMU-FSAS	CONNECTIMU COMx IMAR_FSAS

<sup>1</sup>When the ADIS16488 is connected using a MIC.

IMU Type	CONNECTIMU command
IMU-CPT	CONNECTIMU COMx KVH_COTS
IMU-IGM-A1	CONNECTIMU COMx ADIS16488
IMU-IGM-S1	CONNECTIMU COMx STIM300
IMU-ISA-100C	CONNECTIMU COMx ISA100C
IMU-KVH1750	CONNECTIMU COMx KVH_1750
IMU- $\mu$ IMU	CONNECTIMU COMx LITEF_MICROIMU
LN-200	CONNECTIMU COMx LN200
STIM300	CONNECTIMU COMx STIM300 <sup>1</sup> CONNECTIMU COMx STIM300D <sup>2</sup>



Use the COM port number the IMU is connected to.

- Issue the **SETINSTRANSULATION** command, using the **ANT1** parameter, to enter the distance from the IMU, PwrPak7-E1, PwrPak7D-E1, PwrPak7-E2 or PwrPak7D-E2 to the primary GNSS antenna.

Issue the **SETINSTRANSULATION** command, using the **ANT2** parameter, to enter the distance from the IMU or PwrPak7D-E1 to the secondary GNSS antenna. (Required only for the PwrPak7D, PwrPak7D-E1 or PwrPak7D-E2)

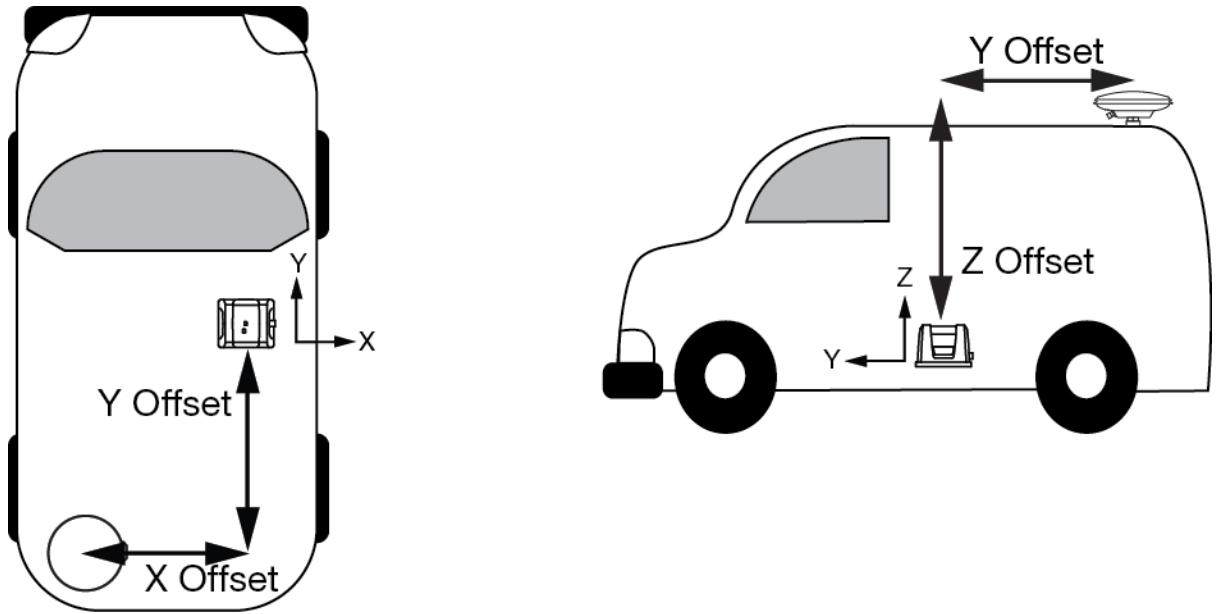
See the **SETINSTRANSULATION** command in the [OEM7 Commands and Logs Reference Manual](#) for more information.

The offset between the antenna phase center and the IMU axis must remain constant and be known accurately (m). If using a PwrPak7-E1, PwrPak7D-E1, PwrPak7-E2 or PwrPak7D-E2, the X, Y and Z directions are clearly marked on the PwrPak7 enclosure. If using a PwrPak7 or PwrPak7D and an external IMU, the X, Y and Z directions are clearly marked on the IMU enclosure. The SETINSTRANSULATION parameters are (where the standard deviation fields are optional and the distances are measured from the IMU, PwrPak7-E1, PwrPak7D-E1, PwrPak7-E2 or PwrPak7D-E2 to the antenna):

```
ANT1 x_offset y_offset z_offset [x_stdev] [y_stdev] [z_stdev]
```

<sup>1</sup>When the STIM300 is connected using a MIC.

<sup>2</sup>When the STIM300 is connected directly to the PwrPak7.



**i** This example shows a mounting configuration with a negative X offset, negative Y offset and positive Z offset.

A typical RTK GNSS solution is accurate to a few centimeters. For the integrated GNSS+INS system to have this level of accuracy, the offset must be measured to within a centimeter. Any offset error between the two systems shows up directly in the output position. For example, a 10 cm error in recording this offset will result in at least a 10 cm error in the output.

If it is impossible to measure the IMU to GNSS antenna offset precisely, the offset can be estimated by carrying out the Lever Arm Calibration Routine. See *Lever Arm Calibration Routine* on page 102.

**i** A Lever Arm Calibration Routine is not available for the PwrPak7-E1, PwrPak7D-E1, PwrPak7-E2, PwrPak7D-E2, ADIS-16488, EG320N, EG370N, HG1930, HG4930, IMU-CPT or STIM300.

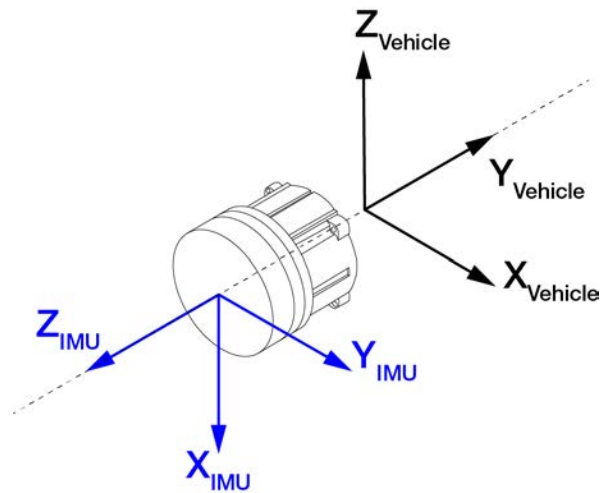
- Issue the **SETINSROTATION** command, using the **RBV** parameter, to enter the Euler Angle rotation from the IMU Body frame to the Vehicle frame. See the **SETINSROTATION** command in the [OEM7 Commands and Logs Reference Manual](#) for more information.

Accurate knowledge of the rotational offset between the IMU Body frame and the Vehicle frame (the RBV rotation) is critical to correctly computing an attitude solution, and is required before a Kinematic alignment is possible.

The SETINSROTATION parameters are (where the standard deviation fields are optional):

```
RBV x_rotation y_rotation z_rotation [x_stddev] [y_stddev] [z_stddev]
```

**i** The order of rotations is Z-X-Y. All rotations are right handed.



For an example of how to solve for the IMU Body to Vehicle frame rotation refer to *Rotational Offsets* on page 82.

If the rotation between the IMU Body frame and the Vehicle frame is not precisely known, enter an approximate rotation (to the nearest 45 degrees). The precise offset can be estimated by carrying out the *Body to Vehicle Frame Rotation Calibration Routine* on page 103.

### SPAN Configuration with NovAtel Application Suite

NovAtel Application Suite provides a graphical user interface to help configure a SPAN system. For information about configuring SPAN using NovAtel Application Suite, refer to [docs.novatel.com/Tools](https://docs.novatel.com/Tools).

### SPAN Configuration with NovAtel Setup & Monitor (Web)

The SPAN parameters can be configured using the NovAtel Setup & Monitor (Web) User Interface. For information about using Setup & Monitor (Web), refer to [docs.novatel.com/Tools](https://docs.novatel.com/Tools).

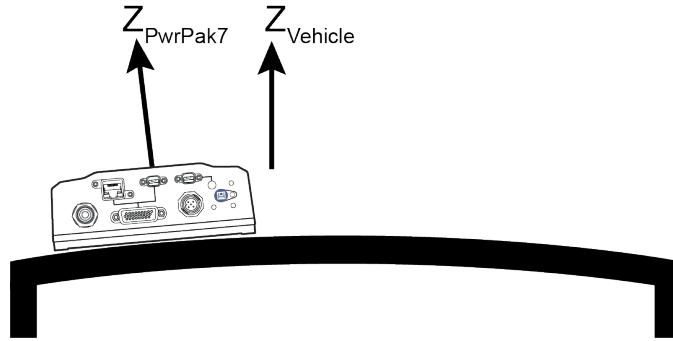
#### 3.3.5 Importance of RBV Calibration

For the SPAN system to provide the best performance, the rotation offset of the IMU body to the Vehicle frame (RBV) should be known as accurately as possible. Since constraints happen at the vehicle level, any error in the offset will translate into worse performance.

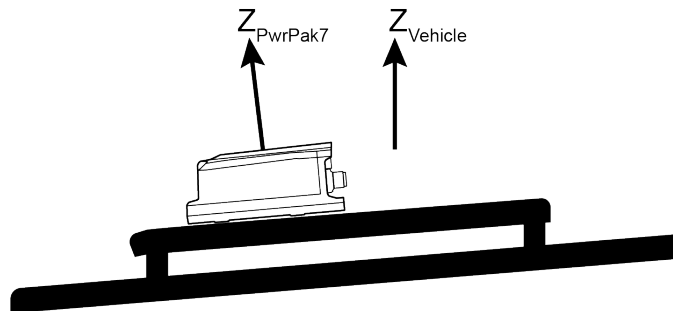
After the SPAN system has been installed and the appropriate translations and rotations have been applied (see *SPAN Configuration for Receiver Cards* on page 85 or *SPAN Configuration for PwrPak7* on page 89), the IMU Body frame is aligned with the Vehicle frame. However, aspects of the mounting platform and vehicle design, such as vehicle tilt, and slight misalignments in installation can cause the IMU Body frame to be slightly out of alignment with the Vehicle frame. The misalignment of the IMU Body frame from the Vehicle frame will add a bias to the SPAN solution.

The following diagrams show examples of a PwrPak7-E1 installed in a vehicle with misalignment issues.

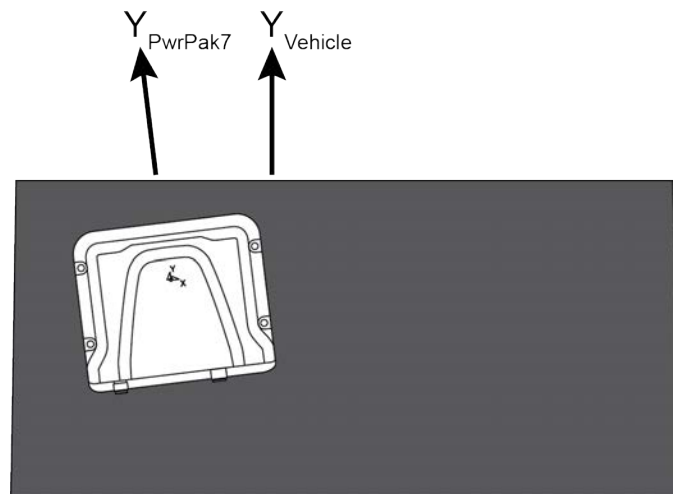
**Figure 25: Rear View of PwrPak7-E1 – Mounting Plate is not Flat**



**Figure 26: Side View of PwrPak7-E1 – Vehicle is not Level**



**Figure 27: Top View of PwrPak7-E1 – PwrPak7-E1 Misalignment**



The misalignments shown in the previous figures have been exaggerated for illustration purposes.

In a typical SPAN system installation, the slight misalignments shown in the examples above are hard to detect and difficult to measure. For this reason, it is recommended that a *Body to Vehicle Frame* rotation calibration routine be used so the SPAN system can determine and compensate for these angles. Refer to *Body to Vehicle Frame Rotation Calibration Routine* on page 103 or *Multi-Line Body to Vehicle Frame Rotation Calibration Routine* on page 104 for more information.

These parameters are estimated in the background when the system is fully converged, however it is always better to have this measured as precisely as possible before mission critical data is collected.



Since slight variations in alignment can be introduced when the IMU or PwrPak7-E1 is remounted, a Body to Vehicle Frame calibration should be performed each time the device is remounted.



An accurate RBV is especially important if the position is being transferred to a user offset.

### 3.4 Real-Time Operation

SPAN operates through the OEM7 command and log interface. Refer to the [OEM7 Commands and Logs Reference Manual](#) log and command details.

Real-time operation notes:

- By default, raw IMU data will begin to output as soon as the IMU is connected. However an initial position is required to begin the INS alignment process. This position is typically set by GNSS. The GNSS position will not be used until the FINESTEERING time status is reached. This requires a GNSS antenna connected with a clear view of the sky. See *System Start-Up and Alignment Techniques* on the next page for more details.
- The inertial solution is computed separately from the GNSS solution. The GNSS solution is available from the SPAN system through the GNSS-specific logs, even without SPAN running. The integrated GNSS+INS solution is available through special INS logs documented in INS Logs in the [OEM7 Commands and Logs Reference Manual](#).
- The IMU raw data is available at the maximum rate of output of the IMU. Because of this high data rate, a shorter header format was created. These shorter header logs are defined with an S (RAWIMUSXB rather than RAWIMUXB). We recommend you use these logs instead of the standard header logs to save throughput on the COM port.

Status of the inertial solution can be monitored using the inertial status field in the INS logs, see *Table 22: Inertial Solution Status* below.

**Table 22: Inertial Solution Status**

Binary	ASCII	Description
0	INS_INACTIVE	IMU logs are not yet present or the alignment routine is not yet initialized. INS state is inactive.
1	INS_ALIGNING	INS is in alignment mode.
2	INS_HIGH_VARIANCE	The INS solution uncertainty contains outliers and the solution may be outside specifications. The solution is still valid but you should monitor the solution uncertainty in the <b>INSSTDEV</b> log. It may be encountered during times when GNSS is absent or poor.
3	INS_SOLUTION_GOOD	The INS solution is in navigation mode and has converged sufficiently to be within specifications. For a more rigorous check of the INS solution, examine bit 6 of the Extended Solution Status word. The Extended Solution Status word is available in several logs, including <b>INSATTX</b> log, <b>INSPOSEX</b> log, <b>INSSTDEV</b> log, <b>INSSTDEVS</b> log, <b>INSVELX</b> log and <b>INSUPDATESTATUS</b> log

Binary	ASCII	Description
6	INS_SOLUTION_FREE	The INS filter is in navigation mode and the GNSS solution is suspected to be in error. This may be due to multipath or limited satellite visibility. The inertial filter has rejected the GNSS position and is waiting for the solution quality to improve.
7	INS_ALIGNMENT_COMPLETE	The INS filter is in navigation mode, but not enough vehicle dynamics have been experienced for the system to be within specifications.
8	DETERMINING_ORIENTATION	INS is determining the IMU axis aligned with gravity.
9	WAITING_INITIALPOS	The INS filter has determined the IMU orientation and is awaiting an initial position estimate to begin the alignment process.
10	WAITING_AZIMUTH	The INS filter has determined the IMU orientation, received an initial position and completed initial bias estimates. Azimuth input (from vehicle motion, dual antenna or command) is required for alignment.
11	INITIALIZING_BIASES	The INS filter has determined the IMU orientation, received an initial position and is conducting an initial IMU bias estimate.
12	MOTION_DETECT	Vehicle motion has been detected during the alignment procedure.

### 3.4.1 System Start-Up and Alignment Techniques

The system requires an initial position, velocity and attitude estimate to start the navigation filter. This is called system alignment. On start-up, the system has no position, velocity or attitude information. When the system is first powered up, the following sequence of events happens:

1. The first satellites are tracked and coarse time is solved.
2. Enough satellites are tracked to compute a position.
3. Receiver “fine time” is solved, meaning the time on board the receiver is accurate enough to begin timing IMU measurements.
4. The INS Status field changes from INS\_INACTIVE through DETERMINING\_ORIENTATION and WAITING\_INITIALPOS.
5. Once a GNSS position is available, an initial IMU bias estimate is conducted. During this period, the INS Status field reports INITIALIZING\_BIASES.
6. After the bias estimate is complete, the coarse alignment routine starts. Bias estimates will be refined and a static alignment completed, if IMU quality allows. During this period the INS Status field reports INS\_ALIGNMENT.
7. If static coarse alignment is not possible or is locked out by command, the system will require an external azimuth input, either from vehicle motion, dual antenna input or command input. While in this state the INS Status field reports WAITING\_AZIMUTH.  
  
If vehicle movement is detected, any ongoing static coarse alignment will be reset, and the INS Status field will report MOTION\_DETECT.
8. After an alignment is completed, the INS Status field changes to INS\_ALIGNMENT\_COMPLETE. The system transitions to navigation mode.



9. The solution is refined using updates from GNSS. Once the system is operating within specifications and after some vehicle movement, the INS Status field changes to INS\_SOLUTION\_GOOD. This indicates that the INS filter has successfully converged to within performance specifications.

## Coarse Alignment

The coarse alignment is the default alignment routine for SPAN. The alignment starts automatically when a GNSS solution is available, the receiver has computed fine time, the IMU is connected and configured and initial bias estimates have been completed. During the coarse alignment, accelerometer and gyro measurements are averaged over a period of time to measure Earth rotation and gravity. From these averaged measurements, initial estimates of roll, pitch and heading are computed. Because the coarse alignment uses averaged sensor output, the vehicle must remain stationary for the duration of the alignment, which is approximately 45 seconds. The attitude estimates solved by the alignment are larger than the system specified attitude accuracy and vary upon the characteristics of the sensor and the geographic latitude of the system. Attitude accuracy converges with motion after the coarse alignment is complete (see *Navigation Mode* on page 100).



The ADIS-16488, IMU-CPT, IMU-IGM, HG1930, HG4930, EG320N, EG370N, STIM300 IMUs, PwrPak7-E1, PwrPak7D-E1, PwrPak7-E2, PwrPak7D-E2 and CPT7, cannot perform coarse alignments, as these IMUs cannot accurately measure Earth rotation. For these IMUs, the default alignment routine is the kinematic alignment. Refer to *Kinematic Alignment* below. If a stationary alignment is required, refer to *Manual Alignment* on the next page.



Static Coarse alignments may be degraded due to environment, vibration or IMU age effects. Any error in initial alignment can cause performance issues.

## Kinematic Alignment

An alternate form of aligning the SPAN system is a kinematic alignment. A kinematic alignment can be used for any SPAN system and is the best alignment alternative for lower performance sensors (ADIS-16488, IMU-IGM, IMU-CPT, HG1930, HG4930, EG320N, EG370N, STIM300, PwrPak7-E1, PwrPak7D-E1, PwrPak7-E2, PwrPak7D-E2 and CPT7). The kinematic or moving alignment is performed by estimating the heading from the GNSS velocity vector and injecting it into the SPAN filter as the initial system heading.

For the kinematic alignment routine to work optimally, the course-over-ground azimuth must not include any bias from the defined Vehicle Frame. (For example, a plane being blown in the wind has a large 'crab angle' and the course-over-ground trajectory will not match the direction the IMU is pointing.)

The rotation from the IMU Body frame to the Vehicle frame (RBV) must be set to enable kinematic alignment. In order to simplify this configuration it is strongly suggested that you mount the IMU in parallel to the vehicle frame. The Y axis marked on the IMU enclosure, should point in the direction of travel.

The kinematic alignment begins when the receiver has a good GNSS position, fine time is solved, the Body to Vehicle frame rotation is known and a GNSS velocity of at least 5 m/s (~ 18 km/h) is observed. During kinematic alignment, keep the vehicle roll at less than 10°.



5 m/s is the default alignment velocity. If a different alignment velocity is required, it can be changed using the **SETALIGNMENTVEL** command. Refer to the [OEM7 Commands and Logs Reference Manual](#) for more information.

While it is possible to lower the minimum speed required for kinematic alignment to take place, the higher the value, the more closely the course-over-ground estimate will match the vehicle heading.

The accuracy of the initial attitude of the system following the kinematic alignment varies and depends on the dynamics of the vehicle. The attitude accuracy will converge to within specifications once some motion is observed by the system. This transition can be observed by monitoring the INS Status field in the INS logs.

### Dual Antenna Alignment

SPAN can also use heading information available from a NovAtel Dual Antenna ALIGN solution to rapidly perform an alignment. Refer to *SPAN with Dual Antenna* on page 130 for details.

### NVM Seeded Alignment

SPAN can use the alignment information from a previous power up to quickly perform an alignment. For information about enabling and using an NVM Seeded Alignment, refer to *INS Seed / Fast INS Initialization* below.

### Manual Alignment

If the initial azimuth of the system is known, it can be entered manually using the **SETINITAZIMUTH** command. Refer to the [OEM7 Commands and Logs Reference Manual](#) for more information about this command.



A manual alignment should be used only if the azimuth is accurately known.

### 3.4.2 INS Seed / Fast INS Initialization

The INS Seed functionality is an alignment method whereby INS alignment information from a previous powerup can be injected into the system at startup to achieve an INS alignment very quickly. This is especially useful for systems that previously required a kinematic alignment.

When INS Seed is enabled, alignment data is automatically saved when appropriate, with no specific action required from the user. During subsequent power ups, the saved solution is compared to the current position of the system, and if valid, the saved solution is used to immediately initialize the inertial filter, making it ready for use.

Error model information is also saved with the seed data. Even if full alignment cannot be achieved, this information will still be used to aid filter convergence, although another method of alignment will be required.

This feature is enabled via the **INSSEED** command. This command setting must be saved to NVM via the **SAVECONFIG** command to be used upon next system boot-up.

#### Criteria

For the INS seed functionality to be enabled, the **INSSEED ENABLE** command must be sent.

#### Saving

The following criteria must be met for valid alignment data to be saved into receiver NVM.

- The INS solution status must be converged, as indicated by the INS solution convergence flag in the inertial Extended Solution Status.
- The system velocity is less than 0.2 m/s.

When these conditions are met, the required information is automatically saved to NVM. If these conditions cease to be met, the saved alignment data is automatically discarded. If the alignment data is discarded, error model information is automatically retained as appropriate.

#### Use at Boot-up

Upon boot, several checks are done to verify that any seed data existing in NVM is appropriate for use. These checks require a GNSS position to be computed, so an NVM seed will never be injected prior to achieving a

GNSS position. The following criteria must be met in order to use a seed:

- Seed data from NVM must be valid
- The system must be stationary
- The system must not have moved significantly from the seed position: <10 meters position and 10 degrees in roll and pitch

If a valid error model is present in the seed data from NVM, this will always be used, even if the system is not stationary or exceeded the movement thresholds.



#### INJECT Option (Advanced Users Only)

There is an advanced option available to skip the second and third validation steps described in the boot-up section above. This can be used if GNSS is not available on power-up or if speed to achieve an alignment is imperative.

This option is for advanced users only. Forcing an injection of an NVM seed without the validation checks can cause an unstable INS solution if the vehicle has moved.

Apart from injecting the seed at startup without validation, this will also remove some requirements typically asserted to allow the filter to converge. This will allow the system to run without GNSS adequately at startup.

### Example Usage

Enabling functionality after FRESET:

1. Send the following command.

```
INSSEED ENABLE VALIDATE
```

2. Send the following command.

```
SAVECONFIG
```

Saving valid INS information:

1. Operate the system as normal, until the filter completes convergence.
2. Bring the system to a complete stop before powering off or resetting.

Using valid INS information on start-up:

1. Remain static while initializing.
2. Wait for the system to receive a valid position from GNSS.
3. If valid, alignment data will be injected.

### System Indicators

The **INSSEEDSTATUS** log reports the seed injection status for the current power up and information on current seed validity. Refer the [OEM7 Commands and Logs Reference Manual](#) for more information about the **INSSEEDSTATUS** log.

The Extended Solution Status field has bits that indicate the Alignment type that occurred and NVM seed injection status.

#### Alignment Type: Bits 26-28

These bits indicate how the INS system reached `INS_ALIGNMENT_COMPLETE`. When the INS system aligns using saved INS solution data from NVM, bits 26-28 will be set to 101

**NVM Seed Status: Bits 29-31**

These bits indicate the current status of the seeding process at start-up, as described in the table below:

**Table 23: NVM Seed Indication**

Bit 31-29 Values	Hex Value	NVM Seed Type
000	0x00	NVM Seed Inactive
001	0x01	Seed stored in NVM is invalid
010	0x02	NVM Seed failed validation check
011	0x03	NVM Seed is pending validation (awaiting GNSS)
100	0x04	NVM Seed Injected (includes error model data)
101	0x05	NVM Seed data ignored due to a user-commanded filter reset or configuration change
110	0x06	NVM Seed error model data injected

**3.4.3 Navigation Mode**

Once the alignment routine has successfully completed, SPAN enters navigation mode.

SPAN computes the solution by accumulating velocity and rotation increments from the IMU to generate position, velocity and attitude. SPAN models system errors by using a filter. The GNSS solution, phase observations and automatic zero velocity updates (ZUPTs) provide updates to the filter. Peripheral updates can also be supplied; wheel sensor for displacement updates or an external receiver for heading updates.

Following the alignment, the attitude is coarsely defined, especially in heading. Vehicle dynamics, specifically turns, stops and starts, allow the system to observe the heading error and allows the heading accuracy to converge. The amount of dynamics required for filter convergence vary by the alignment quality, IMU quality, and maneuvers performed. The INS Status field changes to INS\_SOLUTION\_GOOD once convergence is complete. If the filter decreases in its system accuracy, the INS Status field changes to INS\_HIGH\_VARIANCE. When the accuracy converges again, the INS status continues as INS\_SOLUTION\_GOOD.

**3.4.4 Data Collection**

The INS solution is available in the INS-specific logs with either a standard or short header. Other parameters are available in the logs shown in *Table 24: Solution Parameters* below:

**Table 24: Solution Parameters**

Parameter	Logs	
Position	INSPOS or INSPOSS INSPVA or INSPVAS	INSPOSX or INSPVAX

<sup>1</sup>The values from left to right are Bit 31, Bit 30 and Bit 29.

Parameter	Logs	
Velocity	INSVEL or INSVELS INSSPD or INSSPDS INSPVA or INSPVAS	INSVELX or INSPVAX
Attitude	INSATT or INSATTS INSPVA or INSPVAS	INSATTX or INSPVAX
Solution Uncertainty	INSSTDEV or INSSTDEVS	



The **INSATTX** log, **INSPOX** log, **INSPVAX** log and **INSVELX** log contain solution and variance information and are therefore large logs. Use a low logging rate (<20 Hz) only. These logs also contain solution uncertainty in standard deviation format.

Note that the position, velocity and attitude are available together in the **INSPVA** log, **INSPVAS** log and **INSPVAX** log.

The inertial solution is available up to a rate of 200 Hz. Data can be requested at a specific synchronous time interval, asynchronously matching the IMU output rate, or can be triggered by the mark input trigger at rates up to 200 Hz.

The GNSS-only solution is still available through the GNSS-only logs such as RTKPOS and PSRPOS. Refer to the [OEM7 Commands and Logs Reference Manual](#). INS-only data logging and output can be at rates of up to the rate of the IMU data.



The highest rate that you should request GNSS logs (RANGE, BESTPOS, RTKPOS, PSRPOS, and so on) while in INS operation is 5 Hz. If the receiver is not running INS (no IMU is attached), GNSS logs can be requested at rates up to 20 Hz.



Ensure that all windows, other than the Console, are closed in NovAtel Connect and then use the **SAVECONFIG** command to save settings in NVM. Otherwise, unnecessary data logging occurs and may overload your system.



### Logging Restriction Important Notice

Logging excessive amounts of high rate data can overload the system. When configuring the output for SPAN, NovAtel recommends that only one high rate (>50 Hz) message be configured for output at a time. It is possible to log more than one message at high rates, but doing so could have negative impacts on the system. Also, if logging 100/200 Hz data, always use the binary format and, if possible, the short header binary format (available on most INS logs).

For optimal performance, log only one high rate output at a time. These logs could be:

- Raw data for post processing  
RAWIMUXSB ONNEW (output rate depends on IMU see *Table 2: SPAN-Compatible IMUs* on page 30)
  - RAWIMU logs are not valid with the ONTIME trigger. The raw IMU observations contained in these logs are sequential changes in velocity and rotation. As such, you can only use them for navigation if they are logged at their full rate. Refer to the [OEM7 Commands and Logs Reference Manual](#) for log and command details.
- Real time INS solution  
IMURATEPVA ONNEW or IMURATEPVAS ONNEW
  - Other possible INS solution logs available at high rates are: INSPVASB, INSPOSSB, INSVELSB, INSATTSB

Specific logs need to be collected for post-processing. See *Data Collection for Post Processing* on page 122.

To store data from an OEM7 receiver, connect the receiver to a computer running NovAtel Connect or other terminal program capable of recording data. On PwrPak7 receivers, you can also collect data on internal memory.

### 3.4.5 Lever Arm Calibration Routine

Each time the system is re-mounted on a vehicle, or the IMU or antenna is moved on the vehicle, the lever arm must be redefined either through manual measurement or through calibration.



We recommend that you measure the lever arm using survey methodology and equipment, for example, a total station. Only use calibrations when precise measurement of the lever arm is not possible.

Initial estimates and uncertainties for the lever arm may be entered using the **SETINSTRANSLATION ANT1** command. The calibration routine uses these values as the starting point for the lever arm computation.



The Lever Arm Calibration routine is not available for the IMU-CPT, HG1930, HG4930, ADIS-16488, EG320N, EG370N, IMU-IGM, STIM300, PwrPak7-E1, PwrPak7D-E1, PwrPak7-E2, PwrPak7D-E2 or CPT7.

The steps involved in the calibration are:

1. Apply power to the receiver and the IMU.
2. Configure the SPAN system, see *SPAN Configuration for Receiver Cards* on page 85.
3. Enter the initial estimate for the lever arm using the **SETINSTRANSLATION ANT1** command.

Ensure the standard deviation values entered for the antenna offset are not overly optimistic (i.e., err on the side of a larger standard deviation).

4. Perform an initial system alignment using one of the methods described in *System Start-Up and Alignment Techniques* on page 96. Ensure the system reaches Solution Good.
5. Enable calibration using the **INSCALIBRATE** command with an optional standard deviation target. For example, choose a standard deviation target of 0.05 m.

```
INSCALIBRATE ANT1 NEW 0.05
```

6. To monitor the calibration, log **INSCALSTATUS** using the ONCHANGED trigger.
7. Start to move the system. The lever arm is not observable while the system is stationary. Immediately, drive a series of maneuvers such as figure eights. The turns should alternate between directions, and you should make an equal number of turns in each direction. Some height variation in the route is also useful for providing observability in the Z-axis.
8. When the calibration is complete, either because the accuracy requirement has been met, or the calibration has been halted by user command, the calibrated offset value can be viewed in either the **INSCALSTATUS** log or the **INSCONFIG** log.

To save a calibrated lever arm for subsequent start ups, issue the **SAVECONFIG** command after calibration is complete. If the IMU or GNSS antenna are re-mounted, re-run the calibration routine to compute an accurate lever arm.



An accurate Lever Arm calibration depends on observability in all axes. Often, it can be very challenging to achieve sufficient dynamics during a calibration (e.g. a land vehicle can not normally achieve the same dynamics vertically as horizontally). To overcome this limitation, complete multiple calibrations and average the results (see also **INSCALIBRATE ADD** or do so manually). The calibrated values for axes with poor observability will likely have a large range of results not reflected in the final standard deviation value. Another method that may obtain a better result for these axes is to set the standard deviation target very low (i.e. 0.01) and run the calibration for a long time (at least 15 minutes). In this case, the calibration may not converge (reach CALIBRATED), but the convergence can be observed and a final value chosen appropriately.



For information about the logs and commands used in this procedure, refer to the [OEM7 Commands and Logs Reference Manual](#).

### 3.4.6 Body to Vehicle Frame Rotation Calibration Routine

Kinematic alignment requires that the rotational offset between the vehicle and IMU Body frame (RBV) is known. If the angles are simple (that is, a simple rotation about one axis) the values can easily be entered manually through the **SETINSROTATION RBV** command. If the rotational offset is more complex (that is, rotation is about 2 or 3 axis), then the calibration routine provides a more accurate estimation of the values.

The steps for the calibration routine are:

1. Apply power to the receiver and IMU.
2. Configure the SPAN system including an approximate IMU Body to Vehicle frame (RBV) rotation. See *SPAN Configuration for Receiver Cards* on page 85.
3. Ensure that an accurate lever arm has been entered into the system either manually or through a lever arm calibration, see *Lever Arm Calibration Routine* on the previous page.
4. Perform an initial system alignment using one of the methods described in *System Start-Up and Alignment Techniques* on page 96. Ensure the system reaches Solution Good.

5. Enable calibration using the **INSCALIBRATE** command with an optional standard deviation target.

```
INSCALIBRATE RBV NEW [target_stdev]
```

6. To monitor the calibration, log INSCALSTATUS using the ONCHANGED trigger.
7. Start to move the system. As with the lever arm calibration, movement of the system is required for the observation of the angular offsets.

Drive a straight course on level ground (remember that most roads have a crown resulting in a constant roll of a few degrees). Avoid driving on a surface with a constant, non-zero, slope to prevent biases in the computed angles. Vehicle speed must be greater than 5 m/s (18 km/hr) for the calibration to complete.

8. When the calibration is complete, either because the accuracy requirement has been met, or the calibration been stopped by user command (**INSCALIBRATE** command), the calibrated offset value is automatically applied can be viewed in either the **INSCALSTATUS** log or the **INSCONFIG** log.

To save a calibrated rotation for subsequent start ups, issue the **SAVECONFIG** command after calibration is complete. Each time the IMU is re-mounted this calibration should be performed again. See also *Coarse Alignment* on page 97 and *Kinematic Alignment* on page 97 for details on coarse and kinematic alignment.



After the **INSCALIBRATE RBV ENABLE** command is entered, there are no body-vehicle rotation parameters present and a kinematic alignment is NOT possible. Therefore this command should only be entered after the system has performed either a static or kinematic alignment and has a valid INS solution.



As with the **SETINSROTATION** command, the minimum standard deviation that will be applied is 0.25 degrees (as viewed in the **INSCONFIG** log), even though the **INSCALSTATUS** log may report lower standard deviations after a successful calibration.



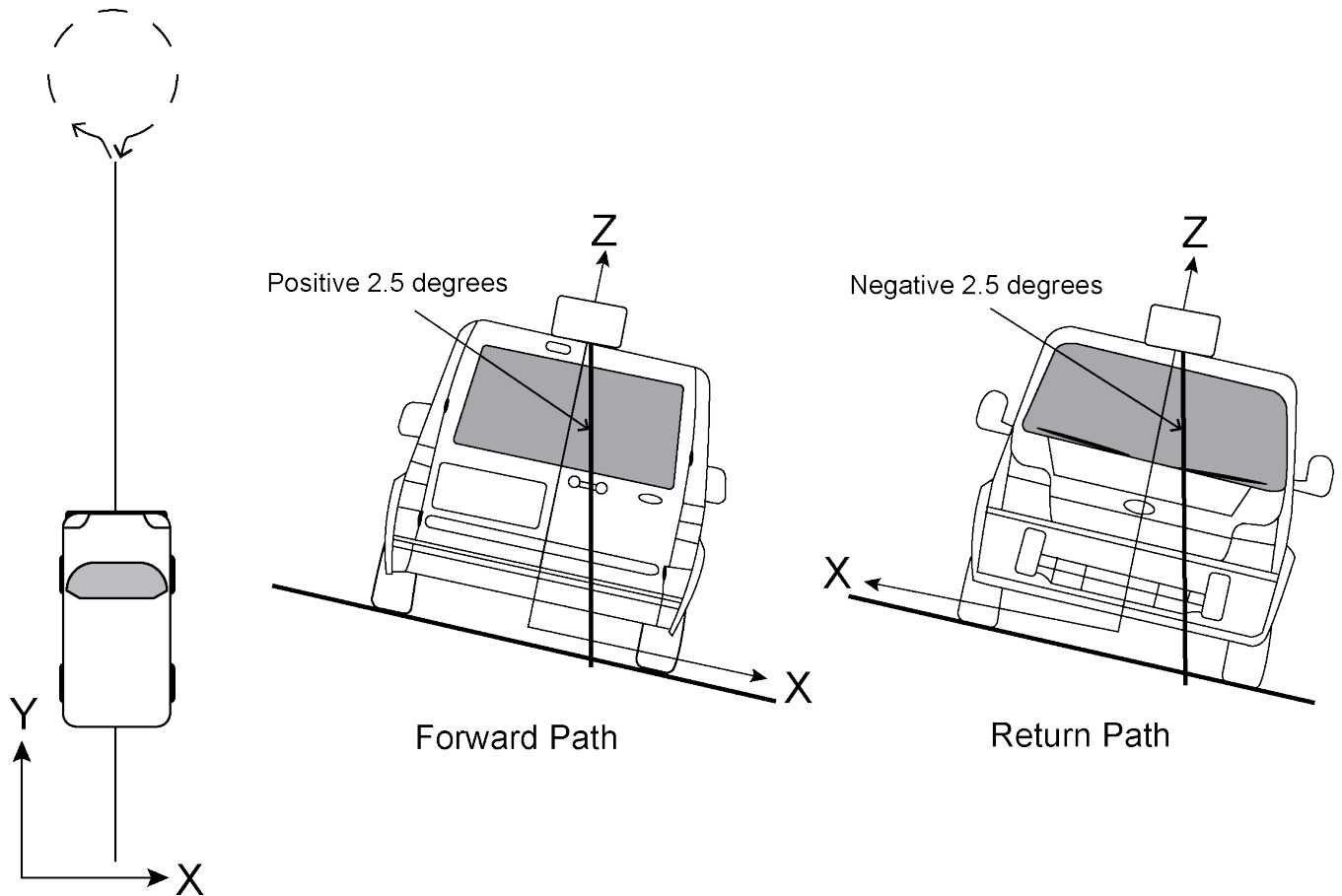
For information about the logs and commands used in this procedure, refer to the [OEM7 Commands and Logs Reference Manual](#).

### 3.4.7 Multi-Line Body to Vehicle Frame Rotation Calibration Routine

The single pass Body to Vehicle frame offset calibration feature assumes flat ground when estimating the roll offsets between the IMU Body and Vehicle frames, as this component of the rotational offset is difficult to observe through typical ground vehicle motion. In practice this can result in an outstanding roll offset error as high as several degrees. For applications where vehicle roll must be well known, or pass-to-pass accuracy of a highly offset position is especially important, the Multi-Line IMU Body to Vehicle frame offset calibration routine offers higher calibrated accuracy in roll. This is done by running independent calibrations over the same ground path in opposite directions; averaging the results cancels out the effect of any terrain induced roll. A minimum of two iterations are required. Additional iteration pairs can be executed for increased reliability.



Figure 28: Multi-Line IMU Body to Vehicle Calibration



The steps for the calibration routine are:

1. Apply power to the receiver and IMU.
2. Configure the SPAN system, see *SPAN Configuration for Receiver Cards* on page 85.
3. Ensure that an accurate lever arm has been entered into the system either manually or through a lever arm calibration, see *Lever Arm Calibration Routine* on page 102.
4. Perform an initial system alignment using one of the methods described in *System Start-Up and Alignment Techniques* on page 96. Ensure the system reaches Solution Good.
5. Enable a new calibration using the **INSCALIBRATE** command, with the optional standard deviation target omitted:

```
INSCALIBRATE RBV NEW
```

6. Start to move the vehicle. Drive a straight course, at a vehicle speed greater than 5 m/s (18 km/hr). A distance of approximately 250 meters is recommended.

To monitor the calibration, log **INSCALSTATUS** using the ONCHANGED trigger.

7. When the end of the available distance is reached, stop the vehicle. Halt the ongoing calibration by sending the **INSCALIBRATE** command again:

```
INSCALIBRATE RBV STOP
```

8. At this point **INSCALSTATUS** will report a source status of CALIBRATED. Turn the vehicle around and come to a stop on the finishing point of the previous line.
9. Initiate the second pass of the calibration by issuing the **INSCALIBRATE** command with the **ADD** parameter:

```
INSCALIBRATE RBV ADD
```

10. Drive the vehicle back along the original course, until you reach the starting point for the first pass. Stop the vehicle, and re-issue the **INSCALIBRATE** command, with the **STOP** parameter. **INSCALSTATUS** will again indicate a source status of CALIBRATED.

At this point the Multi-Line calibration can be considered complete, but more iterations can be repeated until the desired accuracy level is reached.

At any point during an active calibration line, the **INSCALIBRATE** command, with the **RESET** parameter can be used to reset the calibration. This will ensure that the results of the active line are not added to the Multi-Line calibration. The **INSCALSTATUS** log will restore the previous source status and calibration values.

11. When the calibration is complete, the calibrated offset value can be viewed in either the **INSCALSTATUS** log or the **INSCONFIG** log.

To save a calibrated rotation for subsequent start ups, issue the **SAVECONFIG** command after calibration is complete. Each time the IMU is re-mounted this calibration should be performed again.



After the **INSCALIBRATE RBV ENABLE** command is entered, there are no body-vehicle rotation parameters present and a kinematic alignment is NOT possible. Therefore this command should only be entered after the system has performed either a static or kinematic alignment and has a valid INS solution.



For information about the logs and commands used in this procedure, refer to the [OEM7 Commands and Logs Reference Manual](#).

## 3.5 Synchronizing External Equipment

A SPAN system allows you to synchronize with external equipment.

All SPAN receivers accept input pulses (events). Each event signal can be configured for positive or negative polarity. Time, or a solution (position, velocity, attitude), can be generated and output with each input pulse.

### 3.5.1 Configuring an Input Strobe

SPAN systems have several input strobes. The input strobes apply an accurate GNSS time to the rising, or falling, edge of an input pulse called an event. For each event, an accurate position, velocity or attitude solution is also available. Each input strobe is usually associated with a separate device, therefore different solution output lever arm offsets can be applied to each strobe.

Each input strobe can be configured using the **EVENTINCONTROL** command for the following parameters:

**Polarity:**

When polarity is set to positive, events trigger on the rising edge. When polarity is set to negative, events trigger on the falling edge.

**Time Bias (t\_bias):**

A constant time bias in nanoseconds can be applied to each event pulse. Typically this is used to account for a transmission delay.

**Time Guard (t\_guard):**

The time guard specifies the minimum number of milliseconds between pulses. This is used to coarsely filter the input pulses.

The time of the input pulses is available from the **MARKTIME**, **MARK2TIME**, **MARK3TIME** and **MARK4TIME** log. The solution synchronous with the event pulses is available from the **MARK1PVA**, **MARK2PVA**, **MARK3PVA** and **MARK4PVA** log. The logs required for input strobes are:

**LOG MARK1TIMEB ONNEW**

Output time for every pulse received.

**LOG MARK1PVAB ONNEW**

Output time, position, velocity and attitude for every pulse received at the location specified by the **SETINSTRANSLATION** command and **SETINSROTATION** command.

The above example is for the MARK1 event input. The minimum detectable pulse duration must be greater than or equal to 1 microsecond.



The input signal levels are 3.3 V to 0 V. Signal voltages outside these bounds damage the receiver.



For information about the logs and commands used in this procedure, refer to the [OEM7 Commands and Logs Reference Manual](#).

## 3.6 Adding Timed Sensor Triggers

Use the EVENT IN and EVENT OUT connections to attach up to three sensor devices to an OEM7 receiver and then trigger the sensors based upon GPS time.

In this context a 'sensor' is any external device. The 'sensor' reference in the receiver is an object consisting of an Event\_In and Event\_Out pair of system strobes all linked by a sensor identifier.

You can send multiple trigger events marked with a user-specified ID and a GPS time to trigger the sensor. At the requested trigger time, the receiver outputs a user-specified LVCMOS level pulse to the sensor and waits for a response pulse to indicate a sensor measurement (i.e. camera exposure). When this response is received, the SPAN system outputs a log with the inertial position/velocity/attitude and the ID of the event.

### 3.6.1 Configuring the Hardware

A sensor's trigger input is connected to a valid Event\_Out and the sensor's response output is connected to a valid Event\_In. Three sensor slots are available for use, but may be limited to less depending on the hardware platform used.

**Table 25: Valid Event Inputs and Outputs for Timed Sensor Triggers**

Valid Event Outputs	Valid Event Inputs
MARK1	MARK1

Valid Event Outputs	Valid Event Inputs
MARK2	MARK2
MARK3	MARK3
MARK4	MARK4

### 3.6.2 Configuring the Software

Sensor objects are defined by using the **SETUPSENSOR** command. This command allows the Event\_In and Event\_Out lines to be specified as well as some parameters for the outgoing and incoming signals.



After configuring a sensor using the **SETUPSENSOR** command, any other commands that affect the selected event lines will disturb this functionality. For example, if MARK2 Out is selected for a sensor, but later the **EVENTOUTCONTROL** command is sent, the **EVENTOUTCONTROL** command will reconfigure the properties of the MARK2 line.

### 3.6.3 Using Timed Event Pulses

When sensors have been connected and configured, use the **TIMEDEVENTPULSE** command to queue events on the system. **TIMEDEVENTPULSE** specifies the sensors that are affected, the GPS time for the desired event (in weeks and seconds), and an event ID. You can queue 10 unprocessed events at a time. Any time input specified via this command must occur at least 1 second after the command is entered.

The timing accuracy of the **TIMEDEVENTPULSE** output is 2 milliseconds.

### 3.6.4 Recording Incoming Sensor Events

After a **TIMEDEVENTPULSE** is sent, the system can be configured to accept an incoming pulse from the sensor in order to produce a time and ID tagged inertial solution associated to that event. This is optional and useful if a sensor provides a measurement TOV pulse. The produced log is a TAGGEDxMARKPVA where the 'x' is the Event\_In line associated with that sensor (via the **SETUPSENSOR** command).

For example, if the **SETUPSENSOR** command specifies SENSOR1 to use MARK1 in as the input event then a TAGGEDMARK1PVA log will be produced when any pulses on that line are observed. In this case the TAGGEDMARK1PVA log should be requested ONNEW to capture the data.

## 3.7 Distance Measurement Instrument

A Distance Measurement Instrument (DMI) can provide additional accuracy and reliability to a NovAtel SPAN solution.

Typically, a DMI measures the distance traveled and represents the measurement using digital pulses. For a land vehicle, where a DMI is also known as a wheel sensor, the pulses are referred to as wheel ticks. If the pulses are accumulated and the size of the wheel known, a displacement of the wheel over time can be calculated. The SPAN system takes in a DMI input and applies a displacement update to the GNSS+INS Kalman filter in order to constrain the position error growth during GNSS outages. SPAN also automatically estimates the size of the wheel to mitigate small changes in the size of the wheel due to hardware changes or environmental conditions.

A DMI with a higher accuracy will have more wheel ticks per revolution. For example, assume a wheel with a circumference of 2 meters and a DMI rated for 1000 ticks per revolution. The DMI will output 1000 pulses per com-

plete revolution of the wheel. The resulting precision will be 0.002 m/tick. Given the same wheel, but a DMI rated for 10 ticks per revolution, the resulting precision will be 0.2 m/tick.

### 3.7.1 DMI Communication

Quadrature encoding is a widely used DMI data transmission method. Quadrature encoding uses two channels. This method allows for the directionality of the DMI to be determined, resulting in a more stable DMI update to the SPAN solution when compared to a single channel configuration. Quadrature encoding is supported on NovAtel products using differential signal pairs per channel. The differential pair improves robustness in challenging electrical environments.

NovAtel products that support quadrature encoding also accept a single channel DMI input. In the case of a single channel, only the A+/A- differential wire pair is connected. A single channel provides benefit to the SPAN solution by measuring only the distance traveled without regard for direction.

### 3.7.2 DMI Connection

Depending on the SPAN system components, the DMI can be connected to a PwrPak7, an IMU, a UIC or an intermediate processor.

- PwrPak7

For a SPAN system with a PwrPak7, the DMI can be connected to the HD26 COM PORTS connector on the PwrPak7.

For information about connecting and configuring a DMI connected to a PwrPak7, see *DMI Connected to a PwrPak7* on page 111.

- IMU Enclosure

For a SPAN system with an IMU-HG1900, IMU-ISA-100C, IMU-ENC-LN200 or IMU- $\mu$ IMU-IC, the DMI can be connected to the Wheel Sensor port on the IMU enclosure.

For a SPAN system with an IMU-IGM-A1 or IMU-IGM-S1, the DMI is connected to the AUX port on the enclosure.

For a SPAN system with an IMU-FSAS or IMU-CPT, the DMI can be connected to the IMU connector.

For information about connecting and configuring a DMI connected to an IMU, see *DMI Connected to an IMU* on page 113.

- Universal IMU Controller (UIC)

For a SPAN system that uses a UIC to connect the IMU to the receiver, the DMI can be connected to the UIC.

For information about connecting and configuring a DMI connected to a UIC, see *DMI Connected to a UIC* on page 115.

- Intermediate processor

NovAtel's OEM7 receiver cards do not handle DMI encoded signals natively. If using a receiver card, an intermediate processor is required to convert DMI pulses into NovAtel commands (RAWDMI).

For information about connecting and configuring a DMI connected using an intermediate processor, see *DMI Connected to an Intermediate Processor* on page 117.

### 3.7.3 DMI Requirements

The PwrPak7, UIC and certain IMU enclosures are compatible with any wheel sensor meeting the following requirements:

- Output signal duty cycle is symmetric 40% to 60%.
- Output signal voltage is RS-422 compliant (differential).

- The wheel sensor is powered externally. The receiver does not supply power to the wheel sensor.
- Quadrature, pulse and direction wheel sensors are compatible.
- Expected maximum pulse rate over measurement range does not exceed the product-dependent limit described in *Table 26: Wheel Sensor Maximum Pulse Rates* below.

**Table 26: Wheel Sensor Maximum Pulse Rates**

Product	Maximum Pulse Rate
PwrPak7	100,000 Hz
MIC, UIC, IMU-H1900, IMU-IGM-A1, IMU-IGM-S1, IMU-ISA-100C, IMU-ENC-LN200, IMU- $\mu$ IMU-IC	300,000 Hz
IMU with direct wheel sensor support	See IMU documentation

An example of a compatible DMI is the Kistler Wheel Pulse Transducer CWPTA411 (WPT). See *Figure 29: Kistler WPT* below.

- A transducer traditionally fits to the outside of a non-drive wheel. A pulse is then generated from the transducer which is fed to the receiver.
- The WPT mounts to the wheel lug nuts via adjustable mounting collets. The torsion protection rod, which maintains rotation around the wheel axis, affixes to the vehicle body with suction cups. Refer to the Kistler WPT (part number CWPTA411) user manual for mounting instructions.

**Figure 29: Kistler WPT**

Kistler provides an M12 to DB9 cable for use with the WPT DMI. However, certain revisions of this cable do not bring through all four signal inputs. SPAN systems require at a minimum the A+ and A- signals for distance. All four signal inputs are required to measure both distance and direction correctly. See your WPT documentation for cable details.

Table 27: Kistler to NovAtel Wheel Sensor Cable Connections

Kistler Cable		PwrPak7	IMU Enclosure		IMU-FSAS
M12 Connector		All I/O Cable	M12 Connector on NovAtel Cable		Female DB9
Pin	Signal	Wire Label	Pin	Wire Color	Pin
Pin 1	GND	External	External		External
Pin 2	+U <sub>B</sub> (Input Power)				
Pin 3	Signal A+	Wheel Sensor A+	Pin 1	White	Pin 6
Pin 4	Signal A-	Wheel Sensor A-	Pin 4	Yellow	Pin 7
Pin 5	Signal B+	Wheel Sensor B+	Pin 2	Brown	Pin 3
Pin 6	Signal B-	Wheel Sensor B-	Pin 5	Grey	Pin 1
Pin 7	Reserved	No Connection	No Connection		No Connection
Pin 8					



This modification is for the Kistler WPT 8-pin M12-plug cable number 14865.



The WPT requires power to operate, which is not supplied through the receiver or IMU. Pins 1 and 2 should therefore be connected to an external power supply (+10 to +30 VDC).

### 3.7.4 DMI Connected to a PwrPak7

A DMI can be used with any SPAN enabled PwrPak7 receiver. This includes PwrPak7 receivers with an internal IMU (such as a PwrPak7-E1) or PwrPak7 receivers with an external IMU.



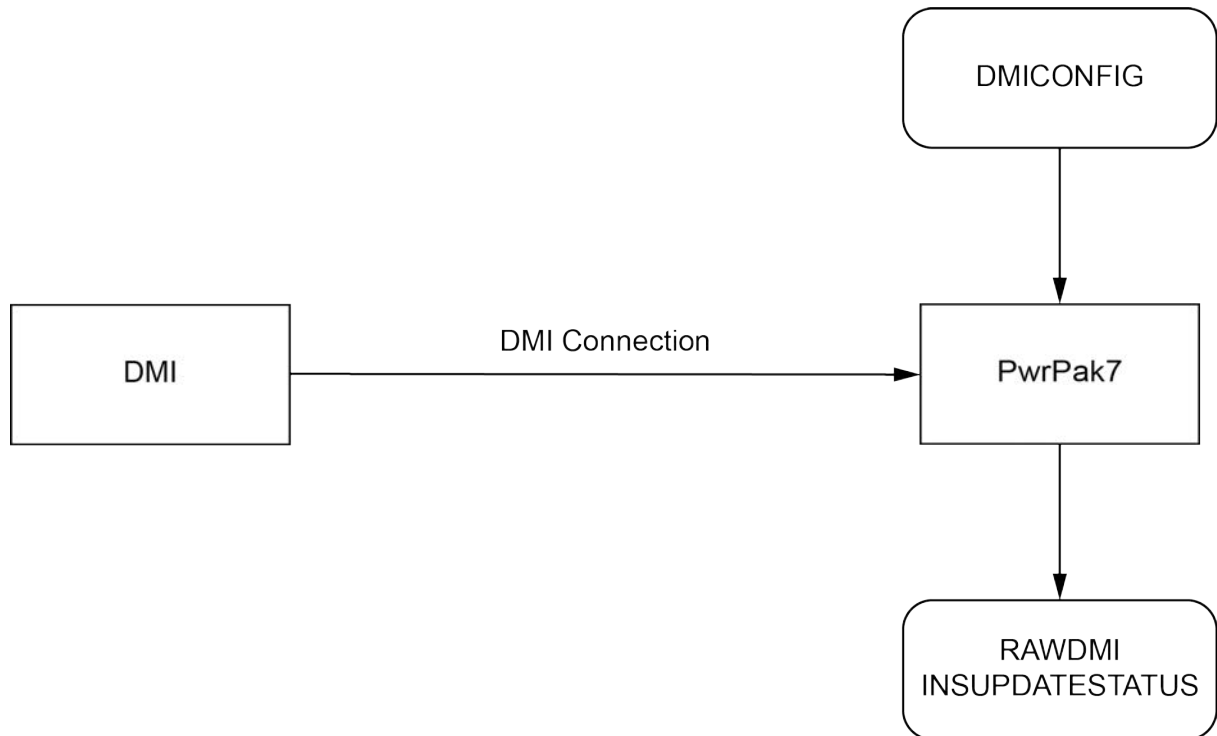
When using a PwrPak7 with an external IMU, the DMI can be connected to the PwrPak7 or the IMU. If connecting the DMI to the IMU, refer to *DMI Connected to an IMU* on page 113.



The PwrPak7 can accept DMI data from only one DMI. If connecting the DMI to the PwrPak7, do not connect a second DMI to the external IMU.

Figure 30: DMI to PwrPak7 Setup on the next page shows an overview of a DMI connected to a PwrPak7.

Figure 30: DMI to PwrPak7 Setup



The DMI connections are A+, A-, B+, B- and GND for quadrature or A+, A- and GND for single channel.

### DMI Data Collected on the PwrPak7

Typical DMI hardware generates wheel ticks constantly as the wheel rotates. The PwrPak7 interface is configured to accumulate wheel tick counts at a rate of 1 Hz.

### DMI Update Logic

DMI data is available through the **RAWDMI** log. The **RAWDMI** log can be used for applying DMI updates in post-processing.

The SPAN filter uses sequential **RAWDMI** logs to compute a distance traveled between update intervals (1 Hz). This information is used to constrain free inertial drift during times of poor GNSS visibility. The filter also contains a state for modeling the circumference of the wheel as it may change due to hardware changes or environmental conditions.

Information about how the DMI updates are being used is available in the **INSUPDATESTATUS** log.

### Connect the DMI to a PwrPak7

The PwrPak7 DMI inputs are RS-422 differential inputs. Refer to the [PwrPak7 Installation and Operation User Manual](#) for the required input voltages.

To connect a DMI:

1. Connect the PwrPak7 All I/O Cable, or custom interface cable, to the HD26 COM PORT connector on the PwrPak7.



For information about creating a custom interface cable, see the [PwrPak7 Installation and Operation User Manual](#).

2. Connect the wheel sensor wires on the interface cable to the DMI.

For a quadrature configuration, connect the DMI to the Wheel Sensor A+, Wheel Sensor A-, Wheel Sensor B+, Wheel Sensor B- and GND wires.

For a single channel configuration, connect the DMI to the Wheel Sensor A, Wheel Sensor A- and GND wires.

3. Connect an external power supply to the DMI.

The power required for the DMI depends on the DMI used. Refer to the DMI user documents for more information.

### Configure a DMI

1. Send the following command to enable a DMI on the PwrPak7 wheel sensor inputs.

```
DMICONFIG DMI1 ENABLE ENCLOSURE
```

2. Send the following commands to log the DMI data.

```
LOG DMICONFIGA ONCHANGED
```

```
LOG RAWDMIA ONNEW
```

```
LOG INSUPDATESTATUSA ONNEW
```

3. Check the **RAWDMI** log to ensure the DMI is producing data.
4. Check the **INSUPDATESTATUS** log to ensure the DMI is being used in the SPAN solution.

If there is no DMI data being produced or the DMI status is not USED, refer to *DMI Troubleshooting* on page 120.



For more information, see the **DMICONFIG** command, **RAWDMI** log and **INSUPDATESTATUS** log in the [OEM7 Commands and Logs Reference Manual](#).

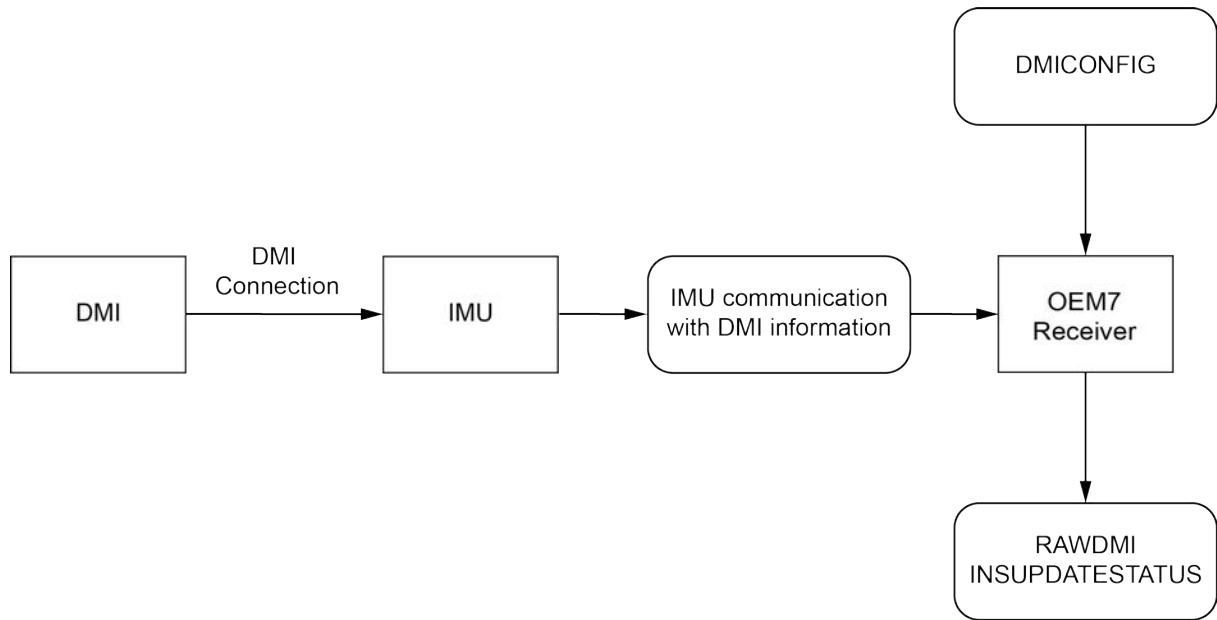
### 3.7.5 DMI Connected to an IMU

A DMI can be connected to the following IMUs:

- IMU-ISA-100C
- IMU-ENC-LN200
- IMU-HG1900
- IMU- $\mu$ IMU-IC
- IMU-IGM-A1
- IMU-IGM-S1
- IMU-FSAS
- IMU-CPT

*Figure 31: DMI to IMU Setup* on the next page shows an overview of a DMI connected to the IMU.

Figure 31: DMI to IMU Setup



### DMI Data Collected on IMU

Typical DMI hardware generates wheel ticks constantly as the wheel rotates. When a DMI is connected to the IMU, the wheel ticks are accumulated in the IMU. The accumulated wheel ticks, along with the raw IMU data, are sent the OEM7 receiver through the serial communication line.

### DMI Update Logic

DMI data is available through the **RAWDMI** log. The **RAWDMI** log can be used for applying DMI updates in post-processing.

The SPAN filter uses sequential **RAWDMI** logs to compute a distance traveled between update intervals (1 Hz). This information is used to constrain free inertial drift during times of poor GNSS visibility. The filter also contains a state for modeling the circumference of the wheel as it may change due to hardware changes or environmental conditions.

Information about how the DMI updates are being used is available in the **INSUPDATESTATUS** log.

### Connect the DMI to the IMU

All DMI compatible IMUs accept RS-422 differential signals from the DMI.



IMU-IGM-A1 and IMU-IGM-S1 accept TTL level input pulses from a DMI through the AUX connector.



The IMU-FSAS accepts signals from 2 V to 6 V.

To connect a DMI to the IMU:

1. Install the SPAN system using the instructions in *OEM7 Receiver Card Installation* on page 33 or *PwrPak7 Installation* on page 72.
2. Connect the wheel sensor to the IMU.

- a. For the IMU-ISA-100C, IMU-HG1900, IMU-ENC-LN200 or IMU- $\mu$ IMU-IC, use the IMU Enclosure Wheel Sensor cable (60723137), or a custom cable, to connect the DMI to the Wheel Sensor port on the IMU. See *IMU Enclosure Wheel Sensor Cable* on page 180 for information about the cable or for information about creating a custom wheel sensor cable.
- b. For the IMU-IGM-A1 or IMU-IGM-S1, use a custom cable to connect the DMI to the AUX port on the IMU. Refer to *IMU-IGM Ports* on page 164 for the pin out of the IMU-IGM AUX port.

The SPAN-IGM Auxiliary Port interface cable (01019015) can be used to connect the wheel sensor inputs to the IMU-IGM. However, when this cable is used with an IMU-IGM, only the wheel sensor inputs are available. The other connectors on this cable do not have connections to the IMU or receiver.

- c. For the IMU-FSAS or IMU-CPT, connect the DMI to the wheel sensor inputs on the IMU interface cable. Use the IMU-FSAS Cable with Wheel Sensor or a custom cable that provides access to the wheel sensor inputs. See the *IMU-FSAS Cable with Wheel Sensor* on page 153 for more information.
3. Connect an external power supply to the DMI.

The power required for the DMI depends on the DMI used. Refer to the DMI user documents for more information.

### Configure the DMI

1. Send the following command to enable a DMI on the IMU wheel sensor inputs.

```
DMICONFIG DMI1 ENABLE IMU
```

2. Send the following commands to log the DMI data.

```
LOG DMICONFIGA ONCHANGED
```

```
LOG RAWDMIA ONNEW
```

```
LOG INSUPDATESTATUSA ONNEW
```

3. Check the **RAWDMI** log to ensure the DMI is producing data.
4. Check the **INSUPDATESTATUS** log to ensure the DMI is being used in the SPAN solution.

If there is no DMI data being produced or the DMI status is not USED, refer to *DMI Troubleshooting* on page 120.

Refer to the [OEM7 Commands and Logs Reference Manual](#) for information about the commands and logs used in this section.

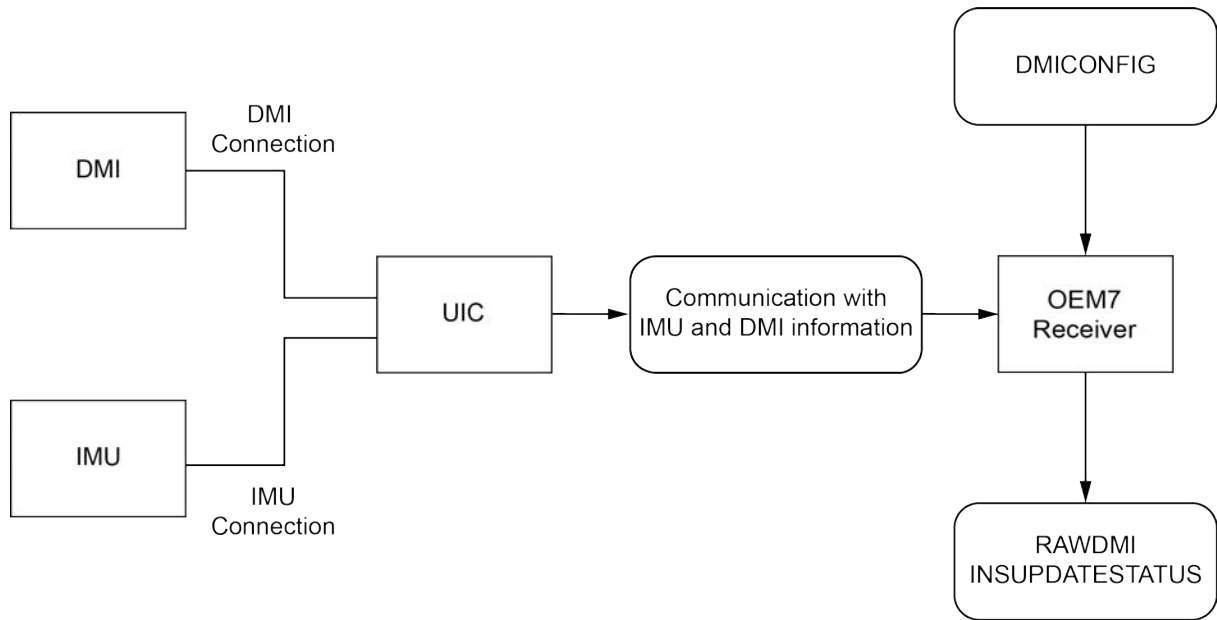
### 3.7.6 DMI Connected to a UIC

When a UIC is used to connect one of the following IMUs to an OEM7 receiver, the UIC can also be used to connect a DMI to the SPAN system.

- OEM-IMU-ISA-100C
- OEM-IMU-LN200
- OEM-IMU-HG1900
- OEM-IMU- $\mu$ IMU

*Figure 32: DMI to UIC Setup* on the next page shows an overview of a DMI connected to the UIC.

Figure 32: DMI to UIC Setup



### DMI Data Collected on UIC

Typical DMI hardware generates wheel ticks constantly as the wheel rotates. When a DMI is connected to the UIC, the wheel ticks are accumulated in the UIC. The accumulated wheel ticks, along with the raw data received from the IMU, are sent the OEM7 receiver through the serial communication line.

### DMI Update Logic

DMI data is available through the **RAWDMI** log. The **RAWDMI** log can be used for applying DMI updates in post-processing.

The SPAN filter uses sequential **RAWDMI** logs to compute a distance traveled between update intervals (1 Hz). This information is used to constrain free inertial drift during times of poor GNSS visibility. The filter also contains a state for modeling the circumference of the wheel as it may change due to hardware changes or environmental conditions.

Information about how the DMI updates are being used is available in the **INSUPDATESTATUS** log.

### Connect the DMI to the UIC

To connect a DMI to the UIC:

1. Install the SPAN system components using the instruction in *UIC Installation* on page 68.

When creating the UIC cabling, ensure the wheel sensor inputs on the UIC Receiver Communications Connector (J102) are brought out to a separate connector or wire bundle.

2. Connect the DMI to the UIC wiring harness.
3. Connect an external power supply to the DMI.

The power required for the DMI depends on the DMI used. Refer to the DMI user documents for more information.

## Configure the DMI

1. Send the following command to enable a DMI on the UIC wheel sensor inputs.

```
DMICONFIG DMI1 ENABLE IMU
```

2. Send the following commands to log the DMI data.

```
LOG DMICONFIGA ONCHANGED
```

```
LOG RAWDMIA ONNEW
```

```
LOG INSUPDATESTATUSA ONNEW
```

3. Check the **RAWDMI** log to ensure the DMI is producing data.
4. Check the **INSUPDATESTATUS** log to ensure the DMI is being used in the SPAN solution.

If there is no DMI data being produced or the DMI status is not USED, refer to *DMI Troubleshooting* on page 120.

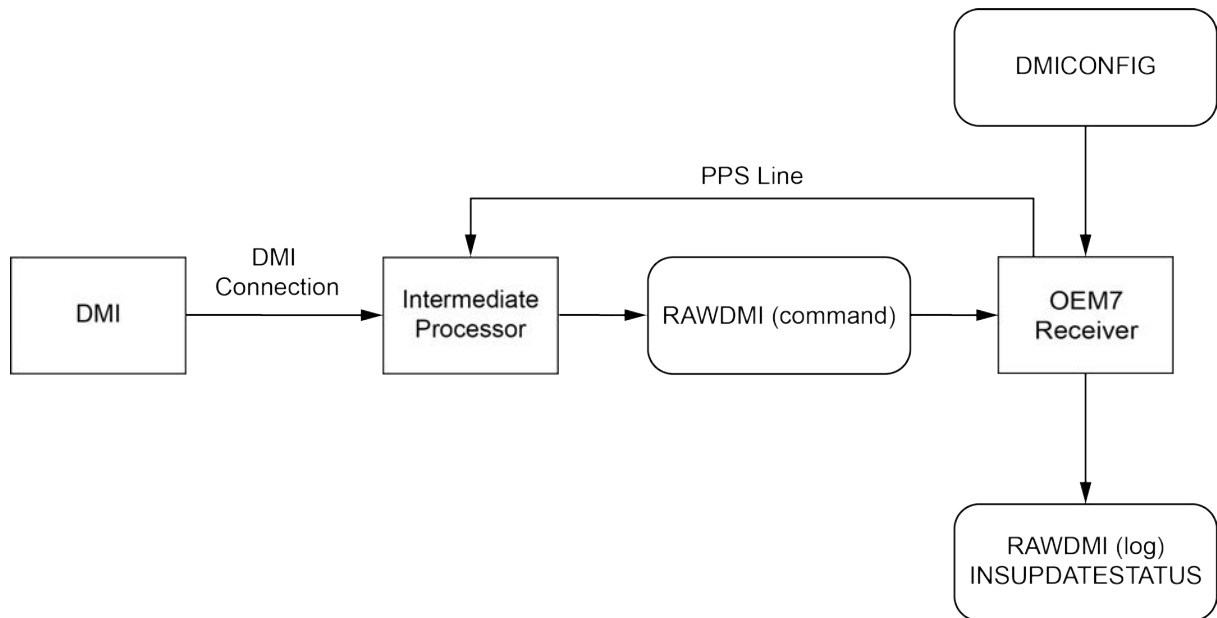
Refer to the [OEM7 Commands and Logs Reference Manual](#) for information about the commands and logs used in this section.

### 3.7.7 DMI Connected to an Intermediate Processor

NovAtel's OEM7 receiver cards do not handle DMI encoded signals natively. If using a receiver card, an intermediate processor is required to convert DMI pulses into NovAtel commands (RAWDMI).

Figure 33: *DMI through Intermediate Processor Setup* below shows an overview of a DMI connected to the receiver through an intermediate processor.

**Figure 33: DMI through Intermediate Processor Setup**



### DMI Data Collected using an Intermediate Processor

Typical DMI hardware generates wheel ticks constantly as the wheel rotates. When using an intermediate processor, the wheel ticks are sent to the processor. The processor either accumulates the wheel ticks or uses the DMI data to calculate the current velocity. The count or velocity data is sent to the OEM7 receiver through a serial communication line using the **RAWDMI** command. The **RAWDMI** command should be timed using the 1PPS output from the receiver.

## DMI Update Logic

DMI data is available through the **RAWDMI** log. The **RAWDMI** log can be used for applying DMI updates in post-processing.

The SPAN filter uses sequential **RAWDMI** logs to compute a distance traveled between update intervals (1 Hz). This information is used to constrain free inertial drift during times of poor GNSS visibility. The filter also contains a state for modeling the circumference of the wheel as it may change due to hardware changes or environmental conditions.

Information about how the DMI updates are being used is available in the **INSUPDATESTATUS** log.

## Connect the DMI to an Intermediate Processor

To connect a DMI:

1. Install the SPAN system components using the instructions in OEM7 Receiver Card Installation in the [OEM7 Installation and Operation User Manual](#).
2. Connect the DMI to the intermediate processor. Refer to the DMI and processor user documents for more information.
3. Connect the processor to one of the serial ports on the OEM7 receiver. Refer to Serial Ports in the [OEM7 Installation and Operation User Manual](#) for information about the receiver serial ports.
4. Connect the 1PPS signal from the OEM7 receiver to an input on the intermediate processor. Refer to EVENT\_IN, EVENT\_OUT and PPS Signal Protection in the [OEM7 Installation and Operation User Manual](#) for information about connecting the 1PPS signal.
5. Connect an external power supply to the DMI.

The power required for the DMI depends on the DMI used. Refer to the DMI user documents for more information.

## Configure the DMI

When using an intermediate processor, DMI data can be sent to the receiver as either accumulated wheel ticks or current velocity.

### Send Cumulative Wheel Ticks

The accumulated wheel ticks are sent from the intermediate processor to the OEM7 receiver using the **RAWDMI** command. This command must be sent once per update period (for example, once per second) and contain the number of wheel ticks accumulated during that update period. Sending of the **RAWDMI** command should be timed to the 1PPS signal from the receiver.

To configure the SPAN system to accept wheel ticks from an intermediate processor:

1. Send the following command to enable the DMI and set the expected input to wheel ticks.

```
DMICONFIG DMI1 ENABLE EXT_COUNT
```

2. Configure the intermediate processor to send a **RAWDMI** command to the OEM7 receiver once per update period. This command provides the number of wheel ticks accumulated during this update period.

In the following example, 1000 wheel ticks have been accumulated on DMI1.

```
RAWDMI 1000 0 0 0 1
```

3. Send the following commands to log the DMI data available in the receiver.

```
LOG DMICONFIGA ONCHANGED
```

```
LOG RAWDMIA ONNEW
```

```
LOG INSUPDATESTATUSA ONNEW
```

4. Check the **RAWDMI** log to ensure the DMI is producing data.
5. Check the **INSUPDATESTATUS** log to ensure the DMI is being used in the SPAN solution.

If there is no DMI data being produced or the DMI status is not USED, refer to *DMI Troubleshooting* on the next page.

For information about the commands and logs used in this procedure, refer to the [OEM7 Commands and Logs Reference Manual](#).

### Send Current Velocity

To send the current velocity to the OEM7 receiver, the intermediate processor must convert the DMI wheel ticks into a velocity. The velocity is then sent to the OEM7 receiver using the **RAWDMI** command. This command must be sent once per update period (for example, once per second) and contain the current velocity for that update period. Sending of the **RAWDMI** command should be timed to the 1PPS signal from the receiver.

To configure the SPAN system to accept wheel ticks from an intermediate processor:

1. Send the following command to enable a DMI on the UIC wheel sensor inputs.

```
DMICONFIG DMI1 ENABLE EXT_VELOCITY
```

2. Configure the intermediate processor to send a **RAWDMI** command to the OEM7 receiver once per update period. This command provides the current velocity for this update period.

Note, the **RAWDMI** value is a 32-bit signed integer representing the current velocity and should be scaled to the maximum precision per least significant bit (LSB). For example, if a velocity of 10 m/s is observed, and the precision of the measurement is to 0.01 m/s, then the measurement should be scaled by 100 (1/0.01) and the result would be an integer of 1000. The command for this example is:

```
RAWDMI 1000 0 0 0 1
```

In the same example, if a velocity of 10.01 m/s is observed, the resulting integer would be 1001.

```
RAWDMI 1001 0 0 0 1
```

3. Send the following commands to log the DMI data.

```
LOG DMICONFIGA ONCHANGED
```

```
LOG RAWDMIA ONNEW
```

```
LOG INSUPDATESTATUSA ONNEW
```

4. Check the **RAWDMI** log to ensure the DMI is producing data.
5. Check the **INSUPDATESTATUS** log to ensure the DMI is being used in the SPAN solution.

If there is no DMI data being produced or the DMI status is not USED, refer to *DMI Troubleshooting* on the next page.

For information about the commands and logs used in this procedure, refer to the [OEM7 Commands and Logs Reference Manual](#).

### 3.7.8 DMI Command Compatibility

With the introduction of the new streamlined command and log set for DMI use, legacy commands and logs have been deprecated.

Table 28: DMI Command and Log Compatibility

Firmware 7.06.xx and earlier	Type	Firmware 7.07.00 and later	Type
WHEELVELOCITY <sup>1</sup>	Command	RAWDMI	Log/Command
TIMEDWHEELDATA	Log	RAWDMI	Log/Command
WHEELSIZE	Log	None	
INSWHEELUPDATE	Command	None	
SETWHEELPARAMETERS	Command	DMICONFIG	Command
ENCLOSUREWHEELSENSOR	Command	DMICONFIG	Command

For firmware versions 7.06.xx and earlier, refer to [doc-s.novatel.com/OEM7/Content/Appendix/PreviousVersionsDocument.htm](https://doc.s.novatel.com/OEM7/Content/Appendix/PreviousVersionsDocument.htm) for information about the legacy commands and logs.

### 3.7.9 DMI Troubleshooting

Confirming that a DMI is setup and communicating properly within the entire system is important. Once all the hardware is setup, and the necessary commands have been issued, use the following checklist to ensure that the DMI information is being created and used:

- **RAWDMI** logs are being published by the receiver.
- **RAWDMI** logs have valid data (when in motion the value in the RAWDMI log will increase).
- DMISTATUS in the **INSUPDATESTATUS** log reports a status greater than or equal to ACTIVE.

If there are no valid **RAWDMI** logs being published from the receiver then debugging the hardware connections and setup commands may be required. Check the following:

- All communication lines are connected to the DMI.
- The DMI is being powered.
- The receiver is being powered.
- The DMI has been enabled through a **DMICONFIG** command.
- The receiver has the latest NovAtel Firmware, available from the NovAtel website ([novatel.com/support/support-materials/firmware-download](https://novatel.com/support/support-materials/firmware-download)).
- The receiver has a valid SPAN model for use with DMI.

Further electrical troubleshooting may be required to verify signal integrity. In many cases, note the following.

- Cable shields should be tied to the connector shells and the metallized backshells/housings should be in contact with the connector shells as well.
- A +/- and B +/- differential pairs should be on twisted pairs in the cables.

## 3.8 Azimuth Sources on a SPAN System

The SPAN system use three different methods to calculate the azimuth.

<sup>1</sup>The WHEELVELOCITY command will still be accepted in 7.07.00 with a limited capability. WHEELVELOCITY's cumulative tick field will be mapped to a RAWDMI command for backwards compatibility.



- Course Over Ground
- Inertial Azimuth
- ALIGN Azimuth

### 3.8.1 Course Over Ground

The course over ground azimuth is determined using the position delta between two position solutions computed by the OEM7 receiver. This is the simplest way to compute an azimuth and is done using either the GNSS solution or the INS solution. This method does not work when the vehicle is stationary as any position difference is due to position error and the computed azimuth is meaningless.

Course over ground azimuth is of greatest advantage in aerial or marine environments where the actual direction of travel may not match the forward axis of the aircraft/boat due to winds or currents. This effect is known as the crab angle. Course over ground azimuth is a great way to compute the offset if another means of computing the vehicle azimuth is available.

Course over ground azimuths are available in several different velocity logs. See *Table 29: Logs with Azimuth Data* below.

### 3.8.2 Inertial Azimuth

The inertial azimuth computed by the SPAN inertial navigation filter. It uses the sensors in the IMU to compute the azimuth of the IMU (this can be rotated to another reference if desired). For more information, see the **SETINSROTATION** command in the [OEM7 Commands and Logs Reference Manual](#).

This azimuth is the one provided in the majority of the INS logs available to a SPAN user. See *Table 29: Logs with Azimuth Data* below.

### 3.8.3 ALIGN Azimuth

On SPAN systems with dual antennas, an azimuth is available from the dual antenna baseline. This is the same azimuth that is used as an update to the SPAN solution. It is noisier than the inertial azimuth and is available at a much lower rate, but will have a stable mean. This azimuth is computed from the master antenna to the rover antenna based on how the antennas are oriented on the vehicle.

There is a specific subset of logs that output this azimuth. See *Table 29: Logs with Azimuth Data* below.

**Table 29: Logs with Azimuth Data**

Log	Log Format	Azimuth Source
BESTGNSSVEL	NovAtel	Course Over Ground From the best GNSS only solution
BESTVEL	NovAtel	Course Over Ground From the best system solution which could be either GNSS or INS
GPHDT	NMEA	ALIGN
GPVTG	NMEA	Course Over Ground From the best system solution which could be either GNSS or INS

Log	Log Format	Azimuth Source
HEADING2	NovAtel	ALIGN
INSATT / INSATTS / INSATTX	NovAtel	Inertial
INSPVA / INSPVAS / INSPVAX	NovAtel	Inertial
INSSPD	NovAtel	Course Over Ground Computed using the INS solution only
PASHR	NMEA	Inertial

### 3.9 Data Collection for Post Processing

Some operations, such as aerial measurement systems, do not require real-time information from SPAN. These operations are able to generate the position, velocity or attitude solution post-mission in order to generate a more robust and accurate solution than is possible in real-time.

In order to generate a solution in post-processing, data must be simultaneously collected at a base station and each rover. The following logs must be collected in order to successfully post process data.

From a base:

- RANGEB ONTIME 1
- RAWEPHEMB ONCHANGED
- GLOEPHEMERISB ONCHANGED (if using GLONASS)
- GALFNAVEPHEMERIS ONCHANGED (if using Galileo)
- GALINAVEPHEMERIS ONCHANGED (if using Galileo)
- BDSEPHMERIS ONCHANGED (if using BeiDou)
- QZSSEPHMERISB ONCHANGED (is using QZSS)

From a rover:

- RANGEB ONTIME 1
- RAWEPHEMB ONCHANGED
- GLOEPHEMERISB ONCHANGED (if using GLONASS)
- GALFNAVEPHEMERIS ONCHANGED (if using Galileo)
- GALINAVEPHEMERIS ONCHANGED (if using Galileo)
- BDSEPHMERIS ONCHANGED (if using BeiDou)
- QZSSEPHMERISB ONCHANGED (is using QZSS)
- INSCONFIGB ONCHANGED
- RAWIMUSXB ONNEW
- HEADING2B ONNEW (if using ALIGN dual antenna solution)
- RAWDMI ONNEW (if using a DMI sensor)

Post processing is performed using Waypoint Inertial Explorer. Visit our web site at [nova-tel.com/products/waypoint-software](http://nova-tel.com/products/waypoint-software) for details.



The highest rate that you should request GNSS logs (RANGE, BESTPOS, RTKPOS, PSRPOS, and so on) while in INS operation is 5 Hz. If the receiver is not running INS (no IMU is attached), GNSS logs can be requested at rates up to 20 Hz.

### 3.10 Firmware Updates and Model Upgrades

Firmware updates are firmware releases which include fixes and enhancements to the receiver functionality. Firmware updates are released on the web site as they become available.

Model upgrades enable features on the receiver and may be purchased through NovAtel authorized dealers.

Contact your local NovAtel dealer first for more information. To locate a dealer in your area visit Where to Buy | Dealer Network on the NovAtel web site at [novatel.com/contactus/sales-offices](http://novatel.com/contactus/sales-offices) or contact NovAtel Customer Support directly.

For information about how to install firmware updates or model upgrades, refer to the [OEM7 Installation and Operation User Manual](#).

### 3.11 Variable Lever Arm

The variable lever arm concept arose to support applications in which the IMU is no longer rigidly fixed to the vehicle, but rather on a gimballed mount. This creates an issue where the input lever arm offsets to the GNSS antenna are no longer correct, because the IMU can rotate on its mount, while the antenna remains fixed.

The use of the variable lever arm functionality requires that the device to which the IMU is attached be able to send its gimbal rotation angles back to SPAN. These angles are used to recalculate the lever arm at the rate that they are received. SPAN will also be able to output a gimballed solution at the rate the gimbal angles are received.

#### 3.11.1 Reference Frame Description

There are several frames of reference involved when dealing with a gimballed mount. The frames are all very similar, but can be quite confusing due to small differences. Below are all frames applicable to the implementation of the variable lever arm:

Frame	Description	Notation
IMU Body frame	The physical IMU axes	(b)
Vehicle frame	Default reference frame for attitude output in SPAN logs	(v)
Mount body frame	The physical axes of the gimballed mount	(m)
Gimbal body frame	The physical axes of the gimbal plane. This frame matches the mount body frame when gimbal angles are zero and rotates relative to the mount body frame when the gimbal is active.	(g)
User Output Frame	An arbitrary frame, used to define the desired reference for attitude output, typically matching a gimbal mounted sensor	(ou)
Mark Output Frame	An arbitrary frame, used to define the desired reference for attitude output for the MARKxPVA logs, typically matching a gimbal mounted sensor	(om)

Figure 34: Sample Configuration below and Figure 35: Operating Gimbal on the next page illustrate a basic scenario for the information in the table above. Figure 34: Sample Configuration shows a possible configuration for the mount body frame, IMU body frame and a user output frame, with the gimbal in a locked position. The extra rotation commands required to configure Variable Lever Arm for this setup are:

```
SETINSROTATION RBM 180 0 0
SETINSROTATION USER 0 0 90
SETINSROTATION RBV 0 0 -90
```

Figure 35: Operating Gimbal on the next page shows the gimbal in operation; the gimbal platform has moved relative to the mount body frame. The gimbal frame and IMU Body frame move together, as does the user output (or mark output) frame.

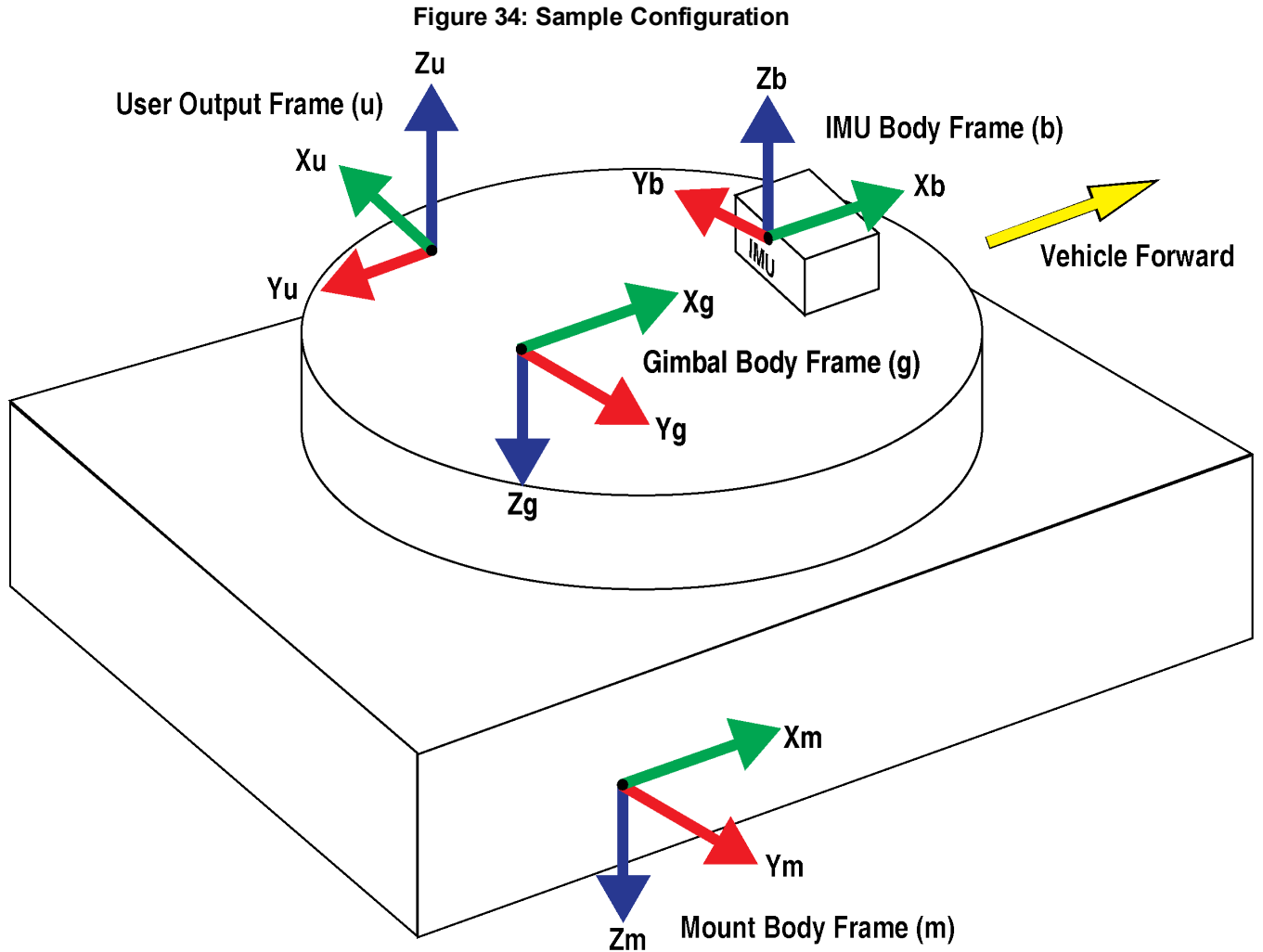
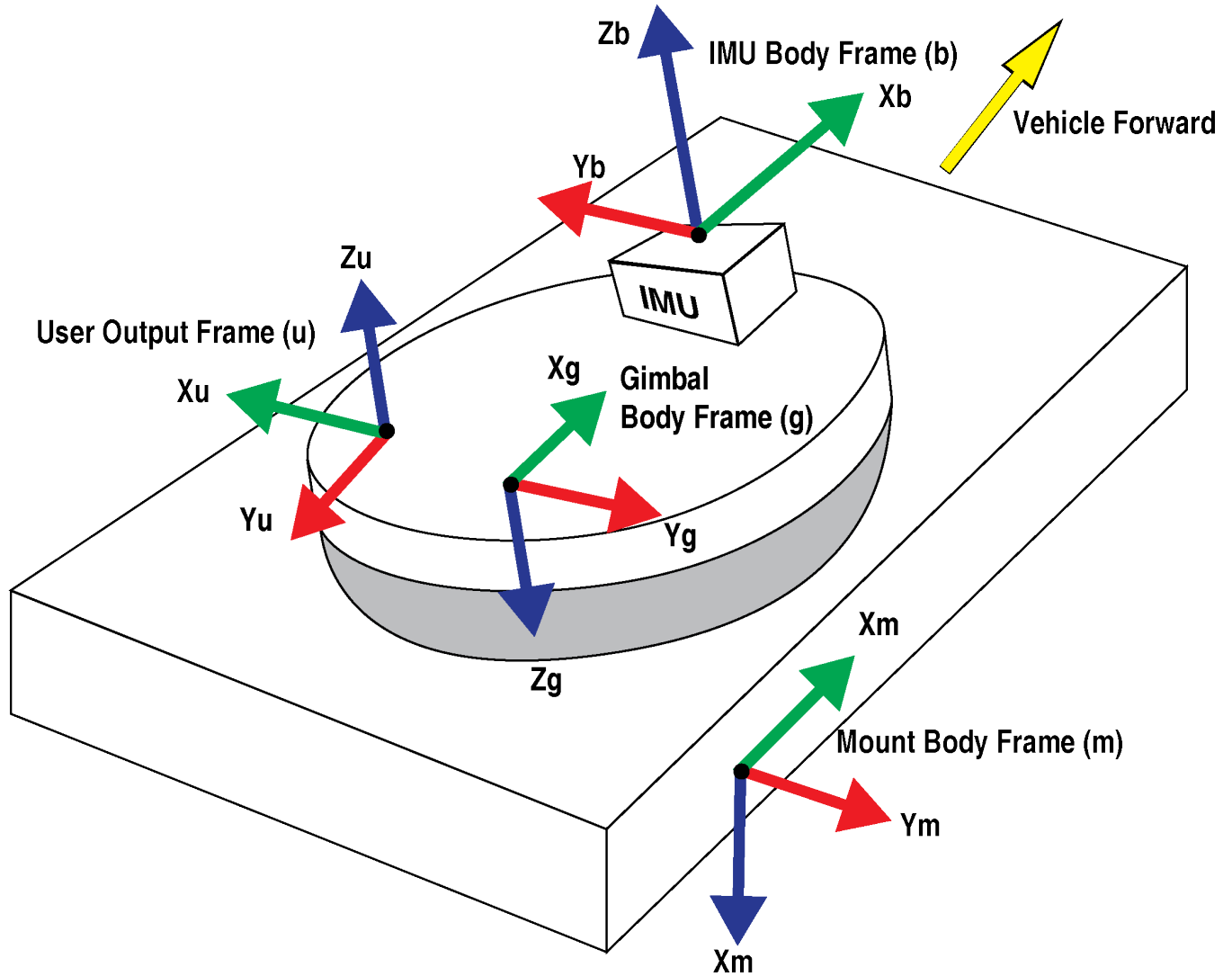


Figure 35: Operating Gimbal



### 3.11.2 How to Use Variable Lever Arm

The variable lever arm functionality is simple to use in a SPAN system. It requires the input of gimbal angles from the camera mount or platform that the IMU is mounted on. After that is provided, the system will automatically compute the variable lever arm and produce several messages for output.


Ensuring a proper variable lever arm is important for SPAN performance.

#### Basic I/O

The variable lever arm functionality is based on the input of the **INPUTGIMBALANGLE** command. This command specifies the right-handed rotation angles from the **mount body frame (m)** to the **gimbal body frame (g)**, with the order of rotations Z-X-Y. Entering this command will automatically cause the system to rotate the static lever arm into the latest gimballed frame. The update rate of the variable lever arm depends on the rate of the gimbal commands which can be entered at 1 to 50 Hz. If an **INPUTGIMBALANGLE** command is not received for over 1 second then the system will return to using the static lever arm.

In addition to using the variable lever arm internally, the following information is available to the user.

**Table 30: Logs used with Variable Lever Arm**

Log	Description
VARIABLELEVERARM	<p>This log displays the calculated variable lever arm.</p> <p>The VARIABLELEVERARM log is output in IMU Body frame.</p> <div style="border: 1px solid black; padding: 5px; margin-top: 10px;">  The <b>VARIABLELEVERARM</b> log will not be published or used internally unless a <b>SETINSROTATION RBM</b> command is sent. </div>
GIMBALLEDPVA	<p>This log has the same format as the INSPVA log, but contains the attitude rotated back to the null gimbal position. When the gimbal mount is in its zero locked position, the GIMBALLEDPVA attitude will match the attitude given in the INSPVA log. If the translational offset to the gimbal center of rotation has been provided, the position and velocity output are offset to this position. Otherwise, the position and velocity values are given at the IMU center of navigation.</p>
INSPVA, INSPVAS, INSPVAX	<p>The INSPVA log is synchronous so does not depend on the entry of the <b>INPUTGIMBALANGLE</b> command. However when the gimbal angles are non-zero, the INSPVA log no longer represents the orientation of the gimbal mount / vehicle, but rather the current orientation of the unlocked gimbal platform. If the orientation of the vehicle is important, use the GIMBALLEDPVA log.</p>

### Rotations and Translations

For the information provided by the system to be meaningful, the following offsets have to be set correctly. By default the system assumes that the IMU Body frame, gimbal mount and Mount Body frame are coincident. If this is not the case then additional commands are necessary to relate all of the different frames together using the commands below. If attitude output is desired relative to an external camera, this can also be configured using these commands.



When entering the SETINSROTATION commands described in the following table, the gimbal mount should be locked (INPUTGIMBALANGLE rotations are zero).

**Table 31: Commands used with Variable Lever Arm**

Command	Purpose
SETINSROTATION RBV	<p>This command provides the orientation of the IMU Body frame while the gimbal frame is in the locked null position. This is required information before the SPAN system can complete an inertial alignment. The <b>SETINSROTATION RBV</b> command relates the IMU Body frame (b) to the Vehicle frame (v).</p> <p>Once an RBV rotation has been provided, default attitude output will be referenced to the Vehicle frame.</p>
SETINSROTATION RBM	<p>This command relates the IMU Body frame (b) to the Mount Body frame (m). This information is required for interpreting the rotation angles from the <b>VARIABLELEVERARM</b> log correctly.</p>

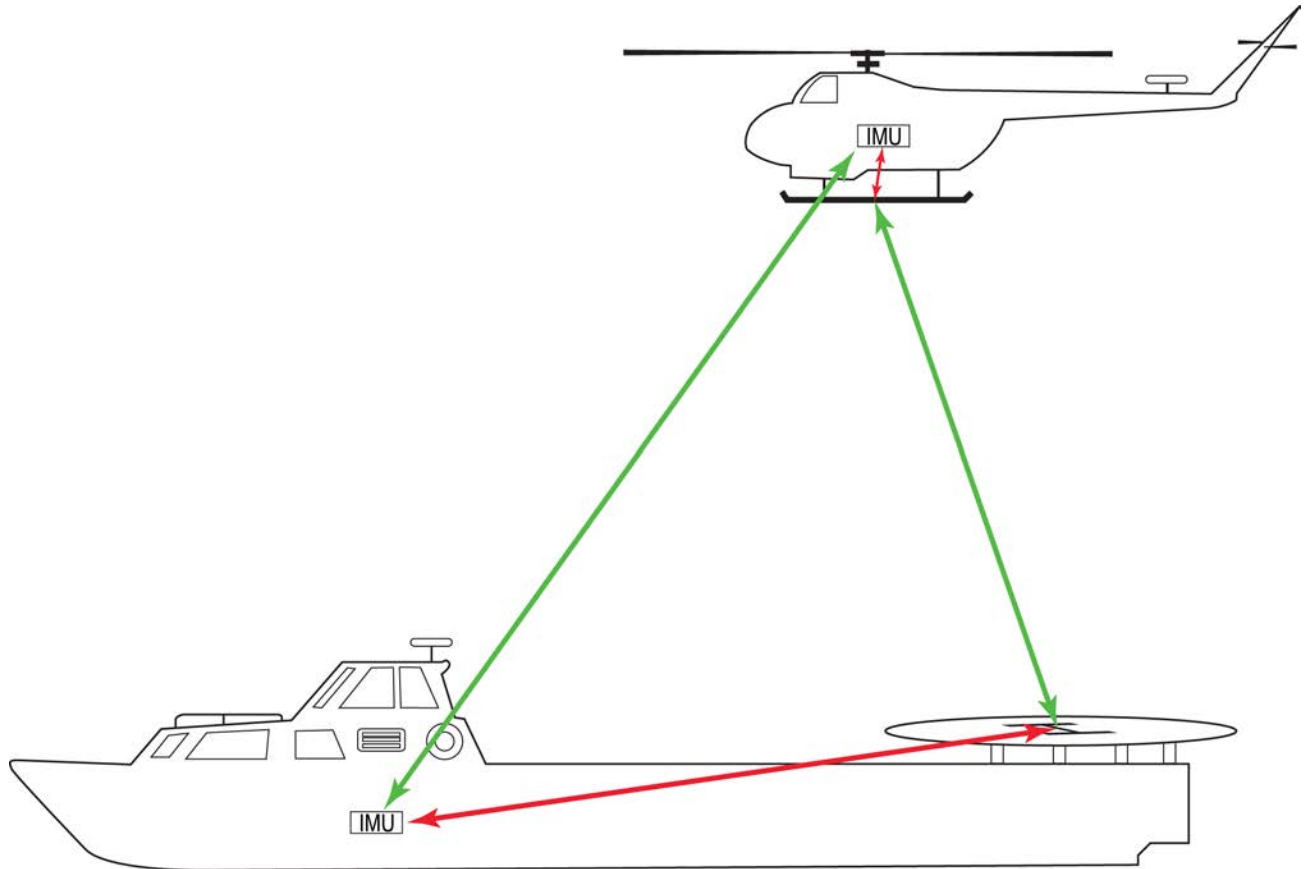
Command	Purpose
SETINSROTATION USER	By default, attitude information output by SPAN is for the vehicle frame. If attitude output is required to be referenced to another frame (typically the axes of a gimbal-mounted sensor), the USER offset can be used to rotate the attitude output in general SPAN logs to this frame.
SETINSROTATION MARKx	Similar to the user rotation, this rotation can be used to change the attitude output reference frame for the MARKxPVA logs.
SETINSTRANSALATION GIMBAL	This command provides the offset from the IMU center of navigation to the gimbal center of navigation. This is an optional translation used by Inertial Explorer for post-processing.

### 3.12 Relative INS

NovAtel's Relative INS technology generates a position, velocity and full attitude vector between two SPAN systems. One is the Master receiver and the other is the Rover receiver. Once configured, the Master receiver begins transmitting corrections to the Rover receiver. Relative information is created and the system begins filling the **RELINSPVA** log and **SYNCRELINSPVA** log on the Rover receiver. The **RELINSPVA** log is then transmitted back to the Master receiver for output.

The data link required must be able to support [864bits+108bits x #obs tracked per second]. The **RELINSPVA** log is requested ONNEW (available from 1Hz-20Hz depending on the setup of the **RELINSAUTOMATION** command) while the **SYNCRELINSPVA** log can be requested ONTIME at up to 200Hz (at the rover only). Position and velocity solutions are differenced in the ECEF frame and then rotated into the local level. The Relative offset vector that is output is dependent on Master/Rover's precise RTK vector and their eccentric offset vectors (optional offset provided using the **USER** parameter in the **SETINSTRANSALATION** command), shown in *Figure 36: Relative INS Example* on the next page.

Figure 36: Relative INS Example



An important command that can be used with Relative INS to manually change the maximum amount of time to use RTK data is the **RTKTIMEOUT** command. This command is used to set the maximum age of RTK data to use when operating as a rover station. RTK data received that is older than the specified time is ignored. The default is 60 seconds, however when using Relative INS, it is suggested this be set to 5 seconds by sending the command **RTKTIMEOUT 5**.



For information about the **RTKTIMEOUT** command, refer to the [OEM7 Commands and Logs Reference Manual](#).

### 3.12.1 Configure Relative INS

To configure the receivers to begin computing the relative information:

1. Setup a link between the receivers that will be used to transfer data (for example, radios).
2. Enable the transfer of relative corrections between receivers using one of the methods below.
  - Send the **RELINSAUTOMATION** command only at the Rover receiver
  - Send the **RELINSCONFIG** command at both the Master and Rover receiver



To configure Relative INS using the **RELINSAUTOMATION** command, the master and rover receivers must be communicating using a COM port. If the master and rover are communicating via an ICOM port, the **RELINSCONFIG** command must be used.





The Model option must be present on both the rover and master for the Relative INS feature to be enabled.



The master and rover receiver must be using the same datum.

## Chapter 4 SPAN with Dual Antenna

NovAtel's ALIGN heading technology generates distance and bearing information between a “master” and one or more “rover” receivers.

SPAN with Dual Antenna provides the hardware necessary to run an ALIGN baseline with an IMU and a second receiver.

With SPAN, the ALIGN GNSS baseline can be used to assist the initial alignment of the SPAN solution. In addition, the ALIGN baseline solution will aid the heading solution from the receiver if the heading drifts due to slow or constant dynamics.

ALIGN is capable of a 10 Hz heading output rate when integrated with the OEM7 receiver.



For optimal SPAN performance when using Dual Antenna with SPAN, an ALIGN offset calibration is required for each unique installation. This calibration refines the IMU to antenna baseline angular offset from the initial estimate derived from the input lever arms. Refer to the **INSCALIBRATE** command for details.

### 4.1 Installation

The hardware for SPAN with Dual Antenna is installed in a manner similar to other SPAN systems. Some points to consider during your installation are:

1. Install the IMU and the two antennas in the vehicle such that the relative distance between them is fixed.
2. The antennas should be mounted as a similar height, relative to the IMU, where the view of the satellites will not be obstructed by any part of the vehicle. As heading accuracy is dependent on baseline length, mount the antennas as far apart as possible. A minimum separation distance of 1 meter is recommended.
3. The lever arms or distance from the IMU to the antennas needs to be fixed and accurately measured using the coordinate axes defined on the outside of the IMU. The baseline between the two antennas does NOT need to be aligned with the vehicle axes or with the axes of the IMU.
4. Both receivers need to be powered and connected to each other via COM 2 before sending any configuration commands. It does not matter which receiver is powered on first, or how long they are both powered before sending any commands.



SPAN with Dual Antenna operation assumes the use of the COM 2 port for communication between receivers unless a different port is specified using the **INSALIGNCONFIG** command. This command can change the COM ports of the SPAN-enabled master and the rover, the baud rate used and data output rates.



For information about connecting the ALIGN master and rover receivers using a port that is not a serial COM port (e.g. Ethernet), contact NovAtel Customer Support.

The two receivers need to be set up as shown in the example in *Figure 37: SPAN - Two Receiver Dual Antenna Installation* on the next page.

Dual antenna receivers, such as the OEM7720 and PwrPak7D, contain the hardware necessary to provide an ALIGN solution without an additional receiver. Set up a SPAN system with a dual antenna receiver as shown in *Figure 38: SPAN - Single Receiver Dual Antenna Installation* on the next page.

**Figure 37: SPAN - Two Receiver Dual Antenna Installation**

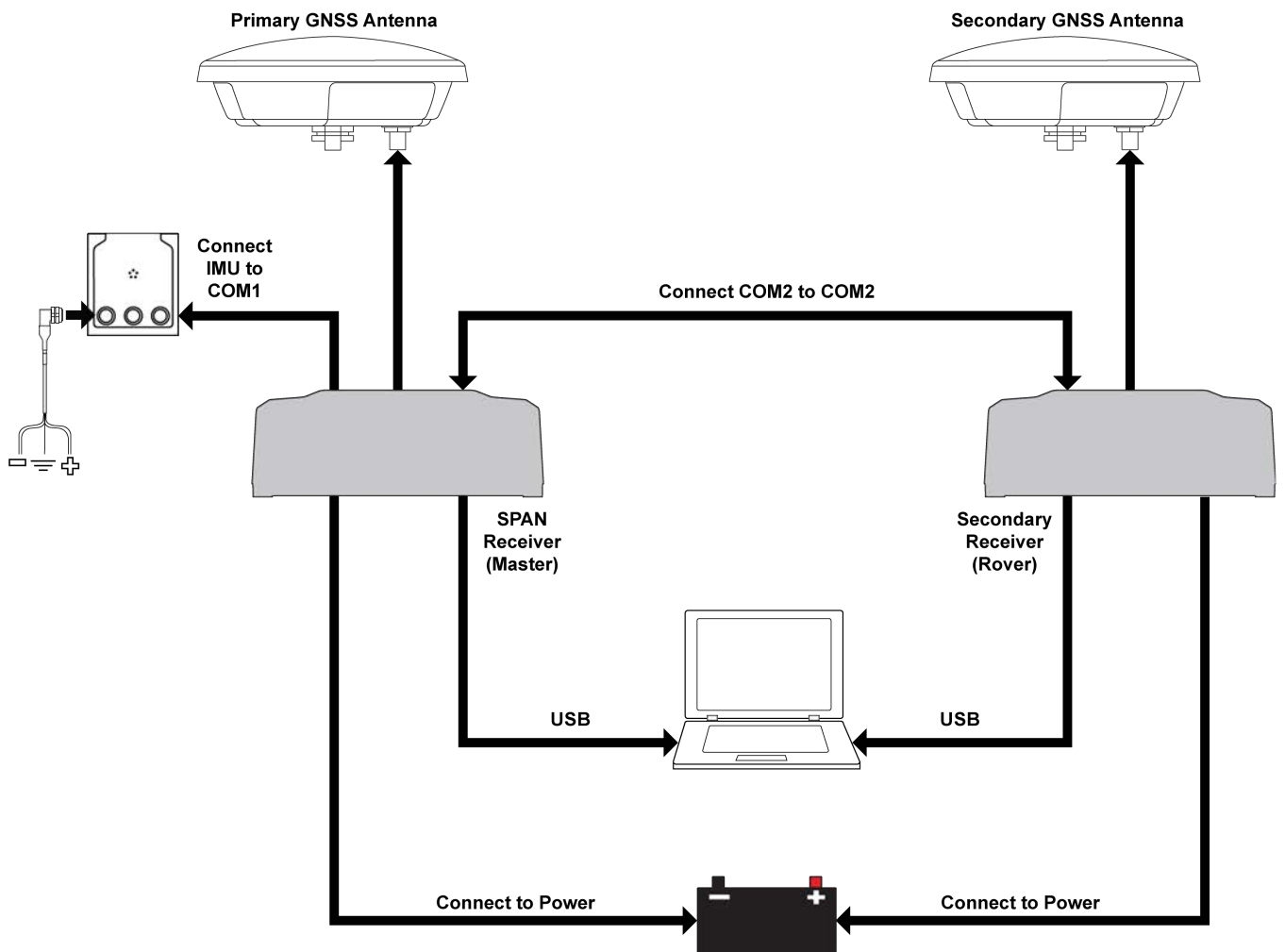
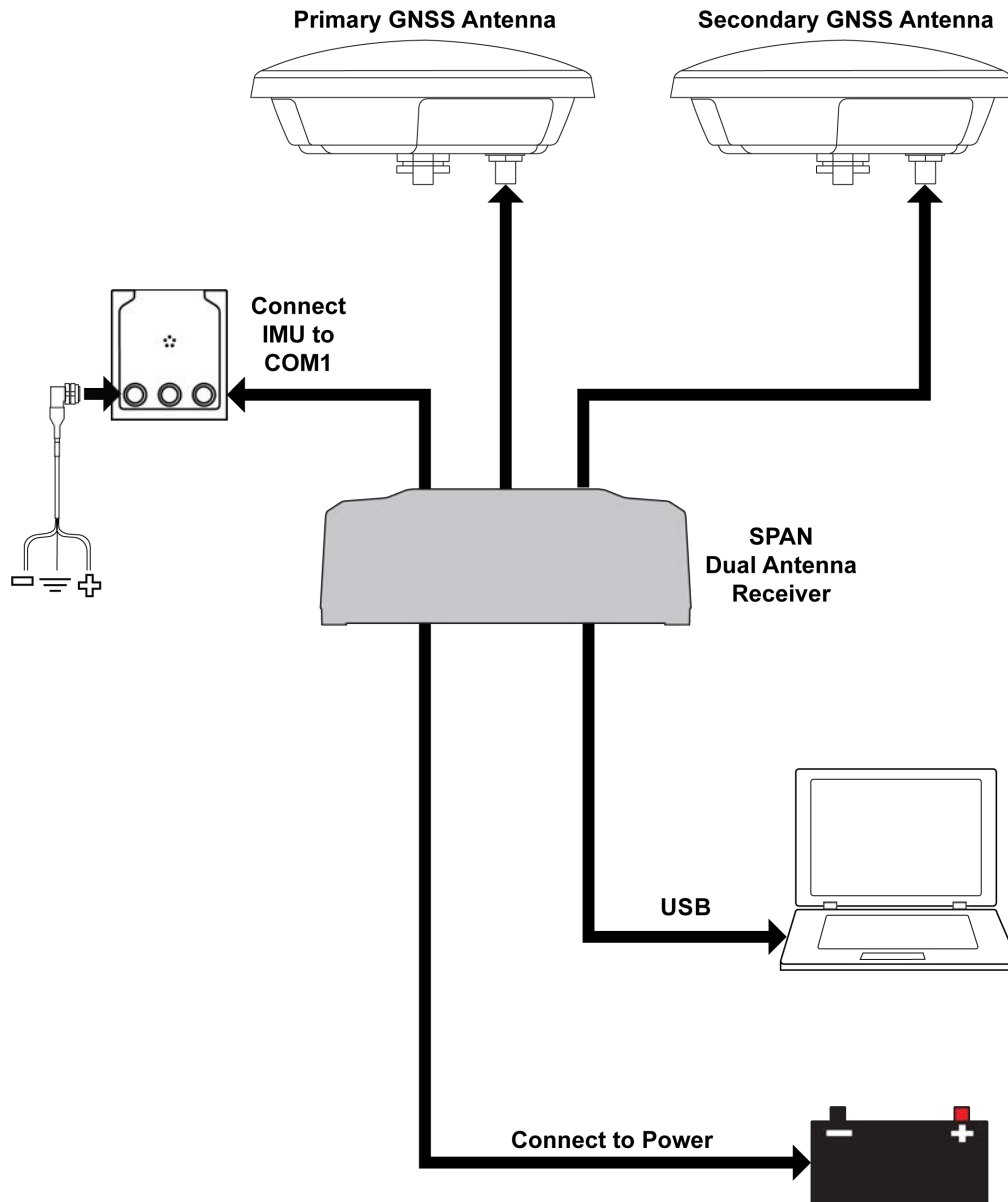


Figure 38: SPAN - Single Receiver Dual Antenna Installation



## 4.2 Configuring ALIGN with SPAN

Before configuring the ALIGN solution, the two receivers should both be powered on and connected directly between COM 2 of the SPAN receiver and COM 2 of the second receiver through either a null modem cable or an appropriate radio connection. For dual antenna receivers, such as the OEM7720 and PwrPak7D, the receiver must be powered on.



COM2 is the default COM port for ALIGN. If the default COM ports are changed using the **INSALIGNCONFIG** command, connect the COM ports that are specified by the **INSALIGNCONFIG** command.



The rover receiver must be an ALIGN-capable model.

To enable the dual-antenna ALIGN solution to aid the INS alignment and provide heading updates, the offset between the antennas and the IMU must be known. This is achieved by entering lever arms to both antennas, using the **SETINSTRANSULATION** command.

To configure SPAN with ALIGN Aiding:

1. Enter the lever arm from the IMU to the primary antenna.

Abbreviated ASCII example:

```
SETINSTRANSULATION ANT1 0.54 0.32 1.20 0.03 0.03 0.05
```

2. Enter the lever arm from the IMU to the secondary antenna.

Abbreviated ASCII example:

```
SETINSTRANSULATION ANT2 0.54 2.32 1.20 0.03 0.03 0.05
```

Alternately, the angular offset between the dual-antenna baseline (from primary GNSS antenna to secondary GNSS antenna) and the IMU frame forward axis is entered directly via the **ALIGN** parameter of the **SETINSROTATION** command.



We recommend entering the lever arms rather than entering the angular offset as this is easier to measure and will lead to better overall accuracy.

Refer to the [OEM7 Commands and Logs Reference Manual](#) for the syntax of the above commands.

As with all ALIGN-capable products, the GNSS baseline solution is available from the **GPHDT** log and **HEADING2** log. For INS heading, use the **INSATT** log or **INSPVA** log.

The SPAN system can be configured for different alignment routines depending on the motion conditions experienced during the alignment period. The different alignment routines are described in *Configuring SPAN with ALIGN* below.

### 4.3 Configuring SPAN with ALIGN

The SPAN receiver can be configured for different alignment routines depending on the motion conditions experienced during the alignment period. For example, in marine applications, the dynamics required for either a coarse or kinematic alignment cannot be guaranteed, so a different alignment routine will be required.



Before the ALIGN heading can be computed and used by SPAN, both GNSS antennas must have a clear view of the sky.



For optimal SPAN performance when using Dual Antenna with SPAN, an ALIGN offset calibration is required for each unique installation. This calibration refines the IMU to antenna baseline angular offset from the initial estimate derived from the input lever arms. Refer to **INSCALIBRATE** command for details.

The different alignment routines are described in the following sections:

### 4.3.1 Aided Transfer Alignment – ALIGN Injected Azimuth

This alignment routine is the preferred dual antenna alignment method. It is used if the alignment mode is set to AIDED\_TRANSFER using the **ALIGNMENTMODE** command, and can be used if the alignment mode is set to AUTOMATIC.

If your vehicle is not stationary during the alignment, such as may be the case on a ship, use the Aided Transfer Alignment routine. This alignment method uses the ALIGN baseline solution to perform an instantaneous alignment of the vehicle azimuth.

The alignment happens instantaneously after the receiver establishes communication with the IMU and computes a verified, fixed integer, ALIGN solution.

To guarantee the use of this alignment mode, the **ALIGNMENTMODE** command must be sent to the receiver:

```
ALIGNMENTMODE AIDED_TRANSFER
```

### 4.3.2 Unaided Alignment

The unaided alignment sets the SPAN system to use only single antenna alignment options (static, kinematic or manual alignment).

To use this alignment mode, the **ALIGNMENTMODE** command must be sent to the receiver.

```
ALIGNMENTMODE UNAIDED
```

### 4.3.3 Automatic Alignment Mode – Automatic Alignment (default)

Automatic Alignment Mode Selection is the default setting for a SPAN receiver. This mode is designed to allow alignment of the system as quickly as possible, using either an aided transfer alignment (*Aided Transfer Alignment – ALIGN Injected Azimuth* above); a kinematic alignment (*Kinematic Alignment* on page 97); or a manual alignment (*Manual Alignment* on page 98).

The first available technique will be used, regardless of its relative quality. If you wish to guarantee a specific technique is used, or use an aided static alignment, you must select the desired alignment mode manually. No additional configuration is required to use this alignment routine.

## 4.4 SPAN ALIGN Attitude Updates

The INS heading updates are used to help constrain the azimuth drift of the INS solution whenever possible. This is of the greatest value with lower-quality IMUs and in environments with low dynamics where the attitude error is less observable. Slow moving marine or train applications are good examples of the intended use. By providing an external heading source, the solution drift can be constrained in these environments.

You can monitor the heading update status as outlined in the **INSUPDATESTATUS** log in the [OEM7 Commands and Logs Reference Manual](#).

## APPENDIX A IMU Technical Specifications

The following appendices detail the technical specifications of the SPAN compatible IMUs.

- *HG1700 IMU (single-connector enclosure)* on the next page
- *IMU-CPT* on page 141
- *IMU-FSAS* on page 148
- *IMU-HG1900* on page 156
- *IMU-IGM* on page 161
- *IMU-ISA-100C* on page 170
- *IMU-KVH1750* on page 182
- *IMU-ENC-LN200* on page 191
- *IMU- $\mu$ IMU-IC* on page 196
- *LN-200 IMU (single-connector enclosure)* on page 201
- *OEM-IMU-ADIS-16488* on page 206
- *OEM-IMU-EG320N* on page 214
- *OEM-IMU-HG4930* on page 224
- *OEM-IMU-ISA-100C* on page 228
- *OEM-IMU-STIM300* on page 235
- *OEM-IMU- $\mu$ IMU* on page 243
- *Universal IMU Enclosure (HG1700, LN200)* on page 249
- *MIC - MEMS Interface Card* on page 259
- *UIC - Universal IMU Controller* on page 272

For technical specifications for the SPAN compatible receivers and the PwrPak7-E1, see the [OEM7 Installation and Operation User Manual](#) or [PwrPak7 Installation and Operation User Manual](#).

## A.1 HG1700 IMU (single-connector enclosure)

Table 32: HG1700 IMU Physical Specifications

Physical	
IMU Enclosure Size	193 mm x 167 mm x 100 mm (7.6" x 6.6" x 3.9")
IMU Size	160 mm x 160 mm x 100 mm (6.3" x 6.3" x 3.9")
IMU + Enclosure Weight	3.4 kg (7.49 lb.)

See the following sections for more information about the HG1700 IMU.

- *HG1700 IMU Mechanical Drawings* on the next page
- *HG1700 IMU Performance* on page 139
- *HG1700 Electrical and Environmental* on page 140
- *Interface Cable for the HG1700 IMU* on page 140

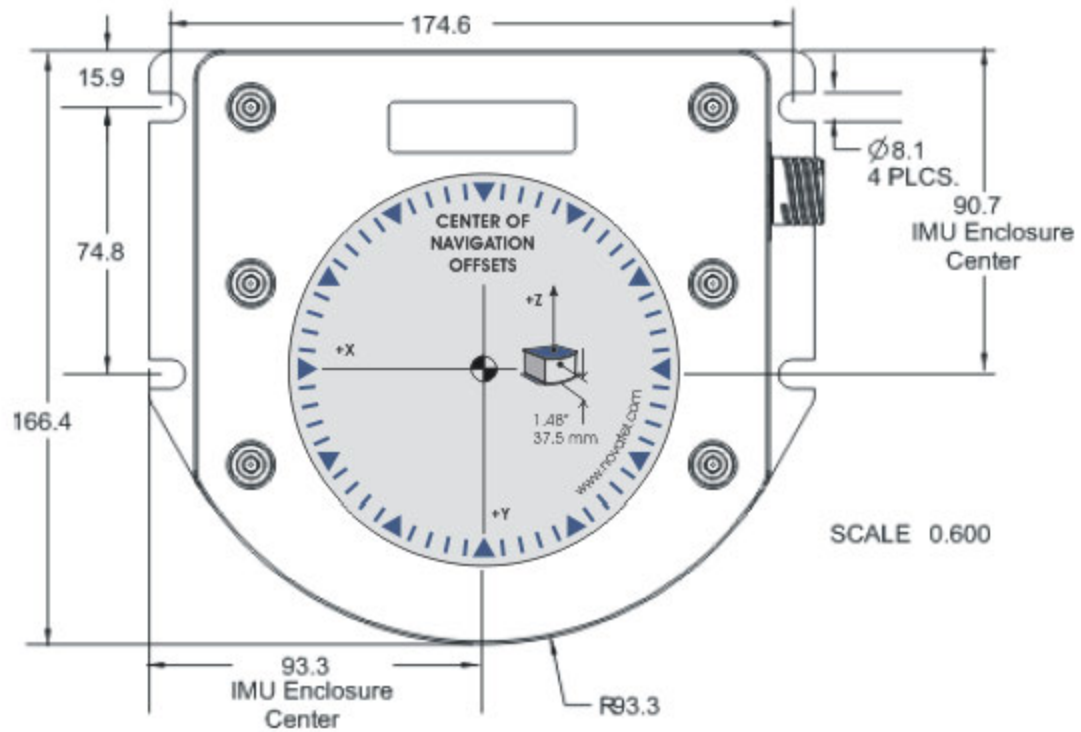


### A.1.1 HG1700 IMU Mechanical Drawings

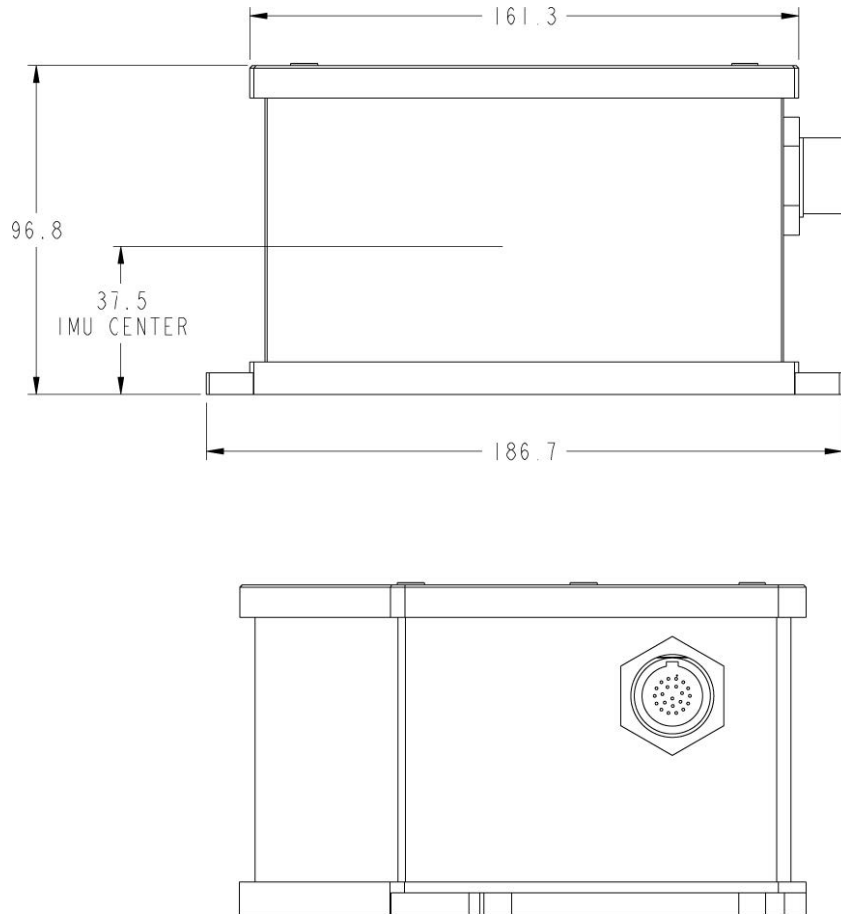


The dimensions in the following diagrams are in millimeters.

Figure 39: HG1700 Top/Bottom Dimensions



**Figure 40: HG1700 Enclosure Side Dimensions**



The center of Navigation, shown on the HG1700 label, for the internal IMU is the same as the enclosure center. The enclosure center measurements are labeled as IMU Enclosure Center in these figures.

**A.1.2 HG1700 IMU Performance****Table 33: HG1700-AG58 IMU Performance**

<b>Gyroscope Performance</b>	
Gyro Input Range	$\pm 1000$ °/second
Gyro Rate Bias	1.0 °/hour
Gyro Rate Scale Factor	150 ppm
Angular Random Walk	0.125 °/ $\sqrt{\text{hour}}$
<b>Accelerometer Performance</b>	
Accelerometer Range	$\pm 50$ g
Accelerometer Linearity	500 ppm
Accelerometer Scale Factor	300 ppm
Accelerometer Bias	1.0 mg
<b>Data Rate</b>	
IMU Measurement	100 Hz

**Table 34: HG1700-AG62 IMU Performance**

<b>Gyroscope Performance</b>	
Gyro Input Range	$\pm 1000$ °/second
Gyro Rate Bias	5.0 °/hour
Gyro Rate Scale Factor	150 ppm
Angular Random Walk	0.5 °/ $\sqrt{\text{hour}}$
<b>Accelerometer Performance</b>	
Accelerometer Range	$\pm 50$ g
Accelerometer Linearity	500 ppm
Accelerometer Scale Factor	300 ppm
Accelerometer Bias	2.0 mg
<b>Data Rate</b>	
IMU Measurement	100 Hz

### A.1.3 HG1700 Electrical and Environmental

**Table 35: HG17000 Electrical Specifications**

Electrical	
IMU Power Consumption	IMU-H58: 9 W (max) IMU-H62: 8 W (max)
IMU Input Voltage	+12 to +28 VDC
Receiver Power Consumption	1.8 W (typical)
System Power Consumption	13.8 W (typical)
Input/Output Connectors	MIL-C-38999-III, 22 pin (all IMUs)
IMU Interface	RS-232 or RS-422

**Table 36: HG17000 Environmental Specifications**

Environmental (IMU)	
Operating Temperature	-30°C to +60°C (-22°F to 140°F)
Storage Temperature	-45°C to +80°C (-49°F to 176°F)
Humidity	95% non-condensing

#### A.1.4 Interface Cable for the HG1700 IMU

The IMU interface cable provides power to the IMU from an external power source and enables communication between the receiver and IMU. The HG1700 IMU uses the Universal IMU Enclosure Interface cable (see *Universal IMU Enclosure Interface Cable* on page 257).

## A.2 IMU-CPT

**Table 37: IMU-CPT Physical Specifications**

Physical	
IMU Size	168 mm W X 152 mm L X 89 mm H
IMU Weight	2.29 kg

See the following sections for more information about the IMU-CPT.

- *IMU-CPT Mechanical Drawings* on the next page
- *IMU-CPT Sensor Specifications* on page 144
- *IMU-CPT Electrical and Environmental* on page 145
- *IMU-CPT Cable* on page 146

**A.2.1 IMU-CPT Mechanical Drawings**



The dimensions in the following diagrams are in inches and millimeters (in square brackets).

**Figure 41: IMU-CPT Side and Perspective View**

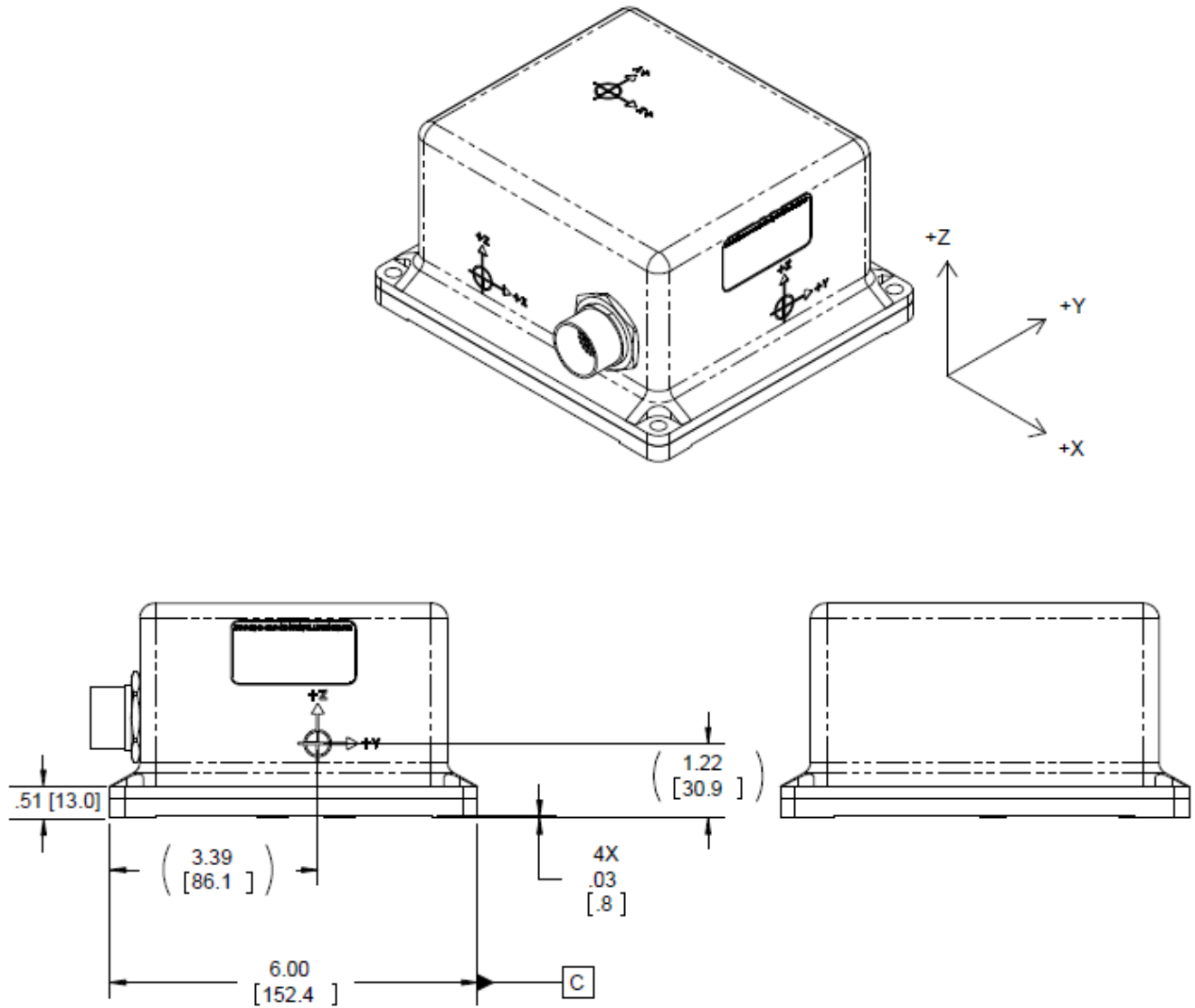
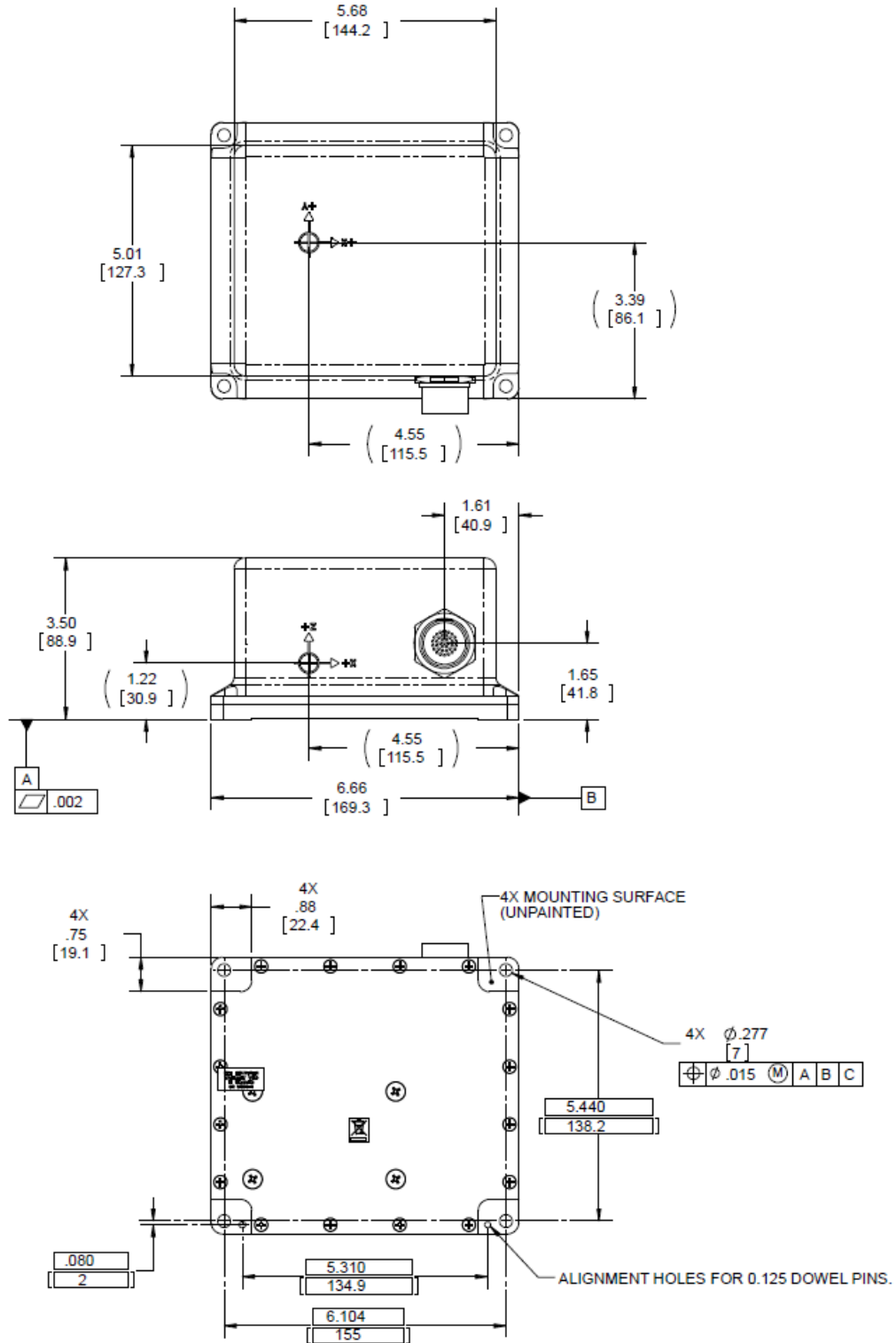


Figure 42: IMU-CPT Top, Front and Bottom View



## A.2.2 IMU-CPT Sensor Specifications

Table 38: IMU-CPT Performance

Gyroscope Performance	
Bias Offset	$\pm 20$ °/hour
Turn On To Turn On Bias Repeatability (Compensated)	$\pm 3$ °/hour
In Run Bias Variation, At Constant Temperature	1 °/hour @ $1\sigma$
Scale Factor Error (Total)	1500 ppm, $1\sigma$
Scale Factor Linearity	1000 ppm, $1\sigma$
Temperature Dependent SF Variation	500 ppm, $1\sigma$
Angular Random Walk	$0.0667$ °/ $\sqrt{\text{hour}}$ @ $1\sigma$
Maximum Input	$\pm 375$ °/second
Accelerometer Performance	
Bias Offset	$\pm 50$ mg
Turn On To Turn On Bias Repeatability	$\pm 0.75$ mg
In Run Bias Variation, At Constant Temperature	0.25 mg @ $1\sigma$
Temperature Dependent Bias Variation	0.5 mg/°C @ $1\sigma$
Scale Factor Error (Total)	4000 ppm, $1\sigma$
Temperature Dependent SF Variation	1000 ppm, $1\sigma$
Accelerometer Noise	$55$ $\mu\text{g}/\sqrt{\text{Hz}}$ @ $1\sigma$
Bandwidth	50 Hz
Accelerometer Bias	$\pm 10$ g
Data Rate	
IMU Measurement	100 Hz



**A.2.3 IMU-CPT Electrical and Environmental****Table 39: IMU-CPT Electrical Specifications**

<b>Electrical</b>	
Input Power	9 - 18 VDC
Power Consumption	13 W (max)
Power and I/O Connector	MIL-DTL-38999 Series 3
Start-Up Time (Valid Data)	< 5 seconds

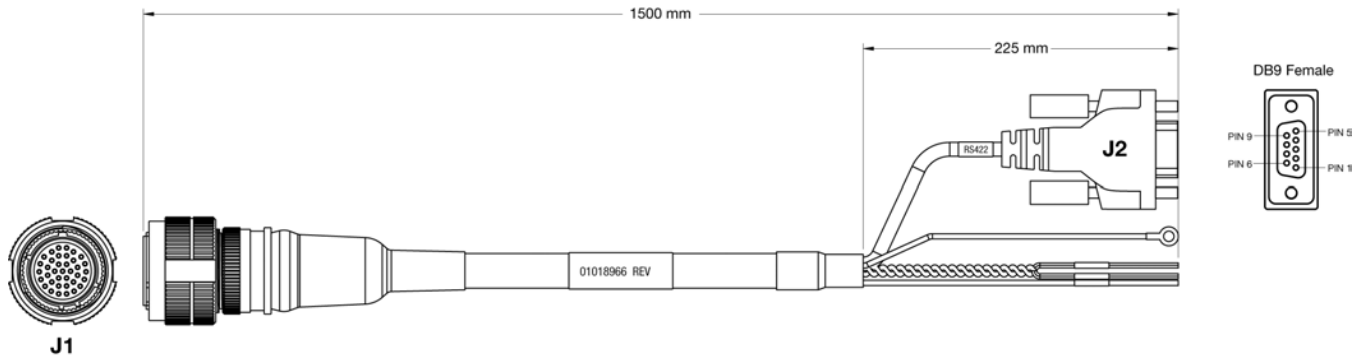
**Table 40: IMU-CPT Environmental Specifications**

<b>Environmental</b>	
Temperature, operational	-40°C to +65°C
Temperature, non-operational	-50°C to +80°C
Vibration, operational	6 g rms, 20 Hz -2 KHz
Vibration, non-operational	8 g rms, 20 Hz -2 KHz
Shock, operational	7g 6-10 msec, 1/2 sine
Shock, non-operational	60 g 6-10 msec, 1/2 sine
Altitude	-1000 to 50,000 ft.
Humidity	95% at 35°C, 48 hrs
MTBF	≥ 10,500 hours

### A.2.4 IMU-CPT Cable

The NovAtel part number for the IMU-CPT cable is 01018966. This cable provides power to the IMU from an external power source and enables communication between the receiver and the IMU.

**Figure 43: IMU-CPT Development Terminated Cable**



**Table 41: IMU-CPT Connector Pinout Descriptions**

J1 Pin #	Function	J2 (Female DB9) Pin #	Bare Connectors
1	Power Return		Labeled Pin 1
2	9-16 VDC Power Input		Labeled Pin 2
3-20	Reserved		
21	IMU RS422 TX+	2	
22	IMU RS422 TX-	8	
23-24	Reserved		
25	IMU RS422 Signal Ground	5	
26-34	Reserved		
35	TOV Out	9	
36	External Clock Input	1	
37	Chassis GND		Labeled Pin 37
	Chassis GND		Ring lug

#### Custom Cable Recommendations

The tables below provide recommendations for creating custom cables to replace the IMU-CPT cable (01018966).

**Table 42: Connectors**

Connector	Description
J1	MIL-DTL 38999, 37 connector, plug
J2	DB-9, female

**Table 43: Maximum  
Cable Length**

IMU	RS-422
IMU-CPT	< 1.5 meters

## A.3 IMU-FSAS

**Table 44: IMU-FSAS Physical Specifications**

Physical	
IMU Size	128 mm x 128 mm x 98 mm (5.04" x 5.04" x 3.86")
IMU Weight	2.1 kg (4.63 lb.)

See the following sections for more information about the IMU-FSAS.

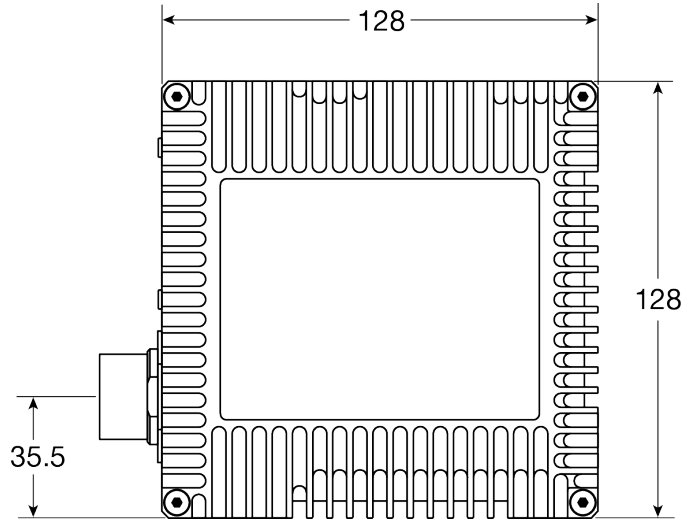
- *IMU-FSAS Mechanical Drawings* on the next page
- *IMU-FSAS Performance* on page 152
- *IMU-FSAS Electrical and Environmental* on page 152
- *Interface Cable for IMU-FSAS* on page 153
- *IMU-FSAS Cable with Wheel Sensor* on page 153

### A.3.1 IMU-FSAS Mechanical Drawings



The dimensions in the following diagrams are in millimeters.

**Figure 44: IMU-FSAS Top Dimensions**



**Figure 45: IMU-FSAS Bottom Dimensions**

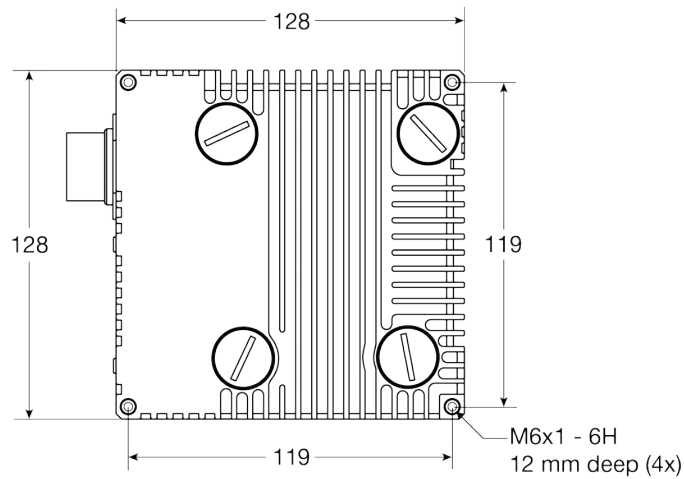


Figure 46: IMU-FSAS Side Dimensions

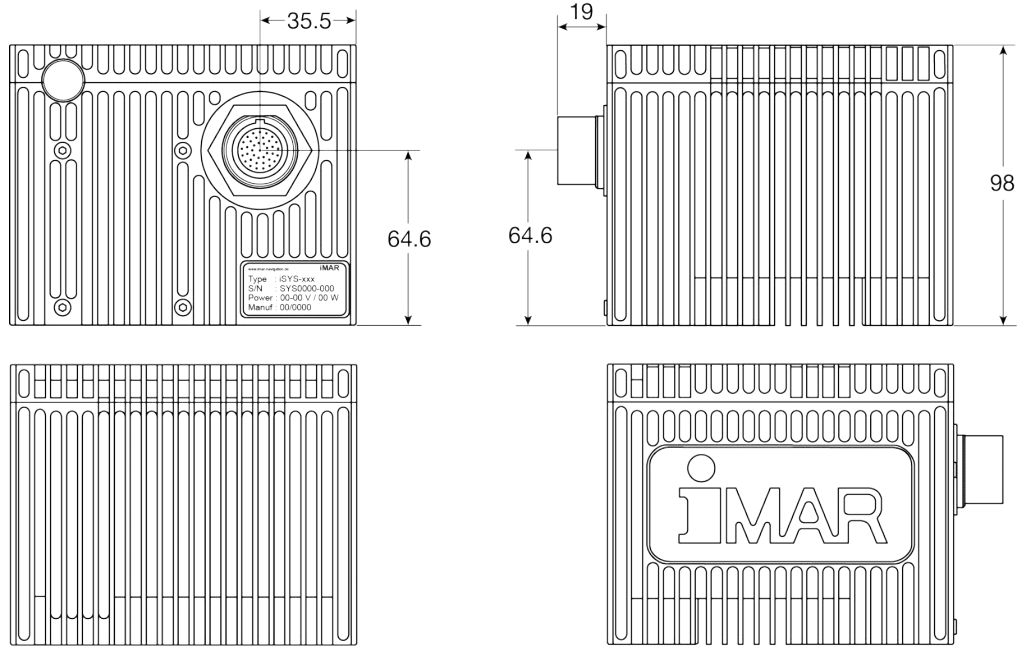
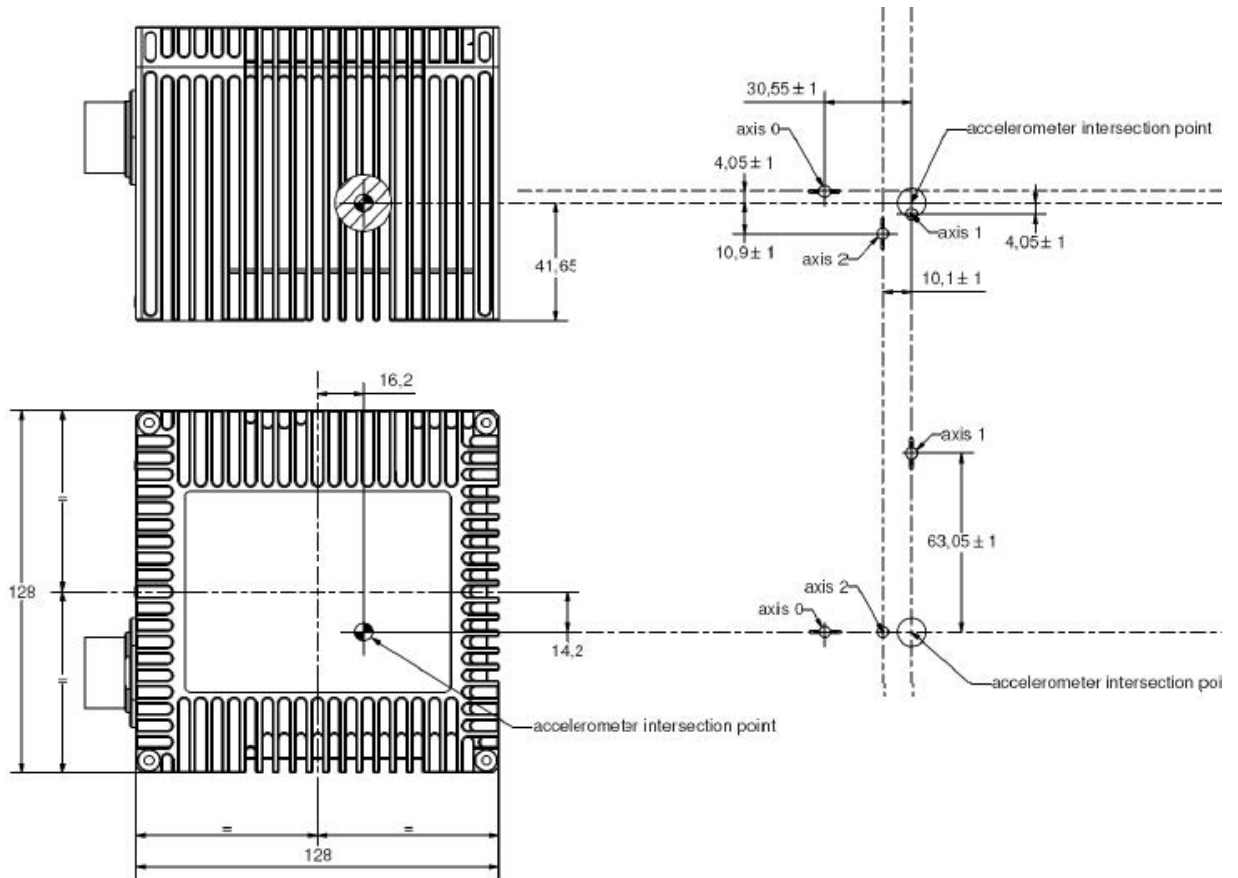


Figure 47: IMU-FSAS Center of Navigation



**A.3.2 IMU-FSAS Performance****Table 45: IMU-FSAS Performance**

<b>Gyroscope Performance</b>	
Gyro Input Range	±450 °/second
Gyro Rate Bias	<0.75°/hour
Gyro Rate Scale Factor	300 ppm
Angular Random Walk	0.1 °/√hour
<b>Accelerometer Performance</b>	
Accelerometer Range	±5 g (±20 g optional)
Accelerometer Scale Factor	300 ppm
Accelerometer Bias	1.0 mg
<b>Data Rate</b>	
IMU Measurement	200 Hz

**A.3.3 IMU-FSAS Electrical and Environmental****Table 46: IMU-FSAS Electrical Specifications**

<b>Electrical</b>	
IMU Power Consumption	16 W (max)
IMU Input Voltage	+10 to +34 VDC
Receiver Power Consumption	1.8 W (typical)
System Power Consumption	13.8 W (typical)
Input/Output Connectors	MIL-C-38999-III
IMU Interface	RS-422

**Table 47: IMU-FSAS Environmental Specifications**

<b>Environmental</b>	
Operating Temperature	-40°C to +71°C (-40°F to 160°F)
Storage Temperature	-40°C to +85°C (-40°F to 185°F)
Humidity	95% non-condensing



### A.3.4 Interface Cable for IMU-FSAS

The IMU interface cable can be one of the following cables:

Cable	NovAtel Part Number	Comment	For more information
Universal IMU Enclosure Interface cable	01018977	For standard pinout enclosures.	See <i>Universal IMU Enclosure Interface Cable</i> on page 257
IMU-FSAS cable with Wheel Sensor	01018388	For standard pinout enclosures. Includes an additional connector for wheel sensor cabling.	See <i>IMU-FSAS Cable with Wheel Sensor</i> below

### A.3.5 IMU-FSAS Cable with Wheel Sensor

The NovAtel part number for the IMU-FSAS cable with Wheel Sensor is 01018388 (see *Figure 48: IMU-FSAS Interface Cable with Wheel Sensor* below). This cable:

- provides power to the IMU from an external power source
- enables input and output between the receiver and the IMU
- enables input from an optional Wheel Sensor

See also *DMI Connected to an IMU* on page 113.

**Figure 48: IMU-FSAS Interface Cable with Wheel Sensor**

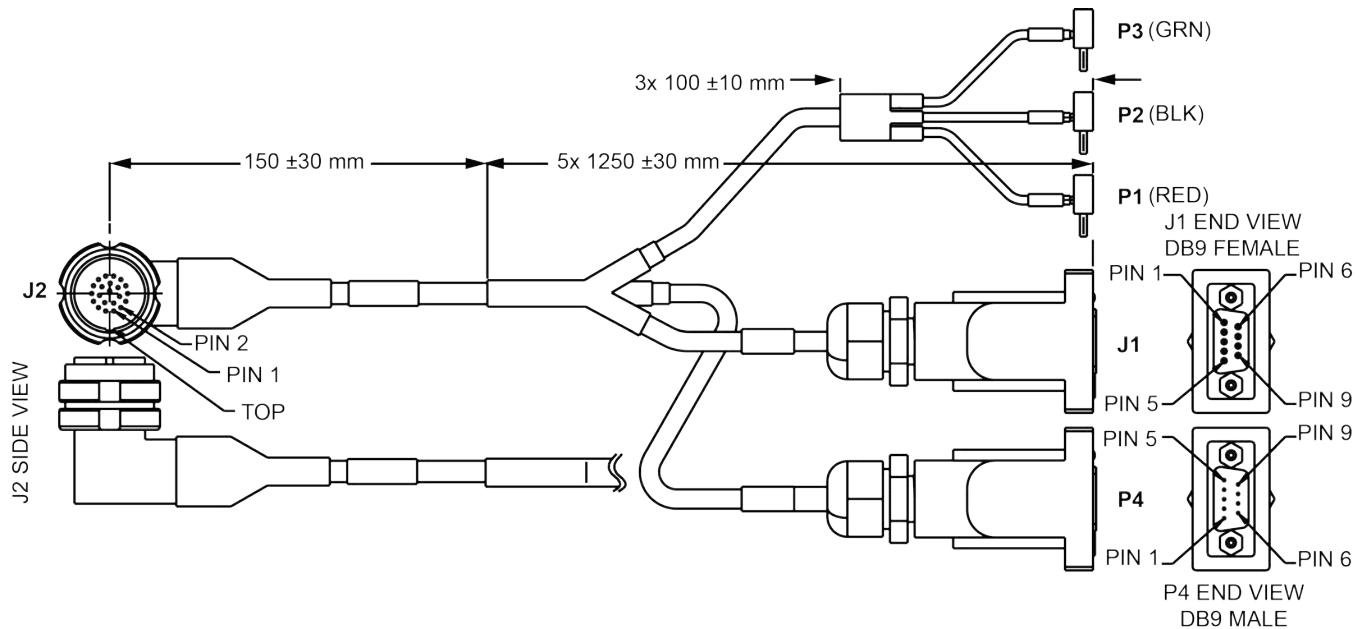


Table 48: IMU-FSAS Cable with Wheel Sensor Pinout

MIL-C-38999 III Connector Pin	Function	Power 4 mm plugs	J1 Female DB9	P4 Male DB9	Comments
1	Vin(-)	Color: black Label: Vin (-)			Power ground
22	Vin(-)				
2	ODO_AN			7	Wheel sensor input A(-), opto-coupler: +2 to +6 V (RS-422 compatible)
4	ODO_A			6	Wheel sensor input A(+), opto-coupler: +2 to +6 V (RS-422 compatible)
3	Vin(+)	Color: red Label: Vin(+)			+10 to +34 VDC
21	Vin(+)				
5	Not used				
6	Not used				
7	DAS(+)		1		Shielded data acquisition signal (LVCMOS to VARF)
9	DAS GN (-)		5		Shielded ground reference for data acquisition and control signals
8	Reserved				
10	Reserved				
11	OEM_CTS/ Rx-		8		Twisted pair; serial data output signal / RS-422(-)
12	OEM_Rx/ Rx+		2		Twisted pair; serial data output signal / RS-422(+)
13	Reserved				
14	DGND		5		Digital ground
15	DGND		5		Digital ground
16	ODO_B			3	Wheel sensor input B(+), opto-coupler: +2 to +6 V (RS-422 compatible)
17	ODO_BN			1	Wheel sensor input B(-), opto-coupler: +2 to +6 V (RS-422 compatible)
18	Reserved				

MIL-C-38999 III Connector Pin	Function	Power 4 mm plugs	J1 Female DB9	P4 Male DB9	Comments
19	OEM_Tx/ Tx+		3		Twisted pair; serial data in / RS-422 (+)
20	OEM_RTS/ Tx		7		Twisted pair; serial data in / RS-422 (-)

### Custom Cable Recommendations

The tables below provide recommendations for creating custom cables to replace the IMU-FSAS cable with Wheel Sensor (01018388).

**Table 49: Connectors**

Connector	Description
J1	DB-9, female
J2	MIL-DTL-38999 III, plug
P4	DB-9, male

**Table 50: Maximum Cable Length**

IMU	RS-422
iIMU-FSAS	< 1.5 meters

## A.4 IMU-HG1900

The IMU-HG1900 contains a Honeywell HG1900 IMU.

**Table 51: IMU-HG1900 Physical Specifications**

Physical	
IMU Enclosure Size	130 mm x 130 mm x 125 mm
IMU Enclosure Weight	2.5 kg

See the following sections for more information about the IMU-HG1900.

- *IMU-HG1900 Mechanical Drawings* on the next page
- *IMU-HG1900 Sensor Specifications* on page 159
- *IMU-HG1900 Electrical and Environmental* on page 160
- *IMU-HG1900 Cables* on page 160

**A.4.1 IMU-HG1900 Mechanical Drawings**



The dimensions in the following diagrams are in millimeters.

**Figure 49: IMU-HG1900 Dimensions**

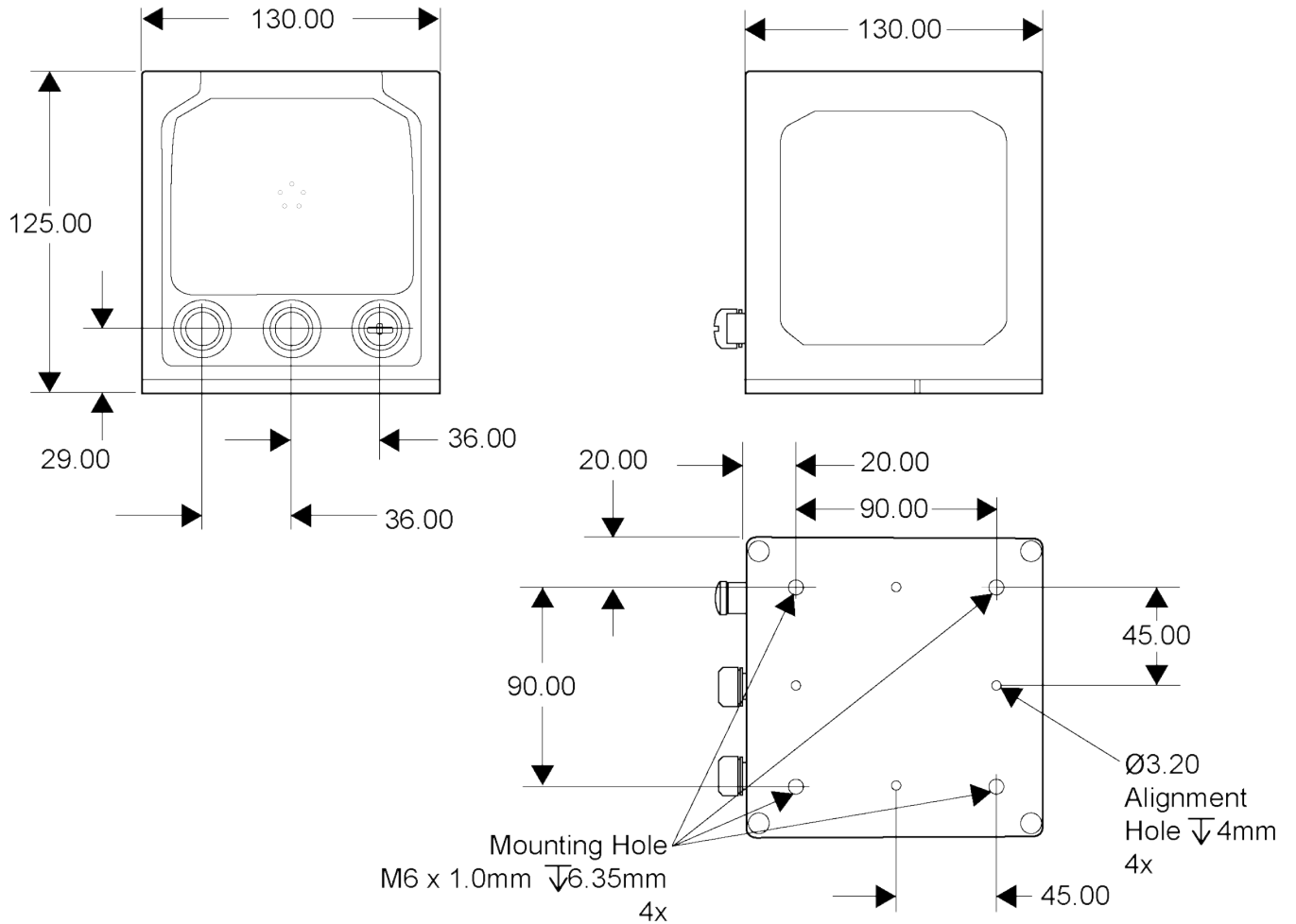
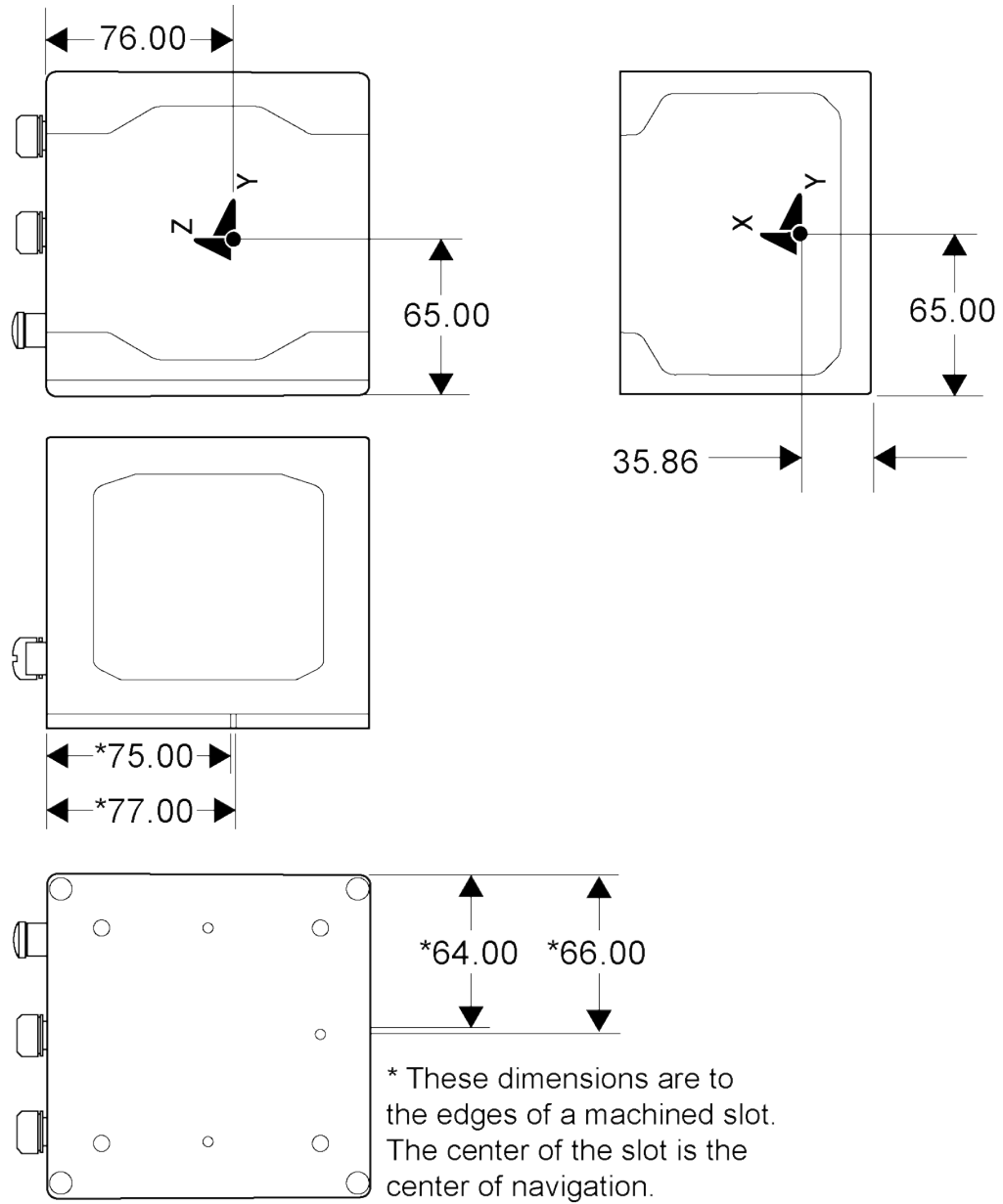


Figure 50: IMU-HG1900 Center of Navigation



### A.4.2 IMU-HG1900 Sensor Specifications

**Table 52: IMU-HG1900 IMU Performance**

<b>Gyroscope Performance</b>	
Input range	$\pm 1000$ °/second
Rate bias	5 °/hour
In-run bias stability	1 °/hour
Rate Scale factor	150 ppm
Angular random walk	0.09 °/ $\sqrt{\text{hour}}$
<b>Accelerometer Performance</b>	
Range	$\pm 30$ g
Linearity	500 ppm
Scale factor	300 ppm
Bias repeatability	1 mg
Bias in-run stability	0.7 mg
<b>Data Rate</b>	
IMU Measurement	100 Hz

### A.4.3 IMU-HG1900 Electrical and Environmental

**Table 53: IMU-HG1900 Electrical Specifications**

Electrical	
IMU Power Consumption	7.5 W (typical)
IMU Input Voltage	+10 to +34 VDC
IMU Interface	RS-422
Connectors	
Power	SAL M12, 5 pin, male
Data	SAL M12, 5 pin, female
Wheel Sensor	SAL M12, 8 pin, male

**Table 54: IMU-HG1900 Environmental Specifications**

Environmental	
Operating Temperature	-40°C to +55°C
Storage Temperature	-40°C to +80°C
Humidity	MIL-STD-810G(Ch1), Method 507.6
Random Vibe	MIL-STD-810G(Ch1), Method 514.7 (2.0 g)
Environment	MIL-STD-810G(Ch1), Method 512.6 IEC 60529 IP67

#### A.4.4 IMU-HG1900 Cables

##### IMU-HG1900 Interface Cable

The IMU-HG1900 uses the IMU Enclosure Interface Cable. Refer to *IMU Enclosure Interface Cable* on page 177 for details about this cable.

##### IMU-HG1900 Power Cable

The IMU-HG1900 uses the IMU Enclosure Power Cable. Refer to *IMU Enclosure Power Cable* on page 179 for details about this cable.

##### IMU-HG1900 Wheel Sensor Cable

The IMU-HG1900 uses the IMU Enclosure Wheel Sensor Cable. Refer to *IMU Enclosure Wheel Sensor Cable* on page 180 for details about this cable.



## A.5 IMU-IGM

This section contains the specifications for both the IMU-IGM-A1 and IMU-IGM-S1.

**Table 55: IMU-IGM-A1 Physical Specifications**

Physical	
Enclosure Size	152.0 mm x 137.0 mm x 50.5 mm
Weight	475 g
Connectors	
MAIN	DB-15HD Female
AUX	DB-15HD Male

**Table 56: IMU-IGM-S1 Physical Specifications**

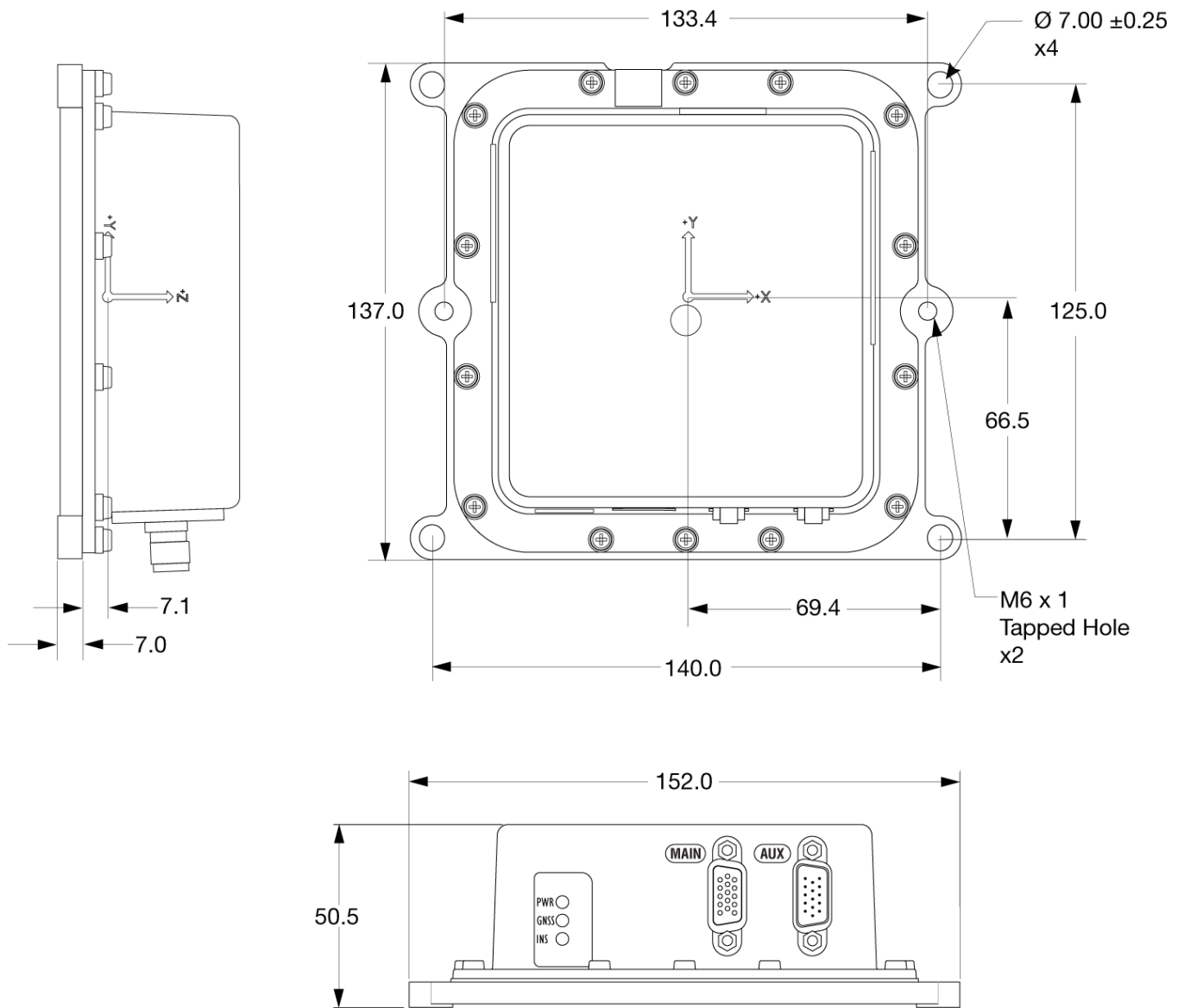
Physical	
Enclosure Size	152.0 mm x 137.0 mm x 50.5 mm
Weight	500 g
Connectors	
MAIN	DB-15HD Female
AUX	DB-15HD Male

See the following sections for more information about the IMU-IGM-A1 or IMU-IGM-S1 IMUs.

- *IMU-IGM Mechanical Drawings* on the next page
- *IMU-IGM Ports* on page 164
- *IMU-IGM Sensor Specifications* on page 166
- *IMU-IGM Electrical and Environmental* on page 167
- *IMU-IGM Interface Cable* on page 168

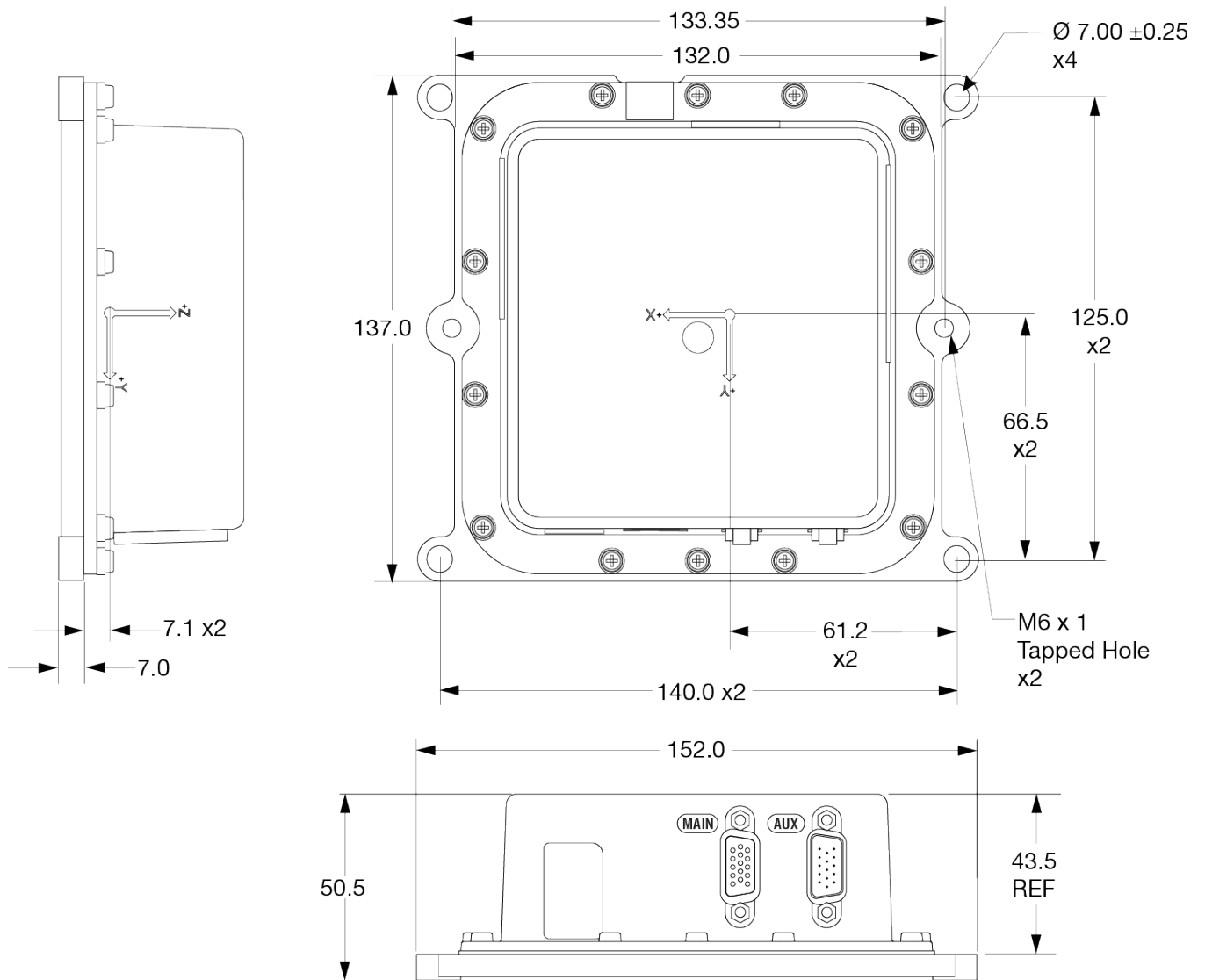
**A.5.1 IMU-IGM Mechanical Drawings**

**Figure 51: IMU-IGM-A1 Dimensions**



The center of navigation is at the location marked by the axis labels on the enclosure and indicated on the drawing above. It is not at the depression in the enclosure cover. The dimensions in the drawing are in millimeters.

**Figure 52: IMU-IGM-S1 Dimensions**



The center of navigation is at the location marked by the axis labels on the enclosure and indicated on the drawing above. It is not at the depression in the enclosure cover. The dimensions in the drawing are in millimeters.

## A.5.2 IMU-IGM Ports

**Table 57: IMU-IGM Main Port Pinout**

Pin #	Label	Description
1	MIC_TX/MIC_TX+	MODE2 open: MIC port transmit (RS-232) MODE2 low: MIC port transmit positive (RS-422)
2	MIC_TX-	MODE2 open: No connection MODE2 low: MIC port transmit negative (RS-422)
3	DGND	Digital ground
4	V+	IMU-IGM power supply input, positive
5	V-	IMU-IGM power supply input, negative
6	MIC_RX/MIC_RX+	MODE2 open: MIC port receiver (RS-232) MODE2 low: MIC port receive positive (RS-422)
7	MIC_RX-	MODE2 open: No connection MODE2 low: MIC port receive negative (RS-422)
8	DGND	Digital ground
9	Reserved	Reserved
10	Reserved	Reserved
11	DGND	Digital ground
12	Reserved	Reserved
13	MODE2	Mode 2 input, controls MIC port standard
14	Reserved	Reserved
15	Reserved	Reserved

**Table 58: IMU-IGM AUX Port Pinout**

Pin #	Label	Description
1	ODM_A+	Wheel sensor input A positive
2	ODM_B+	Wheel sensor input B positive (No connection on IMU-IGM-S1)
3	Reserved	Reserved
4	WS_VOUT	Wheel sensor output voltage (12 VDC)
5	DGND	Digital ground

Pin #	Label	Description
6	ODM_A-	Wheel sensor input A negative
7	ODM_B-	Wheel sensor input B negative (No connection on IMU-IGM-S1)
8	Reserved	Reserved
9	DGND	Digital ground
10	Reserved	Reserved
11	Reserved	Reserved
12	Reserved	Reserved
13	Reserved	Reserved
14	Reserved	Reserved
15	DGND	Digital ground

### A.5.3 IMU-IGM Sensor Specifications

**Table 59: IMU-IGM-A1 IMU Performance**

<b>Gyroscope Performance</b>	
Gyro Input Range	$\pm 450$ °/second
In Run Gyro Rate Bias Stability	6.25 °/hour
Angular Random Walk	0.3 °/ $\sqrt{\text{hour}}$
<b>Accelerometer Performance</b>	
Accelerometer Range	$\pm 18$ g
In Run Accelerometer Bias Stability	0.1 mg
Velocity Random Walk	0.029 m/s/ $\sqrt{\text{hour}}$
<b>Data Rate</b>	
IMU Measurement	200 Hz

**Table 60: IMU-IGM-S1 IMU Performance**

<b>Gyroscope Performance</b>	
Gyro Input Range	$\pm 400$ °/second
In Run Gyro Rate Bias Stability	0.5 °/hour
Angular Random Walk	0.15 °/ $\sqrt{\text{hour}}$
<b>Accelerometer Performance</b>	
Accelerometer Range	$\pm 10$ g
In Run Accelerometer Bias Stability	0.05 mg
Velocity Random Walk	0.07 m/s/ $\sqrt{\text{hour}}$
<b>Data Rate</b>	
IMU Measurement	125 Hz

### A.5.4 IMU-IGM Electrical and Environmental

**Table 61: IMU-IGM-A1 Electrical Specifications**

Electrical	
Input Voltage	10 - 30 VDC
Power consumption	2.5 W (typical)

**Table 62: IMU-IGM-A1 Environmental Specifications**

Environmental	
Temperature, operational	-40°C to +65°C
Temperature, storage	-50°C to +80°C
Humidity	95% Non-condensing

**Table 63: IMU-IGM-S1 Electrical Specifications**

Electrical	
Input Voltage	10 - 30 VDC
Power consumption	<4.6 W (typical)

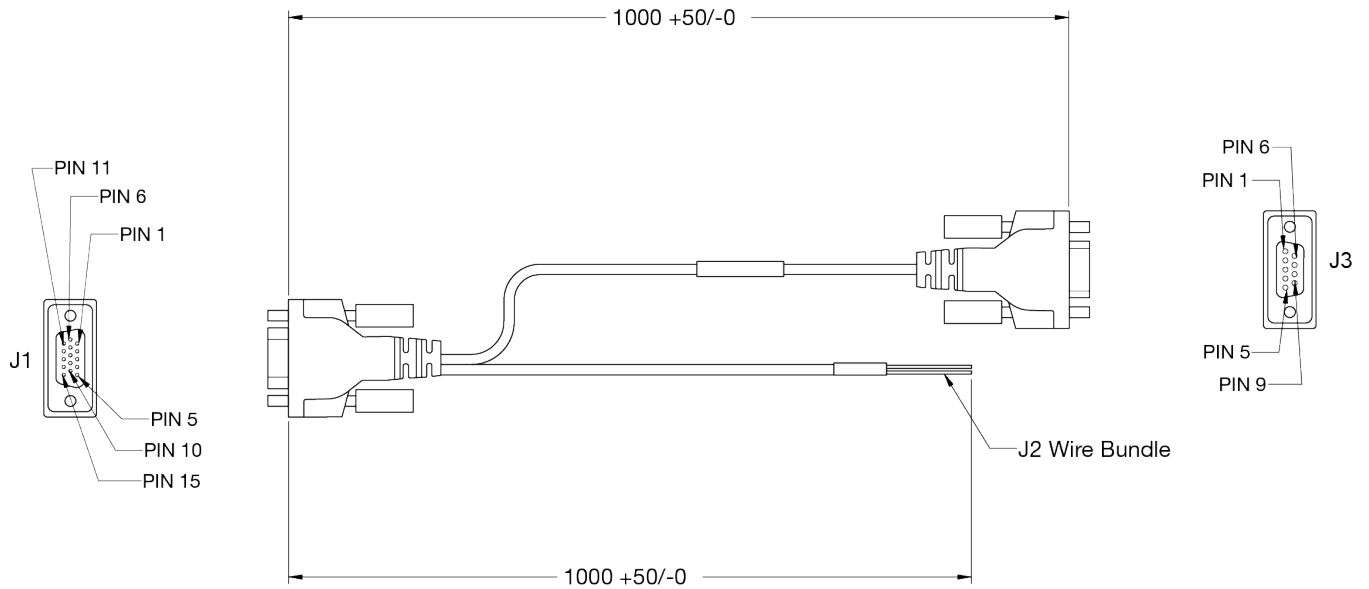
**Table 64: IMU-IGM-S1 Environmental Specifications**

Environmental	
Temperature, operational	-40°C to +65°C
Temperature, storage	-50°C to +80°C
Humidity	95% Non-condensing

### A.5.5 IMU-IGM Interface Cable

The NovAtel part number for the IMU-IGM interface cable is 01019016. This cable provides power to the IMU-IGM and communication signals between the IMU-IGM and the OEM7 family receiver.

**Figure 53: IMU-IGM Interface Cable**



The dimensions in this drawing are in millimeters.

**Table 65: IMU-IGM Interface Cable Pinout Descriptions**

J1 MAIN Pin #	Function	J2 Wire Bundle Label	J3 MIC Port Pin #
1	MIC Port Transmit/Transmit+ (RS-422)		2
2	MIC Port Transmit- (RS-422)		8
3	Digital Ground		
4	Battery +	BATT+	
5	Digital Ground	BATT-	
6	MIC Port Receive/Receive+ (RS-422)		3
7	MIC Port Receive- (RS-422)		7
8	Digital Ground		5
9	Reserved		
10	Reserved		



J1 MAIN Pin #	Function	J2 Wire Bundle Label	J3 MIC Port Pin #
11	Digital Ground		
12	Reserved		
13	MODE 2	MODE 2	
14	Reserved		
15	Reserved		



The MIC port can operate as either an RS-232 or RS-422 serial port.

- To set the MIC port to RS-232, leave the MODE 2 pin open/unconnected.
- To set the MIC port to RS-422, tie the MODE 2 pin low.

### Custom Cable Recommendations

The tables below provide recommendations for creating custom cables to replace the IMU-IGM interface cable (01019016).

**Table 66: Connectors**

Connector	Description
J1	DB-15HD, male
J2	DB-9, female

**Table 67: Maximum Cable Length**

IMU	RS-232	RS-422
IMU-IGM-A1, IMU-IGM-S1	< 1.2 meters	< 50 meters

## A.6 IMU-ISA-100C

The IMU-ISA-100C contains an ISA-100C IMU.

**Table 68: IMU-ISA-100C Physical Specifications**

Physical	
IMU Enclosure Size	180 mm x 150 mm x 137 mm
IMU Enclosure Weight	5.0 kg

See the following sections for more information about the IMU-ISA-100C IMU.

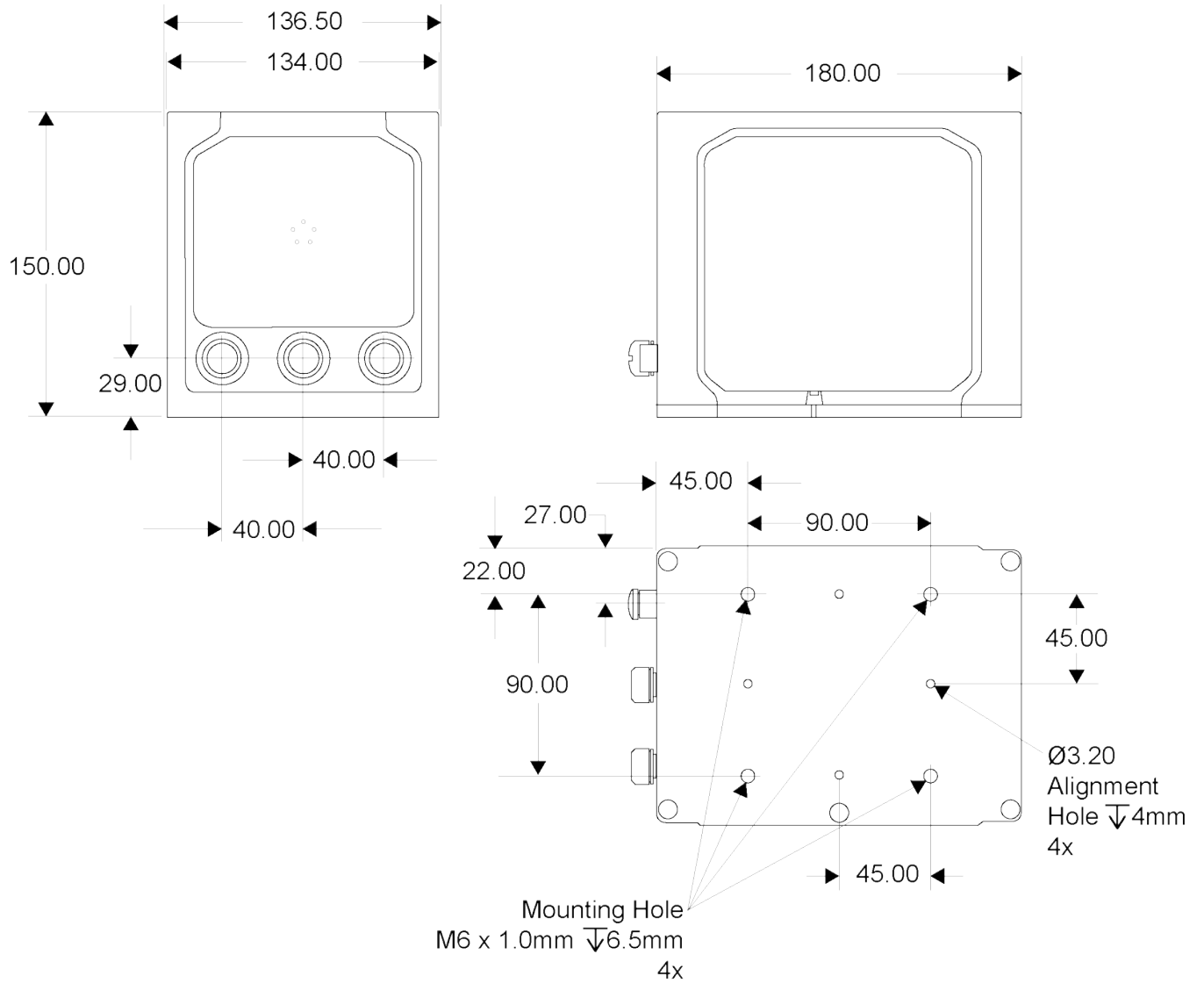
- *IMU-ISA-100C Mechanical Drawings* on the next page
- *Optional Side Mounting Holes* on page 173
- *IMU-ISA-100C Performance* on page 175
- *IMU-ISA-100C Electrical and Environmental* on page 176
- *IMU Enclosure Interface Cable* on page 177
- *IMU Enclosure Power Cable* on page 179
- *IMU Enclosure Wheel Sensor Cable* on page 180

**A.6.1 IMU-ISA-100C Mechanical Drawings**

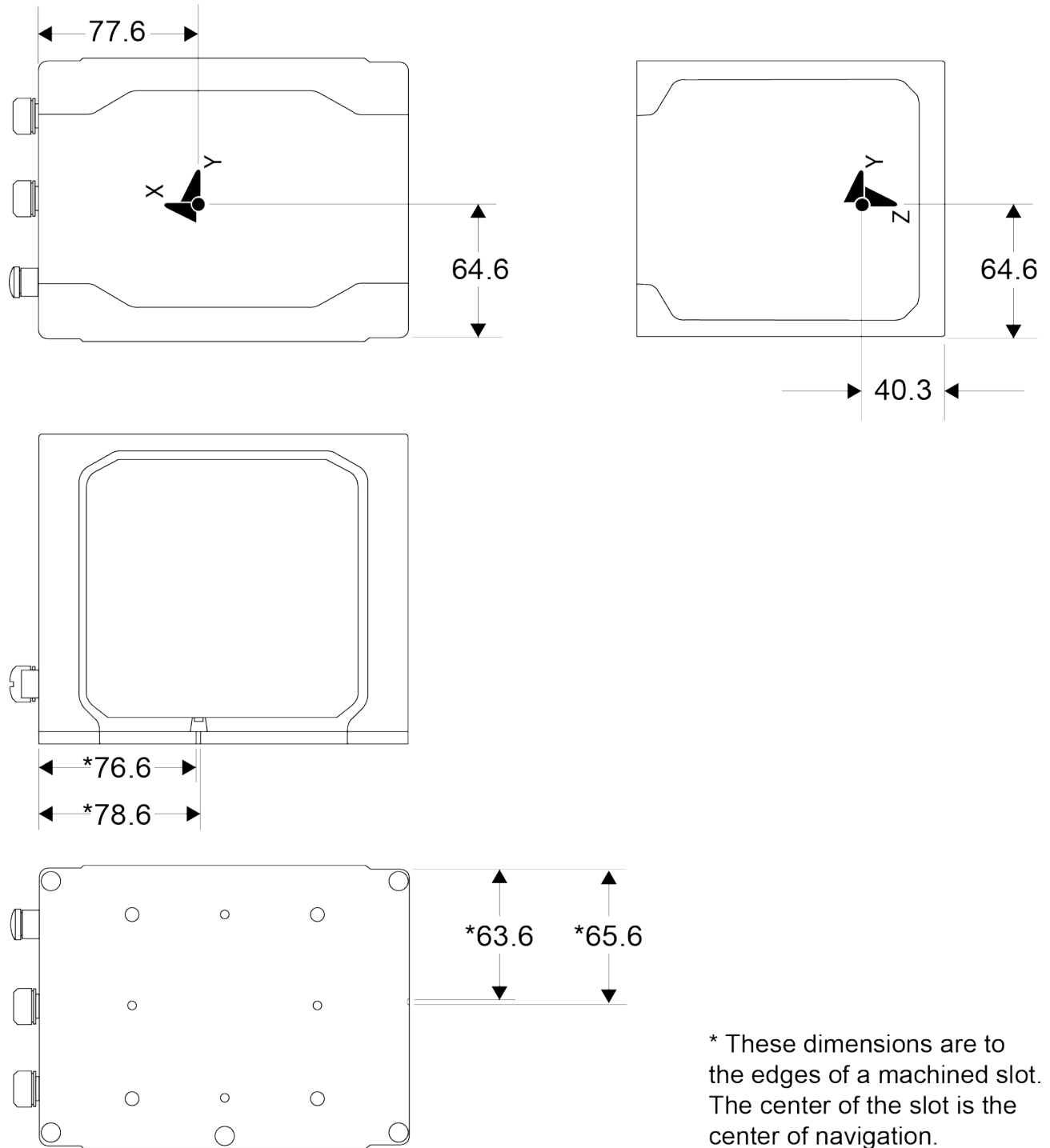


The dimensions in the following diagrams are in millimeters.

**Figure 54: IMU-ISA-100C Dimensions**



**Figure 55: IMU-ISA-100C Center of Navigation**

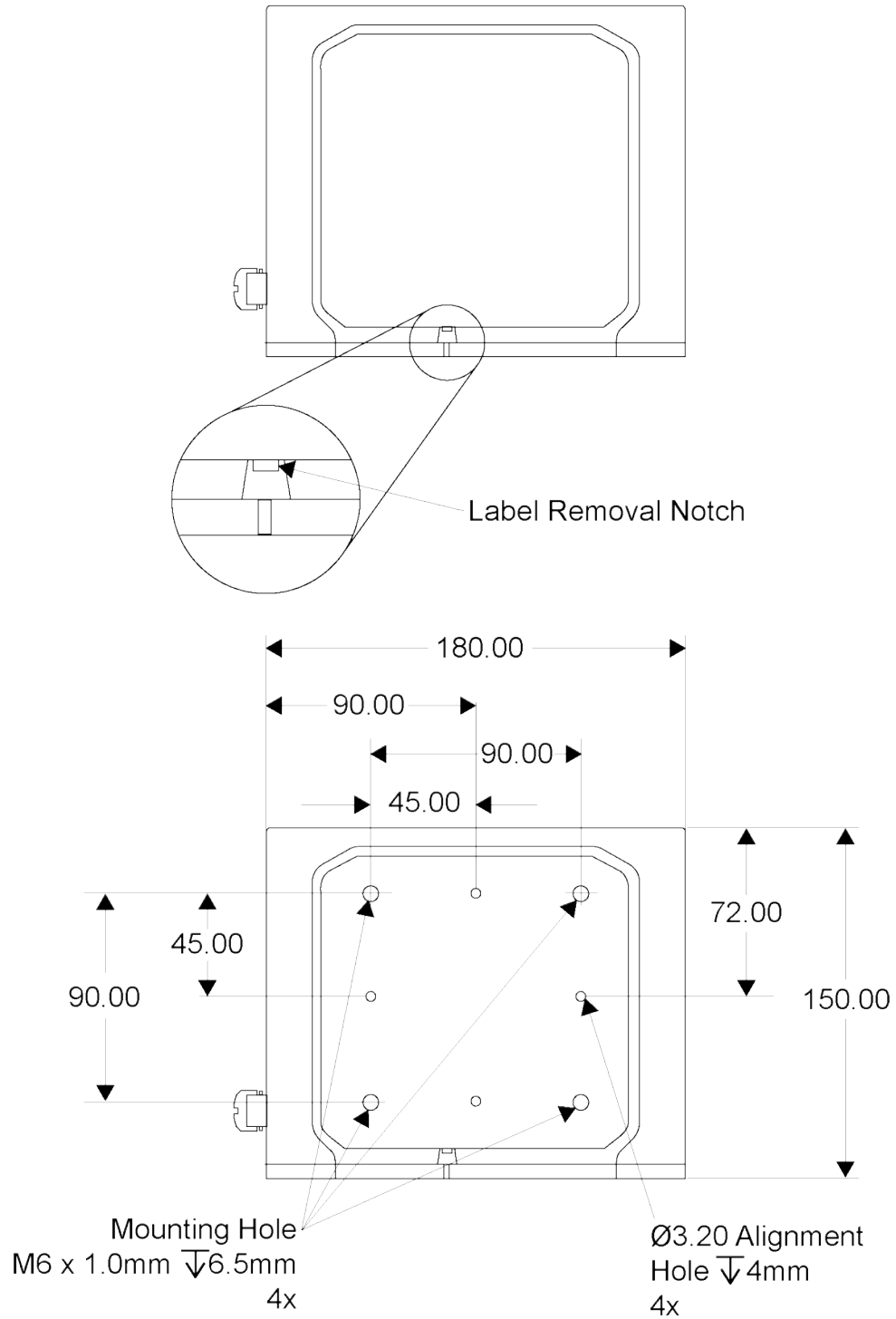


### ***A.6.2 Optional Side Mounting Holes***

There are mounting and alignment holes on both sides of the IMU enclosure to allow the IMU to be mounted on its side. These holes have the same pattern and spacing as the mounting and alignment holes on the bottom of the IMU enclosure.

To access these holes, the NovAtel label must be removed from the side of the enclosure. A small notch on the side of enclosure allows you to insert a small flat blade screw under the label to start lifting the label.

**Figure 56: Optional Side Mounting Holes**



**A.6.3 IMU-ISA-100C Performance****Table 69: IMU-ISA-100C IMU Performance**

<b>Gyroscope Performance</b>	
Input range	$\pm 495$ °/second
In-run bias stability	$\leq 0.05$ °/hour
Scale factor repeatability	$\leq 100$ ppm
Scale factor non-linearity	$\leq 100$ ppm
Angular random walk	$0.012$ °/ $\sqrt{\text{hour}}$
<b>Accelerometer Performance</b>	
Range	$\pm 10$ g
In-run bias stability	$\leq 100$ $\mu\text{g}$
1 year scale factor repeatability	$\geq 1250$ ppm
Scale factor non-linearity	$\leq 100$ ppm
Velocity random walk	$\leq 100$ $\mu\text{g}/\sqrt{\text{Hz}}$
<b>Data Rate</b>	
IMU Measurement	200 Hz

**A.6.4 IMU-ISA-100C Electrical and Environmental****Table 70: IMU-ISA-100C Electrical Specifications**

<b>Electrical</b>	
IMU Power Consumption	18 W (typical)
IMU Input Voltage	+10 to +34 VDC
IMU Interface	RS-422
<b>Connectors</b>	
Power	SAL M12, 5 pin, male
Data	SAL M12, 5 pin, female
Wheel Sensor	SAL M12, 8 pin, male

**Table 71: IMU-ISA-100C Environmental Specifications**

<b>Environmental</b>	
Operating Temperature	-40°C to +55°C
Storage Temperature	-40°C to +85°C
Humidity	MIL-STD-810G, Method 507.5
Random Vibe	MIL-STD-810G, Method 514.6 (2.0 g)
Environmental	IEC 60529 IP67



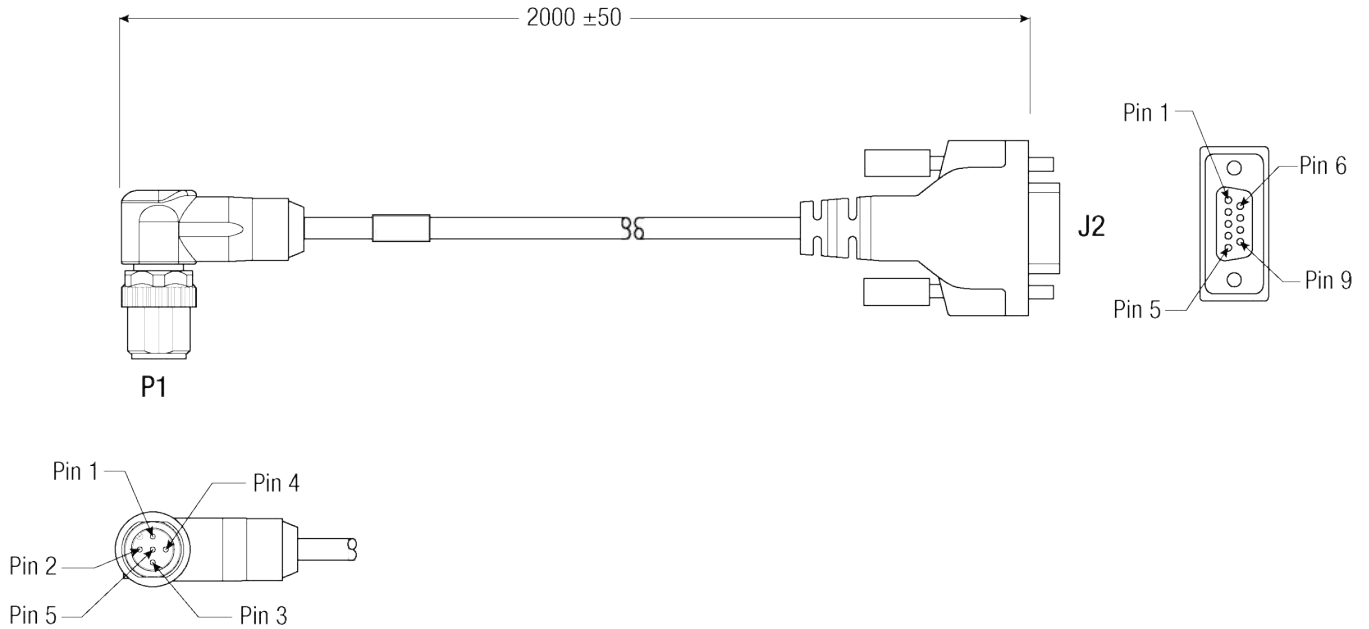
### A.6.5 IMU Enclosure Interface Cable

The NovAtel part number for the IMU Enclosure interface cable is 01019319 (see *Figure 57: IMU Enclosure Interface Cable* below). This cable enables communication between the receiver and the IMU.



This cable is used for all versions of the IMU Enclosure (IMU-ISA-100C, IMU-ENC-LN200, IMU-HG1900 and IMU-μIMU-IC).

**Figure 57: IMU Enclosure Interface Cable**



Dimensions are in millimeters.

**Table 72: IMU Enclosure Interface Cable Pinouts**

P1 Pinout (M12)	Function	J2 Pinout (DB9)
1	TX+	2
2	RX+	3
3	TX-	8
4	RX-	7
5	GND	5
Shield	Shield	Shield

## Custom Cable Recommendations

The tables below provide recommendations for creating custom cables to replace the IMU Enclosure interface cable (01019319).

**Table 73: Connectors**

Connector	Description
P1	M12x1, 5 position, male
J2	DB-9, female

**Table 74: Maximum Cable Length**

IMU	RS-422
IMU-ISA-100C	< 50 meters

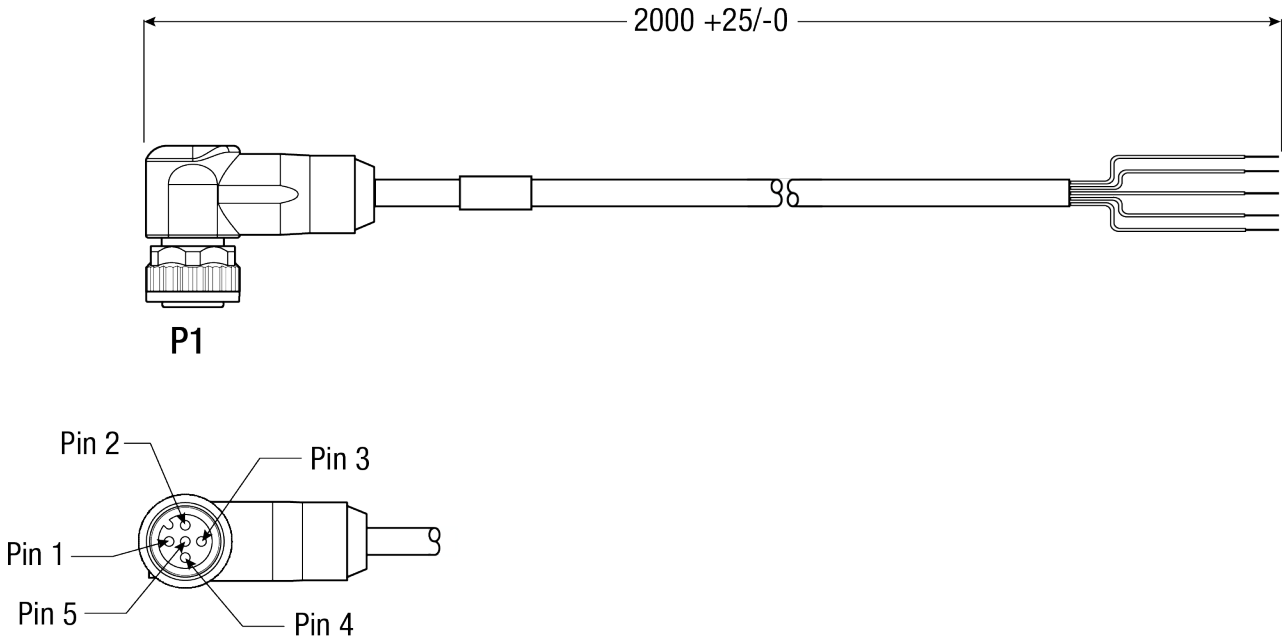
### A.6.6 IMU Enclosure Power Cable

The NovAtel part number for the IMU Enclosure power cable is 60723136 (see *Figure 58: IMU Enclosure Power Cable* below). This cable provides power to the IMU from an external power source.



This cable is used for all versions of the IMU Enclosure (IMU-ISA-100C, IMU-ENC-LN200, IMU-HG1900 and IMU-μIMU-IC).

**Figure 58: IMU Enclosure Power Cable**



Dimensions are in millimeters.

**Table 75: IMU Enclosure Power Cable Pinouts**

P1 Pinout (M12)	Function	Bare Wire Color
1	VIN-	Brown
2	VIN+	White
3	VIN+	Blue
4	VIN-	Black
5	Chassis Ground	Grey



This cable uses a M12x1, 5 position, female connector.

### A.6.7 IMU Enclosure Wheel Sensor Cable

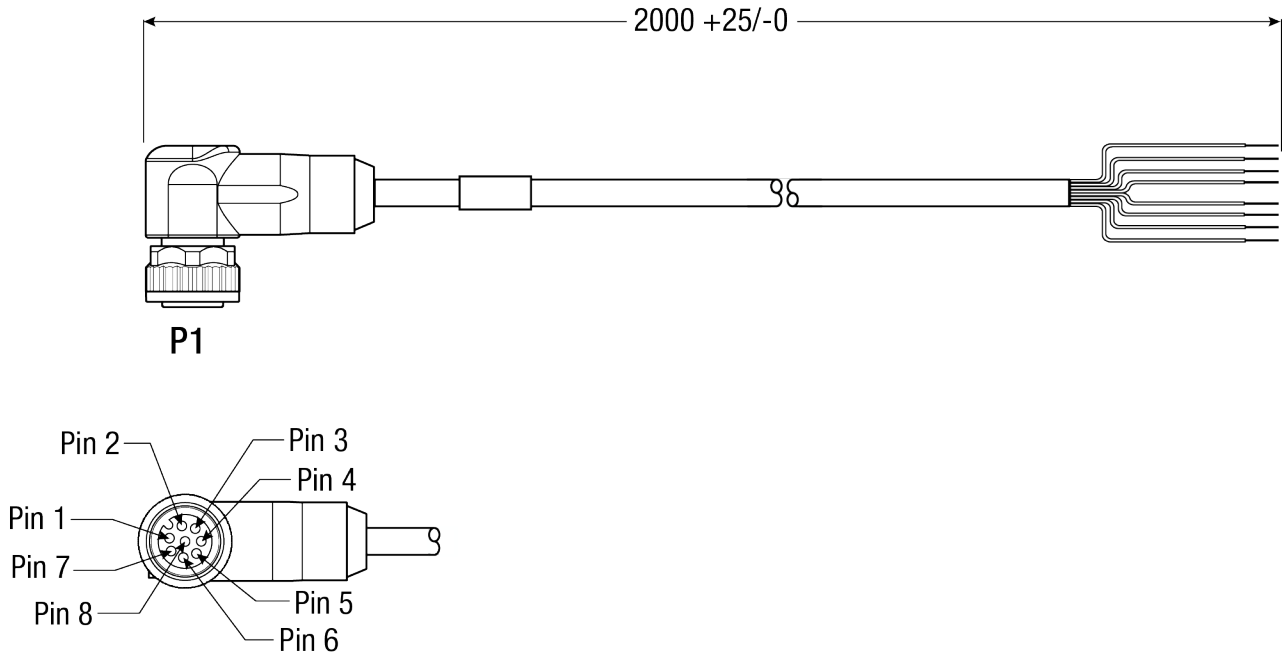
The NovAtel part number for the IMU Enclosure wheel sensor cable is 60723137 (see *Figure 59: IMU Enclosure Wheel Sensor Cable* below). This cable enables communication between the IMU and the wheel sensor.



This cable is used for all versions of the IMU Enclosure (IMU-ISA-100C, IMU-ENC-LN200, IMU-HG1900 and IMU-μIMU-IC).

See also *DMI Connected to an IMU* on page 113.

**Figure 59: IMU Enclosure Wheel Sensor Cable**



Dimensions are in millimeters.

**Table 76: IMU Enclosure Wheel Sensor Cable Pinouts**

P1 Pinout (M12)	Function	Bare Wire Color
1	A+	White
2	B+	Brown
3	Chassis Ground	Green
4	A-	Yellow
5	B-	Grey

P1 Pinout (M12)	Function	Bare Wire Color
6	Chassis Ground	Pink
7	Reserved	Blue
8	Reserved	Red

### Custom Cable Recommendations

The tables below provide recommendations for creating custom cables to replace the IMU Enclosure Wheel Sensor cable (60723137).

**Table 77: Connectors**

Connector	Description
P1	M12x1, 8 position, female
J2	DB-9, female

**Table 78: Maximum Cable Length**

IMU	RS-422
IMU-ISA-100C	< 50 meters
IMU-ENC-LN200	
IMU-HG1900	
IMU-μIMU-IC	

## A.7 IMU-KVH1750

**Table 79: IMU-KVH1750 Physical Specifications**

Physical	
Enclosure Size (Ø x H)	88.9 mm X 73.7 mm
Weight	<0.7 kg

See the following sections for more information about the IMU-KVH-1750.

- *IMU-KVH1750 Mechanical Drawings* on the next page
- *IMU-KVH1750 Sensor Specifications* on page 187
- *IMU-KVH1750 Electrical and Environmental* on page 188
- *IMU-KVH1750 Cable* on page 189

**A.7.1 IMU-KVH1750 Mechanical Drawings**



The dimensions in the following diagrams are in millimeters.

**Figure 60: IMU-KVH1750 Bottom view**

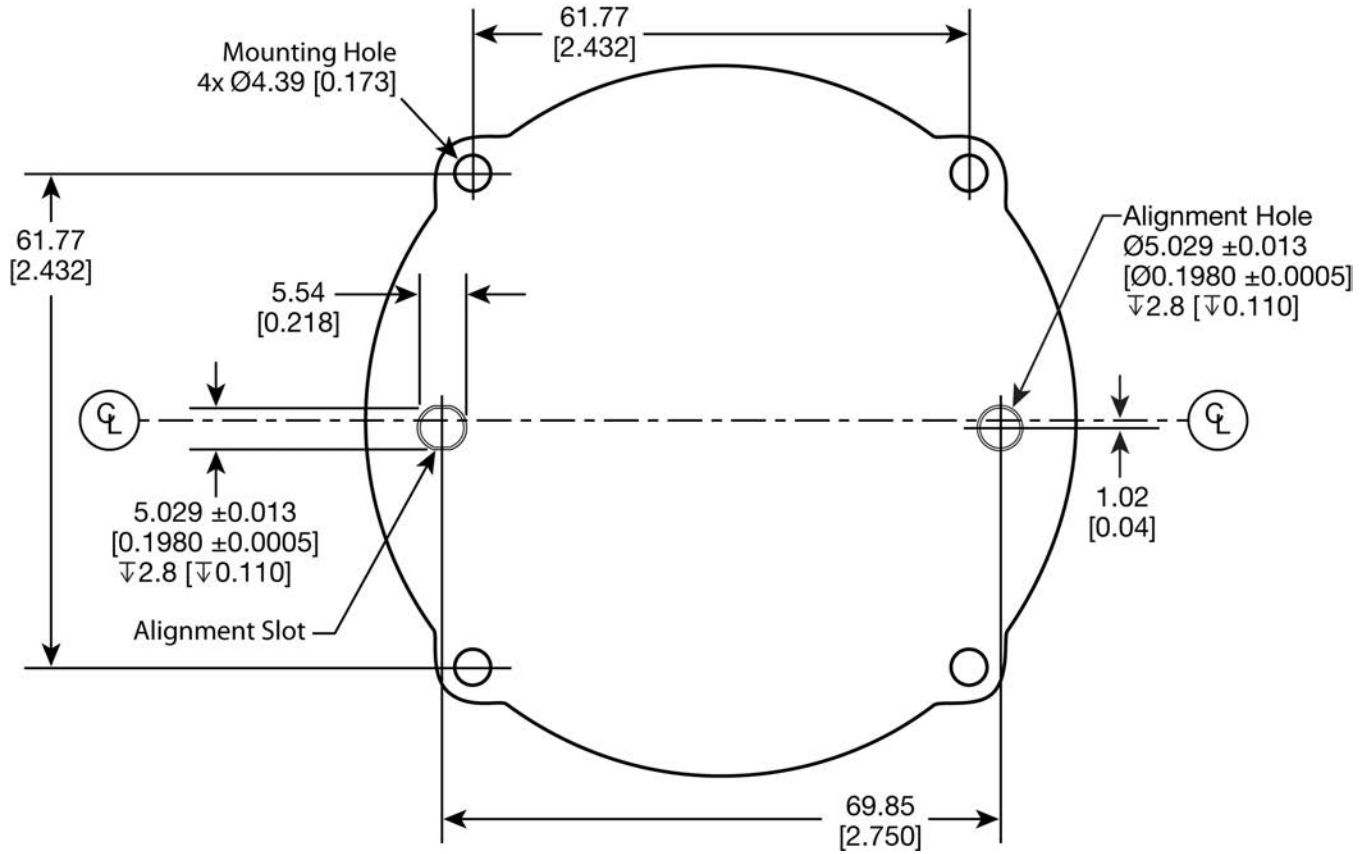


Figure 61: IMU-KVH1750 Top View

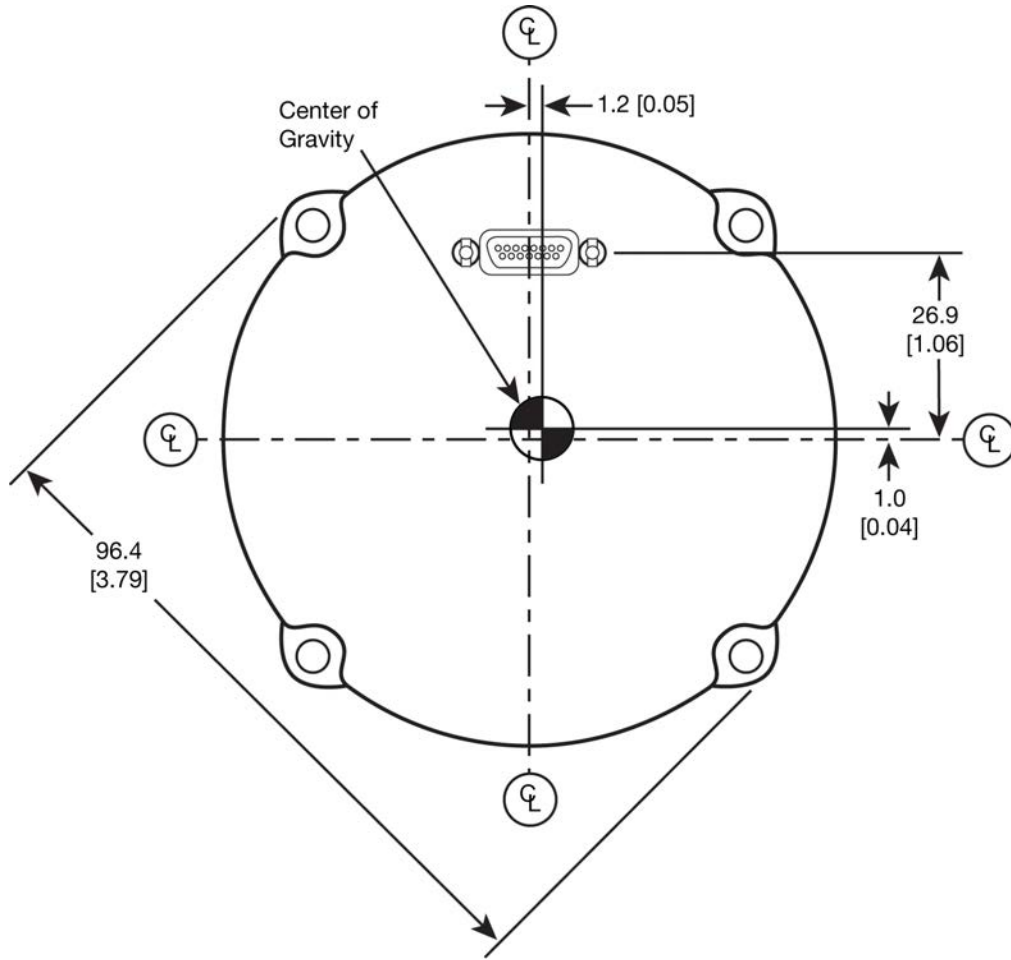




Figure 62: IMU-KVH1750 Side View

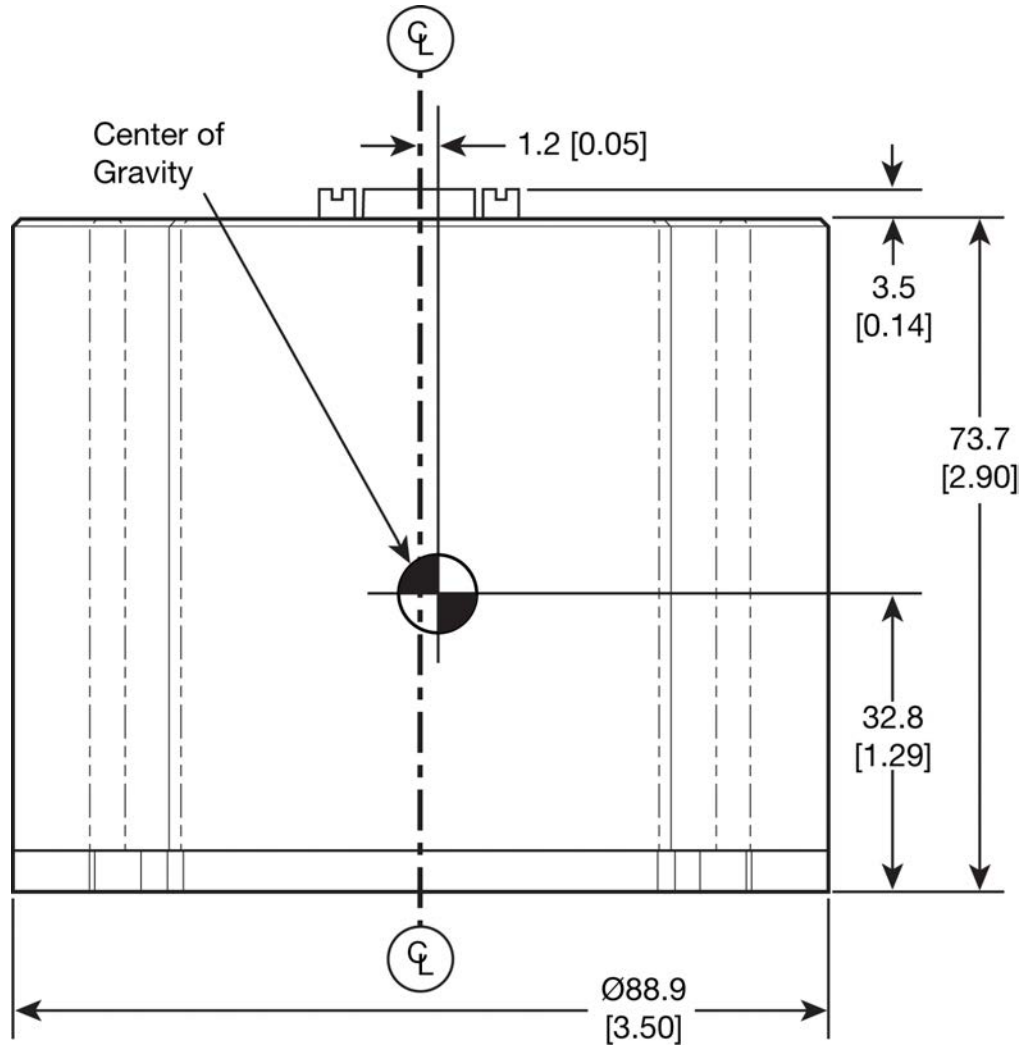
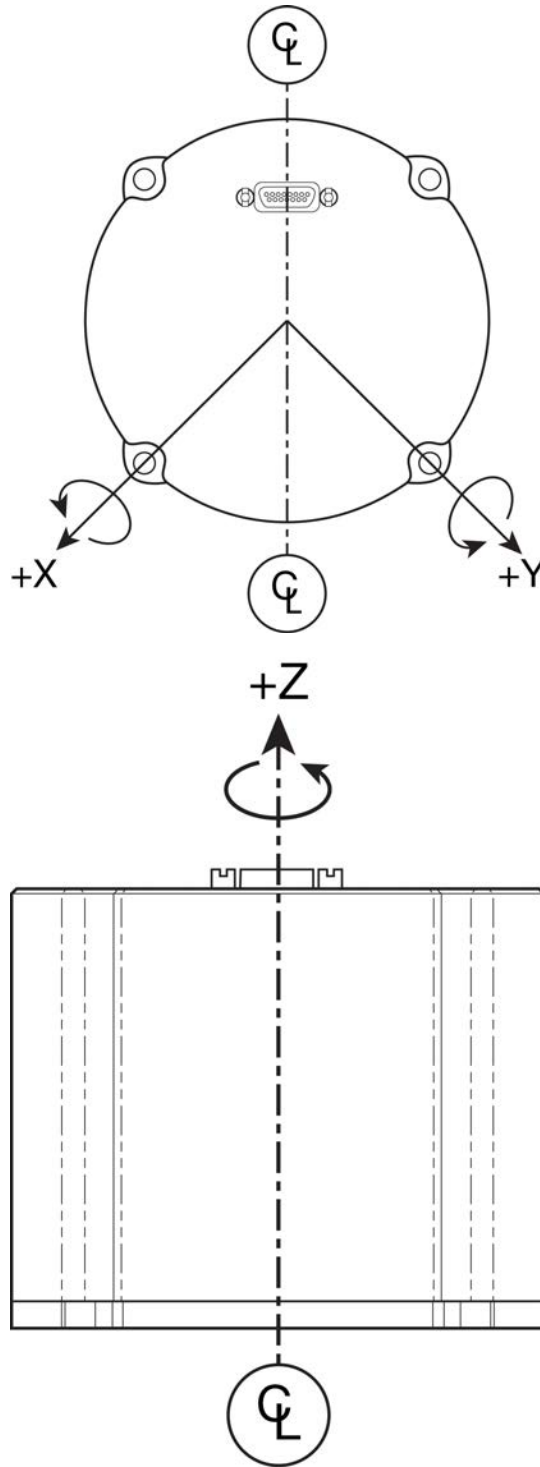


Figure 63: IMU-KVH1750 Gyro Axes



**A.7.2 IMU-KVH1750 Sensor Specifications****Table 80: IMU-KVH1750 Performance**

<b>Gyroscope Performance</b>	
Maximum Input Rate	$\pm 490$ °/second
Bias Stability (constant temperature)	0.05°/hour (typical) 0.1°/hour (max)
Bias Temperature Sensitivity (full temp.)	0.7°/hour (typical) 1°/hour (max)
Bias Offset (at 25° C)	$\pm 2$ °/hour
Scale Factor (nominal)	$1 \pm 0.2\%$
Scale Factor Non-linearity (at 25° C)	$\leq 50$ ppm
Scale Factor Temperature Sensitivity	$\leq 200$ ppm
Angular Random Walk	$\leq 0.012$ °/ $\sqrt{\text{hour}}$
Input Axis Misalignment	$\pm 0.4$ mrad
<b>Accelerometer Performance</b>	
Maximum Input	$\pm 10$ g
Bias Stability (at 25° C)	$\leq 0.05$ mg
Scale Factor Temperature Sensitivity	$\leq 100$ ppm/°C (typical) 250 ppm/°C (max)
Velocity Random Walk	0.12 mg/ $\sqrt{\text{Hz}}$
Input Axis Misalignment	$\pm 1.0$ mrad
<b>Data Rate</b>	
IMU Measurement	200 Hz

**A.7.3 IMU-KVH1750 Electrical and Environmental****Table 81: IMU-KVH1750 Electrical Specifications**

<b>Electrical</b>	
Input Voltage	9 - 36 VDC
Power Consumption	5W (typical), 8W (max)
Turn-On Time (room temp.)	≤1.25 seconds
Full Performance Time (room temp.)	≤60 seconds
IMU Interface	RS-422
<b>Connectors</b>	
Power and I/O	15-pin Micro-D (male)

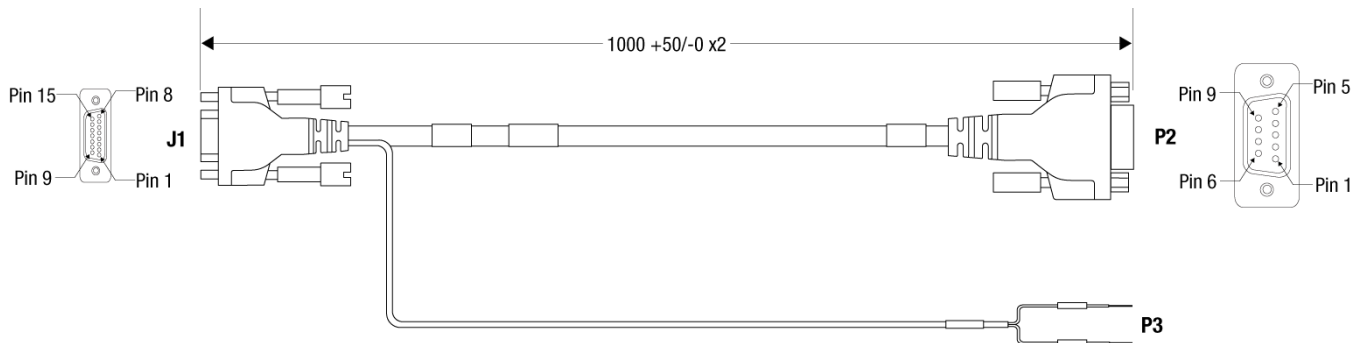
**Table 82: IMU-KVH1750 Environmental Specifications**

<b>Environmental</b>	
Temperature, operational	-40°C to +75°C
Temperature, non-operational	-50°C to +85°C
Vibration, operational	8 g rms, 20 Hz -2 kHz
Vibration, non-operational	12 g rms, 20 Hz -2 kHz
Shock, operational	9 g (11 ms, sawtooth)
Shock, non-operational	40 g (11 ms, sawtooth)

### A.7.4 IMU-KVH1750 Cable

The NovAtel part number for the IMU-KVH1750 cable is 01019211. This cable provides power to the IMU from an external power source and enables communication between the receiver and the IMU.

**Figure 64: IMU-KVH1750 Cable**



Dimensions are in millimeters.

**Table 83: IMU-KVH1750 Connector Pinout Descriptions**

J1 (15 Pin Micro D Female)		P2 (Female DB9)		P3
Pin #	Signal Name	Pin #	Signal Name	Labels
1	TX+	2	RX+	
2	TX-	8	RX-	
3	RX-	7	TX-	
4	RX+	3	TX+	
5	Reserved			
6	Reserved			
7	Reserved			
8	Reserved			
9	Power Return			PWR-
10	VDC Power			PWR+
11	MSync	1	IMU Event Out (Sync)	
12	TOV-Out	9	Event In	
13	Reserved			
14	Reserved			
15	Signal Ground	5	Signal Ground	
Shell	Chassis Ground	Shell	Chassis Ground	



A hardware change by KVH regarding KVH1750 IMUs (manufactured after November 2015) expect a differential MSYNC signal input (J1 (15 pin micro D female) of the IMU: Pin 11 MSync+, Pin 7 MSync-). This was previously a single ended input signal on Pin 11 only. The NovAtel VARF signal used to provide the MSYNC to the IMU remains single ended, however significant testing has been completed with the existing IMU-KVH1750 Cable (01019211) in safe environments (no interference sources). No issues or failures have been observed. There are no plans to modify NovAtel cables at this time. However, for any custom or OEM cable solutions, it is recommended to follow KVH guidelines in providing a differential MSYNC signal, converting the VARF to differential and properly shielding for optimal reliability.

**Custom Cable Recommendations**

The tables below provide recommendations for creating custom cables to replace the IMU-KVH1750 cable (01019211).

**Table 84: Connectors**

Connector	Description
J1	Micro-D, 15-pin, female
J2	DB-9, female

**Table 85: Maximum Cable Length**

IMU	RS-422
IMU-KVH1750	< 1.5 meters

## A.8 IMU-ENC-LN200

The IMU-ENC-LN200 contains an LN200 or LN200C IMU.

**Table 86: IMU-ENC-LN200 Physical Specifications**

Physical	
IMU Enclosure Size	150 mm x 134 mm x 134 mm
IMU Enclosure Weight	3.2 kg

See the following sections for more information about the IMU-ENC-LN200.

- *IMU-ENC-LN200 Mechanical Drawings* on the next page
- *IMU-ENC-LN200 Sensor Specifications* on page 194
- *IMU-ENC-LN200 Electrical and Environmental* on page 195
- *IMU-ENC-LN200 Cables* on page 195

**A.8.1 IMU-ENC-LN200 Mechanical Drawings**



The dimensions in the following diagrams are in millimeters.

**Figure 65: IMU-ENC-LN200 Dimensions**

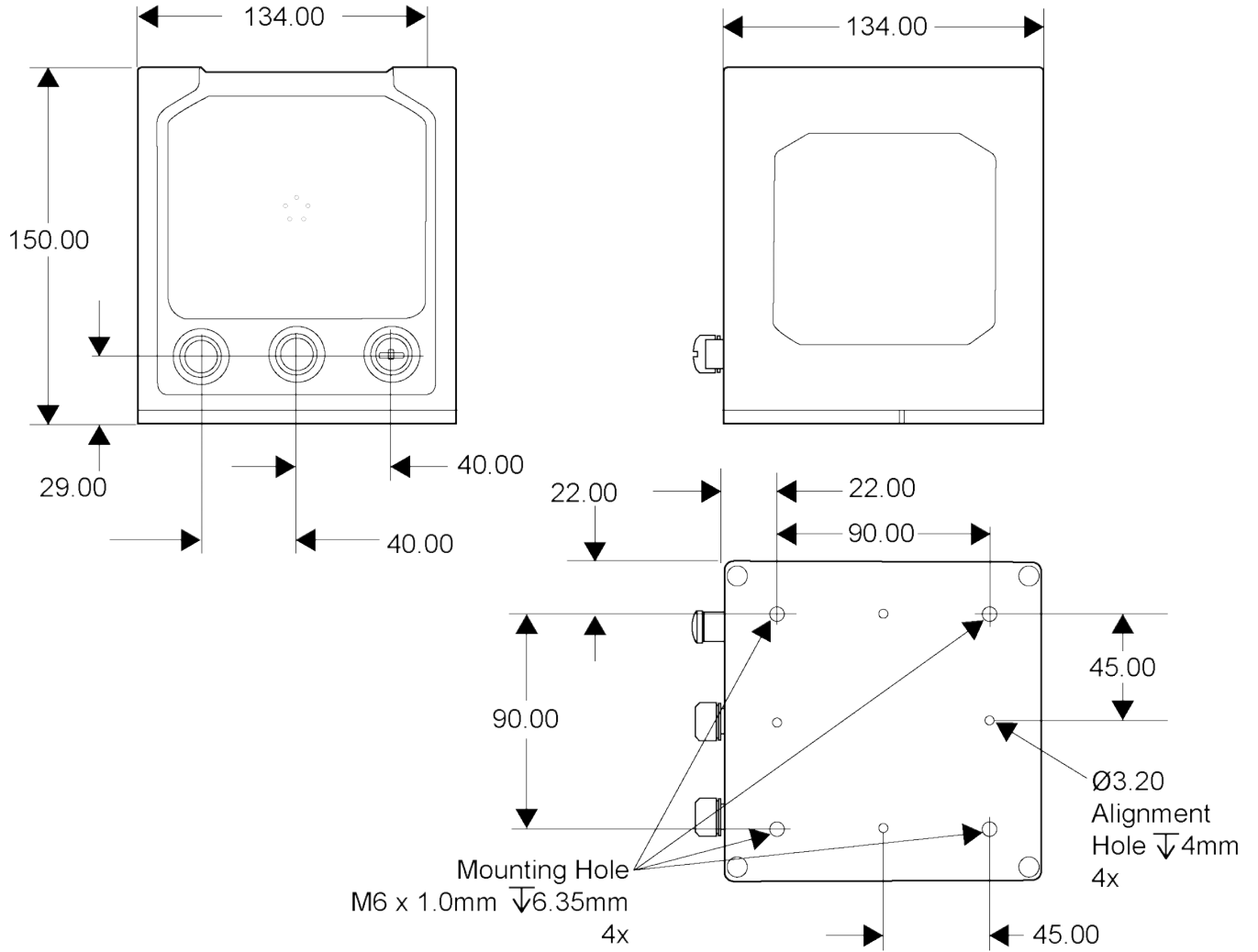
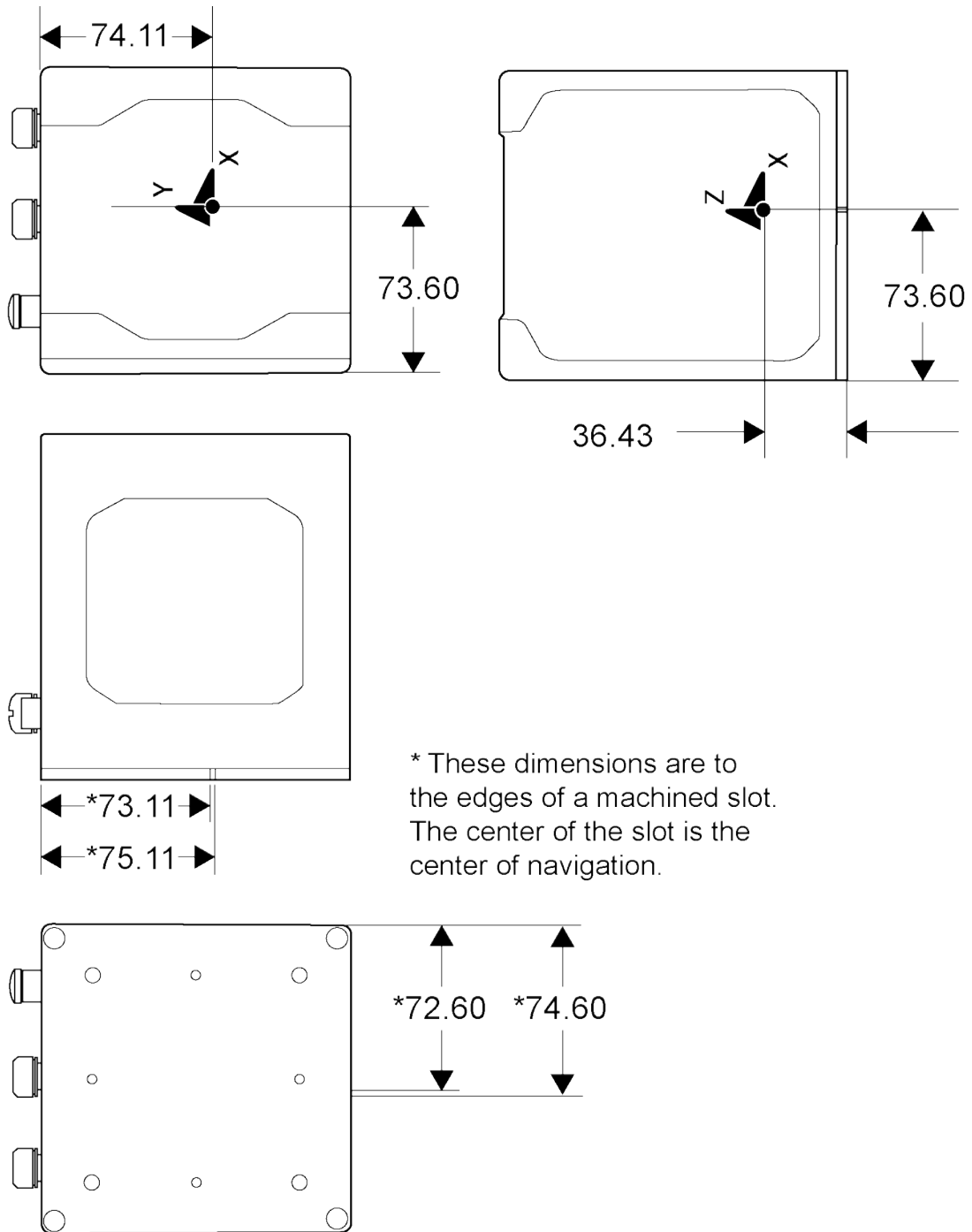




Figure 66: IMU-ENC-LN200 Center of Navigation



**A.8.2 IMU-ENC-LN200 Sensor Specifications**

**Table 87: IMU-ENC-LN200 IMU Performance**

<b>Gyroscope Performance</b>	
Input range	±1000 °/second
Rate bias	1.0 °/hour
Scale factor error	100 ppm
Angular random walk	0.07 °/√hour
<b>Accelerometer Performance</b>	
Input range	±40 g
Scale factor asymmetry	150 ppm
Scale factor error	300 ppm
Bias	0.3 mg
<b>Data Rate</b>	
IMU Measurement	200 Hz

**Table 88: IMU-ENC-LN200C IMU Performance**

<b>Gyroscope Performance</b>	
Input range	±490 deg/sec
Rate bias	1.0 deg/hr
Scale factor error	100 ppm
Angular random walk	0.07 deg/√hr
<b>Accelerometer Performance</b>	
Input range	±15 g
Scale factor asymmetry	150 ppm
Scale factor error	300 ppm
Bias	1.0 mg
<b>Data Rate</b>	
IMU Measurement	200 Hz

### A.8.3 IMU-ENC-LN200 Electrical and Environmental

**Table 89: IMU-ENC-LN200 Electrical Specifications**

Electrical	
IMU Power Consumption	14 W (typical)
IMU Input Voltage	+10 to +34 VDC
IMU Interface	RS-422
Connectors	
Power	SAL M12, 5 pin, male
Data	SAL M12, 5 pin, female
Wheel Sensor	SAL M12, 8 pin, male

**Table 90: IMU-ENC-LN200 Environmental Specifications**

Environmental	
Operating Temperature	-40°C to +55°C
Storage Temperature	-40°C to +80°C
Humidity	MIL-STD-810G(Ch1), Method 507.6
Random Vibe	MIL-STD-810G(Ch1), Method 514.7 (2.0 g)
Environment	MIL-STD-810G(Ch1), Method 512.6 IEC 60529 IP67

### A.8.4 IMU-ENC-LN200 Cables

#### IMU-ENC-LN200 Interface Cable

The IMU-ENC-LN200 uses the IMU Enclosure Interface Cable. Refer to *IMU Enclosure Interface Cable* on page 177 for details about this cable.

#### IMU-ENC-LN200 Power Cable

The IMU-ENC-LN200 uses the IMU Enclosure Power Cable. Refer to *IMU Enclosure Power Cable* on page 179 for details about this cable.

#### IMU-ENC-LN200 Wheel Sensor Cable

The IMU-ENC-LN200 uses the IMU Enclosure Wheel Sensor Cable. Refer to *IMU Enclosure Wheel Sensor Cable* on page 180 for details about this cable.

## A.9 IMU- $\mu$ IMU-IC

The IMU- $\mu$ IMU-IC contains a Litef  $\mu$ IMU.

**Table 91: IMU- $\mu$ IMU-IC Physical Specifications**

Physical	
IMU Enclosure Size	130 mm x 130 mm x 115 mm
IMU Enclosure Weight	2.57 kg

See the following sections for more information about the IMU- $\mu$ IMU.

- *IMU- $\mu$ IMU-IC Mechanical Drawings* on the next page
- *IMU- $\mu$ IMU-IC Sensor Specifications* on page 199
- *IMU- $\mu$ IMU-IC Electrical and Environmental* on page 200
- *IMU- $\mu$ IMU-IC Cables* on page 200

**A.9.1 IMU- $\mu$ IMU-IC Mechanical Drawings**



The dimensions in the following diagrams are in millimeters.

**Figure 67: IMU- $\mu$ IMU-IC Dimensions**

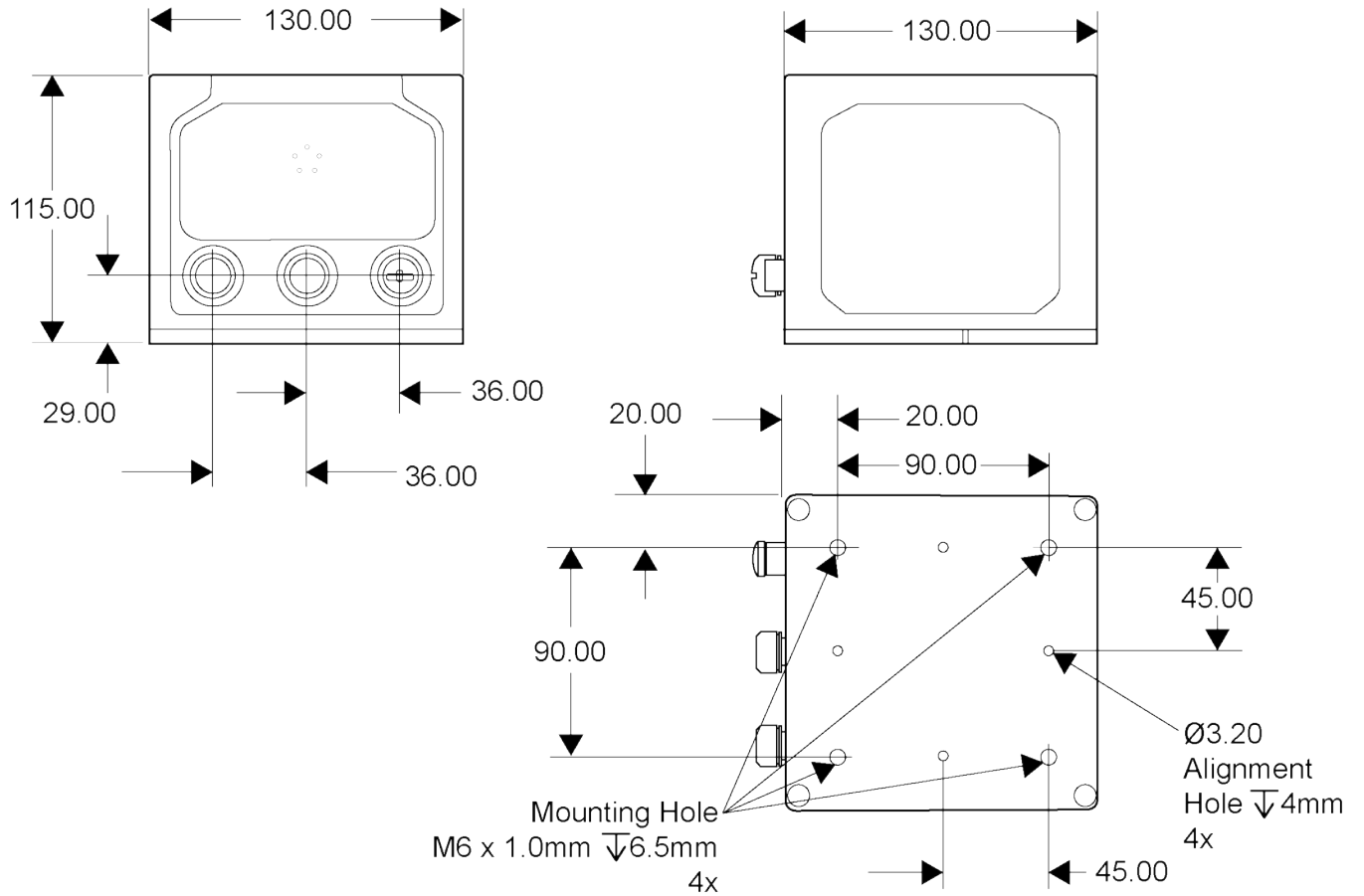
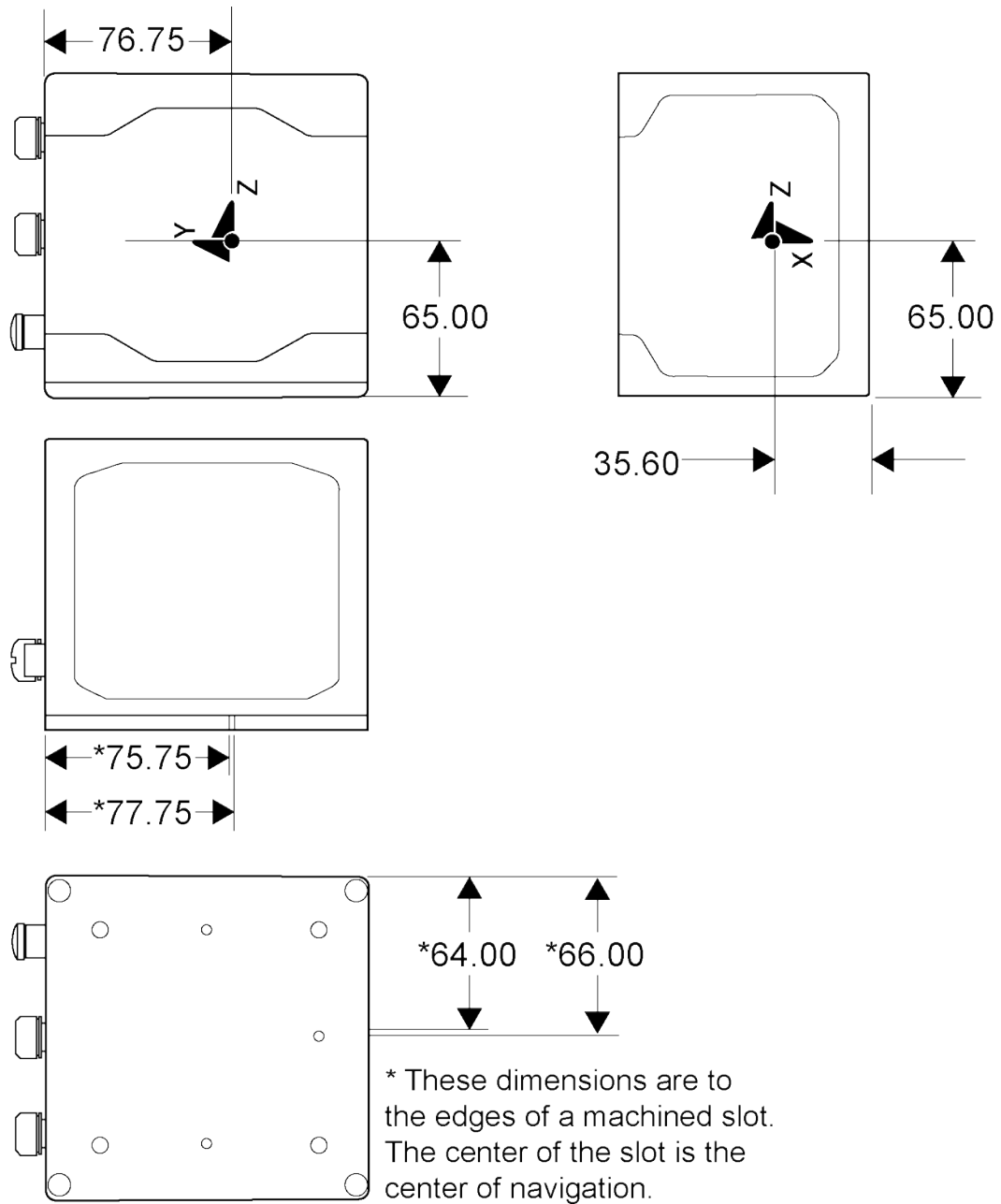


Figure 68: IMU-μIMU-IC Center of Navigation



**A.9.2 IMU- $\mu$ IMU-IC Sensor Specifications****Table 92: IMU- $\mu$ IMU-IC IMU Performance**

<b>Gyroscope Performance</b>	
Input range	$\pm 499$ °/second
Bias stability	$\leq 6$ °/hour
Scale factor error	$\leq 1400$ ppm
Angular random walk	$\leq 0.3$ °/ $\sqrt{\text{hour}}$
<b>Accelerometer Performance</b>	
Input range	$\pm 15$ g
Bias repeatability	$\leq 3$ mg
Scale factor error	$\leq 1500$ ppm
Velocity random walk	$\leq 0.25$ mg/degree/ $\sqrt{\text{Hz}}$
<b>Data Rate</b>	
IMU Measurement	200 Hz

### A.9.3 IMU- $\mu$ IMU-IC Electrical and Environmental

**Table 93: IMU- $\mu$ IMU-IC Electrical Specifications**

Electrical	
IMU Power Consumption	11 W (typical)
IMU Input Voltage	+10 to +34 VDC
IMU Interface	RS-422
Connectors	
Power	SAL M12, 5 pin, male
Data	SAL M12, 5 pin, female
Wheel Sensor	SAL M12, 8 pin, male

**Table 94: IMU- $\mu$ IMU-IC Environmental Specifications**

Environmental	
Operating Temperature	-40°C to +55°C
Storage Temperature	-40°C to +80°C
Humidity	MIL-STD-810G(Ch1), Method 507.6
Random Vibe	MIL-STD-810G(Ch1), Method 514.7 (2.0 g)
Environment	MIL-STD-810G(Ch1), Method 512.6 IEC 60529 IP67

### A.9.4 IMU- $\mu$ IMU-IC Cables

#### IMU- $\mu$ IMU-IC Interface Cable

The IMU- $\mu$ IMU-IC uses the IMU Enclosure Interface Cable. Refer to *IMU Enclosure Interface Cable* on page 177 for details about this cable.

#### IMU- $\mu$ IMU-IC Power Cable

The IMU- $\mu$ IMU-IC uses the IMU Enclosure Power Cable. Refer to *IMU Enclosure Power Cable* on page 179 for details about this cable.

#### IMU- $\mu$ IMU-IC Wheel Sensor Cable

The IMU- $\mu$ IMU-IC uses the IMU Enclosure Wheel Sensor Cable. Refer to *IMU Enclosure Wheel Sensor Cable* on page 180 for details about this cable.



## A.10 LN-200 IMU (single-connector enclosure)

**Table 95: LN-200 IMU Physical Specifications**

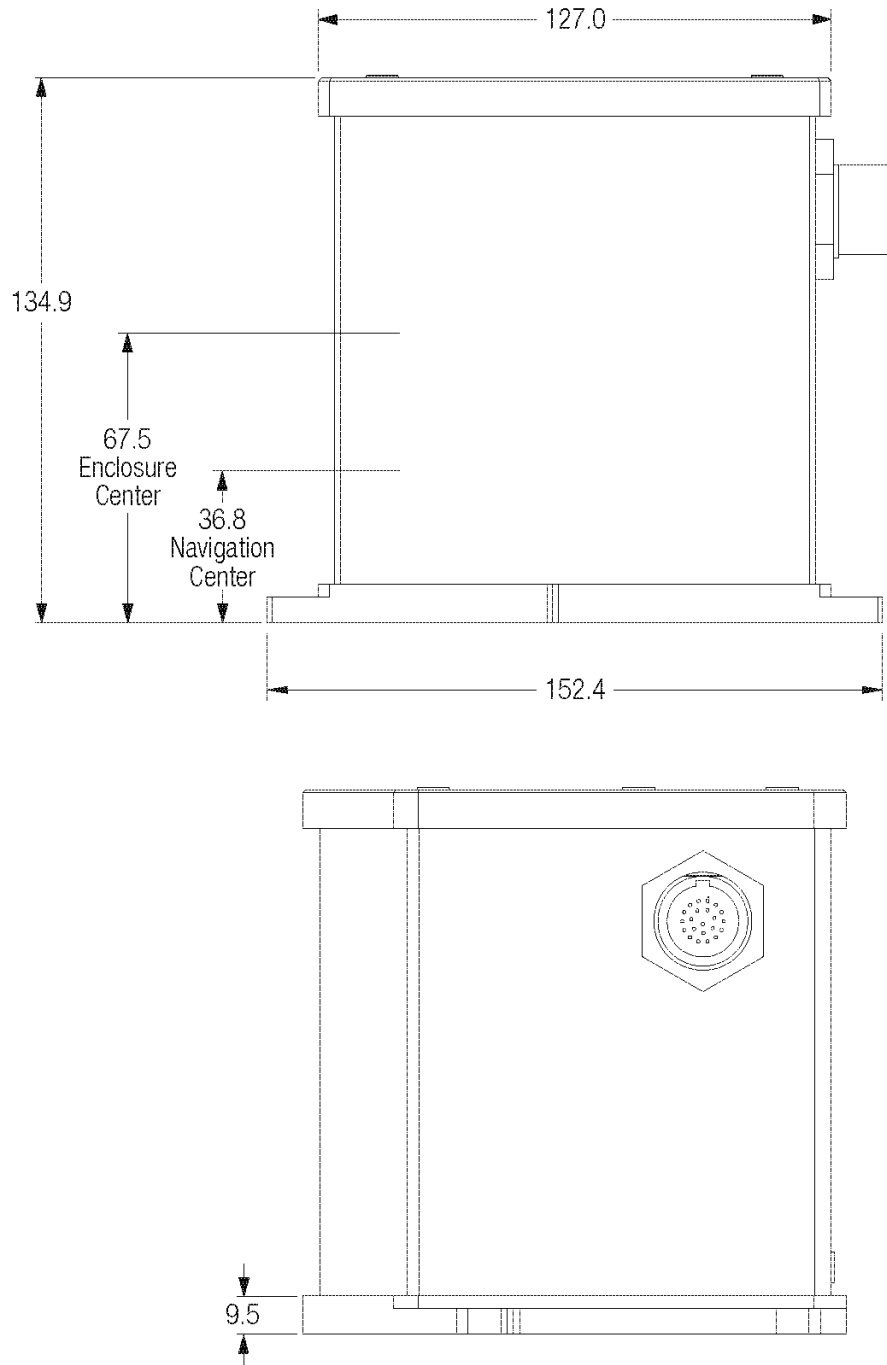
Physical	
IMU Enclosure Size	135 mm x 153 mm x 130 mm (5.315" x 6.024" x 5.118")
IMU Size	89 mm D x 85 mm H (3.504" D x 3.346" H)
IMU Weight	3.19 kg (7.02 lb.)

See the following sections for more information about the LN-200 IMU.

- *LN-200 IMU Mechanical Drawings* on the next page
- *LN-200 IMU Performance* on page 204
- *LN-200 Electrical and Environmental* on page 204
- *Interface Cable for the LN-200 IMU* on page 205



**Figure 70: LN-200 Enclosure Side Dimensions**



The Center of Navigation offsets, shown on the LN-200 label, are for the internal IMU and are different than for the enclosure center. The enclosure center is labelled as IMU Center in these figures. Dimensions are shown in millimeters.

**A.10.2 LN-200 IMU Performance****Table 96: LN-200 IMU Performance**

<b>Gyroscope Performance</b>	
Gyro Input Range	±1000 °/second
Gyro Rate Bias	1 °/hour
Gyro Rate Scale Factor	100 ppm
Angular Random Walk	0.07 °/√hour
<b>Accelerometer Performance</b>	
Accelerometer Range	±40 g
Accelerometer Linearity	150 ppm
Accelerometer Scale Factor	300 ppm
Accelerometer Bias	0.3 mg
<b>Data Rate</b>	
IMU Measurement	200 Hz

**A.10.3 LN-200 Electrical and Environmental****Table 97: LN-200 Electrical Specifications**

<b>Electrical</b>	
IMU Power Consumption	16 W (max)
IMU Input Voltage	+12 to +28 VDC
Receiver Power Consumption	1.8 W (typical)
System Power Consumption	13.8 W (typical)
Input/Output Connectors	MIL-C-38999-III, 22 pin (all IMUs)
IMU Interface	RS-232 or RS-422

**Table 98: LN-200 Environmental Specifications**

<b>Environmental (LN-200 IMU)</b>	
Operating Temperature	-30°C to +60°C (-22°F to 140°F)
Storage Temperature	-45°C to +80°C (-49°F to 176°F)
Humidity	95% non-condensing

#### **A.10.4 Interface Cable for the LN-200 IMU**

The IMU interface cable provides power to the IMU from an external power source and enables communication between the receiver and IMU. The LN-200 IMU uses the Universal IMU Enclosure Interface cable (see *Universal IMU Enclosure Interface Cable* on page 257).

## A.11 OEM-IMU-ADIS-16488



The OEM-IMU-ADIS-16488 requires a MEMS Interface Card (MIC) to connect to an OEM719 or OEM729 receiver. See *MIC - MEMS Interface Card* on page 259.

To connect the OEM-IMU-ADIS-16488 to an OEM7600, OEM7700 or OEM7720 receiver, you can use either a MIC or a direct connection via the SPI port.

**Table 99: OEM-IMU-ADIS-16488 Physical Specifications**

Physical	
IMU Size	47 mm x 44 mm x 14 mm
IMU Weight	48 g
IMU with mounting PCB size	71.1 mm x 45.7 mm x 17.6 mm

See the following sections for more information about the OEM-IMU-ADIS-16488.

- *OEM-IMU-ADIS-16488 Mechanical Drawings* on the next page
- *OEM-IMU-ADIS-16488 Sensor Specifications* on page 210
- *OEM-IMU-ADIS-16488 Electrical and Environmental* on page 210
- *OEM-IMU-ADIS-16488 SPI Connection* on page 211
- *ADIS-16488 IMU-to-MIC Cable Assembly* on page 213

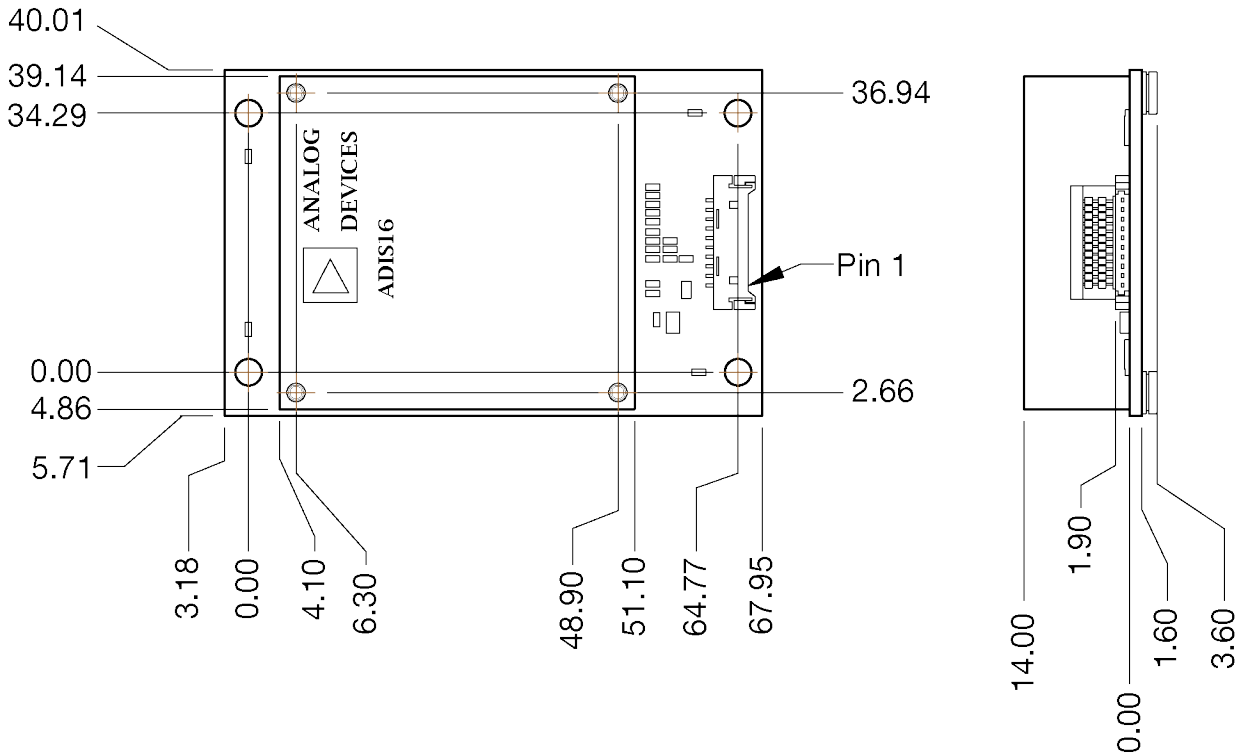
### A.11.1 OEM-IMU-ADIS-16488 Mechanical Drawings



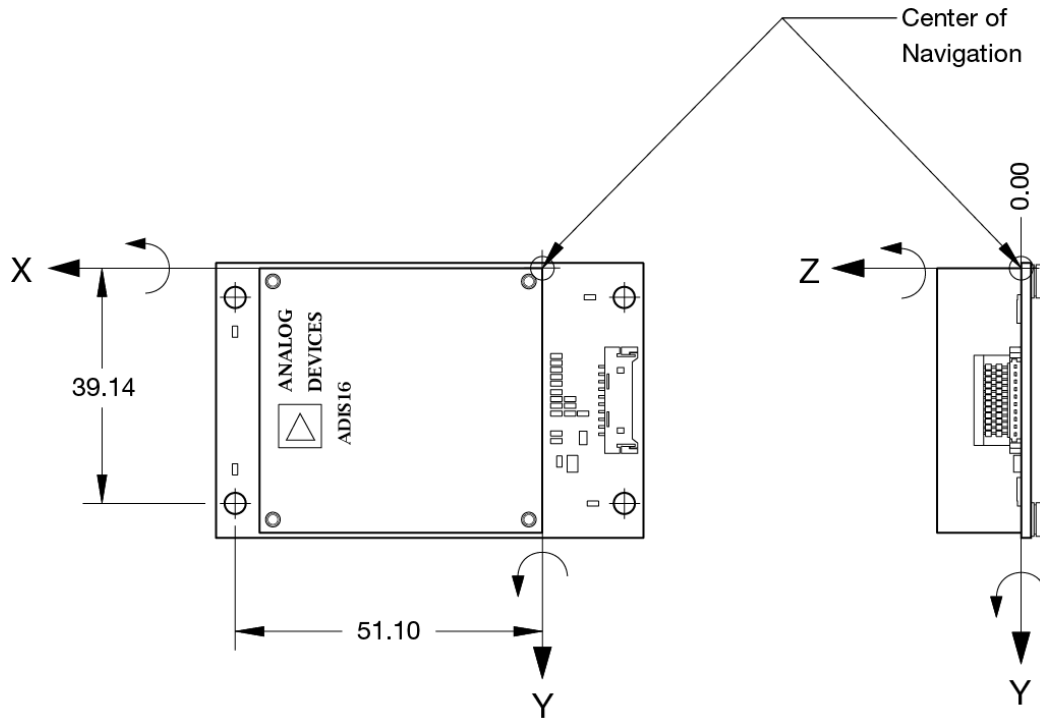
The dimensions in these drawings are in millimeters.

The following two drawings include the ADIS-16488 interface board. The ADIS-16488 with interface board is intended for use with a MIC.

**Figure 71: ADIS-16488 Dimensions**



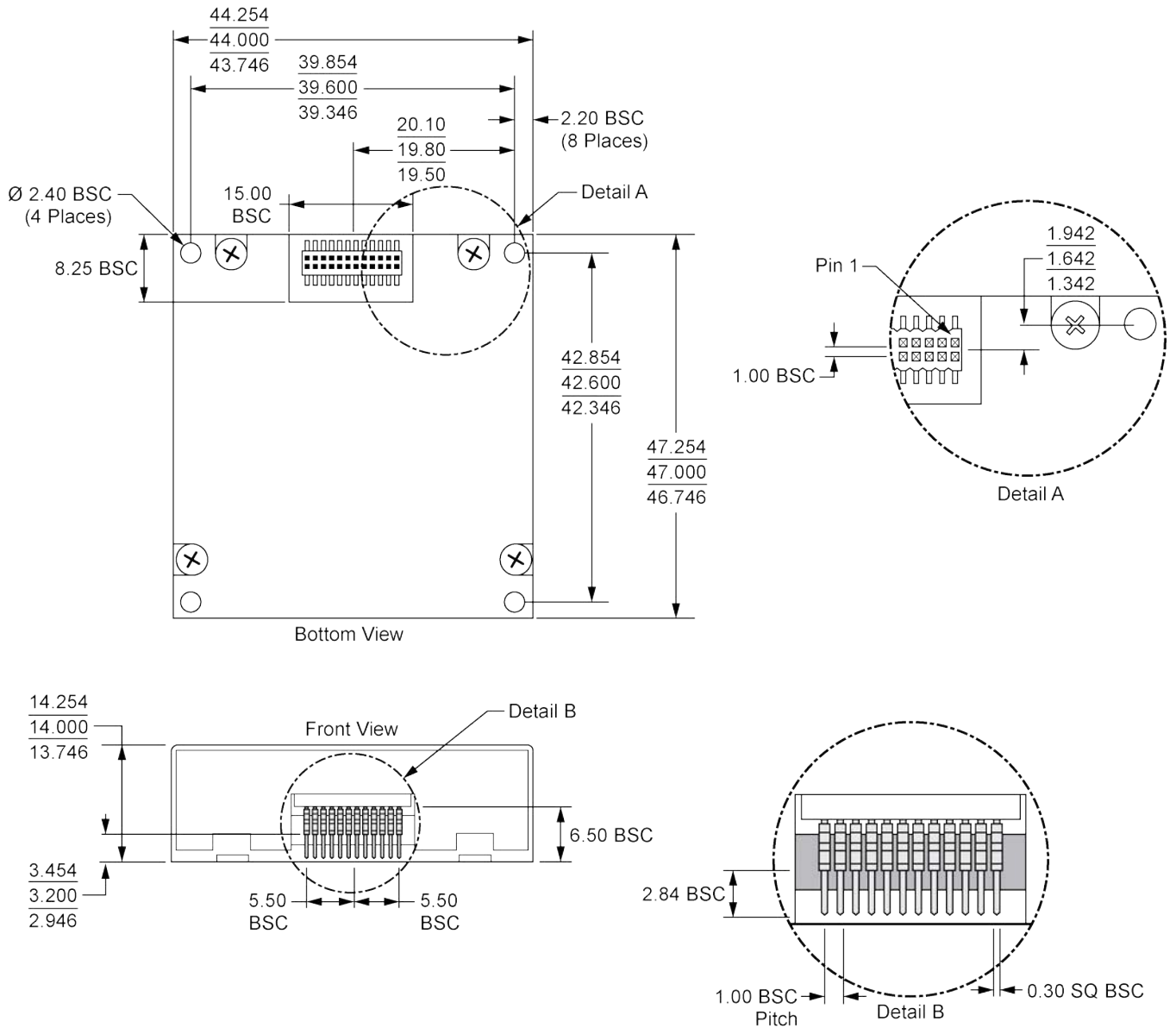
**Figure 72: ADIS-16488 Center of Navigation**



The following diagram shows the ADIS-16488 without the interface board. The ADIS-16488 without interface board is for applications where the IMU connects directly to the OEM7 receiver using a SPI port.



**Figure 73: OEM ADIS-16488 Dimensions**



### A.11.2 OEM-IMU-ADIS-16488 Sensor Specifications

Table 100: OEM-IMU-ADIS-16488 Performance

Gyroscope Performance	
Gyro Input Range	$\pm 450^\circ/\text{second}$
In-run Gyro Rate Bias Stability	$6.25^\circ/\text{hour}$
Angular Random Walk	$0.30^\circ/\sqrt{\text{hour}}$
Accelerometer Performance	
Accelerometer Range	$\pm 18 \text{ g}$
In-run Accelerometer Bias Stability	0.1 mg
Velocity Random Walk	$0.029 \text{ m/s}/\sqrt{\text{hour}}$
Data Rate	
IMU Measurement	200 Hz

### A.11.3 OEM-IMU-ADIS-16488 Electrical and Environmental

Table 101: OEM-IMU-ADIS-16488 Electrical Specifications

Electrical	
Input Power	+3.0 to + 3.6 VDC +3.3 VDC typical
Power consumption	254 mA typical
IMU Interface	SPI

Table 102: OEM-IMU-ADIS-16488 Environmental Specifications

Environmental	
Temperature, operational	$-40^\circ\text{C}$ to $+85^\circ\text{C}$
Temperature, non-operational	$-40^\circ\text{C}$ to $+105^\circ\text{C}$

### A.11.4 OEM-IMU-ADIS-16488 SPI Connection

The following table shows the connections required when connecting the OEM-IMU-ADIS-16488 IMU to a SPI compatible OEM7 receiver, such as the OEM7600, OEM7700 or OEM7720.

**Table 103: Receiver to ADIS-16488 Pin Connections**

ADIS-16488		Receiver		
Pin	Pin Name	Pin	Pin Name	Description
1	NC	–	–	Do not connect
2	NC	–	–	Do not connect
3	SCLK	44	SPI_SCLK	SPI Serial Clock
4	SDO	43	SPI_MISO	SPI Data Output
5	SDI	41	SPI_MOSI	SPI Data Input
6	/CS	42	SPI_nCS	SPI Chip Select
7	DIO1	26	EVENT_OUT2	Synchronization signal
8	/RST	–	–	<p>Reset IMU</p> <p>RST must be high for the IMU to be active.</p> <p>To enable the IMU when the receiver is powered on, connect this pin to Pin 1 or Pin 2 of the receiver interface connector through a 10 kΩ resistor (recommended).</p> <p>Can also connect this pin to any stable 3.3 VDC power supply or output configuration to have more control over when IMU is enabled. When using this configuration note that:</p> <ul style="list-style-type: none"> <li>pin 8 must be pulled low for greater than 100 ms to properly soft-reset the IMU</li> <li>pin has an internal pull-up resistor</li> </ul>
9	DIO2	29	EVENT_IN2	Data ready
10	VDD	–	–	3.3 VDC power supply
11	VDD	–	–	3.3 VDC power supply
12	VDD	–	–	3.3 VDC power supply
13	GND	–	–	Digital ground
14	GND	–	–	Digital ground
15	GND	–	–	Digital ground
16	NC	–	–	Do not connect

ADIS-16488		Receiver		
Pin	Pin Name	Pin	Pin Name	Description
17	NC	–	–	Do not connect
18	NC	–	–	Do not connect
19	NC	–	–	Do not connect
20	NC	–	–	Do not connect
21	NC	–	–	Do not connect
22	NC	–	–	Do not connect
23	NC	–	–	Do not connect
24	NC	–	–	Do not connect

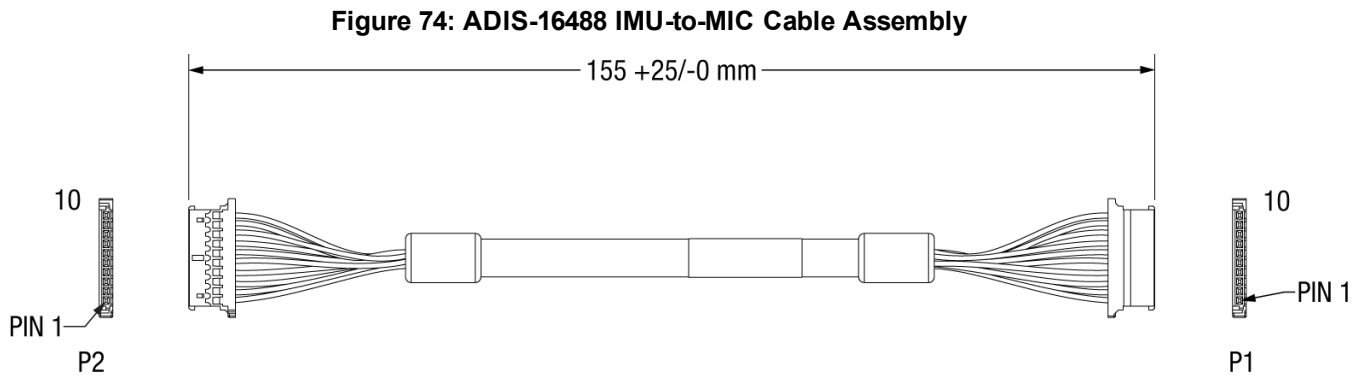


For the location of the receiver pins, refer to the [OEM7 Installation and Operation User Manual](#).

For more information about connecting using a SPI port, refer to *Connect an OEM-IMU-ADIS-16488 Directly to an OEM7 Receiver Card* on page 41.

### A.11.5 ADIS-16488 IMU-to-MIC Cable Assembly

The NovAtel part number for the ADIS-16488 IMU-to-MIC interface cable is 01019008 (*Figure 74: ADIS-16488 IMU-to-MIC Cable Assembly* below). This cable provides power to the IMU and enables communication between the MIC and the IMU.



**Table 104: ADIS-16488 IMU-to-MIC Cable Pinout**

P2 Pin	Signal Name	P1 Pin
1	IMU_VDD	1
2	IMU_VDD	2
3	SPI_NSS	3
4	SPI_CLK	4
5	Ground	5
6	SPI_MOSI	6
7	SPI_MISO	7
8	Ground	8
9	ADIS_IMU_DIO1	9
10	ADIS_IMU_DIO2	10

## A.12 OEM-IMU-EG320N


**Table 105: OEM-IMU-EG320N Physical Specifications**

Physical	
IMU Size	24 mm x 24 mm x 10 mm
IMU Weight	10 g

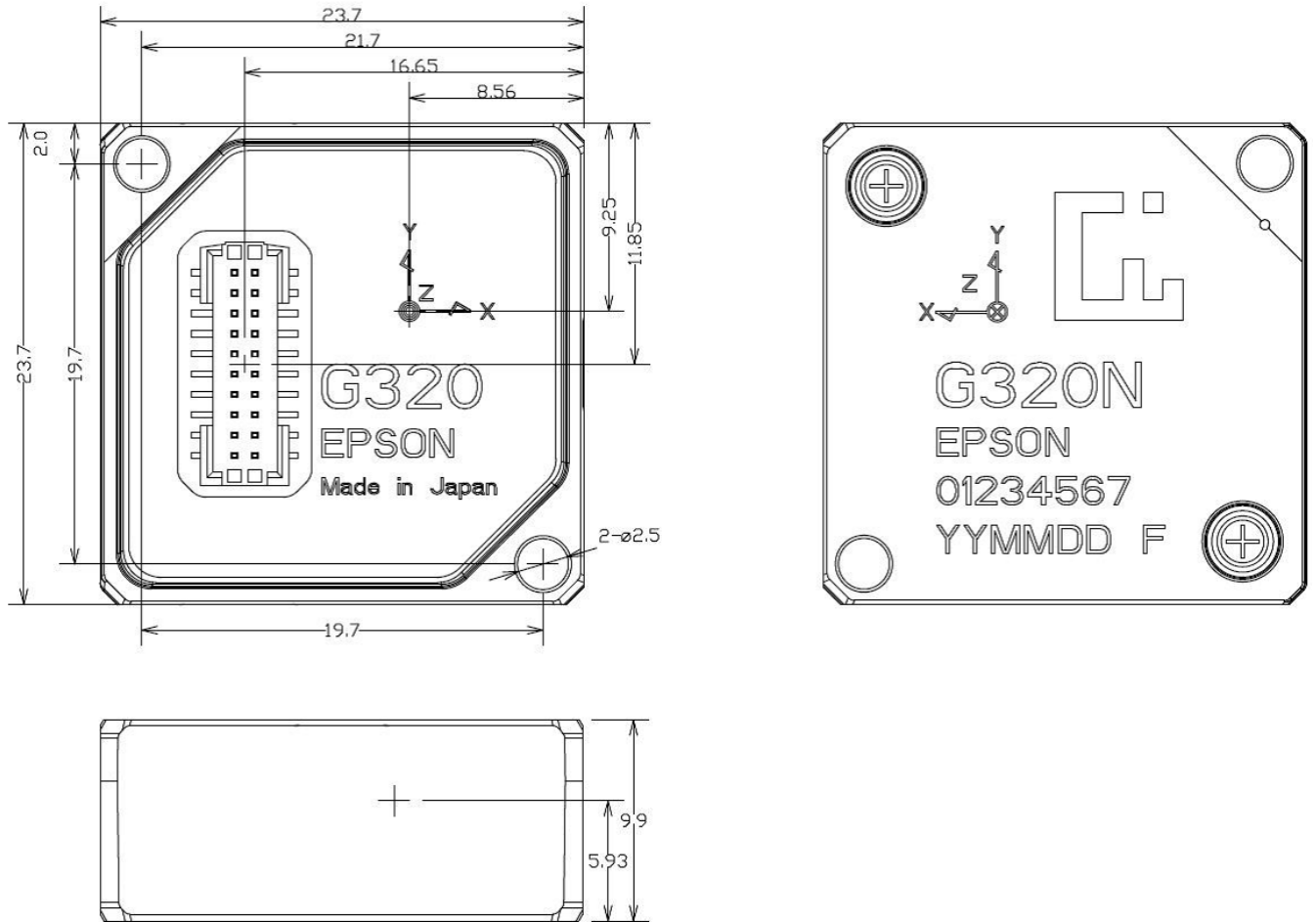
See the following sections for more information about the OEM-IMU-EG320N IMU.

- *OEM-IMU-EG320N Mechanical Drawings* on the next page
- *OEM-IMU-EG320N Sensor Specifications* on page 216
- *OEM-IMU-EG320N Electrical and Environmental* on page 216
- *OEM-IMU-EG320N Interface Connector* on page 217

**A.12.1 OEM-IMU-EG320N Mechanical Drawings**

 The following graphics are courtesy of Seiko Epson Corporation.  
In the following graphics, the dimensions are in millimeters.

**Figure 75: EG320N Dimensions**



### A.12.2 OEM-IMU-EG320N Sensor Specifications

**Table 106: OEM-IMU-EG320N Performance**

<b>Gyroscope Performance</b>	
Input Rate (max)	$\pm 150^\circ/\text{second}$
Bias Repeatability	$0.5^\circ/\text{second}$
Bias Instability	$3.5^\circ/\text{hour}$
Angular Random Walk	$0.1^\circ/\sqrt{\text{hour}}$
<b>Accelerometer Performance</b>	
Accelerometer Range	$\pm 5 \text{ g}$
Bias Repeatability	15 mg
Bias Instability	0.1 mg
Velocity Random Walk	$0.05 \text{ m/s}/\sqrt{\text{hour}}$
<b>Data rate</b>	
IMU Measurement	125 Hz 200 Hz

### A.12.3 OEM-IMU-EG320N Electrical and Environmental

**Table 107: OEM-IMU-EG320N Electrical Specifications**


<b>Electrical</b>	
Input Power	+3.15 to +3.45 VDC +3.3 VDC typical
Power consumption	0.1 W nominal

**Table 108: OEM-IMU-EG320N Environmental Specifications**

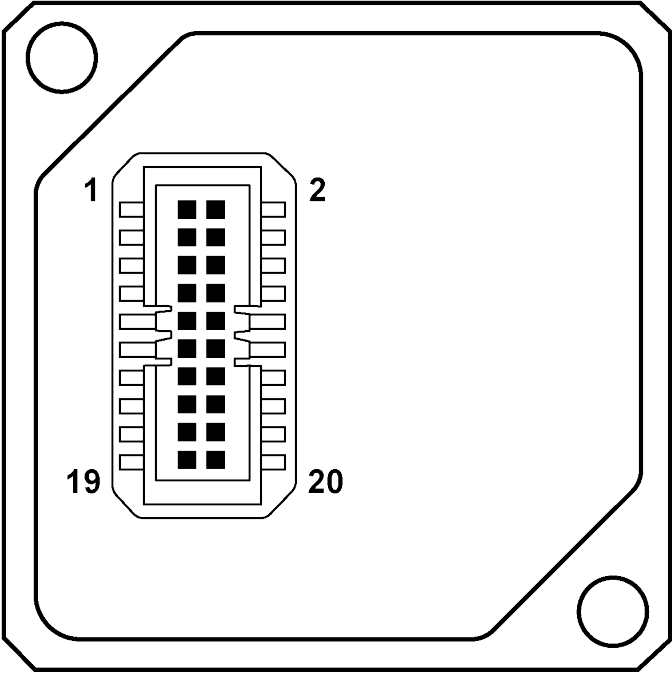
<b>Environmental</b>	
Temperature, operational	$-40^\circ\text{C}$ to $+85^\circ\text{C}$
Temperature, non-operational	$-40^\circ\text{C}$ to $+85^\circ\text{C}$
Vibration, operating	MIL-STD-810G, 7.7 g RMS, 20 - 2000 Hz
Shock, operating	MIL-STD-810G, 40 g, 11 ms
Shock, survival	1000 g, half sine, 0.5 ms



**A.12.4 OEM-IMU-EG320N Interface Connector**

 This graphic is courtesy of Seiko Epson Corporation.

**Figure 76: OEM-IMU-EG320N Pin Locations**



**Table 109: OEM-IMU-EG320N Connector**

Pin	Pin Name	Description
1	SCLK	SPI Serial Clock
2	SDO	SPI Data Output
3	GND	Digital ground
4	GND	Digital ground
5	SDI	SPI Data Input
6	/CS	SPI Chip Select
7*	SOUT	UART Data Out
8	GND	Digital ground
9*	SIN	UART Data In
10	VCC	3.3 VDC power supply
11	VCC	3.3 VDC power supply

Pin	Pin Name	Description
12	VCC	3.3 VDC power supply
13	DRDY(GPIO1)	Data Ready
14	GPIO2(EXT)	External Trigger
15	GND	Digital ground
16	/RST	Reset IMU RST must be high for the IMU to be active.
17	NC	Do not connect
18	NC	Do not connect
19	NC	Do not connect
20	NC	Do not connect



The IMU-OEM-EG320N requires a Samtec CLM-110-02-H-D mating connector.

## A.13 OEM-IMU-EG370N


**Table 110: OEM-IMU-EG370N Physical Specifications**

Physical	
IMU Size	24 mm x 24 mm x 10 mm
IMU Weight	10 g

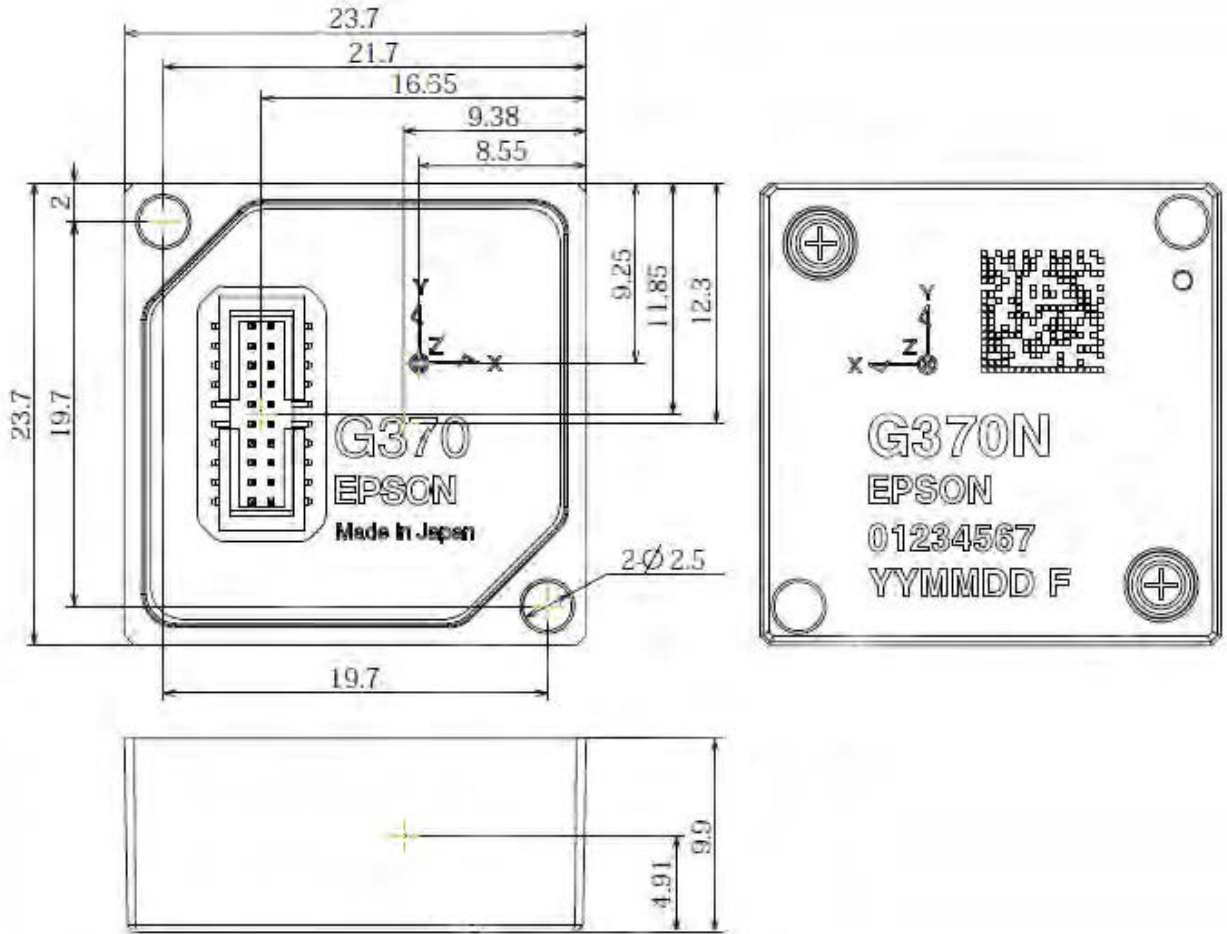
See the following sections for more information about the OEM-IMU-EG370N IMU.

- *OEM-IMU-EG370N Mechanical Drawings* on the next page
- *OEM-IMU-EG370N Sensor Specifications* on page 221
- *OEM-IMU-EG370N Electrical and Environmental* on page 221
- *OEM-IMU-EG370N Interface Connector* on page 222

**A.13.1 OEM-IMU-EG370N Mechanical Drawings**

 The following graphics are courtesy of Seiko Epson Corporation.  
In the following graphics, the dimensions are in millimeters.

**Figure 77: EG370N Dimensions**



### A.13.2 OEM-IMU-EG370N Sensor Specifications

**Table 111: OEM-IMU-EG370N Performance**

<b>Gyroscope Performance</b>	
Input Rate (max)	$\pm 450^\circ/\text{second}$
Rate bias stability	$0.8^\circ/\text{hour}$
Angular Random Walk	$0.06^\circ/\sqrt{\text{hour}}$
<b>Accelerometer Performance</b>	
Accelerometer Range	$\pm 10 \text{ g}$
Bias stability	$0.012 \text{ mg}$
Velocity Random Walk	$0.025 \text{ m/s}/\sqrt{\text{hour}}$
<b>Data rate</b>	
IMU Measurement	200 Hz

### A.13.3 OEM-IMU-EG370N Electrical and Environmental


**Table 112: OEM-IMU-EG370N Electrical Specifications**

<b>Electrical</b>	
Input Power	+3.15 to +3.45 VDC +3.3 VDC typical
Power consumption	0.1 W nominal

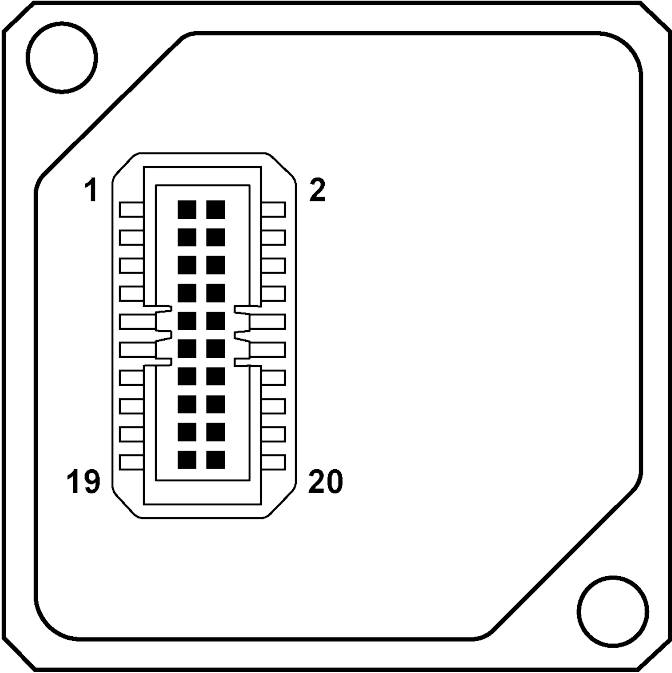
**Table 113: OEM-IMU-EG370N Environmental Specifications**

<b>Environmental</b>	
Temperature, operational	$-40^\circ\text{C}$ to $+85^\circ\text{C}$
Temperature, non-operational	$-40^\circ\text{C}$ to $+85^\circ\text{C}$
Vibration, operating	MIL-STD-810G, 7.7 g RMS, 20 - 2000 Hz
Shock, operating	MIL-STD-810G, 40 g, 11 ms
Shock, survival	1000 g, half sine, 0.5 ms

**A.13.4 OEM-IMU-EG370N Interface Connector**

 This graphic is courtesy of Seiko Epson Corporation.

**Figure 78: OEM-IMU-EG370N Pin Locations**



**Table 114: OEM-IMU-EG370N Connector**

Pin	Pin Name	Description
1	SCLK	SPI Serial Clock
2	SDO	SPI Data Output
3	GND	Digital ground
4	GND	Digital ground
5	SDI	SPI Data Input
6	/CS	SPI Chip Select
7*	SOUT	UART Data Out
8	GND	Digital ground
9*	SIN	UART Data In
10	VCC	3.3 VDC power supply

Pin	Pin Name	Description
11	VCC	3.3 VDC power supply
12	VCC	3.3 VDC power supply
13	DRDY(GPIO1)	Data Ready
14	GPIO2(EXT)	External Trigger
15	GND	Digital ground
16	/RST	Reset IMU RST must be high for the IMU to be active.
17	NC	Do not connect
18	NC	Do not connect
19	NC	Do not connect
20	NC	Do not connect



The IMU-OEM-EG370N requires a Samtec CLM-110-02-H-D mating connector.

## A.14 OEM-IMU-HG4930

**Table 115: OEM-IMU-HG4930 Physical Specifications**

Physical	
IMU Size	64.8 mm diameter × 35.7 mm height
IMU Weight	200 g

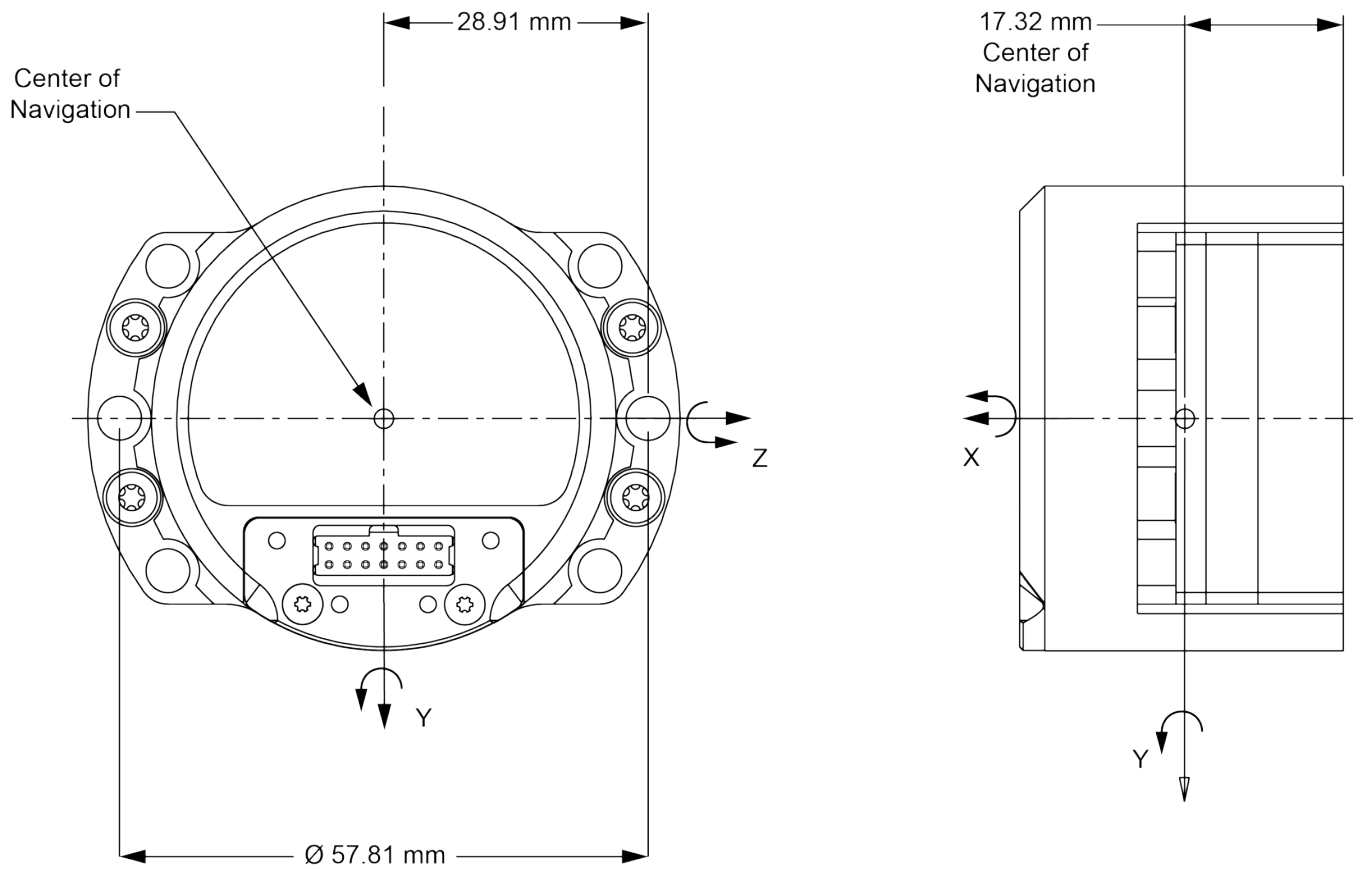
See the following sections for information about the OEM-IMU-HG4930 IMU.

- *OEM-IMU-HG4930 Mechanical Drawings* on the next page
- *OEM-IMU-HG4930 Sensor Specifications* on page 226
- *OEM-IMU-HG4930 Electrical and Environmental* on page 226
- *OEM-IMU-HG4930 Interface Connector* on page 227



**A.14.1 OEM-IMU-HG4930 Mechanical Drawings**

**Figure 79: OEM-IMU-HG4930 Center of Navigation**



For additional mechanical drawings, visit the Honeywell Aerospace website ([aerospace.honeywell.com](http://aerospace.honeywell.com)).

**A.14.2 OEM-IMU-HG4930 Sensor Specifications**

**Table 116: OEM-IMU-HG4930 Performance**

<b>Gyroscope Performance</b>	
Technology	MEMS
Gyro Input Range	±200°/second
<b>Accelerometer Performance</b>	
Technology	MEMS
Accelerometer Range	±20 g
<b>Data rate</b>	
IMU Measurement	100 Hz

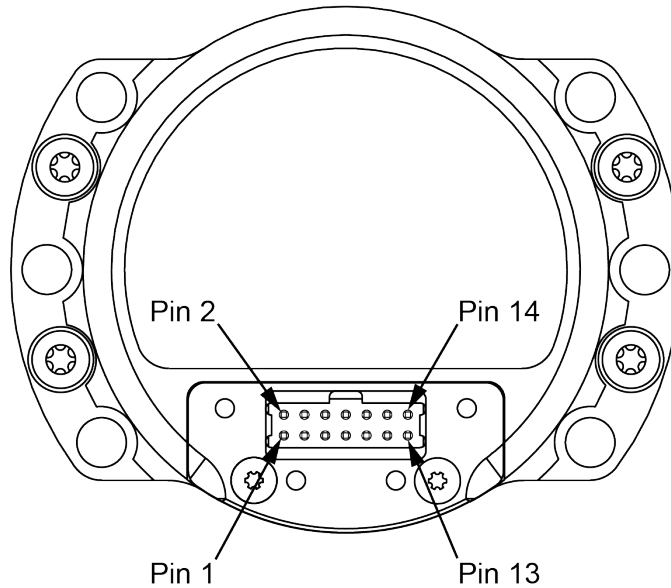
**A.14.3 OEM-IMU-HG4930 Electrical and Environmental**

**Table 117: OEM-IMU-HG4930 Electrical Specifications**

<b>Electrical</b>	
Input Power	+5.0 VDC
Power consumption	<3 W typical
Connector	14 pin header

**Table 118: OEM-IMU-HG4930 Environmental Specifications**

<b>Environmental</b>	
Temperature, operational	-40°C to +71°C
Temperature, non-operational	-40°C to +80°C
Random vibration	MIL-STD-810G(Ch1), Method 514.7 (2.0g)

**A.14.4 OEM-IMU-HG4930 Interface Connector****Table 119: OEM-IMU-HG4930 Connector**

Pin	Pin Name	Description
1	GND	Ground
2	+5V	+5 VDC power supply input
3	TMI	Timing input
4	No connect	No connect
5	No connect	No connect
6	Reserved	Reserved
7	No connect	No connect
8	No connect	No connect
9	SER_DATA_OUT_H	Serial Data High Output (RS-485)
10	SER_DATA_OUT_L	Serial Data Low Output (RS-485)
11	TTL_TX	Transmit data (RS-232) Serial communication port
12	TTL_RX	Receive data (RS-232) Serial communication port
13	No connect	No connect
14	No connect	No connect

## A.15 OEM-IMU-ISA-100C



The OEM-IMU-ISA-100C requires a Universal IMU Controller Card to connect to a NovAtel receiver. See *UIC - Universal IMU Controller* on page 272.


**Table 120: OEM-IMU-ISA-100C Physical Specifications**

Physical	
IMU Size	100 mm x 130 mm x 125 mm
IMU Weight	2 kg

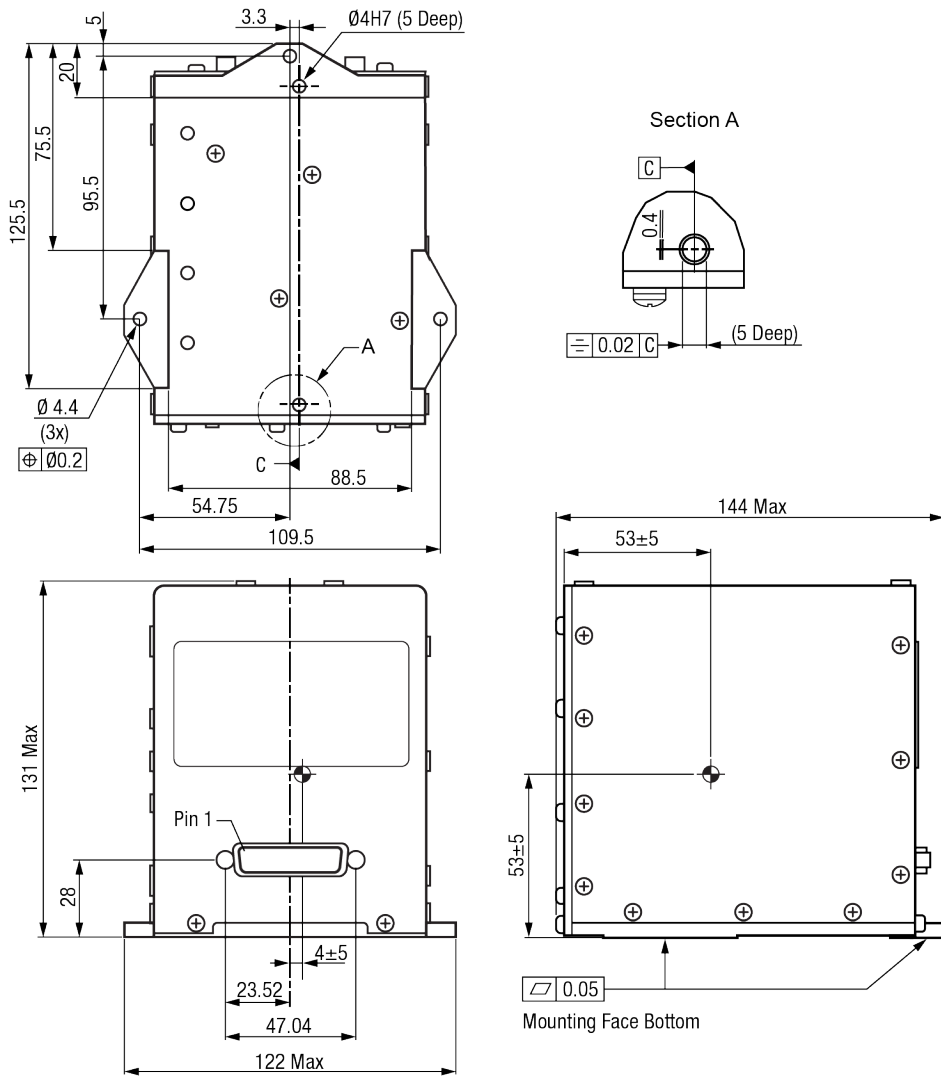
See the following sections for more information about the OEM-IMU-ISA-100C IMU.

- *OEM-IMU-ISA-100C Mechanical Drawings* on the next page
- *OEM-IMU-ISA-100C Sensor Specifications* on page 231
- *OEM-IMU-ISA-100C Electrical and Environmental* on page 231
- *OEM-IMU-ISA-100C IMU to UIC Cable Assembly* on page 232

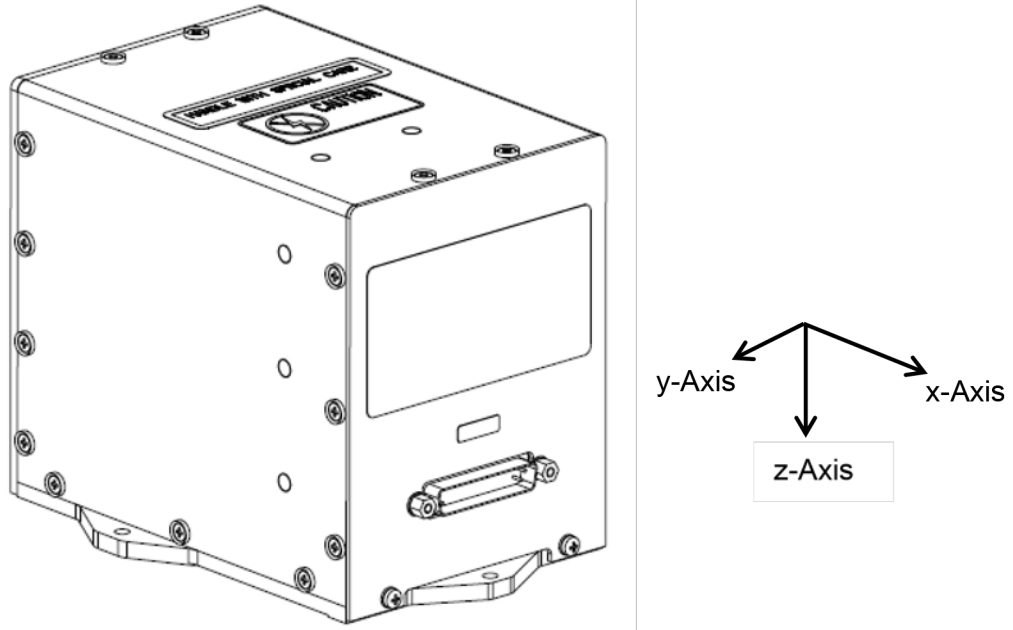
**A.15.1 OEM-IMU-ISA-100C Mechanical Drawings**

 The following graphics are courtesy of Northrop Grumman LITEF GmbH.  
The dimensions in the following graphics are in millimeters.

**Figure 80: ISA-100C Dimensions**



**Figure 81: ISA-100C Coordinate Axis**



**A.15.2 OEM-IMU-ISA-100C Sensor Specifications**

**Table 121: OEM-IMU-ISA-100C IMU Performance**

<b>Gyroscope Performance</b>	
Input range	±495 °/seconds
In-run bias stability	≤0.05 °/hour
Scale factor repeatability	≤100 ppm
Scale factor non-linearity	≤100 ppm
Angular random walk	0.012 °/√hour
<b>Accelerometer Performance</b>	
Range	±10 g
In-run bias stability	≤100 µg
1 year scale factor repeatability	≥1250 ppm
Scale factor non-linearity	≤100 ppm
Velocity random walk	≤100 µg/√Hz
<b>Data Rate</b>	
IMU Measurement	200 Hz

**A.15.3 OEM-IMU-ISA-100C Electrical and Environmental**

**Table 122: OEM-IMU-ISA-100C Electrical Specifications**

<b>Electrical</b>	
Input Power	+3.3 V, ±5.25 V, ±15 V, -15 V (optional)
Power consumption	≤10 W (typical) 16 W (maximum)
Connector	44 pin HD D-Sub, male

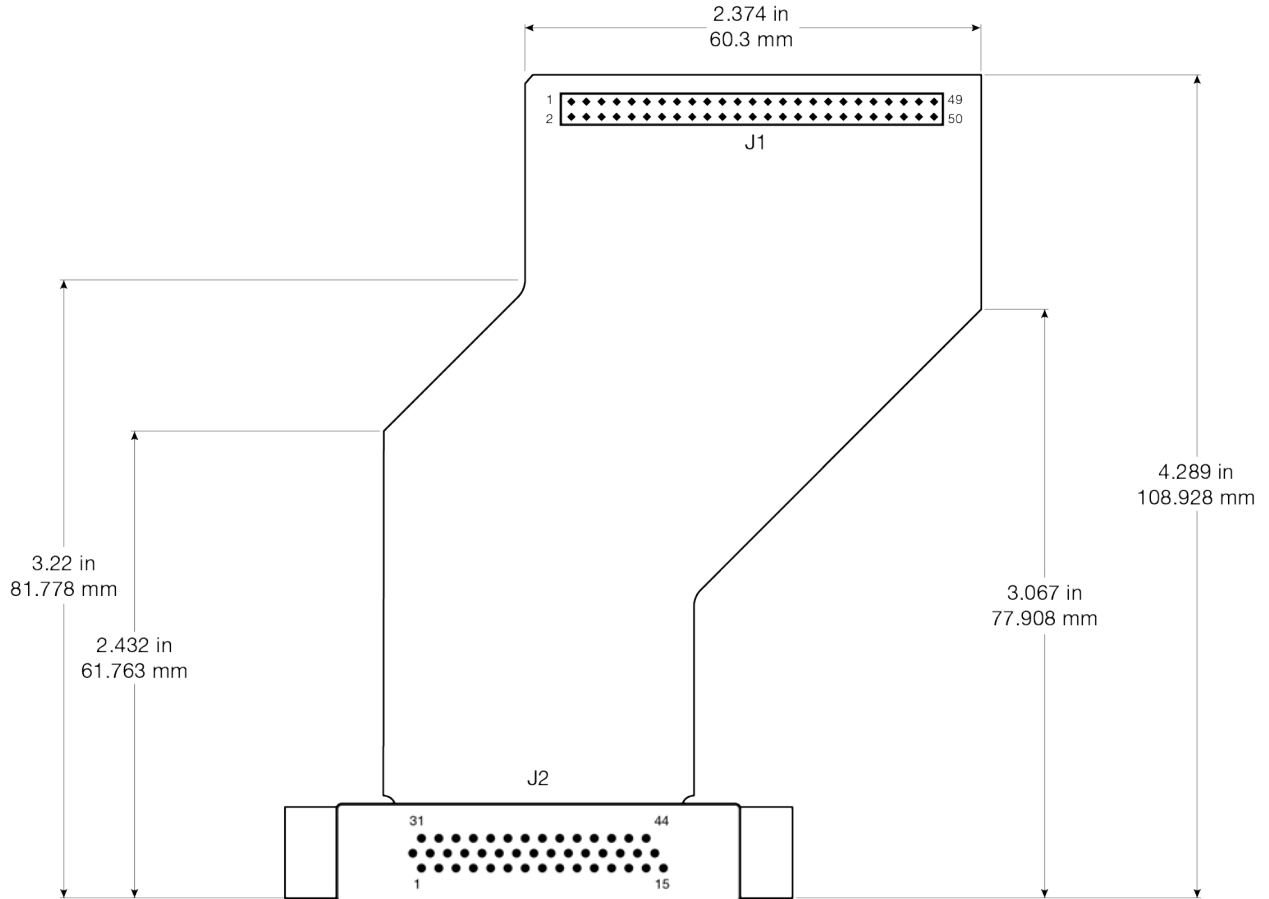
**Table 123: OEM-IMU-ISA-100C Environmental Specifications**

<b>Environmental</b>	
Temperature, operational	-40°C to +71°C

### A.15.4 OEM-IMU-ISA-100C IMU to UIC Cable Assembly

The NovAtel part number for the OEM-IMU-ISA-100C IMU to UIC interface cable is 01019393 (*Figure 82: OEM-IMU-ISA-100C IMU to UIC Cable Assembly* below). This cable provides power to the IMU and enables communication between the UIC and the IMU.

**Figure 82: OEM-IMU-ISA-100C IMU to UIC Cable Assembly**



**Table 124: OEM-IMU-ISA-100C IMU to UIC Cable Pin-out**

J2 Pin (ISA-100C)	Signal	J1 Pin (UIC)
1	GND	9
2	3.3 V	1
3	GND	4
4	GND	5
5	GND	6
6	GND	8



J2 Pin (ISA-100C)	Signal	J1 Pin (UIC)
7	GND	10
8	GND	15
9	GND	16
10	GND	21
11	GND	22
12	5.25 V	43
13	-5.25 V	49
14	-5.25 V	50
15	-5.25 V	
16	15 V	7
17	3.3 V	3
18	GND	28
19	–	–
20	–	–
21	NOGOx	18
22	–	–
23	GND	29
	GND	35
24	TXC+	32
25	SYNC-	34
26	GND	41
27	TXD+	40
28	–	–
29	GND	42
30	5.25 V	44
31	3.3 V	2
32	3.3 V	
33	PWRDOWNx	12

---

J2 Pin (ISA-100C)	Signal	J1 Pin (UIC)
34	RESETIMUx	14
35	–	–
36	GND	45
37	–	–
38	TXC-	30
39	GND	48
40	SYNC+	36
41	TXD-	38
42	–	–
43	GND	48
44	5.25 V	46

## A.16 OEM-IMU-STIM300



The OEM-IMU-STIM300 can use a MEMS Interface Card (MIC) or a direct RS-422 link to connect to an OEM7 receiver.

For information about using a MIC, see *MIC - MEMS Interface Card* on page 259.

For information about using a direct RS-422 link, see *Connect an OEM-IMU-STIM300 Directly to an OEM7 Receiver* on page 46.


**Table 125: OEM-IMU-STIM300 Physical Specifications**

Physical	
IMU Size	45 mm x 39 mm x 22 mm
IMU Weight	55 g

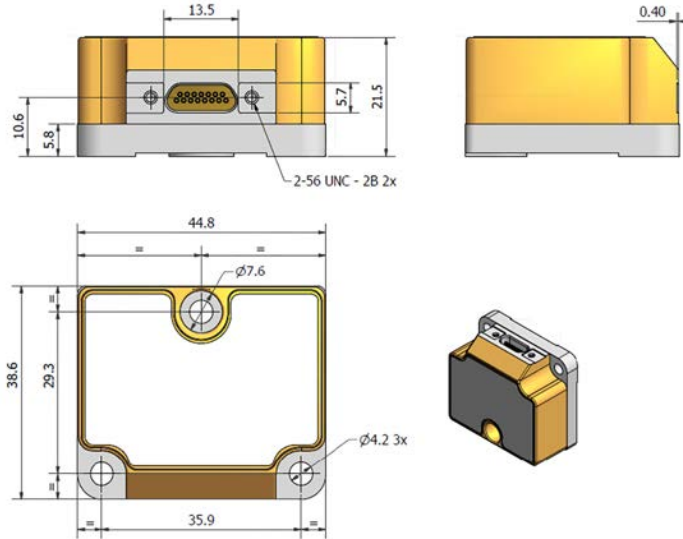
See the following sections for more information about the OEM-IMU-STIM300 IMU.

- *OEM-IMU-STIM300 Mechanical Drawings* on the next page
- *OEM-IMU-STIM300 Sensor Specifications* on page 237
- *OEM-IMU-STIM300 Electrical and Environmental* on page 237
- *OEM-IMU-STIM300 Direct Connection* on page 238
- *STIM300 IMU-to-MIC Cable Assembly* on page 241

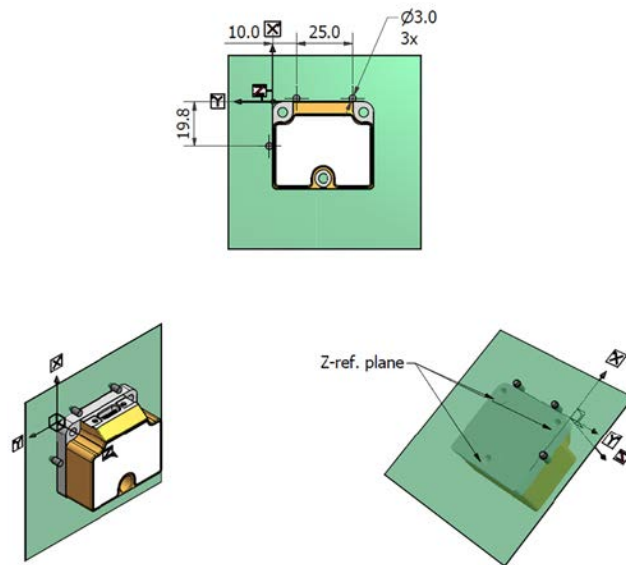
**A.16.1 OEM-IMU-STIM300 Mechanical Drawings**

 The following graphics are courtesy of Sensoror AS.  
In the following graphics, the dimensions are in millimeters.

**Figure 83: STIM300 Dimensions**



**Figure 84: STIM300 Center of Navigation**



**A.16.2 OEM-IMU-STIM300 Sensor Specifications****Table 126: OEM-IMU-STIM300 Performance**

<b>Gyroscope Performance</b>	
Gyro Input Range	±400°/second
In-run Gyro Rate Bias Stability	0.5°/hour
Angular Random Walk	0.15°/√hour
<b>Accelerometer Performance</b>	
Accelerometer Range	±10 g
In-run Accelerometer Bias Stability	0.05 mg
Velocity Random Walk	0.07 m/s/√hour
<b>Data rate</b>	
IMU Measurement	125 Hz

**A.16.3 OEM-IMU-STIM300 Electrical and Environmental****Table 127: OEM-IMU-STIM300 Electrical Specifications**

<b>Electrical</b>	
Input Power	+4.5 to +5.5 VDC +5.0 VDC typical
Power consumption	1.5 W nominal
Connector	15 pin Micro-D, female


**Table 128: OEM-IMU-STIM300 Environmental Specifications**

<b>Environmental</b>	
Temperature, operational	-40°C to +85°C
Temperature, non-operational	-55°C to +90°C

**A.16.4 OEM-IMU-STIM300 Direct Connection**


The following table shows the connections required when connecting the OEM-STIM300 to an OEM7 receiver using a RS-422 link.

**Table 129: OEM7 Receiver Card to STIM300 Pin Connections**

STIM300		RS-422 Line Driver		Receiver	
Pin	Pin Name	Output	Input	Pin Name	Description
1	STIM TXD-	RS422 B-	–	–	Part of RS-422 transmit pair from STIM300
2	STIM RxD-	RS422 A-	–	–	Part of RS-422 receive pair from STIM300
3	NC	–	–	–	Do not connect
4	STIM TOV	–	–	EVENT_IN2 OEM719: 7 OEM729: 7 OEM7600 : 29 OEM7700: 29 OEM7720: 29	<div style="border: 1px solid black; padding: 5px;">  <p><b>Interface Circuit Required</b> The STIM TOV output uses 5V logic, but the OEM7 EVENT_IN lines are not 5V tolerant. A circuit to convert from 5V logic to 3.3V levels is required.</p> </div>
5	NC	–	–	–	Do not connect
6	NC	–	–	–	Do not connect
7	NC	–	–	–	Do not connect
8	5V Pwr	–	–	–	5 VDC power supply
9	STIM TxD+	RS422 B+	–	–	Part of RS-422 transmit pair from STIM300
10	STIM RxD+	RS422 A+	–	–	Part of RS-422 receive pair from STIM300
11	NC	–	–	–	Do not connect
12	GND	–	–	–	Any receiver ground pin
13	GND	–	–	–	Any receiver ground pin
14	NC	–	–	–	Do not connect
15	GND	–	–	–	Any receiver ground pin

STIM300		RS-422 Line Driver		Receiver	
Pin	Pin Name	Output	Input	Pin Name	Description
–	–	–	LVCMOS A IN	COMx_TXD	Any receiver COM port transmit and receive pair
–	–	–	LVCMOS B IN	COMx_RXD	
–	–	–	GND		Any receiver ground pin

**Table 130: OEM729 COM1 or PwrPak7 to STIM300 Pin Connections**

STIM300		Receiver		Description
Pin	Pin Name	Pin	Pin Name	
1	STIM TXD-	OEM729 COM1: 15 PwrPak7 COM1: 4 COM2: 12	COMx_ RXD-	Part of RS-422 transmit pair from STIM300
2	STIM RxD-	OEM729 COM1: 17 PwrPak7 COM1: 1 COM2: 19	COMx_ TXD-	Part of RS-422 receive pair from STIM300
3	NC	–	–	Do not connect
4	STIM TOV	OEM729: 7 PwrPak7: 23	EVENT_IN2	<div style="border: 1px solid black; padding: 5px; margin-bottom: 5px;">  <p><b>Interface Circuit Required</b> The STIM TOV output uses 5V logic, but the OEM729 EVENT_IN lines are not 5V tolerant. A circuit to convert from 5V logic to 3.3V levels is required on the OEM729.</p> </div> <p>The PwrPak7 input strobes are 5V tolerant and can be connected directly to the STIM TOV output.</p>
5	NC	–	–	Do not connect
6	NC	–	–	Do not connect
7	NC	–	–	Do not connect
8	5V Pwr	–	–	5 VDC power supply

STIM300		Receiver		
Pin	Pin Name	Pin	Pin Name	Description
9	STIM TxD+	OEM729 COM1: 18 PwrPak7 COM1: 3 COM2: 20	COMx_ RXD+	Part of RS-422 transmit pair from STIM300
10	STIM RxD+	OEM729 COM1: 20 PwrPak7 COM1: 2 COM2: 10	COMx_ TXD+	Part of RS-422 receive pair from STIM300
11	NC	–	–	Do not connect
12	GND			Any receiver ground pin
13	GND			Any receiver ground pin
14	NC	–	–	Do not connect
15	GND			Any receiver ground pin



For the location of the receiver ground pins and transmit and receive pairs, refer to the [OEM7 Installation and Operation User Manual](#) or [PwrPak7 Installation and Operation User Manual](#).

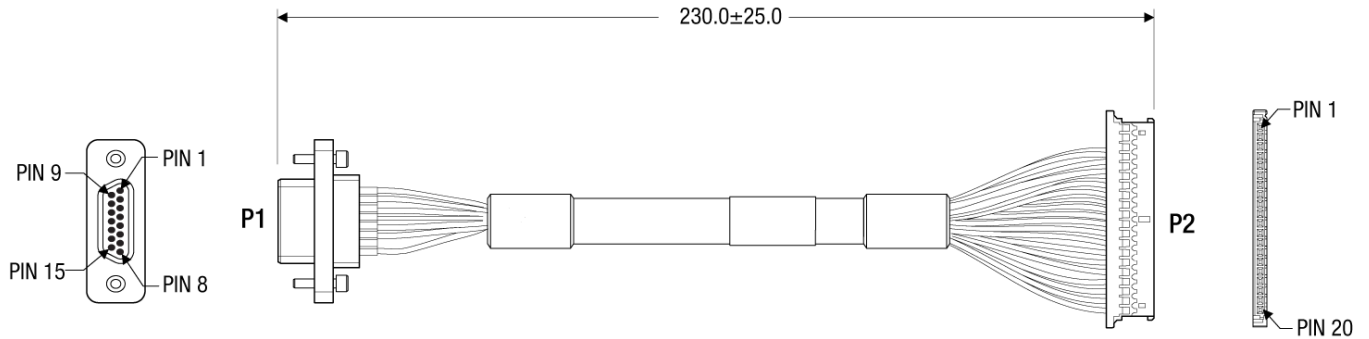
For more information about connecting using a SPI port, refer to *Connect an OEM-IMU-STIM300 Directly to an OEM7 Receiver* on page 46.



### A.16.5 STIM300 IMU-to-MIC Cable Assembly

The NovAtel part number for the STIM300 IMU-to-MIC interface cable is 01019161 (*Figure 85: STIM300 IMU-to-MIC Cable Assembly* below). This cable provides power to the IMU and enables communication between the MIC and the IMU.

**Figure 85: STIM300 IMU-to-MIC Cable Assembly**



The dimensions in this drawing are in millimeters.

**Table 131: STIM300 IMU-to-MIC Cable Pinout**

P2 Pin (MIC)	Signal	P1 Pin (STIM300)
1	No connection	–
2	No connection	–
3	No connection	–
4	No connection	–
5	No connection	–
6	Ground	12
7	Ground	13
8	VSUP (5V input)	8
9	VSUP (5V input)	
10	Ground	15
11	Transmit Data+	10
12	Transmit Data-	2
13	Receive Data+	9
14	Receive Data-	1
15	No connection	–

<b>P2 Pin (MIC)</b>	<b>Signal</b>	<b>P1 Pin (STIM300)</b>
16	No connection	–
17	IMU DAS	4
18	No connection	–
19	IMUTYPE1	15
20	No connection	–

## A.17 OEM-IMU- $\mu$ IMU



The OEM-IMU- $\mu$ IMU requires a Universal IMU Controller to connect to a NovAtel receiver. See *UIC - Universal IMU Controller* on page 272.

**Table 132: OEM-IMU- $\mu$ IMU Physical Specifications**

Physical	
IMU Size ( $\varnothing$ x H)	85 mm x 60 mm
IMU Weight	0.68 kg

See the following sections for more information about the OEM-IMU- $\mu$ IMU.

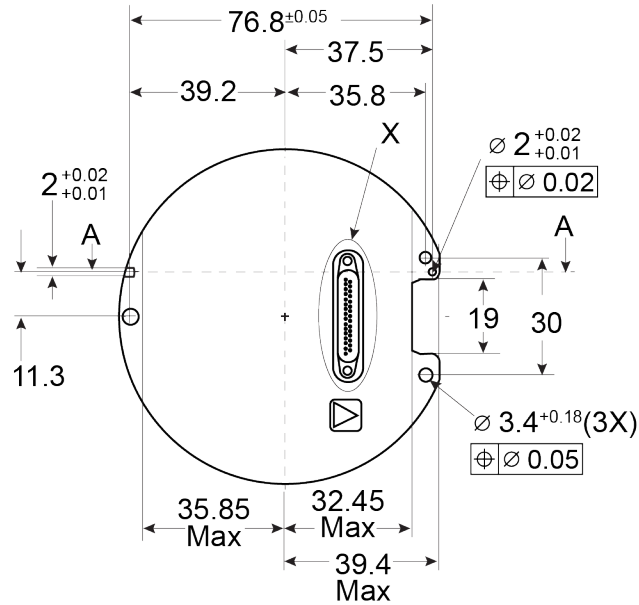
- *OEM-IMU- $\mu$ IMU Mechanical Drawings* on the next page
- *OEM-IMU- $\mu$ IMU Sensor Specifications* on page 246
- *OEM-IMU- $\mu$ IMU Electrical and Environmental* on page 246
- *$\mu$ IMU to UIC Cable Assembly* on page 247

**A.17.1 OEM-IMU- $\mu$ IMU Mechanical Drawings**

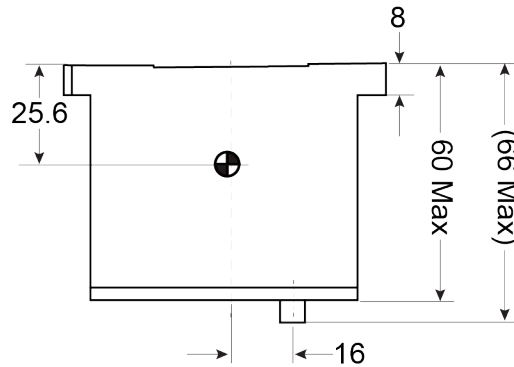


The following graphics are courtesy of Northrop Grumman LITEF GmbH.  
The dimensions in the following graphics are in millimeters.

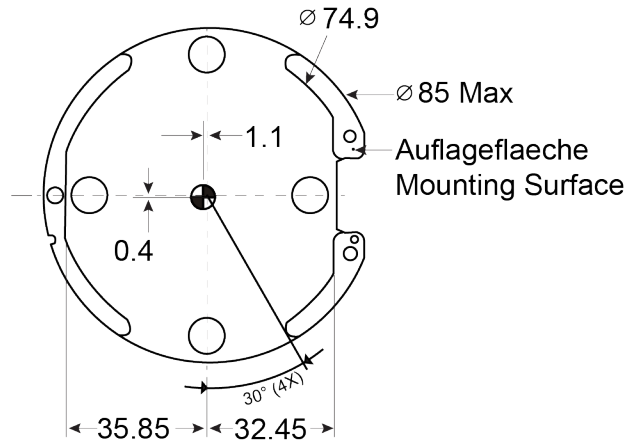
**Figure 86:  $\mu$ IMU Top Dimensions**



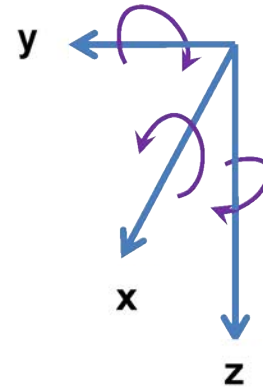
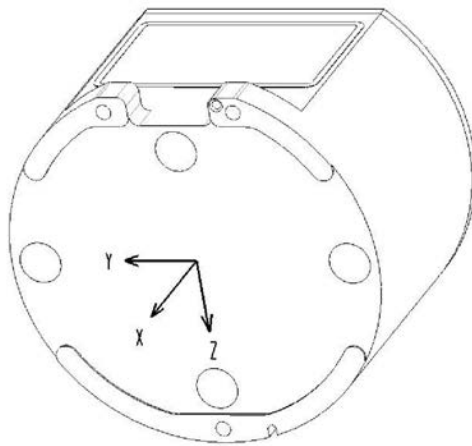
**Figure 87:  $\mu$ IMU Side Dimensions**



**Figure 88:  $\mu$ IMU Bottom Dimensions**



**Figure 89:  $\mu$ IMU Coordinate Axis**



Arrows indicate positive values.

**A.17.2 OEM-IMU- $\mu$ IMU Sensor Specifications**

**Table 133: OEM-IMU- $\mu$ IMU IMU Performance**

<b>Gyroscope Performance</b>	
Input range	$\pm 499$ °/second
Bias stability	$\leq 6$ °/hour
Scale factor error	$\leq 1400$ ppm
Angular random walk	$\leq 0.3$ °/ $\sqrt{\text{hour}}$
<b>Accelerometer Performance</b>	
Input range	$\pm 15$ g
Bias repeatability	$\leq 3$ mg
Scale factor error	$\leq 1500$ ppm
Velocity random walk	$\leq 0.25$ mg/degree/ $\sqrt{\text{Hz}}$
<b>Data Rate</b>	
IMU Measurement	200 Hz

**A.17.3 OEM-IMU- $\mu$ IMU Electrical and Environmental**

**Table 134: OEM-IMU- $\mu$ IMU Electrical Specifications**

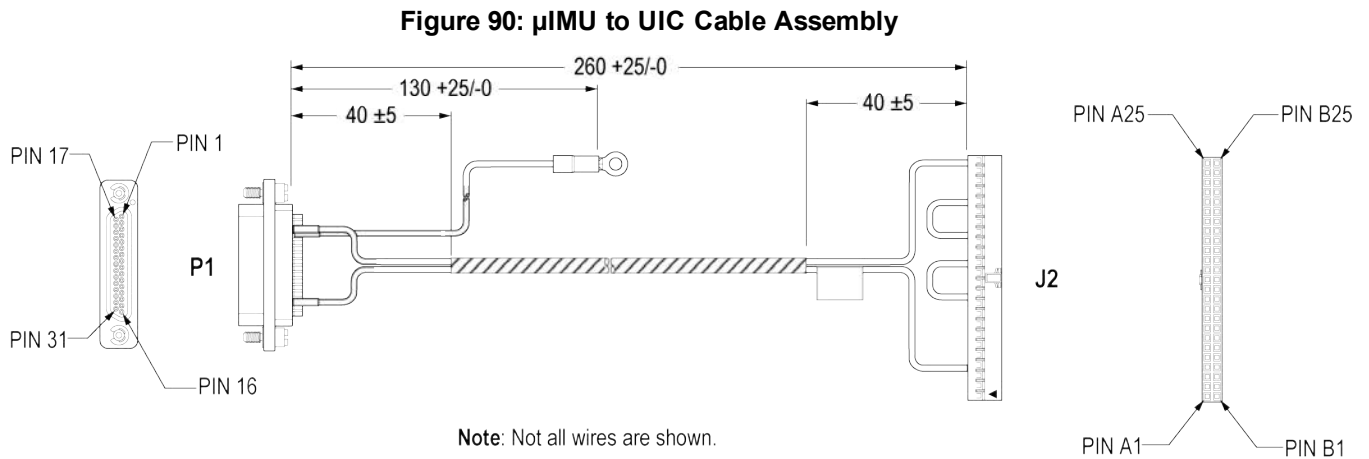
<b>Electrical</b>	
Input Power	+5.0 VDC
Power consumption	<8 W
Connector	31 pin Micro-D, plug

**Table 135: OEM-IMU- $\mu$ IMU Environmental Specifications**

<b>Environmental</b>	
Temperature, operational	-55°C to +71°C

### A.17.4 $\mu$ IMU to UIC Cable Assembly

The NovAtel part number for the  $\mu$ IMU to UIC interface cable is 01019760 (Figure 90:  $\mu$ IMU to UIC Cable Assembly below). This cable provides power to the IMU and enables communication between the UIC and the IMU.



The dimensions in this drawing are in millimeters.

**Table 136:  $\mu$ IMU to UIC Cable Pinout**

P1 Pin ( $\mu$ IMU)	Signal	J2 Pin (UIC)
1	Ground	B2
2	Ground	A3
3	Transmit Data+	B20
4	Transmit Data-	B19
5	Transmit Clock-	B15
6	Transmit Clock+	B16
7	Ground	B3
8	Ground	B4
13	NOGO	B9
16	SYNC-	B17
17	IMU_5V25	A22
18	IMU_5V25	B22
19	IMU_5V25	B23

P1 Pin ( $\mu$ IMU)	Signal	J2 Pin (UIC)
20	Ground	A21 B21
21	Ground	B5 B11
22	Ground	A23 B24
26	Lug Ring	-
27	IMU_PDWARN	B6
30	IMU_RESET	B7
31	SYNC+	B18
	IMU_TYPE_3	A15 to A18
	IMU_TYPE_1	A13 to A11



## A.18 Universal IMU Enclosure (HG1700, LN200)

The Universal IMU Enclosure is available with the HG1700 and LN-200 IMUs.

**Table 137: Universal IMU Enclosure Physical Specifications**

PHYSICAL	
IMU Enclosure Size	168 mm x 195 mm x 146 mm
IMU Enclosure Weight	4.25 kg

See the following sections for more information about the IMUs available in the Universal IMU Enclosure.

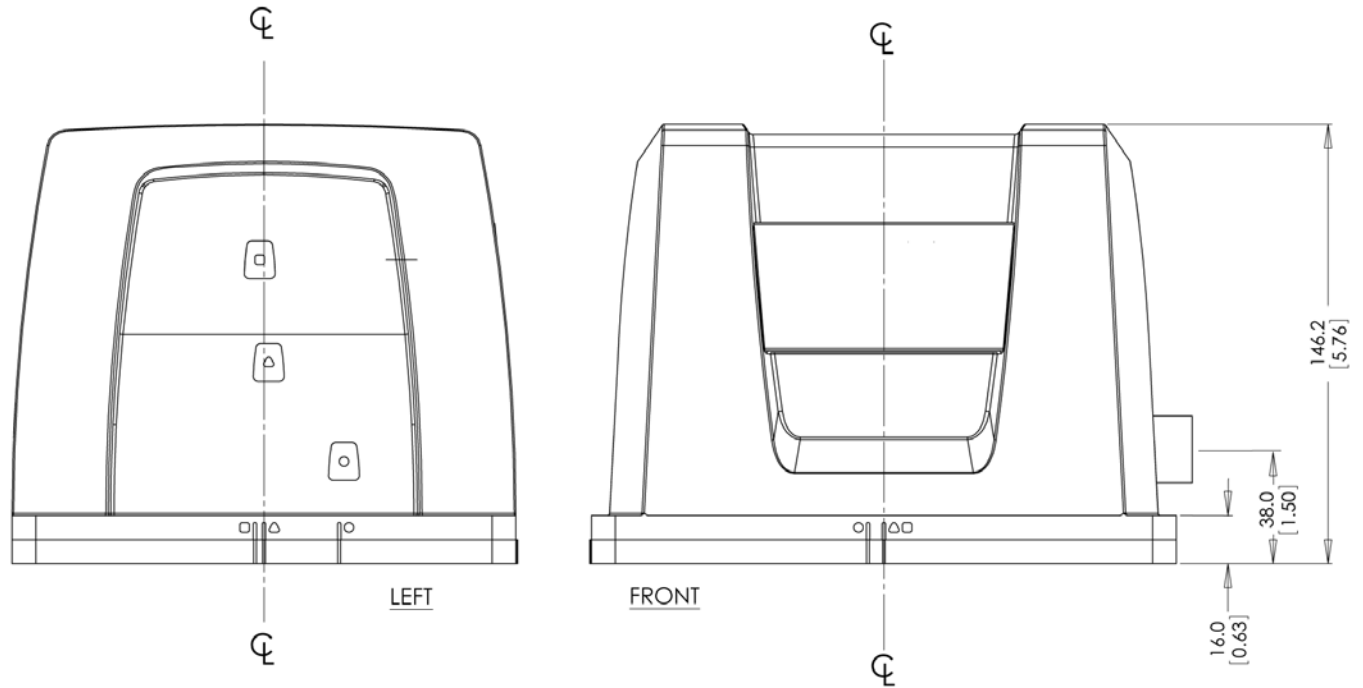
- *Universal IMU Enclosure Mechanical Drawings* on the next page
- *IMU Performance* on page 254
- *Electrical and Environmental* on page 256
- *Universal IMU Enclosure Interface Cable* on page 257

### A.18.1 Universal IMU Enclosure Mechanical Drawings



The dimensions for the drawing in this section are in mm [inches].

Figure 91: Universal IMU Enclosure Side Dimensions



**Figure 92: Universal IMU Enclosure Top/Bottom Dimensions**

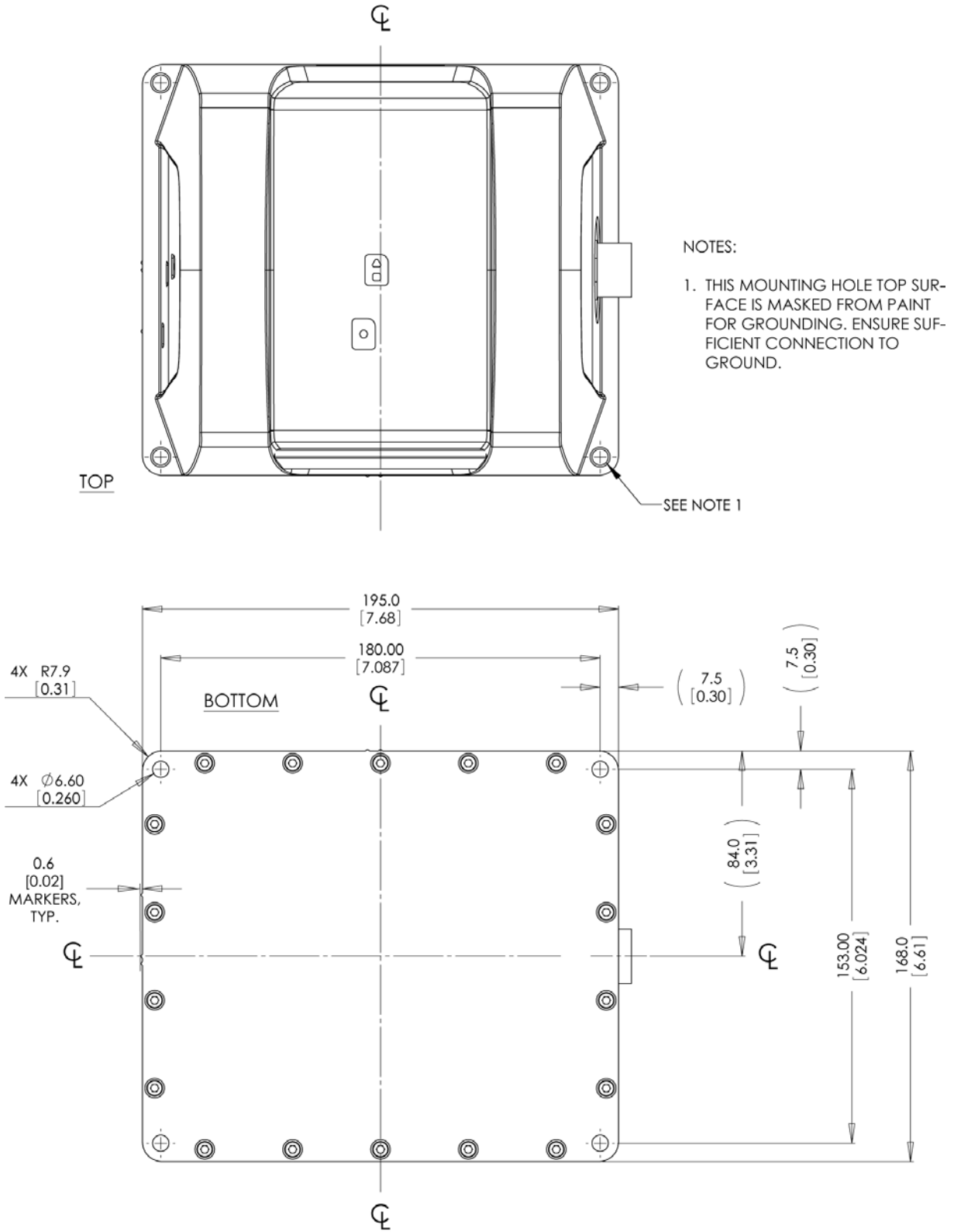


Figure 93: Universal IMU Center of Navigation

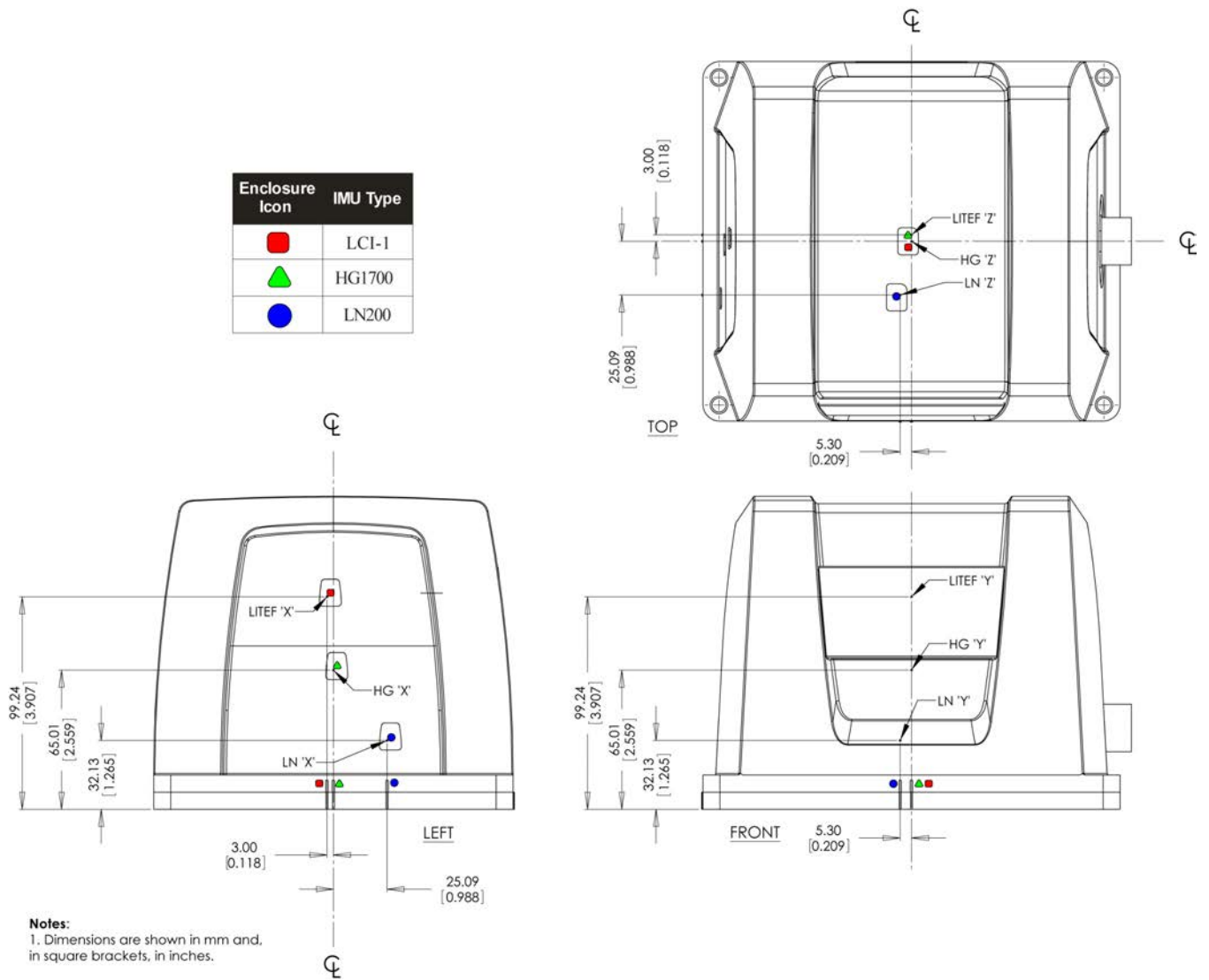
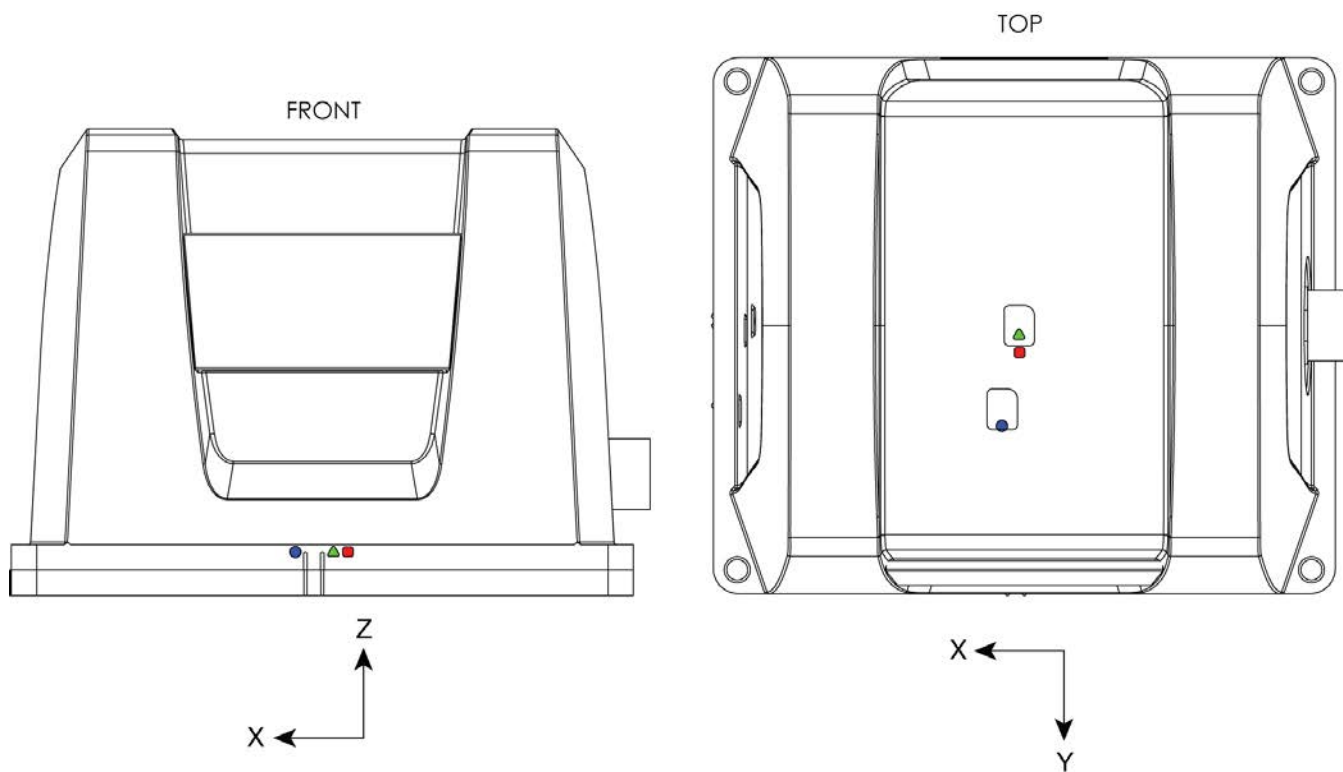


Figure 94: Universal IMU Frame Axis



**A.18.2 IMU Performance****Table 138: HG1700-AG58 IMU Performance**

<b>Gyroscope Performance</b>	
Gyro Input Range	$\pm 1000$ °/second
Gyro Rate Bias	1.0 °/hour
Gyro Rate Scale Factor	150 ppm
Angular Random Walk	0.125 °/ $\sqrt{\text{hour}}$
<b>Accelerometer Performance</b>	
Accelerometer Range	$\pm 50$ g
Accelerometer Linearity	500 ppm
Accelerometer Scale Factor	300 ppm
Accelerometer Bias	1.0 mg
<b>Data Rate</b>	
IMU Measurement	100 Hz

**Table 139: HG1700-AG62 IMU Performance**

<b>Gyroscope Performance</b>	
Gyro Input Range	$\pm 1000$ °/second
Gyro Rate Bias	5.0 °/hour
Gyro Rate Scale Factor	150 ppm
Angular Random Walk	0.5 °/ $\sqrt{\text{hour}}$
<b>Accelerometer Performance</b>	
Accelerometer Range	$\pm 50$ g
Accelerometer Linearity	500 ppm
Accelerometer Scale Factor	300 ppm
Accelerometer Bias	2.0 mg
<b>Data Rate</b>	
IMU Measurement	100 Hz

**Table 140: LN200 IMU Performance**

<b>Gyroscope Performance</b>	
Gyro Input Range	$\pm 1000$ °/second
Gyro Rate Bias	1.0 °/hour
Gyro Rate Scale Factor	100 ppm
Angular Random Walk	0.07 °/ $\sqrt{\text{hour}}$
<b>Accelerometer Performance</b>	
Accelerometer Range	$\pm 40$ g
Accelerometer Linearity	150 ppm
Accelerometer Scale Factor	300 ppm
Accelerometer Bias	0.3 mg
<b>Data Rate</b>	
IMU Measurement	200 Hz

**A.18.3 Electrical and Environmental**

**Table 141: Universal IMU Enclosure Electrical Specifications**

Electrical	
IMU Power Consumption	HG1700-AG58: 9 W (max) HG1700-AG62: 8 W (max) LN-200: 16 W (typical)
IMU Input Voltage	+12 to +28 VDC (all IMUs)
Receiver Power Consumption	1.8 W (typical, for all IMUs)
Input/Output Connectors	MIL-C-38999-III, 22 pin (all IMUs)
IMU Interface	RS-232 or RS-422

**Table 142: Universal IMU Enclosure Environmental Specifications**

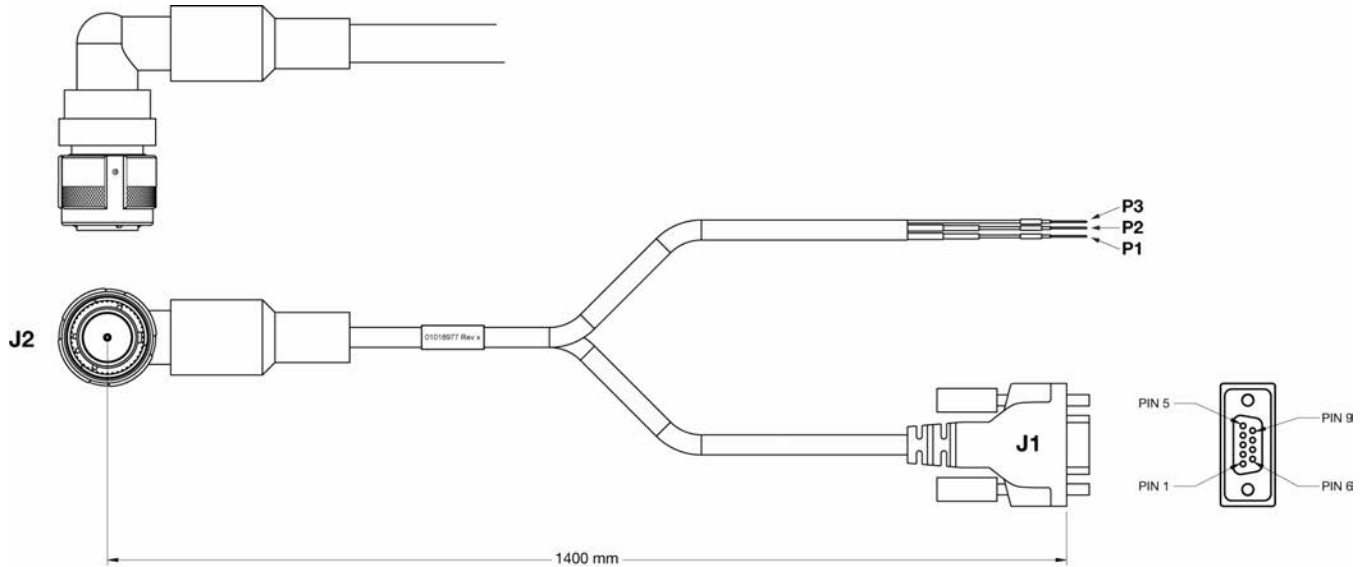
Environmental	
Temperature	HG1700-AG58, HG1700-AG62 Operating: -30°C to +60°C Storage: -45°C to +80°C
	LN-200 Operating: -30°C to +60°C Storage: -45°C to +80°C
Humidity	Operates at 95% RH, non-condensing (all IMUs)



### A.18.4 Universal IMU Enclosure Interface Cable

The NovAtel part number for the Universal IMU Enclosure interface cable is 01018977 (see *Figure 95: Universal IMU Enclosure Interface Cable* below). This cable provides power to the IMU from an external power source and enables communication between the receiver and the IMU.

**Figure 95: Universal IMU Enclosure Interface Cable**



**Table 143: Universal IMU Enclosure Interface Cable Pin-outs**

J2 Pinout	Function	Connector	Pin/Label
1	$V_{IN} (-)$	P2	Vin (-)
22	$V_{IN} (-)$		
2	Not used		
3	$V_{IN} (+)$	P1	Vin (+)
21	$V_{IN} (+)$		
4	Not used		
5	Not used		
6	Not used		
7	DAS (+)	J1	1
8	Not used		
9	DAS GND (-)	J1	5
10	Not used		

J2 Pinout	Function	Connector	Pin/Label
11	OEM_CTS/Rx-	J1	8
12	OEM_Rx/Rx+	J1	2
13	Not used		
14	DGND	J1	5
15	DGND	J1	5
16	Not used		
17	Not used		
18	Not used		
19	OEM_Tx/Tx+	J1	3
20	OEM_RTS/Tx-	J1	7
	Shield	P3	Shield

### Custom Cable Recommendations

The tables below provide recommendations for creating custom cables to replace the Universal IMU Enclosure interface cable (01018977).

**Table 144: Connectors**

Connector	Description
J1	DB-9, female
J2	MIL-DTL-38999 III, plug

**Table 145: Maximum Cable Length**

IMU	RS-232	RS-422
HG1700, LN-200, LCI-1	< 2.0 meters	< 50 meters
iIMU-FSAS	N/A	< 1.5 meters

## A.19 MIC - MEMS Interface Card

**Table 146: MEMS Interface Card Physical Specifications**

Physical	
MIC Size	74.9 mm x 45.7 mm x 19.5 mm (2.94" x 1.80" x 0.76")
MIC Weight	31 g (0.0683 lb)

See the following sections for more information about the MIC.

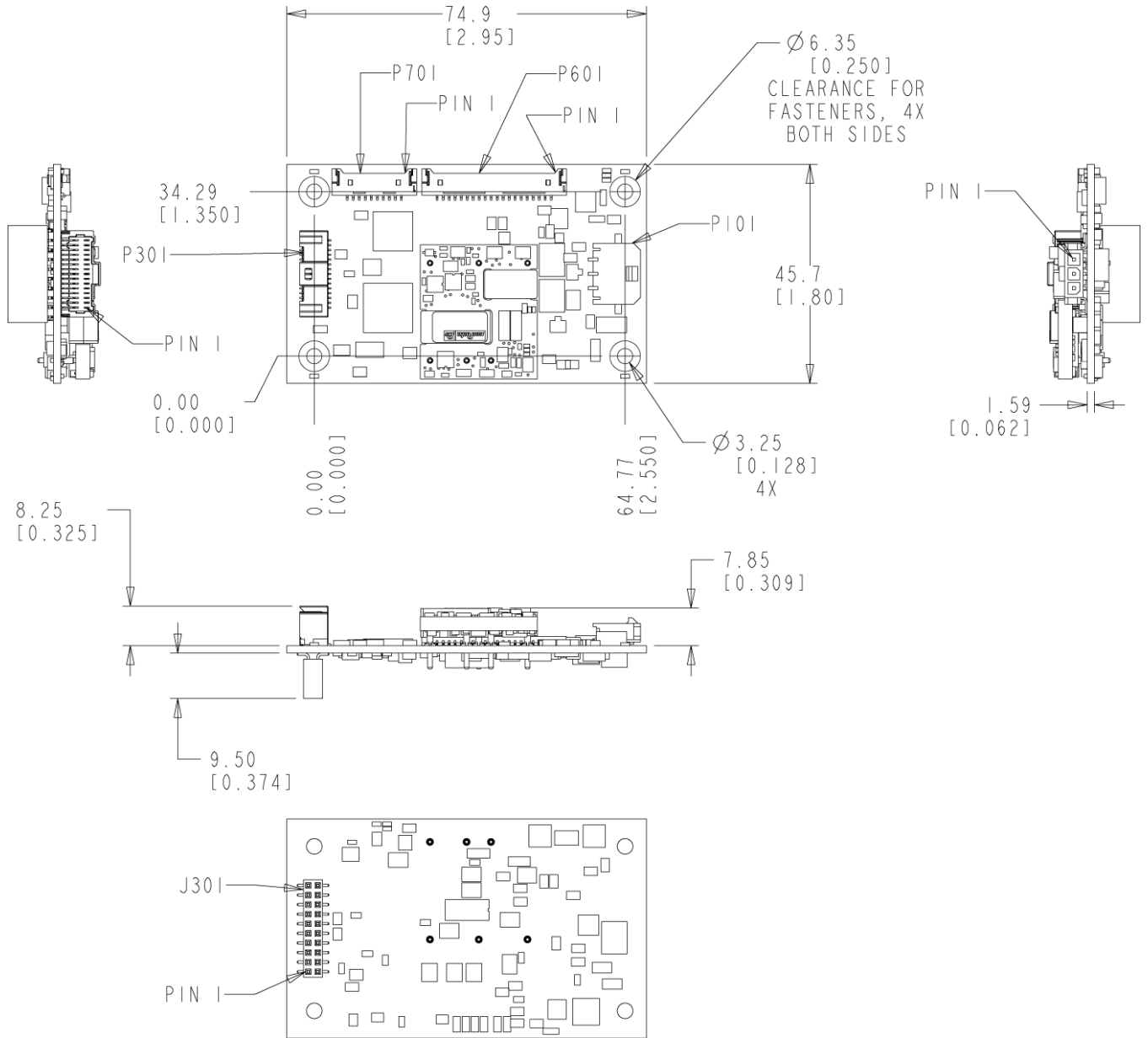
- *MIC Mechanical Drawings* on the next page
- *MIC Electrical and Environmental* on page 262
- *MIC Connectors* on page 263
- *HG1930 IMU-to-MIC Cable Assembly* on page 268
- *HG1700 and HG1900 IMU-to-MIC Cable Assembly* on page 270

**A.19.1 MIC Mechanical Drawings**

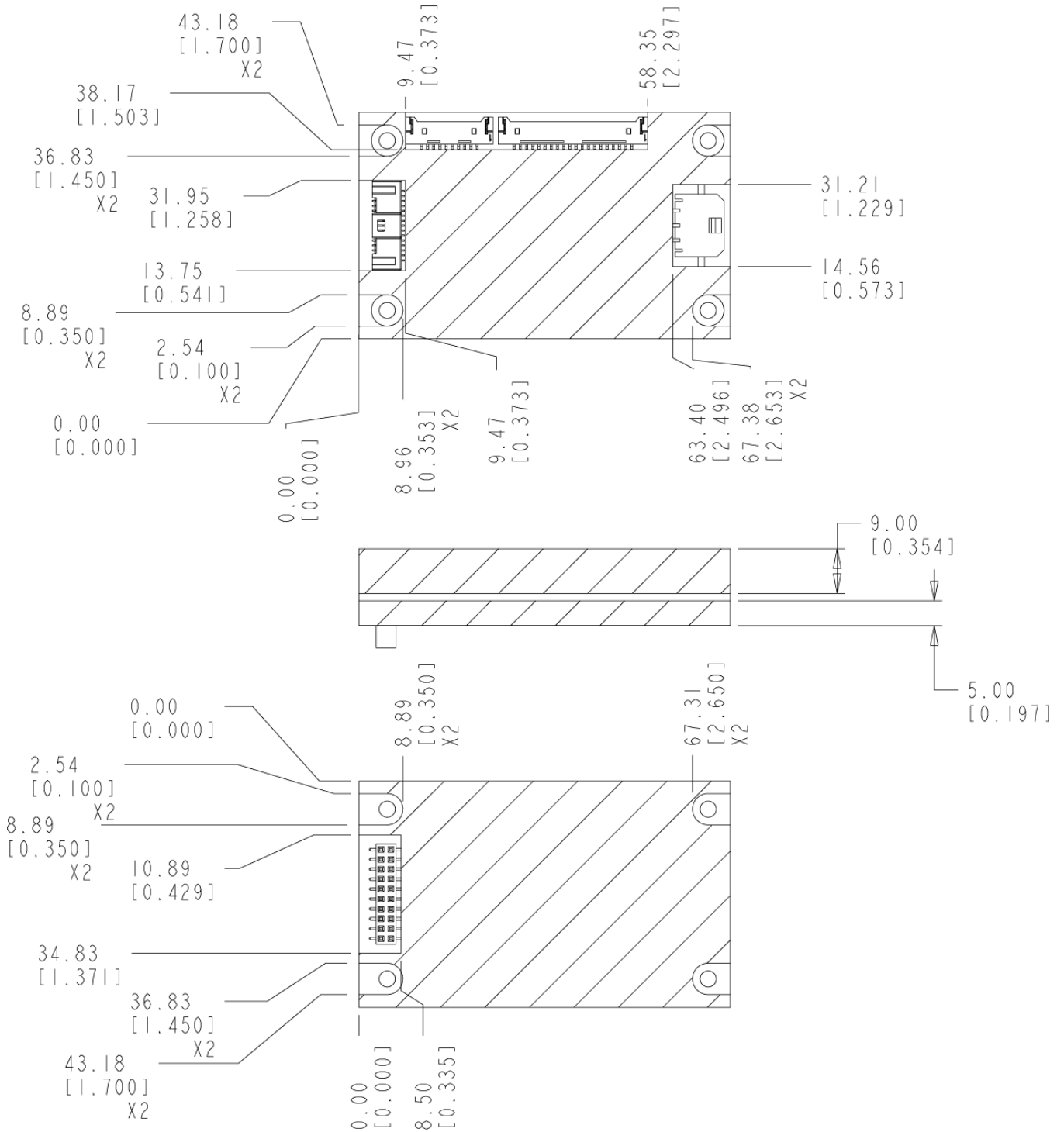


The dimensions in the following drawings are in millimeters and [inches].

**Figure 96: MIC Top/Bottom Dimensions**



**Figure 97: MIC Keep-Out Zone**



Cross hatched areas indicate “keepout” areas intended for NovAtel circuitry. NovAtel reserves the right to modify components and component placements inside cross hatched keepout zones, while maintaining design, form, fit and function.

**A.19.2 MIC Electrical and Environmental**

**Table 147: MIC Electrical Specifications**

<b>Electrical</b>	
MIC Input Voltage	10 VDC to 30 VDC
Power Consumption <sup>1</sup>	+5 VDC @ 1 Amp for IMU +3.3 VDC @ 1 Amp for IMU +15 VDC @ 0.5 Amp for IMU -15 VDC @ 0.08 Amp for IMU +3.3 VDC @ 0.6 Amp for OEM719
IMU Data Interfaces	UART and SDLC over RS-422

**Table 148: MIC Electrical and Environmental Specifications**

<b>Environmental</b>	
Operating Temperature	-40°C to +75°C (-40°F to 167°F)
Storage Temperature	-55°C to +90°C (-67°F to 194°F)
Random Vibe	MIL-STD-810G (Cat 24, 7.7 g RMS)
Sine Vibe	IEC 60068-2-6
Bump	IEC 68-2-29 (25 g)
Shock	MIL-STD-810G (40 g)

<sup>1</sup>Sample system power consumption: 5.7 W when powering an HG1900 IMU and OEM719 receiver, in board stack configuration, from VIN=15 VDC at +25°C.

**A.19.3 MIC Connectors**

**Table 149: MIC Connectors**

Connector	Description	Part Number	Mating Connector Part number
J301	20-pin OEM719 mating connector	ASP-163577-01 SAMTEC	Connects only to OEM719 receiver.
P101	3-pin locking power connector	43650-0313 Molex Electronics	43645-0300 Molex Electronics
P301	30-pin locking communication connector	501571-3007 Molex Electronics	501189-3010 Molex Electronics
P601	20-pin locking IMU connector for Honeywell and Sensoror IMUs	53780-2070 Molex Electronics	51146-2000 Molex Electronics
P701	10-pin locking IMU connector for ADIS IMUs	53780-1070 Molex Electronics	51146-1000 Molex Electronics

**Table 150: Pinouts for Power Connector (P101)**

Pin	Signal	Type	Description	Comments
1	VIN+	Power	Power input	+10 VDC to +30 VDC
2	VIN-	Power	Power return	Connect to negative terminal of battery
3	GND	Power	Chassis ground	

**Table 151: Pinouts for User Interface Connector (P301)**

Pin	Signal	Type	Description	Comments
1	N/C			
2	N/C			
3	LED3	Output	Status LED 3 / Self-test	
4	LED2	Output	Status LED 2 / GPS Time Status	
5	DGND	Power	Digital ground	

Pin	Signal	Type	Description	Comments
6	LED1	Output	Status LED 1 / IMU Data Status	
7	Reserved	N/A	Leave as no connect	
8	DGND	Power	Digital ground	
9	Reserved	N/A	Leave as no connect	
10	Reserved	N/A	Leave as no connect	
11	N/C	N/A		
12	N/C	N/A		
13	USB D-	Bidirectional	USB interface data (-)	Only available in board stackup with OEM719 In standalone, no connect
14	USB D+/ COM3 RX	Bidirectional	USB interface data (+)/ COM3 receive data	Only available in board stackup with OEM719 In standalone, no connect The USB port is enabled by default and the COM3 port is disabled by default. If you enable the COM3 port, the USB port is disabled.
15	RESETIN	Input	OEM719 reset in	Only available in board stackup with OEM719 In standalone, no connect
16	VARF/ CAN1 RX	Output/ Input	Variable frequency output/ CAN1 receive data	Only available in board stackup with OEM719 In standalone, no connect The VARF output is enabled by default and the CAN1RX input is disabled by default. If you disable VARF, the CAN1RX input is enabled.
17	EVENT2/ CAN1 TX	Input/ Output	Event2 input/ CAN1 transmit data	Only available in board stackup with OEM719 In standalone, no connect The Event2 input is enabled by default and the CAN1TX output is disabled by default. If you disable EVENT2, the CAN1TX output is enabled.
18	CAN2 RX	Input	CAN2 receive data	Only available in board stackup with OEM719 In standalone, no connect



Pin	Signal	Type	Description	Comments
19	EVENT1/ COM3 TX	Input	Event1 input/ COM3 transmit data	Only available in board stackup with OEM719 In standalone, no connect The Event1 input is enabled by default and the COM3 port is disabled by default. If you enable the COM3 port, the Event1 input is disabled.
20	DGND	Power	Digital ground	
21	MIC TX	Output		In board stackup with OEM719, this pin is for firmware download In standalone use, this pin can be used for either firmware download and/or for IMU data communication to a SPAN receiver
22	MIC RX	Input		In board stackup with OEM719, this pin is for firmware download In standalone use, this pin can be used for either firmware download and/or for IMU data communication to a SPAN receiver
23	DGND	Power		
24	USER_ TXD2	Output		In board stackup with OEM719, this is the access to the OEM719 COM2 port In standalone, no connect
25	USER_ RXD2	Input		In board stackup with OEM719, this is the access to the OEM719 COM2 port In standalone, no connect
26	DGND	Power	Digital ground	
27	PV	Output	Access to OEM719 position valid	Only available in board stackup with OEM719 In standalone, no connect
28	DGND	Power	Digital ground	
29	1PPS	Output	Access to OEM719 1PPS	Only available in board stackup with OEM719 In standalone, no connect
30	CAN2 TX	Output	CAN2 transmit data	Only available in board stackup with OEM719 In standalone, no connect



All signal I/O with the exception of USB port are at LVCMOS levels.

Table 152: Pinouts for IMU Connector (P601)

Pin	Signal	Type	Description	Comments
1	GND		Chassis ground	
2	GND		Chassis ground	
3	15V	Output Power	Positive 15 VDC supply	Enabled/disabled depending on the IMU type detected
4	15V	Output Power	Positive 15 VDC supply	Enabled/disabled depending on the IMU type detected
5	-15V	Output Power	Negative 15 VDC supply	Enabled/disabled depending on the IMU type detected
6	DGND		Digital ground	Enabled/disabled depending on the IMU type detected
7	DGND		Digital ground	Enabled/disabled depending on the IMU type detected
8	IMU VDD	Output Power	Positive voltage supply for IMU logic circuits	IMU_VDD can be +3.3 VDC or +5 VDC depending on the IMU type detected
9	IMU VDD	Output Power	Positive voltage supply for IMU logic circuits	
10	DGND	Power	Digital ground	
11	Tx Data+	Output	Serial data out+	Non-inverting
12	Tx Data-	Output	Serial data out-	Inverting
13	RX Data+	Input	Serial data in+	Non-inverting RS-422 data input
14	RX Data-	Input	Serial data in-	Inverting RS-422 data input
15	CLK+	Bidirectional	Serial data clock+	Non-inverting portion of RS-422 link
16	CLK-	Bidirectional	Serial data clock-	Inverting portion of RS-422 link
17	IMU DAS	Bidirectional	Data acquisition signal	Provides synchronization for IMU data (LVCMOS level)
18	IMUTYPE0	Input	detect IMU type	LVCMOS level, not 5V tolerant
19	IMUTYPE1	Input	detect IMU type	LVCMOS level, not 5V tolerant
20	IMUTYPE2	Input	detect IMU type	LVCMOS level, not 5V tolerant



All signal I/O are at LVCMOS levels.

**Table 153: Pinouts for IMU Connector (P701)**

Pin	Signal	Type	Description	Comments
1	IMU_VDD	Output Power	Positive voltage supply for IMU logic circuits	IMU_VDD must be +3.3 VDC
2	IMU_VDD	Output Power	Positive voltage supply for IMU logic circuits	
3	SPI_NSS		Slave Select	LVC MOS level, not 5V tolerant
4	SPI_SCK	Output	Serial Clock	LVC MOS level, not 5V tolerant
5	DGND		Digital Ground	
6	SPI_MOSI	Output	Master Output / Slave Input	LVC MOS level, not 5V tolerant
7	SPI_MISO	Input	Master Input / Slave Output	LVC MOS level, not 5V tolerant
8	DGND		Digital Ground	
9	IMU_DIO1	Bidirectional		LVC MOS level, not 5V tolerant
10	IMU_DIO2	Bidirectional		LVC MOS level, not 5V tolerant

**Table 154: MIC LED Indicator Drivers**

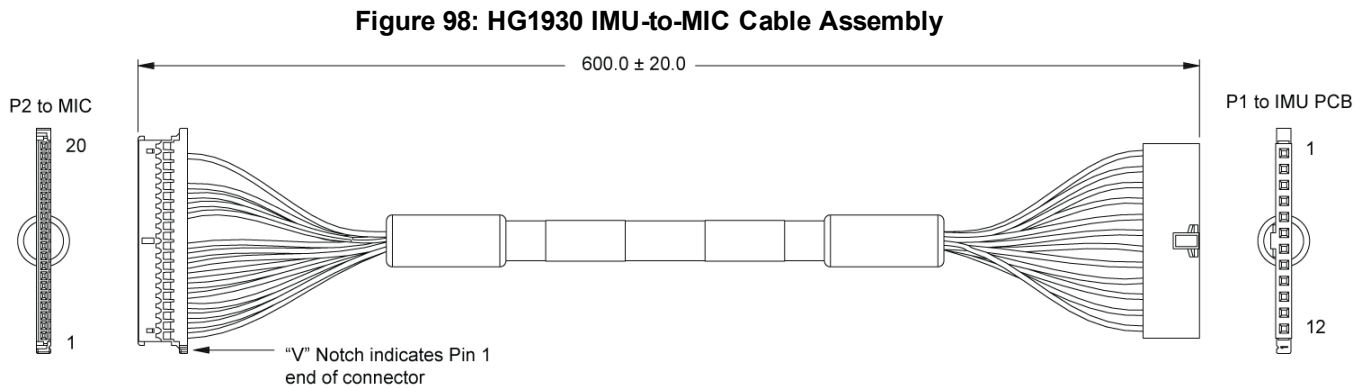
Board State	Status LED 1	Status LED 2	Status LED 3
Bootup	Toggles at 2 Hz Self-test	Off	On
Normal Operation	On	Toggles at 2 Hz GPS Time	Toggles at 2 Hz IMU Data
No IMU Connected	Toggles at 1 Hz Error	Toggles at 2 Hz GPS Time	Toggles at 1 Hz Error



When the MIC boots up, it requires approximately 10 seconds to perform a self-test. If a software update has been performed, the board can take up to 70 seconds at startup to complete the reprogramming.

### A.19.4 HG1930 IMU-to-MIC Cable Assembly

The NovAtel part number for the HG1930 IMU-to-MIC interface cable is 01018827 (*Figure 98: HG1930 IMU-to-MIC Cable Assembly* below). This cable provides power to the IMU and enables communication between the MIC and the IMU.



The dimensions in this drawing are in millimeters.

**Table 155: HG1930 IMU-to-MIC Cable Assembly**

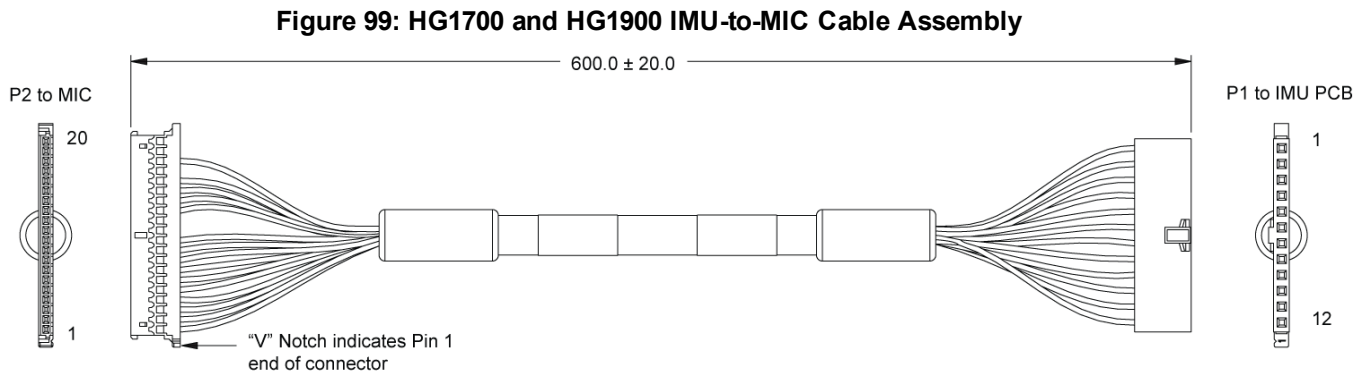
P1 IMU Cable End (FCI-MINITEK)	P2 MIC Cable End
Pin	Pin
1	15
2	16
3	13
4	14
5	8
7	7
6	9
8	10
11	3
	4
12	6
	19
9	5
10	1
	2



For more information, refer to the IMU documentation provided by Honeywell.

### A.19.5 HG1700 and HG1900 IMU-to-MIC Cable Assembly

The NovAtel part number for the HG1700 and HG1900 IMU-to-MIC interface cable is 01018828 (*Figure 99: HG1700 and HG1900 IMU-to-MIC Cable Assembly* below). This cable provides power to the IMU and enables communication between the MIC and the IMU.



The dimensions in this drawing are in millimeters.

**Table 156: HG1700 and HG1900 IMU-to-MIC Cable Assembly**

P1 IMU Cable End (FCI-MINITEK)	P2 MIC Cable End
Pin	Pin
1	15
2	16
3	13
4	14
5	8
7	7
6	9
8	10
11	3
	4
12	6
	18
9	5
10	1
	2



For more information, refer to the IMU documentation provided by Honeywell.

## A.20 UIC - Universal IMU Controller

**Table 157: UIC Physical Specifications**

Physical	
UIC Size	100 mm x 113 mm x 17.54 mm (3.94" x 4.45" x 0.69")
UIC Weight	125 g (0.28 lb)

See the following sections for more information about the UIC.

- *UIC Mechanical Drawings* on the next page
- *UIC Electrical and Environmental* on page 275
- *UIC Connectors* on page 276
- *HG1900 IMU to UIC Cable Assembly* on page 280
- *LN200 IMU to UIC Cable Assembly* on page 281

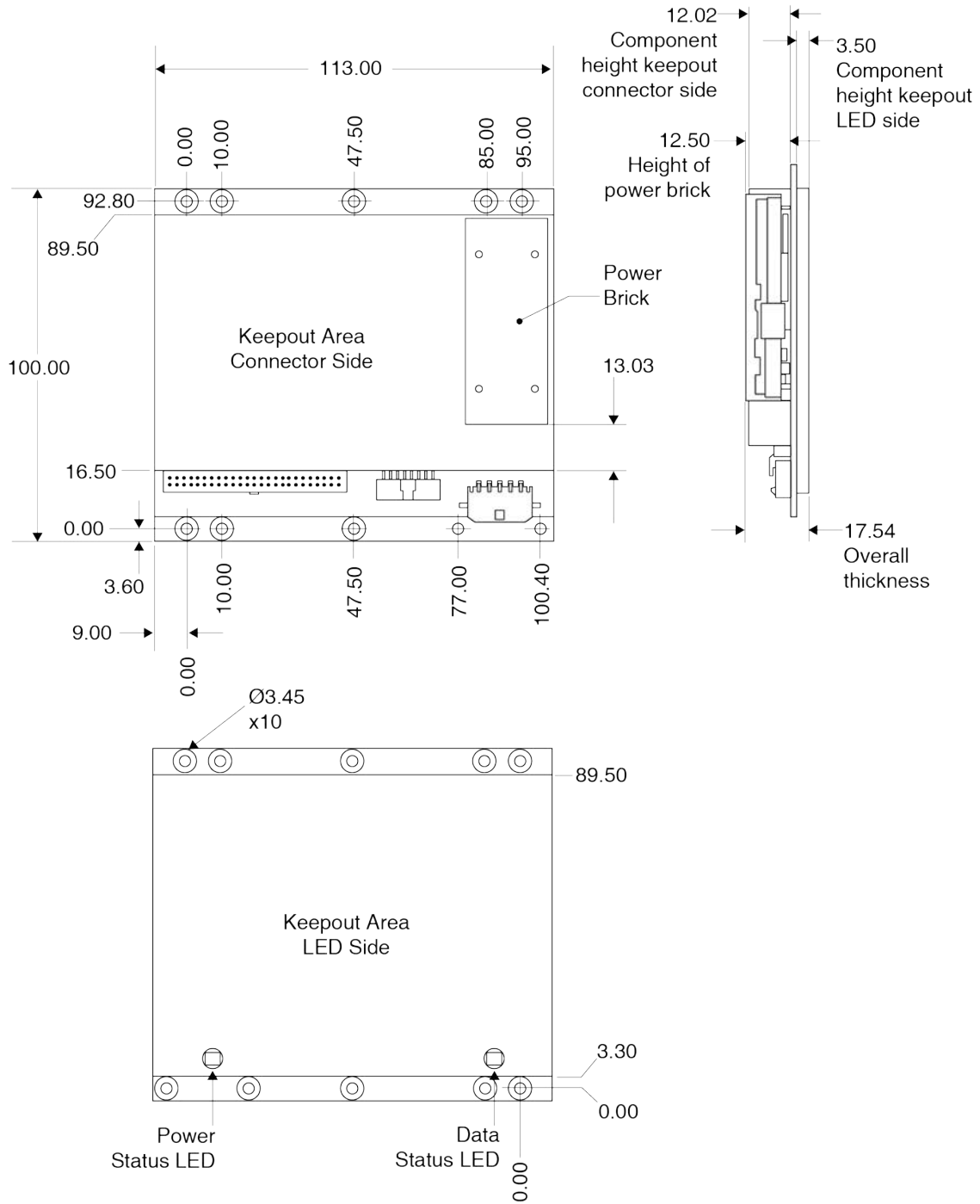


**A.20.1 UIC Mechanical Drawings**

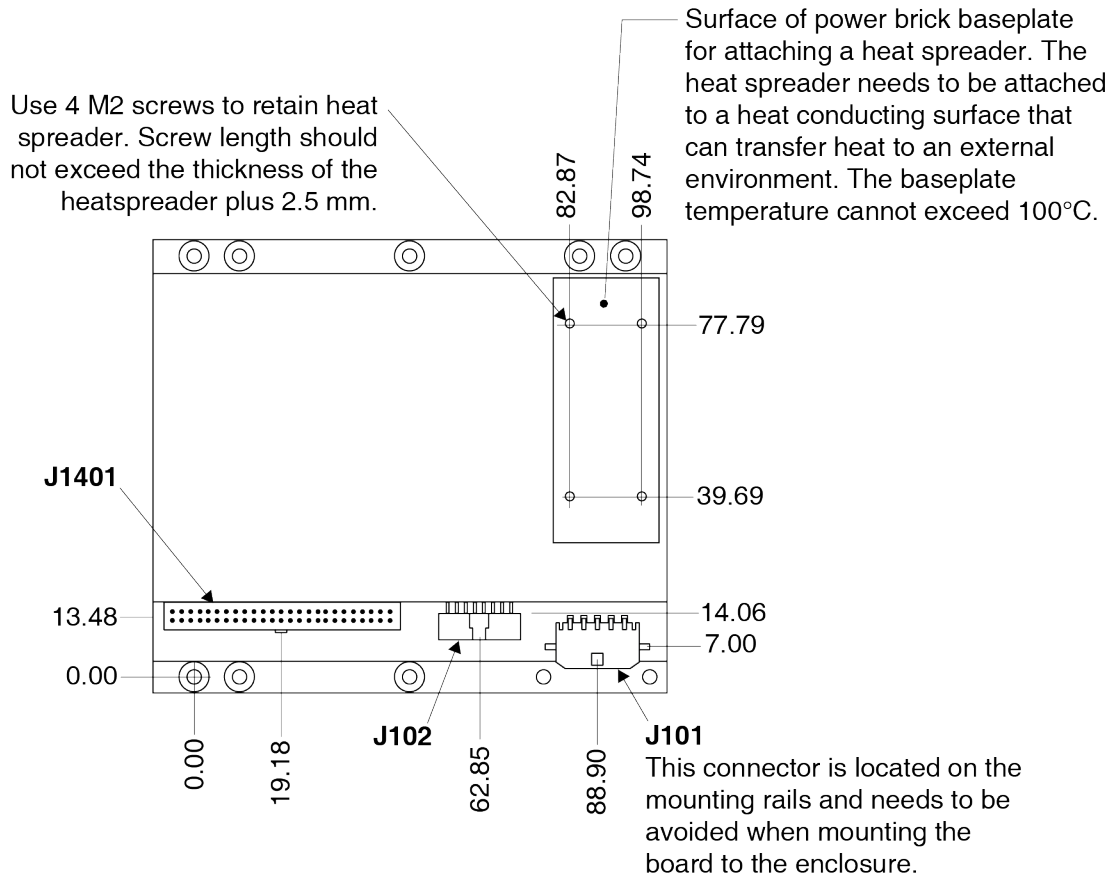


The dimensions in the following drawings are in millimeters.

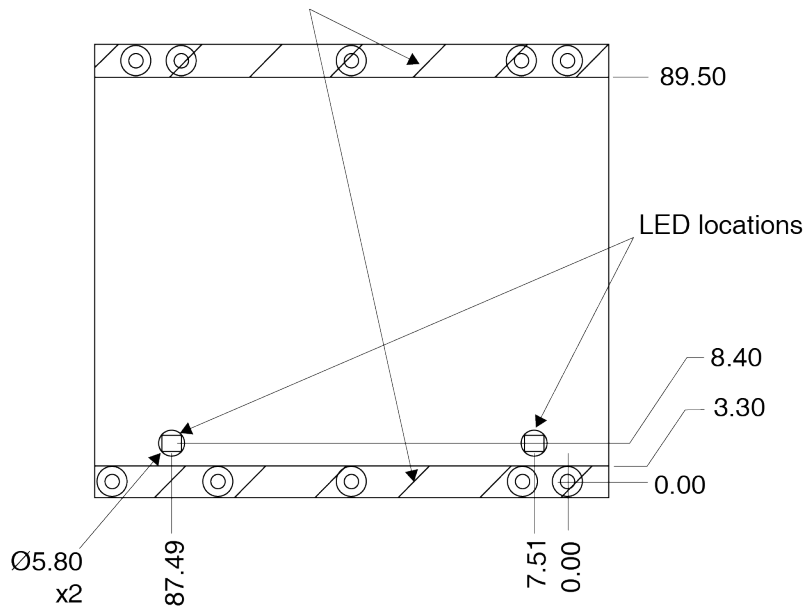
**Figure 100: UIC Dimensions and Keep Out Zones**



**Figure 101: UIC Connectors, LEDs and Heat Sink Details**



Cross hatching indicates mounting rail on both sides with noted exception for J101 connector.



**A.20.2 UIC Electrical and Environmental****Table 158: UIC Electrical Specifications**

<b>Electrical</b>	
UIC Input Voltage	10 VDC-34 VDC
Power Consumption	4 W <sup>1</sup>
IMU Data Interfaces	UART and SDLC over RS-422

**Table 159: UIC Environmental Specifications**

<b>Environmental</b>	
Operating Temperature	-40°C to +75°C (-40°F to 167°F)
Storage Temperature	-55°C to +90°C (-67°F to 194°F)
Random Vibe	MIL-STD-810G (Cat 24, 7.7 g RMS)
Sine Vibe	IEC 60068-2-6
Bump	IEC 68-2-29 (25 g)
Shock	MIL-STD-810G (40 g)

<sup>1</sup>At 12 VDC input.

**A.20.3 UIC Connectors**

**Table 160: UIC Connectors**

Connector	Description	Part Number	Mating Connector Part number
J101	5-pin UIC power connector <sup>1</sup>	43650-0513 Molex Electronics	43645-0500 Molex Electronics
J102	16-pin UIC to receiver communication connector <sup>2</sup>	98464-G61-16LF FCI Electronics	90311-016LF FCI Electronics
J1401	50-pin UIC to IMU communication connector	LTMM-125-02-L-D (Samtec)	SQT-125-01-L-D (Samtec)

**Table 161: Pinouts for Power Connector (J101)**

Pin	Signal	Type	Description	Comments
1	VIN+	Power	Power input	+10 VDC to +34 VDC
2	VIN+	Power	Power input	+10 VDC to +34 VDC
3	VIN-	Power	Power return	Connect to negative terminal of battery
4	VIN-	Power	Power return	Connect to negative terminal of battery
5	GND	Power	Chassis ground	

**Table 162: Pinouts for UIC to Receiver Communications Connector (J102)**

Pin	Signal <sup>3</sup>	Type	Description	Comments
A1	UIC_RX+	Input	RS-422 serial data in+	RS-422 serial port for UIC to receiver communication
A2	UIC_RX-	Input	RS-422 serial data in-	
A3	UIC_TX+	Output	RS-422 serial data out+	
A4	UIC_TX-	Output	RS-422 serial data out-	
A5	A+	Input	Wheel sensor input A (+)	Connects to the wheel sensor.
A6	A-	Input	Wheel sensor input A (-)	Connects to the wheel sensor.
A7	Reserved			

<sup>1</sup>A filter module (similar to Delta FL 75L07) in series with the power cable maybe needed to pass conducted emission.

<sup>2</sup>A tubular ferrite bead (similar to Laird Technologies 28B0375-300) maybe attached to the data cable to reduce radiated emissions.

<sup>3</sup>All signal I/O are at LVCMOS levels (not 5V tolerant).

Pin	Signal <sup>1</sup>	Type	Description	Comments
A8	Reserved			
B1	Reserved			
B2	Reserved			
B3	EVENT_OUT+	Output	Event output (+)	
B4	EVENT_OUT-	Output	Event output (-)	
B5	B+	Input	Wheel sensor input B (+)	Connects to the wheel sensor.
B6	B-	Input	Wheel sensor input B (-)	Connects to the wheel sensor.
B7	Reserved (do not connect)			
B8	CGND	Power	Chassis ground	

**Table 163: Pinouts for UIC to IMU Communications Connector (J1401)**

Pin	Signal <sup>2</sup>	Type	Description
1	3.3V	Output Power	Positive 3.3 VDC supply
2	3.3V	Output Power	Positive 3.3 VDC supply
3	3.3V	Output Power	Positive 3.3 VDC supply
4	GND	Power	Digital ground
5	GND	Power	Digital ground
6	GND	Power	Digital ground
7	15V	Output Power	Positive 15 VDC supply
8	GND	Power	Digital ground
9	-15V	Output Power	Negative 15 VDC supply
10	GND	Power	Digital ground
11	NSS		SPI Slave Select
12	PWRDOWNx	Output	Power down warning
13	SCK	Output	SPI Serial Clock
14	RESETIMUx	Output	Reset IMU
15	GND	Power	Digital ground

<sup>1</sup>All signal I/O are at LVCMOS levels (not 5V tolerant).

<sup>2</sup>All signal I/O are at LVCMOS levels (not 5V tolerant).

Pin	Signal <sup>1</sup>	Type	Description
16	GND	Power	Digital ground
17	MISO	Input	SPI Master Input / Slave Output
18	NOGOx		
19	MOSI	Output	SPI Master Output / Slave Input
20	DIO2		
21	GND	Power	Digital ground
22	GND	Power	Digital ground
23	IMU_TYPE0	Input	Detect IMU type 0
24	IMU_EVENT_IN		
25	IMU_TYPE1	Input	Detect IMU type 1
26	IMU_EVENT_OUT		
27	IMU_TYPE2	Input	Detect IMU type 2
28	GND	Power	Digital ground
29	IMU_TYPE3	Input	Detect IMU type 3
30	TXC-		
31	IMU_DATA_OUT1-		
32	TXC+		
33	IMU_DATA_OUT1+		
34	SYNC-		
35	GND	Power	Digital ground
36	SYNC+		
37	IMU_DATA_OUT2-		
38	TXD-		
39	IMU_DATA_OUT2+		
40	TXD+		
41	GND	Power	Digital ground
42	GND	Power	Digital ground
43	5.25V	Output Power	Positive 5.25 VDC supply

<sup>1</sup>All signal I/O are at LVCMOS levels (not 5V tolerant).

---

Pin	Signal <sup>1</sup>	Type	Description
44	5.25V	Output Power	Positive 5.25 VDC supply
45	GND	Power	Digital ground
46	5.25V	Output Power	Positive 5.25 VDC supply
47	GND	Power	Digital ground
48	GND	Power	Digital ground
49	-5.25V	Output Power	Negative 5.25 VDC supply
50	-5.25V	Output Power	Negative 5.25 VDC supply

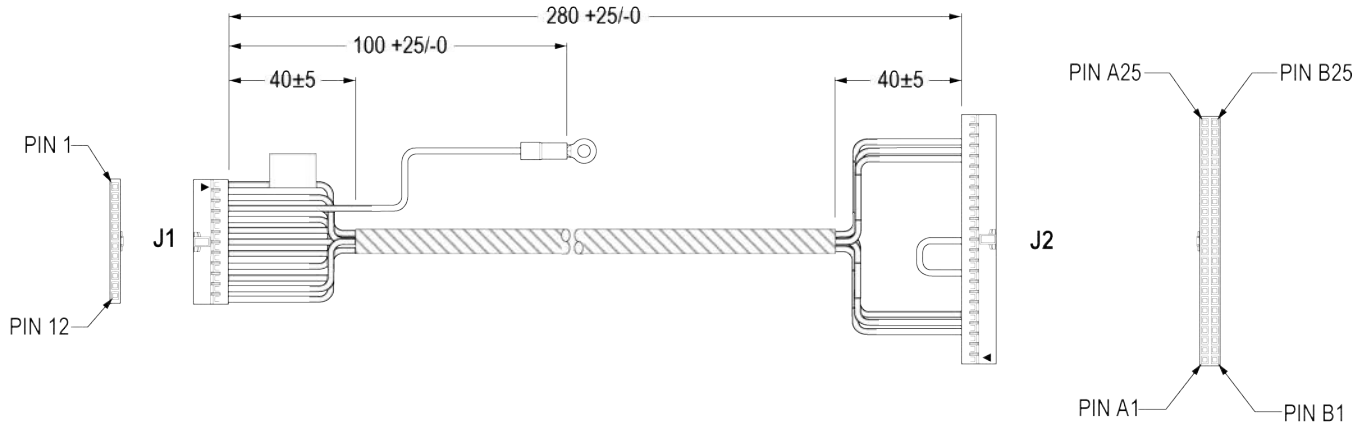
---

<sup>1</sup>All signal I/O are at LVCMOS levels (not 5V tolerant).

### A.20.4 HG1900 IMU to UIC Cable Assembly

The NovAtel part number for the HG1900 IMU to UIC interface cable is 01019762 (Figure 102: OEM-IMU-HG1900 IMU to UIC Cable Assembly below). This cable provides power to the IMU and enables communication between the MIC and the IMU.

**Figure 102: OEM-IMU-HG1900 IMU to UIC Cable Assembly**



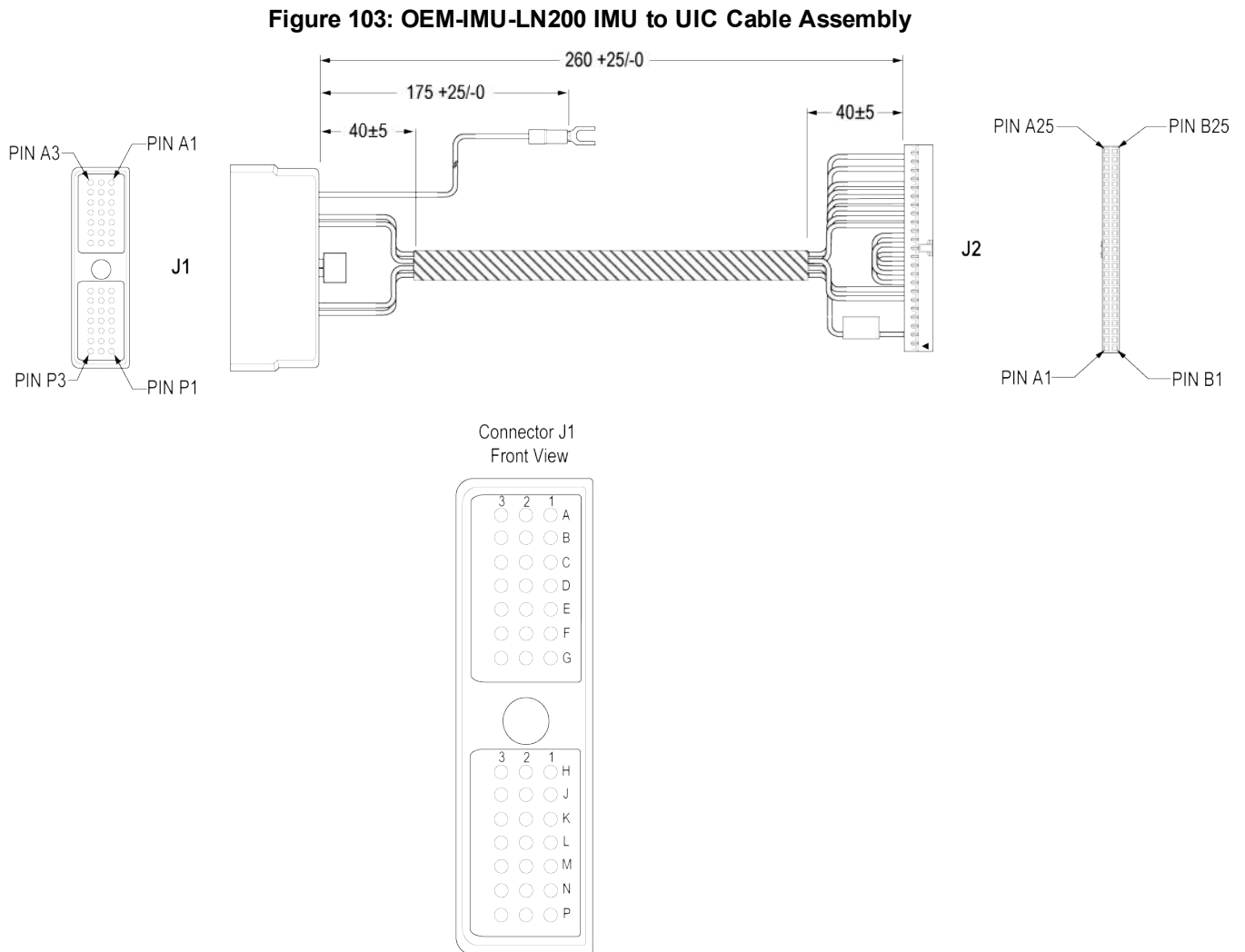
**Table 164: OEM-IMU-HG1900 IMU to UIC Cable Pinout**

J1 Pins (to HG1900)		J2 Pins (to UIC)
1		A3 B5
2		A4
3		Lug Ring
4		A5
5		A23
6		B21
7		B22
8		A22
9		B19
10		B20
11		A16
12		A17
		A11 to A12



### A.20.5 LN200 IMU to UIC Cable Assembly

The NovAtel part number for the LN200 IMU to UIC interface cable is 01019763 (*Figure 103: OEM-IMU-LN200 IMU to UIC Cable Assembly* below). This cable provides power to the IMU and enables communication between the MIC and the IMU.



**Table 165: OEM-IMU-LN200 IMU to UIC Cable Pinout**

J1 Pins (to LN200)	J2 Pins (to UIC)
A2	B19
A3	B15
B1	B20
B2	B16

J1 Pins (to LN200)		J2 Pins (to UIC)
C1		A3 B14
D1		A24 B24
D2		A21 B21
D3		Lug Fork
E1		A22
E2		B22
E3		B23
F3		A4
G2		A5
K1		B4 B5
L2		B18
L3		B17
		A8 to A13
		A11 to 12
		A15 to A18

# APPENDIX B HG1700 IMU in Universal Enclosure

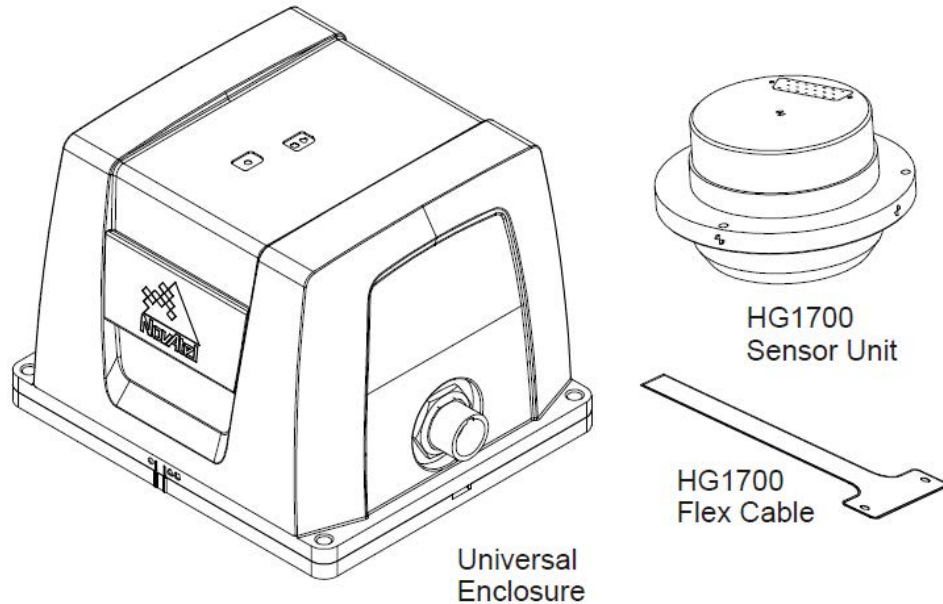


**Important!** Assemble in accordance with applicable industry standards. Ensure all ESD measures are in place, in particular, use a ground strap before exposing or handling any electronic items, including the IMU. Take care to prevent damaging or marring painted surfaces, O-rings, sealing surfaces and the IMU.

The following procedure provides the necessary information to install the HG1700 sensor into the Universal Enclosure (NovAtel part number 01018589), both illustrated below. The steps required for this procedure are:

- Disassemble the Universal Enclosure
- Install the HG1700 Sensor Unit
- Reassemble the Universal Enclosure

**Figure 104: Required Parts**



Use thread-locking fluid on all fasteners except for the flex cable connectors.



Torque values for all fasteners, including those for the flex cable, are as follows:

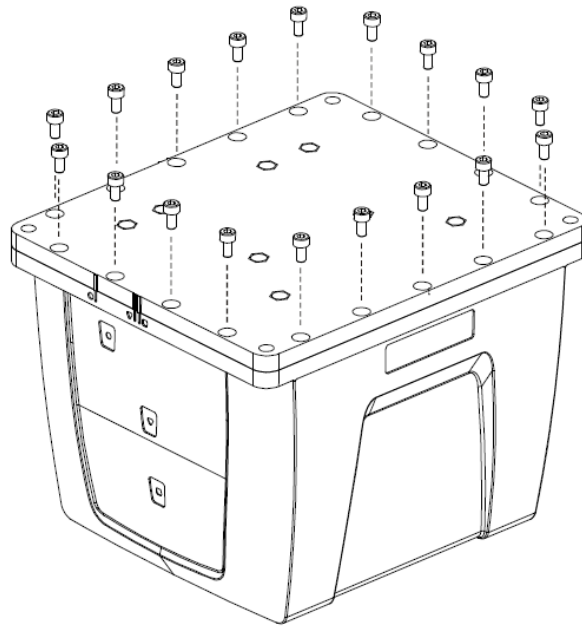
- Size 2-56: 0.20-0.25 N-m (1.8-2.2 lb-in) [28-35 oz/in]
- Size M4: 1.36-1.58 N-m (12.0-14.0 lb-in)
- Size 8-32: 1.55-1.70 N-m (13.7-15.0 lb-in)

## B.1 Disassemble the Universal Enclosure

Disassemble the Universal Enclosure as follows:

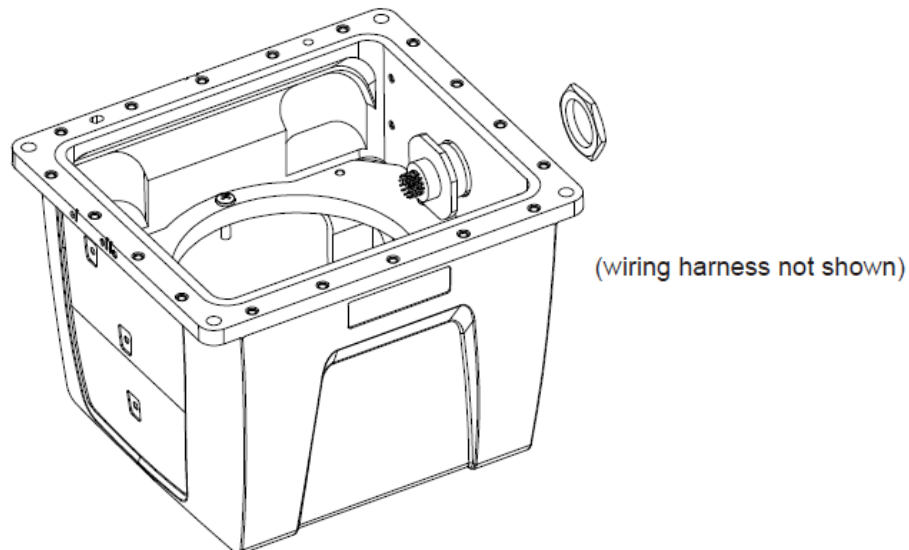
1. Using a 3 mm hex bit, remove the M4 screws (they will be reused) and the base, as shown in *Figure 105: Remove Base* below. Ensure the O-rings come with the base when it is removed, and that they are not damaged.

**Figure 105: Remove Base**



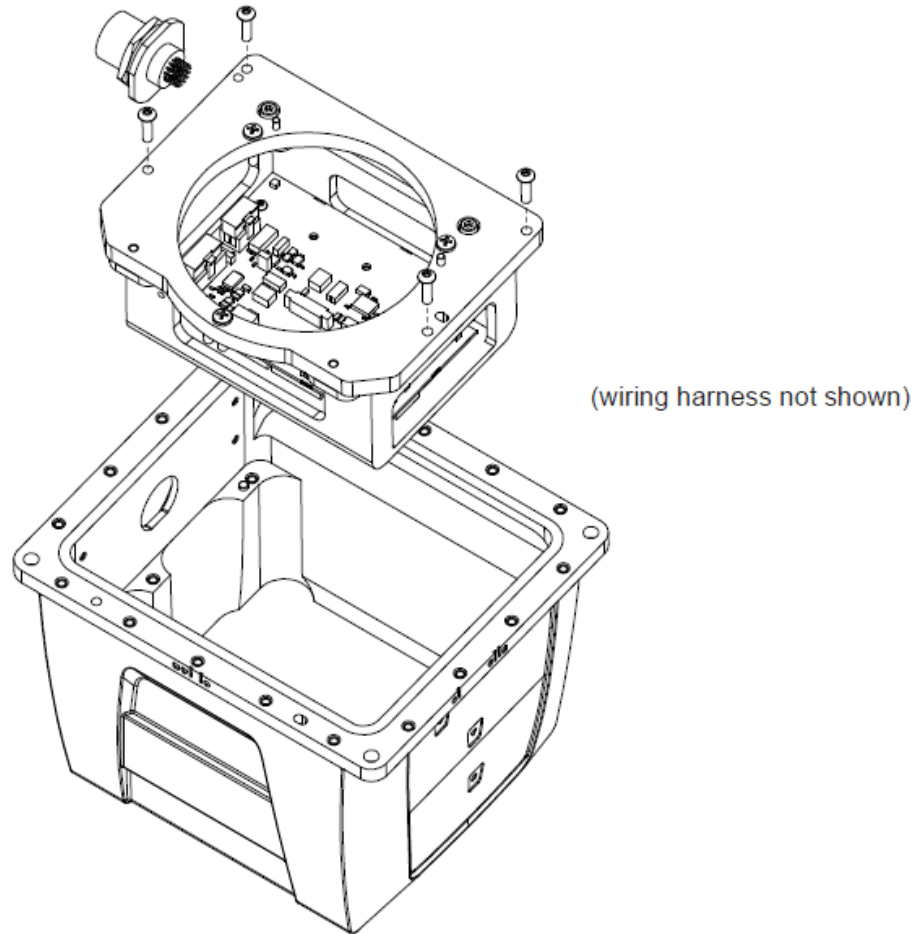
2. Using a 30 mm socket, remove the jam nut and free the wiring harness connector from the body, as shown in *Figure 106: Disconnect Wiring Harness from Enclosure Body* below. Retain the O-ring and the jam nut for reassembly.

**Figure 106: Disconnect Wiring Harness from Enclosure Body**



3. Using a 2.5 mm hex bit, unscrew the M4 screws and remove the IMU mounting plate, bracket and cable harness, as shown in *Figure 107: Remove IMU Mounting Plate and Bracket* on the next page:

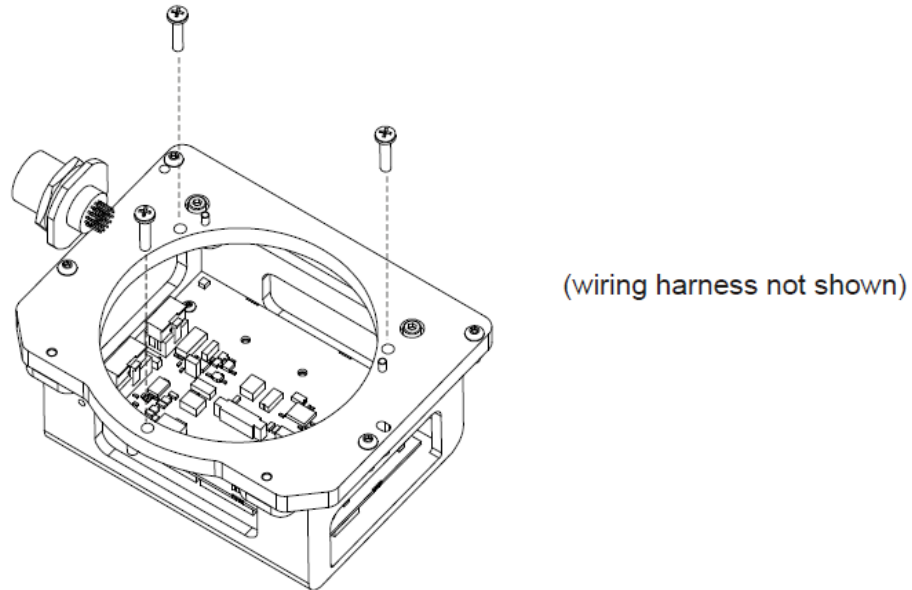
**Figure 107: Remove IMU Mounting Plate and Bracket**



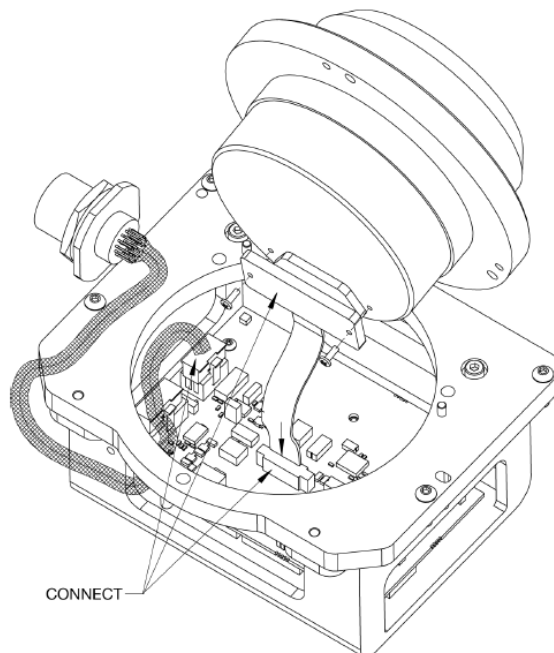
## **B.2 Install the HG1700 Sensor Unit**

To install the HG1700 sensor unit in the Universal Enclosure:

1. Using a Phillips screwdriver, remove the 8-32 IMU mounting screws from the IMU mounting plate, as shown in *Figure 108: Remove IMU Mounting Screws* on the next page.

**Figure 108: Remove IMU Mounting Screws**

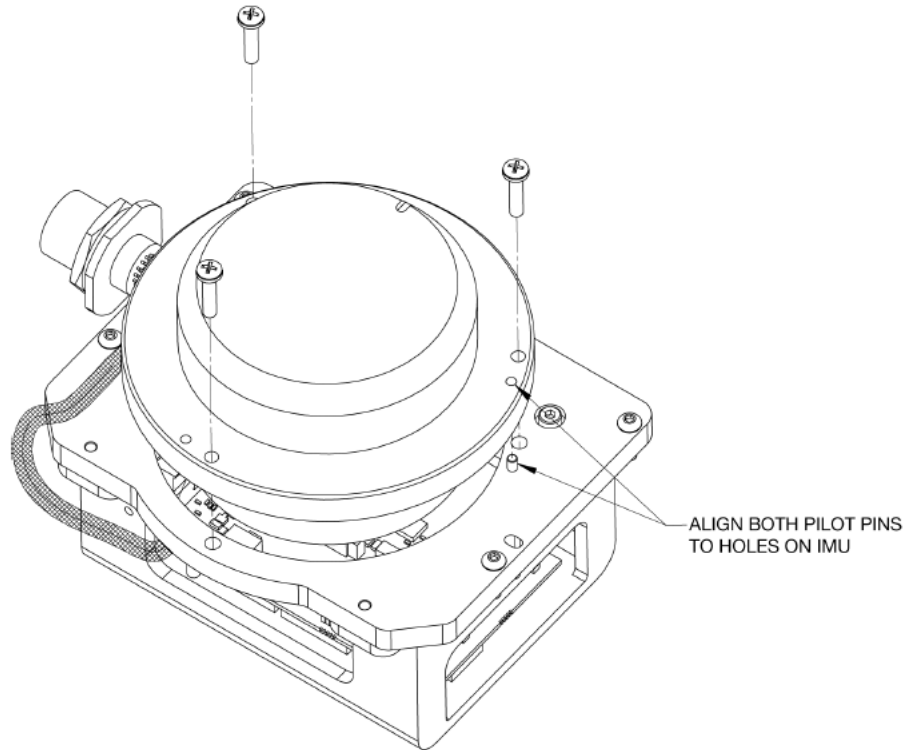
2. Check the connection of the internal cable harness to the board assembly and route as shown in *Figure 109: Connect IMU to IMU Mounting Plate* below. Before you connect the IMU cable harness, make sure the connector on the board assembly is clicked open. Connect the IMU cable harness to the IMU (fasten the 2-56 screws but do not use thread-locking fluid), then connect to the board assembly. Ensure the cable housing latches.

**Figure 109: Connect IMU to IMU Mounting Plate**

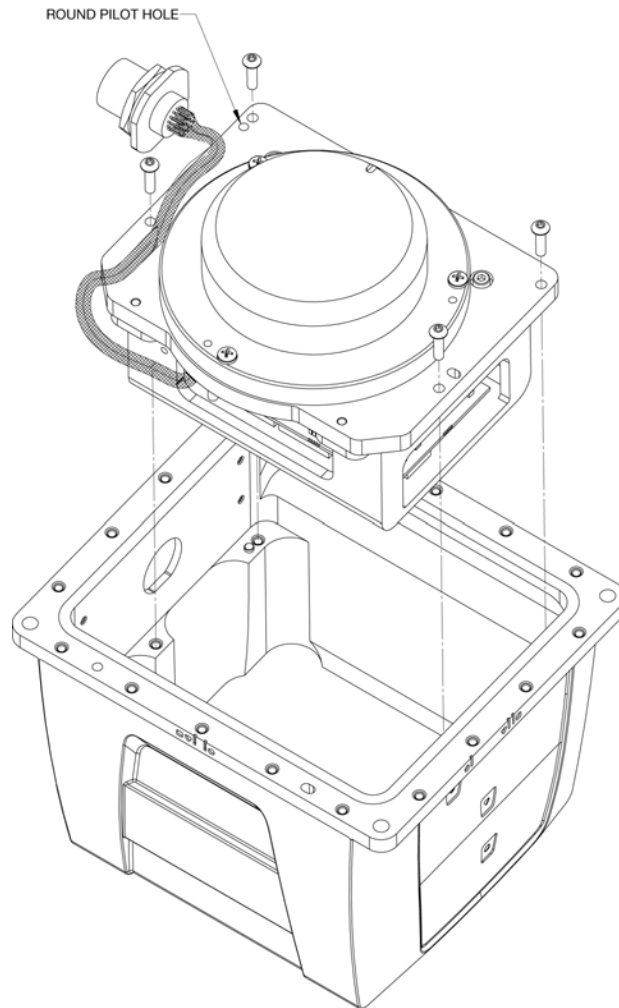
3. Being careful of the connectors and the orientation, align the pilot holes of the IMU with the pilot pins of the mounting plate. Gently place the IMU and mounting plate together, being careful not to pinch the cable

harness. Screw the IMU and mounting plate together, using thread-locking fluid on the 8-32 screws, as shown in *Figure 110: Installing IMU to Mounting Plate* below.

**Figure 110: Installing IMU to Mounting Plate**

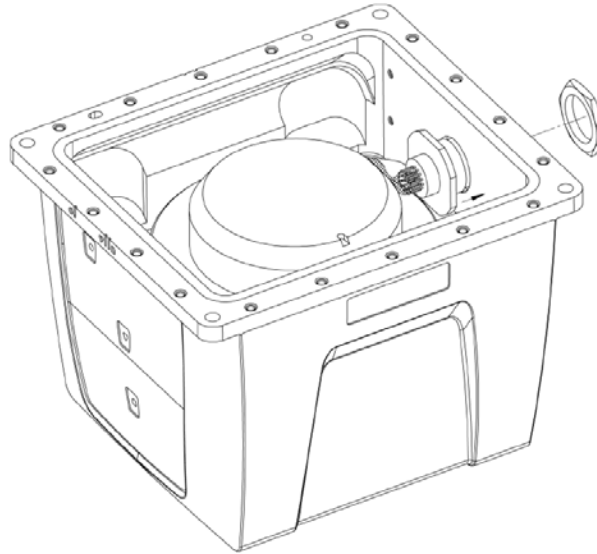


4. Starting with the round pilot hole, shown in *Figure 111: Assemble Into Enclosure Body* on the next page, align the pilot holes of the assembled plate (noting the orientation) with the pilot pins of the enclosure body. Lower the assembly into place, then fasten using thread-locking fluid on the M4 screws.

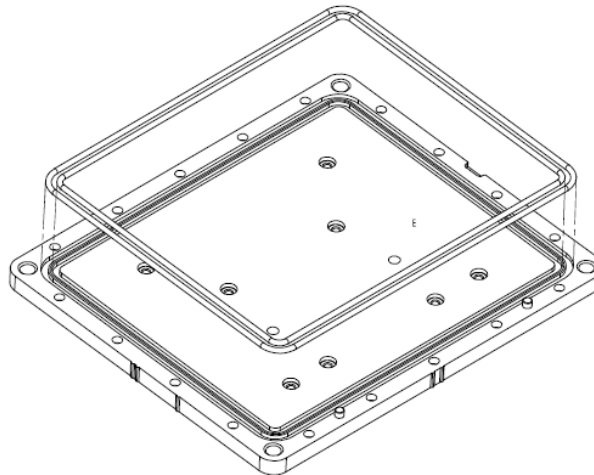
**Figure 111: Assemble Into Enclosure Body**

5. Connect the internal cable harness to the enclosure body, as shown in *Figure 112: Fasten Internal Cable Harness* on the next page. During this step, ensure the connector O-ring (supplied with the connector of the internal cable harness) remains flat within the connector's groove, and make sure the groove is clean and free of debris. Fasten the connector to the enclosure body wall using the jam nut supplied with the connector. Apply thread-locking fluid then, with a 30 mm socket, tighten the jam nut to 6.9 N-m (61 lb-in/5.1 lb-ft).

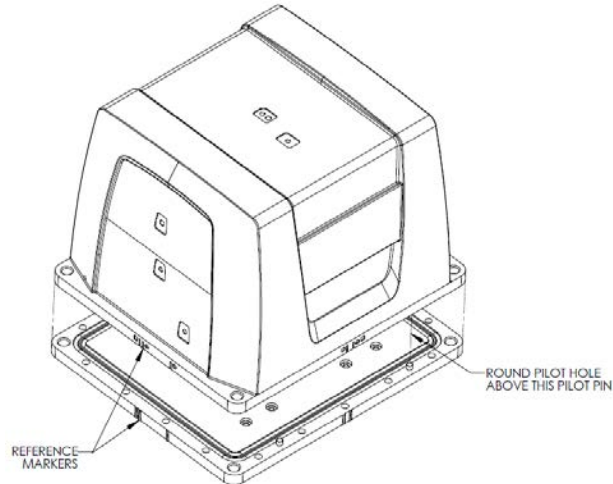


**Figure 112: Fasten Internal Cable Harness**

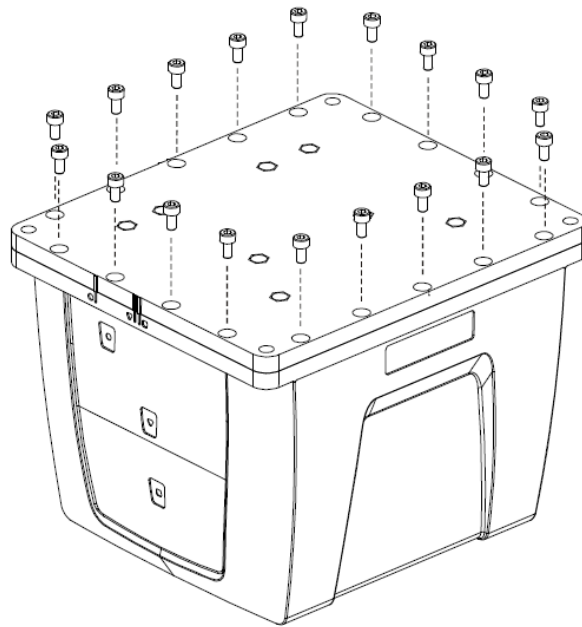
6. Ensure the O-rings are in place. If they are not, as necessary, make sure the grooves of the enclosure base are clean and free of debris, using isopropyl alcohol. As shown in *Figure 113: Install O-rings* below, install the outer environmental and inner EMI O-rings in the enclosure base, being careful not to stretch or twist them. O-rings must remain flat within the grooves during the remainder of the assembly procedure.

**Figure 113: Install O-rings**

7. Clean the surface of the enclosure body, where it mates with the O-rings, using isopropyl alcohol. As shown in *Figure 114: Install Enclosure Body on the Base* on the next page, align the reference markers and pilot holes/pins of the enclosure body and base. Carefully lower the body onto the base, observing the O-rings and alignment of corners. Press the enclosure body into place, starting with the round pilot hole indicated in *Figure 114: Install Enclosure Body on the Base* on the next page.

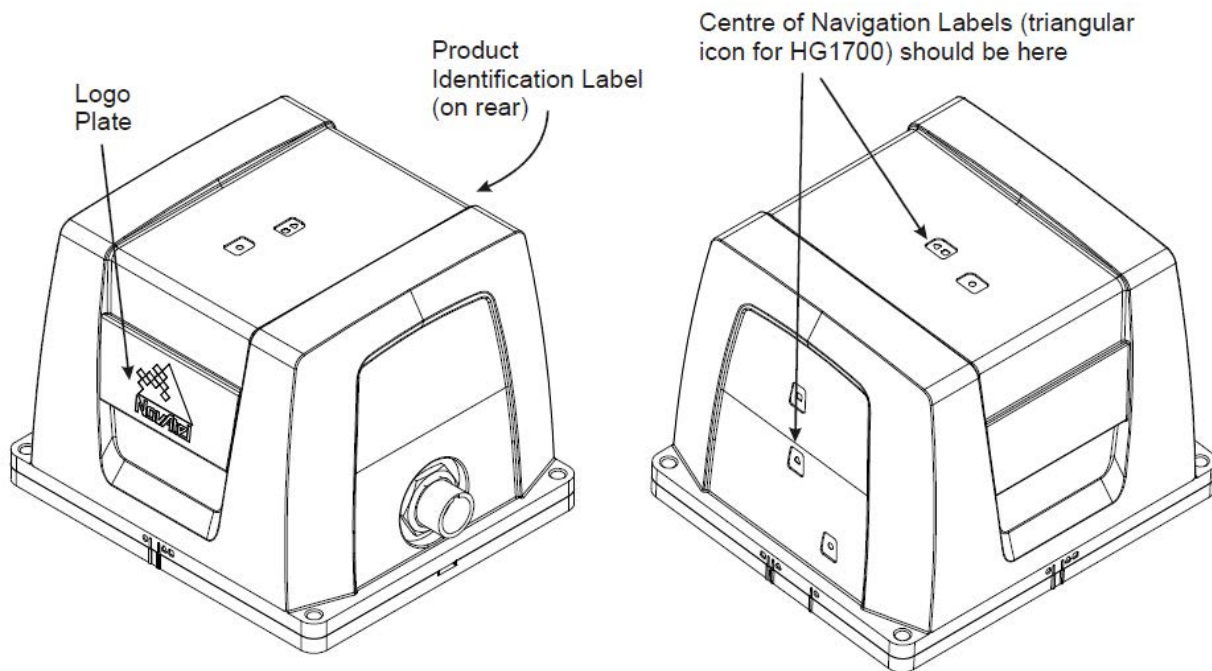
**Figure 114: Install Enclosure Body on the Base**

8. While squeezing and holding the enclosure body and base together to maintain tight contact, carefully turn the assembly over and place it on its top, as shown in *Figure 115: Screw Enclosure Base to Body* below. Using a 3 mm hex bit, lightly fasten four equally spaced M4 screws to hold the parts together. Apply thread-locking fluid to each screw before inserting. Install the remaining screws in similar fashion. Tighten all screws then check all of them again for tightness. Tighten these screws to 1.36-1.58 N-m (12-14 lb-in). Do not over-tighten.

**Figure 115: Screw Enclosure Base to Body**

9. Ensure the product identification label, the logo plate and the center of navigation labels are properly affixed and contain the correct information. The final assembled unit will be similar to that shown in *Figure 116: Final Assembly* on the next page.

**Figure 116: Final Assembly**



# APPENDIX C LN-200 IMU in Universal Enclosure

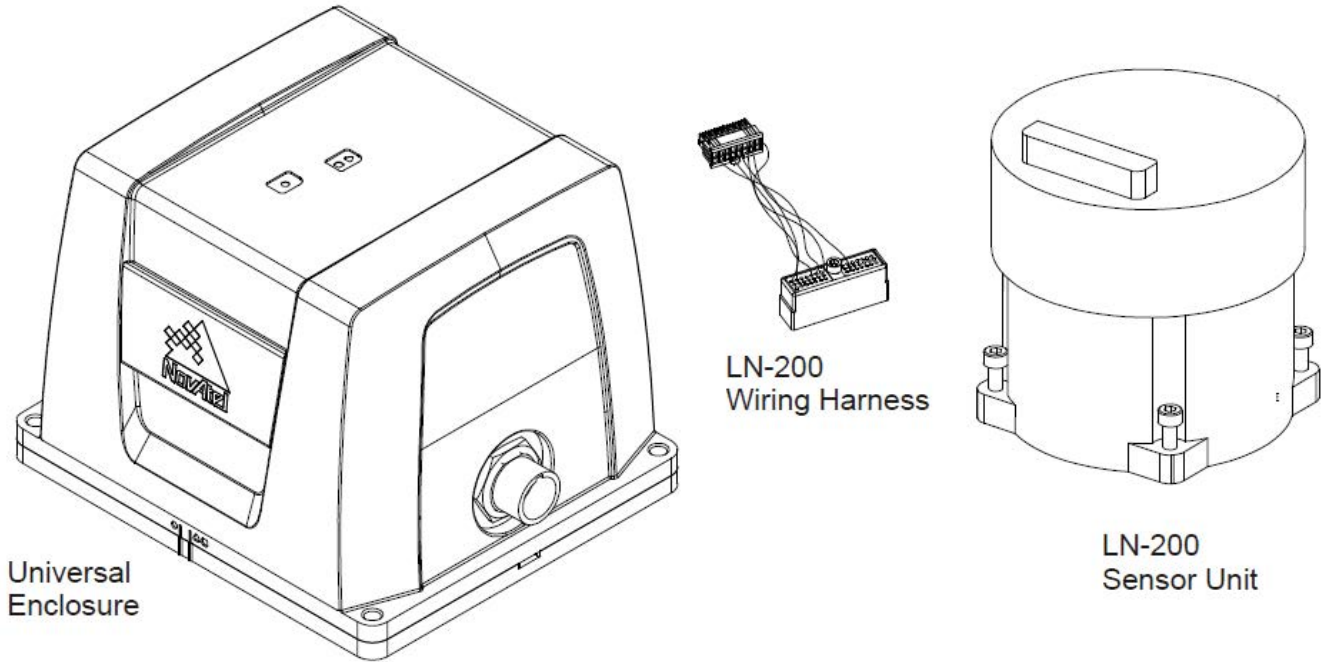


**Important!** Assemble in accordance with applicable industry standards. Ensure all ESD measures are in place, in particular, use a ground strap before exposing or handling any electronic items, including the IMU. Take care to prevent damaging or marring painted surfaces, O-rings, sealing surfaces, and the IMU.

The following procedure provides the necessary information to install the LN-200 sensor into the Universal Enclosure (NovAtel part number 01018590), both illustrated below. The steps required for this procedure are:

- Disassemble the Universal Enclosure
- Install the LN-200 Sensor Unit
- Reassemble the Universal Enclosure

**Figure 117: Required Parts**



Use thread-locking fluid on all fasteners except for the cable harness connectors.



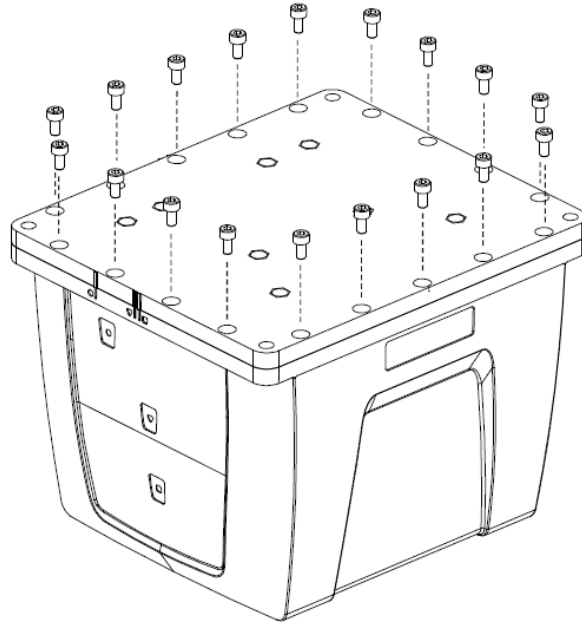
Torque values for all fasteners, including those for the cable harness screws, are as follows:  
Size 6-32: 0.79-0.90 N-m (7.0-8.0 lb-in)  
Size M4: 1.36-1.58 N-m (12.0-14.0 lb-in)

## C.1 Disassemble the Universal Enclosure

Disassemble the Universal Enclosure as follows:

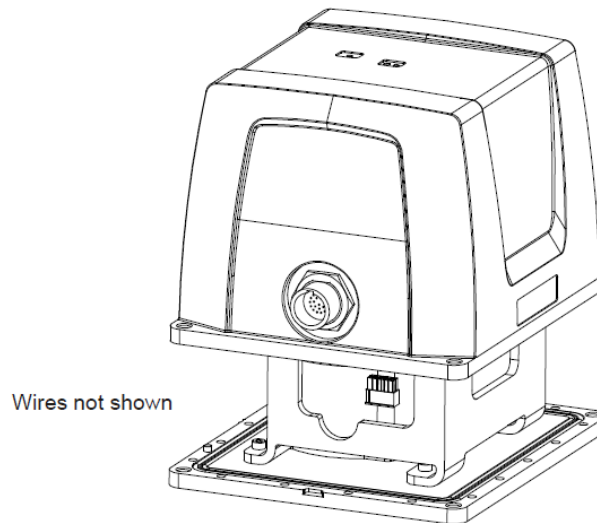
1. Using a 3 mm hex bit, remove the M4 screws (they will be reused) and the base, as shown in *Figure 118: Remove Base* below.

**Figure 118: Remove Base**



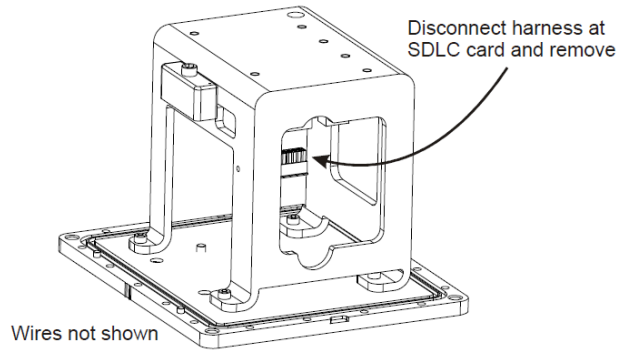
2. While squeezing and holding the assembly tightly together, carefully turn the assembly over and set it down as shown in *Figure 119: Disconnect Wiring Harness from SDLC Card* below. Raise the enclosure body, and disconnect the internal cable harness at the SDLC board. Ensure the O-rings remain with the base when it is removed, and that they are not damaged.

**Figure 119: Disconnect Wiring Harness from SDLC Card**



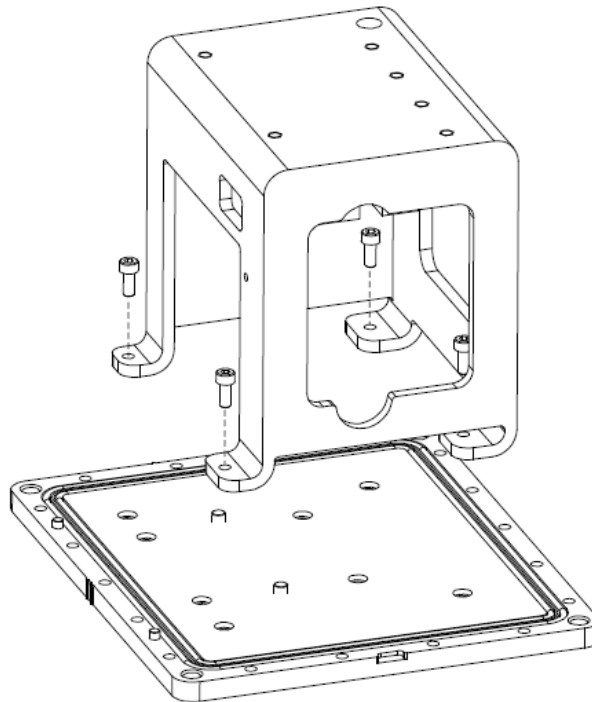
3. Lift the enclosure lid off the assembly to expose the IMU bracket, shown in *Figure 120: IMU Bracket* on the next page. Disconnect the harness at the SDLC card and remove.

**Figure 120: IMU Bracket**



4. Using a 3 mm hex bit, unscrew 4 mm screws and remove the IMU bracket with SDLC, as shown in *Figure 121: Remove IMU Bracket/SDLC* below.

**Figure 121: Remove IMU Bracket/SDLC**

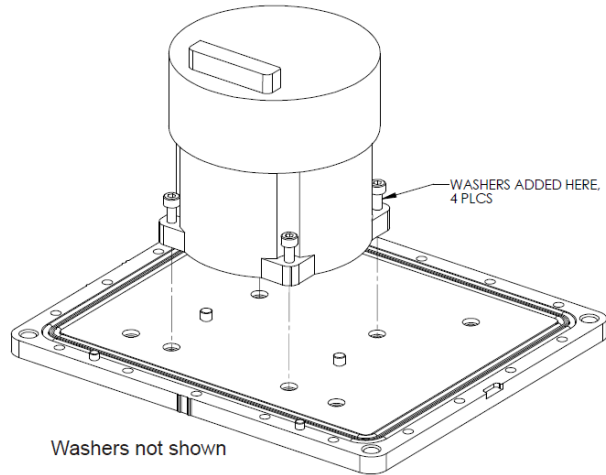


## C.2 Install the LN-200 Sensor Unit

To install the LN-200 sensor unit in the Universal Enclosure:

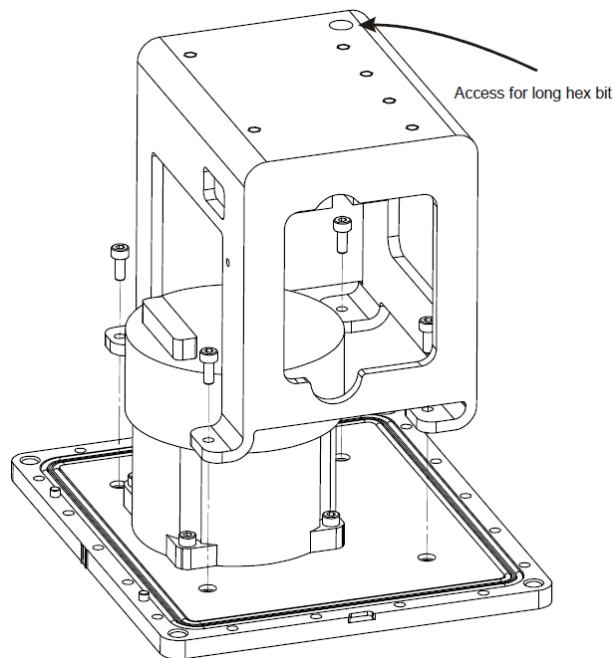
1. Using a 3 mm hex bit, remove original captive 6-32 screws and washers (4 each) from the LN-200 IMU. Add three washers under each of the original washers and fasten the IMU to the enclosure base, as shown in *Figure 122: Install LN-200 IMU to Base* on the next page. Use thread-locking fluid on each screw.

**Figure 122: Install LN-200 IMU to Base**



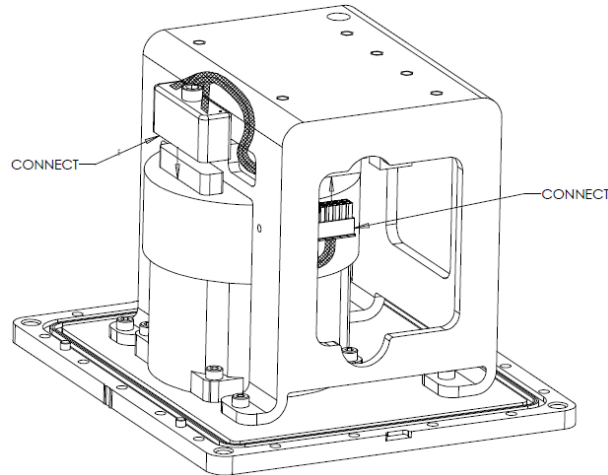
2. Using a long 3 mm hex bit, install the IMU bracket/SDLC to the base, as shown in *Figure 123: Install Bracket to Base* below. Use thread-locking fluid on each M4 screw.

**Figure 123: Install Bracket to Base**



3. Connect the cable harness to the board assembly and IMU, routing it as shown in *Figure 124: Making Connections* on the next page. Ensure latching of the cable connector housings and fasten the 6-32 screw at the IMU end using a 5/32" hex bit. Do not use thread-locking fluid and do not overtighten.

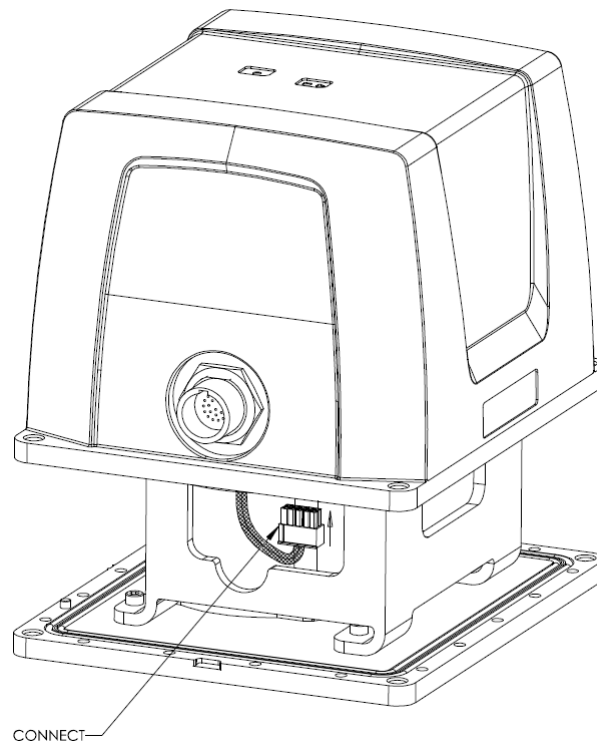
**Figure 124: Making Connections**



Make sure the tape of the harness is positioned for maximum protection.

4. While carefully holding the body over the bracket, connect the internal cable harness to the board assembly, as shown in *Figure 125: Connect Internal Cable Harness* below.

**Figure 125: Connect Internal Cable Harness**

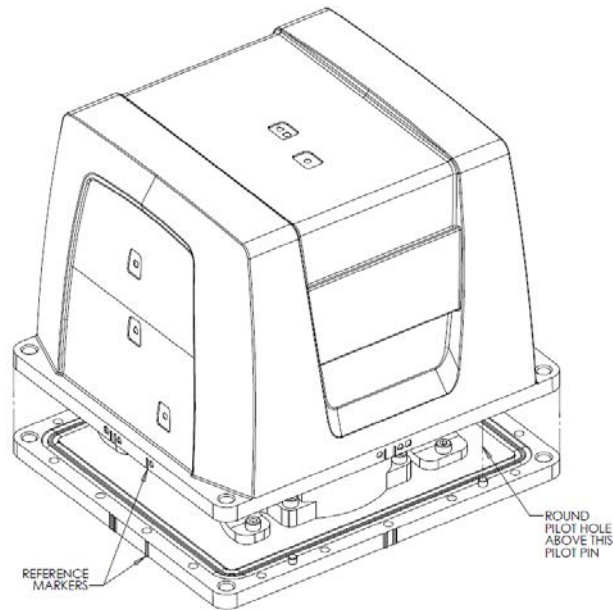


5. Clean the surface of the enclosure body, where it will mate with the O-rings, using isopropyl alcohol. While ensuring all wires will fit inside the bracket without being pinched, align the reference markers and pilot holes/screws of the enclosure body and base, and carefully lower the body onto the base, observing the O-



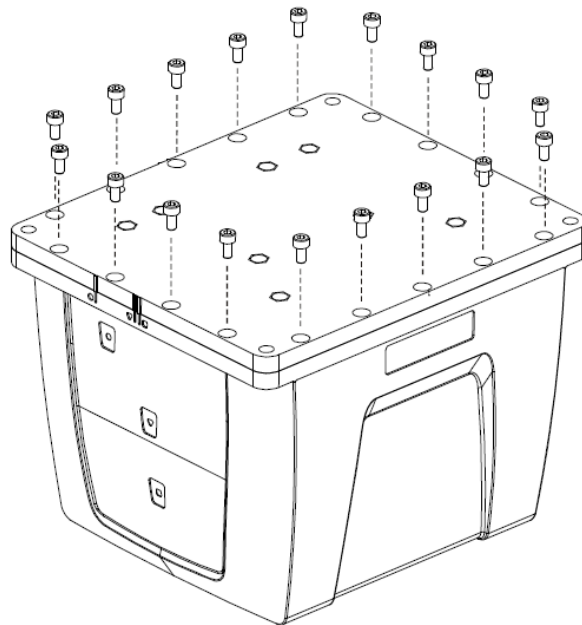
rings and the alignment of corners. Start with the round pilot hole indicated in *Figure 126: Installing the Enclosure Body to the Base* below, then press the assembly into place.

**Figure 126: Installing the Enclosure Body to the Base**



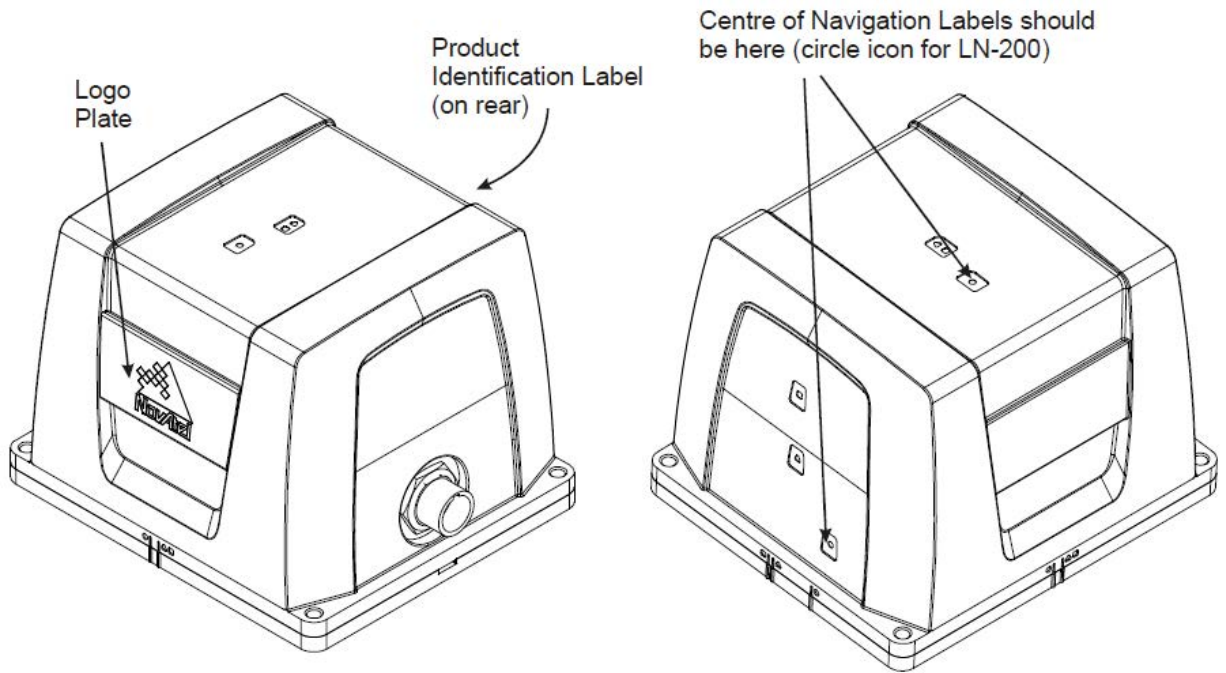
6. While squeezing and holding the enclosure body and base together to maintain tight contact, carefully turn the assembly over and place it on its top, as shown in *Figure 127: Screw Enclosure Base to Body* below. Using a 3 mm hex bit, lightly fasten four equally spaced M4 screws to hold the parts together. Use thread-locking fluid on all screws. Install the remaining screws in similar fashion. Tighten all screws to 1.36-1.58 N-m (12-14 lb-in). Do not over-tighten.

**Figure 127: Screw Enclosure Base to Body**



7. Ensure the product identification label, the logo plate and the center of navigation labels are properly affixed and contain the correct information. The final assembled unit is shown in *Figure 128: Final Assembly* below.

**Figure 128: Final Assembly**



# APPENDIX D HG1700 IMU in SPAN HG Enclosure

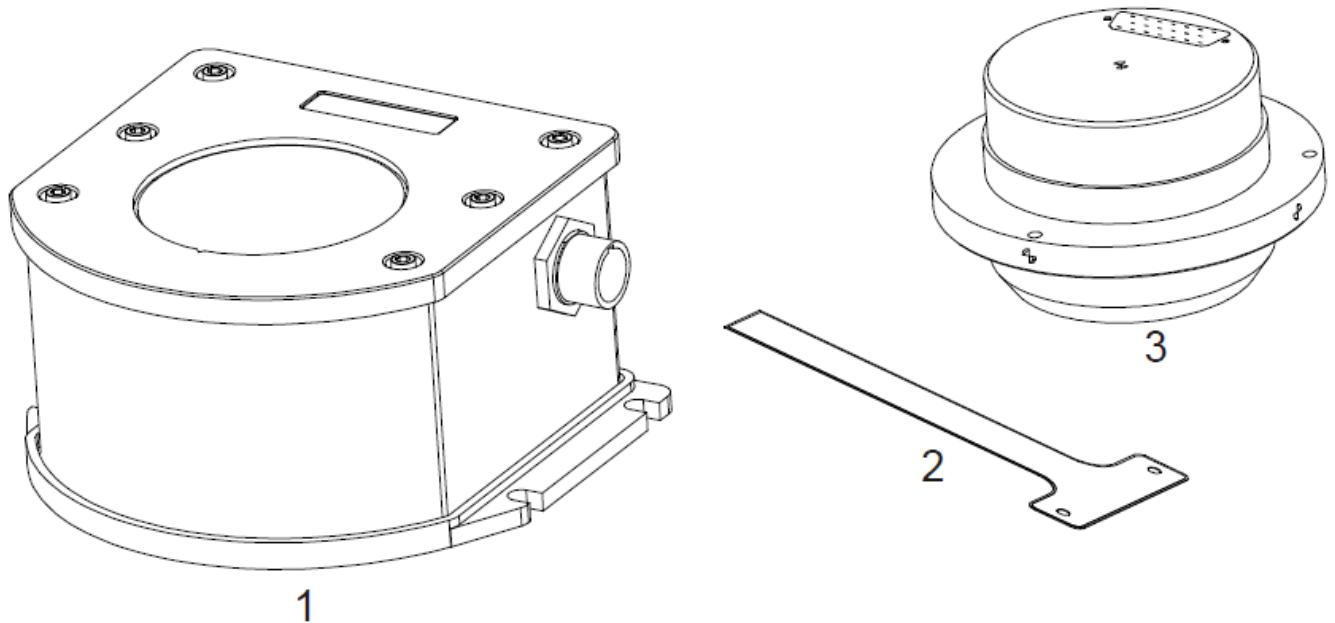
The following procedure provides the necessary information to install the HG1700 sensor into the SPAN HG Enclosure (NovAtel part number 01017898). The steps required for this procedure are:

- Disassemble the SPAN HG Enclosure
- Install the HG1700 Sensor Unit
- Make Electrical Connections
- Reassemble the SPAN HG Enclosure



Ensure you use a ground strap before installing the internal circuit boards. Do NOT scratch any surfaces of the unit.

Figure 129: Required Parts



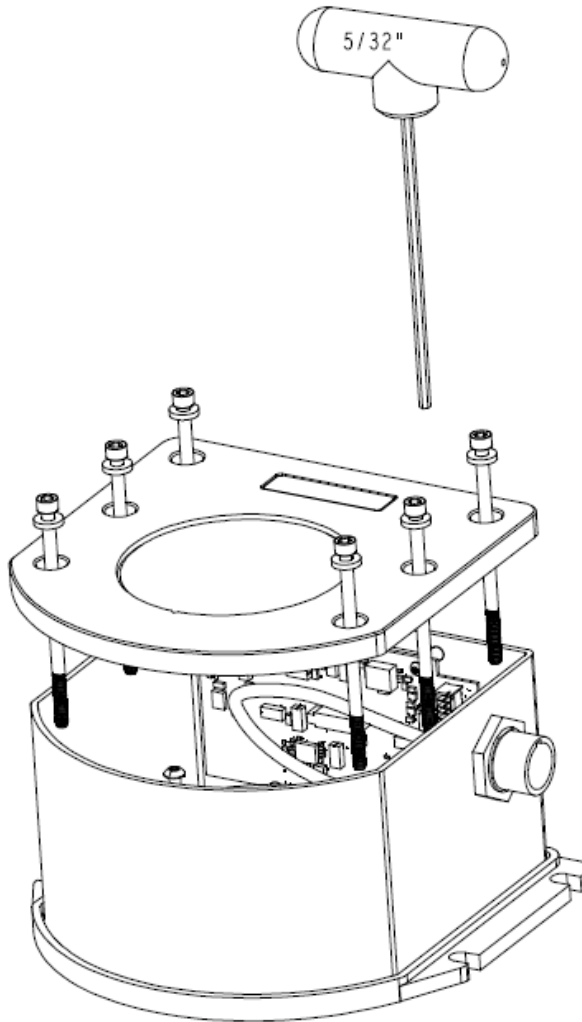
Reference	Description
1	SPAN IMU Enclosure
2	HG1700 Flex Cable
3	HG1700 Sensor Unit

## D.1 Disassemble the SPAN IMU Enclosure

The SPAN IMU assemblyman steps are as follows:

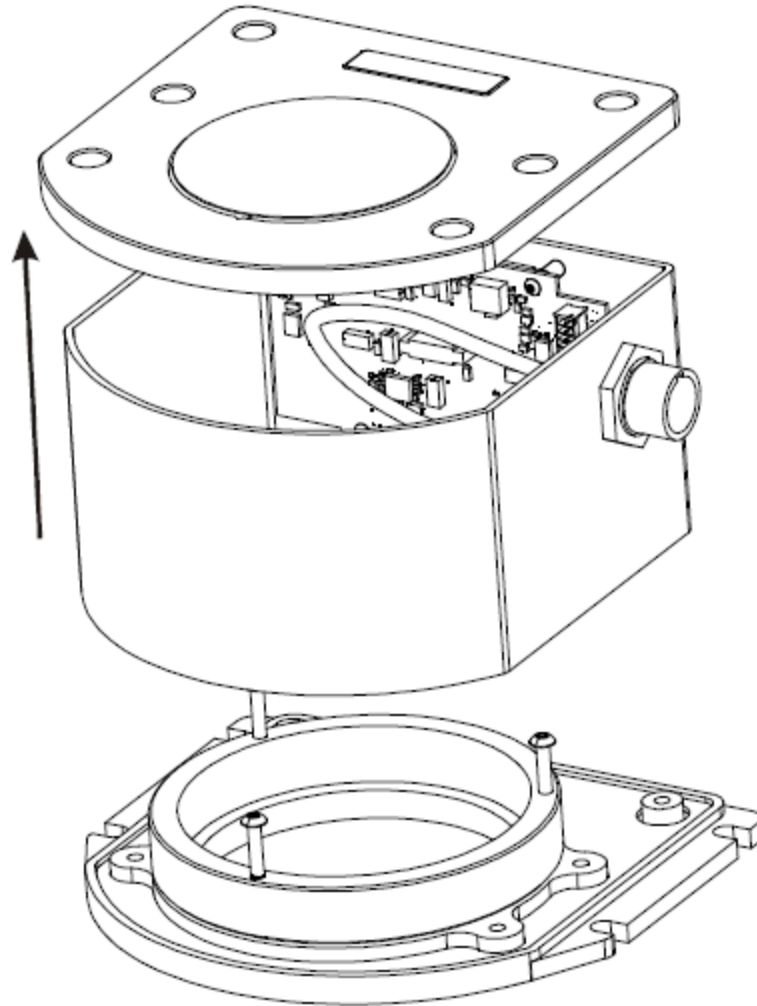
1. Remove the six bolts from the top cover using a hex key, as shown in *Figure 130: Bolts and Hex Key* on the next page:

**Figure 130: Bolts and Hex Key**



2. Set aside the bolts with their sealing washers.
3. Lift the top cover off the tube body and set it aside, as shown in *Figure 131: Lift Top Cover, Tube Body and 3 Ring Spacer Screws* on the next page.
4. Lift the tube body away from its base plate and set it aside.
5. Remove the 3 ring spacer screws and set them aside.

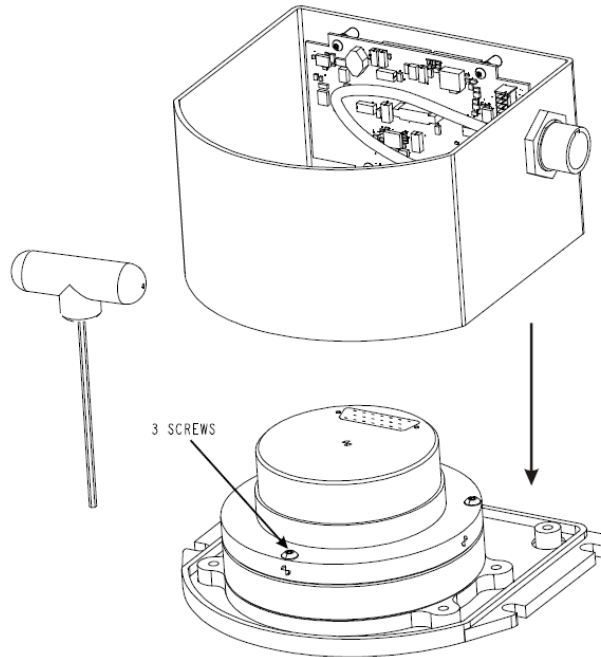
**Figure 131: Lift Top Cover, Tube Body and 3 Ring Spacer Screws**



## D.2 Install the HG1700 Sensor Unit

To re-assemble the SPAN IMU with the HG1700 sensor, see *Figure 132: SPAN IMU Re-Assembly* on the next page and follow these steps:

1. Mount the HG1700 sensor with the attached #8 screws. Apply threadlock to the screw threads. Use a hex key to torque each screw to 10 in-lbs.
2. Fit the tube body over the HG1700 sensor and onto the base plate.

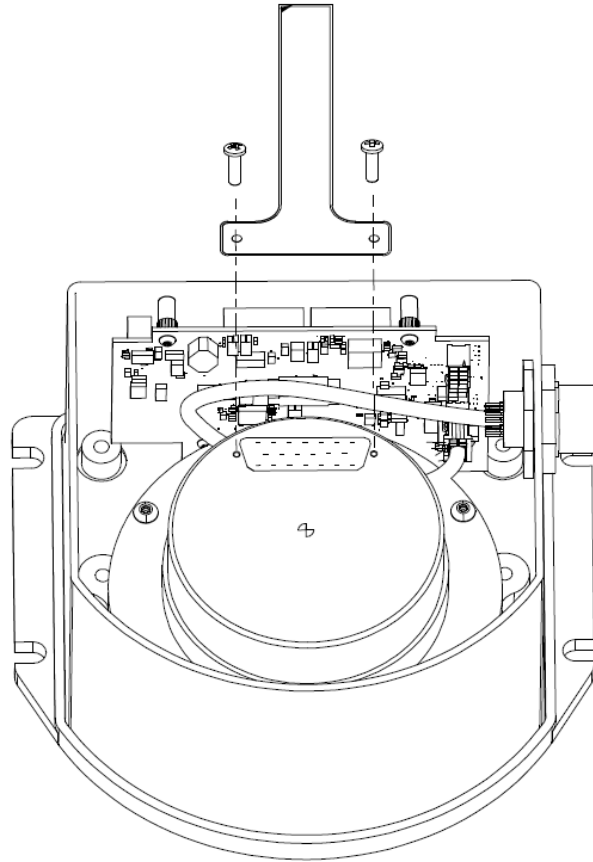
**Figure 132: SPAN IMU Re-Assembly**

### D.3 Make the Electrical Connections

To make the electrical connections you need a 3/32" hex key, the flex cable and the partially assembled SPAN IMU from *Install the HG1700 Sensor Unit* on the previous page. Now follow these steps:

1. Attach the flex cable to the HG1700 sensor ensuring that all the pins are fully connected. Check also that the pins are fully seated and that the flex cable stiffener around the pins is not bent upward, see *Figure 133: Attach Flex Cable* on the next page.

**Figure 133: Attach Flex Cable**

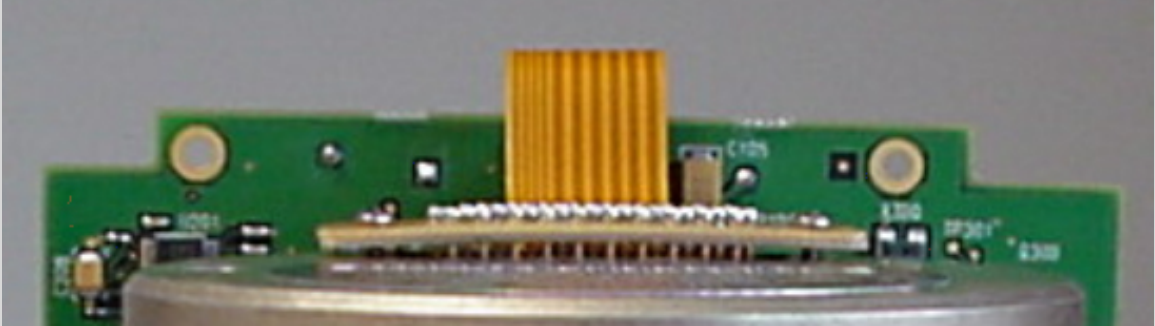


2. Tighten the screws to 4 in-lbs.
3. Connect the opposite end of the flex cable to the corresponding connector on the IMU card ensuring that the contacts on the flex cable mate with the contacts on the connector, as shown in *Figure 133: Attach Flex Cable* above.
4. Check that the flex cable is locked in place.

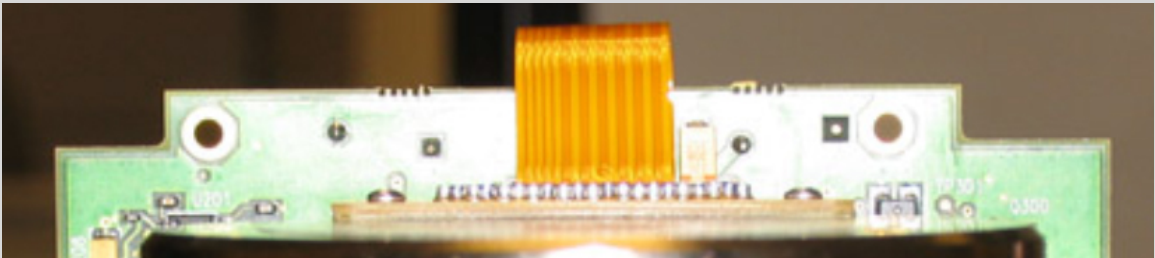


*Figure 134: Incorrect (Bowed) Flex Cable Installation* below shows an incorrect installation of the flex cable where it is bowed in the middle. It will not operate properly in this position. *Figure 135: Correct (Flat) Flex Cable Installation* below shows the proper installation of the flex cable. Notice how the flex cable sits flush against the IMU surface.

**Figure 134: Incorrect (Bowed) Flex Cable Installation**



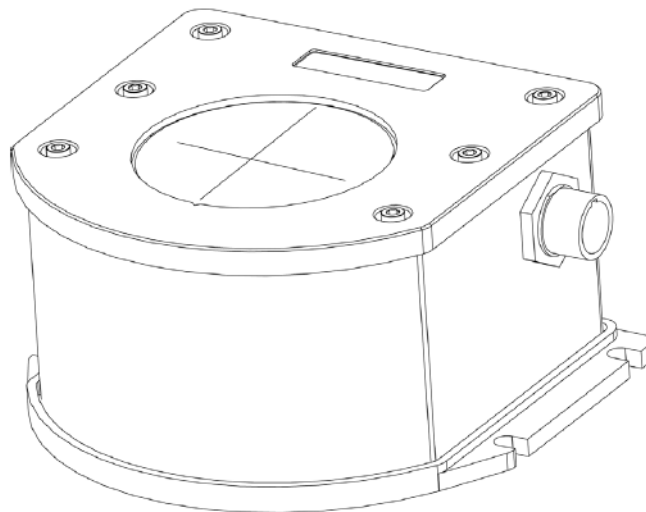
**Figure 135: Correct (Flat) Flex Cable Installation**



## D.4 Re-Assemble the SPAN IMU Enclosure

Use a hex key to align the long bolts with the threaded holes in the base, as shown in *Figure 130: Bolts and Hex Key* on page 300. Apply threadlock to threads. Finger tighten all bolts and torque them in a cross pattern to 12 in-lbs. The fully assembled IMU enclosure is shown in *Figure 136: HG1700 SPAN IMU* below.

**Figure 136: HG1700 SPAN IMU**





# APPENDIX E LN-200 IMU in SPAN IMU Enclosure

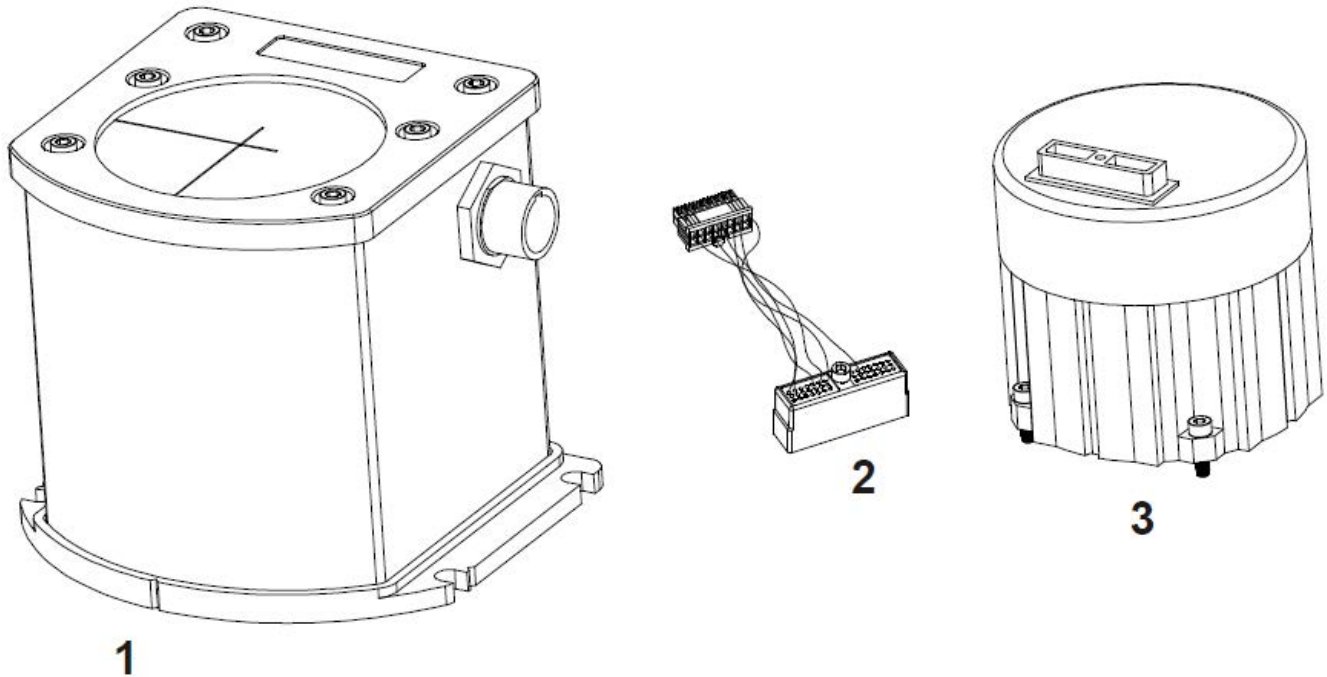
The following procedure provides the necessary information to install the LN-200 sensor (NovAtel part number 80023515) into the SPAN IMU enclosure (NovAtel part number 01017656) using the LN-200 wiring harness (NovAtel part number 01017655). The steps required for this procedure are:

- Disassemble the SPAN IMU Enclosure
- Install the LN-200 Sensor Unit
- Make Electrical Connections
- Reassemble the SPAN IMU Enclosure



**Important!** Ensure you use a ground strap before installing the internal circuit boards. Do NOT scratch any surfaces of the unit.

Figure 137: Required Parts



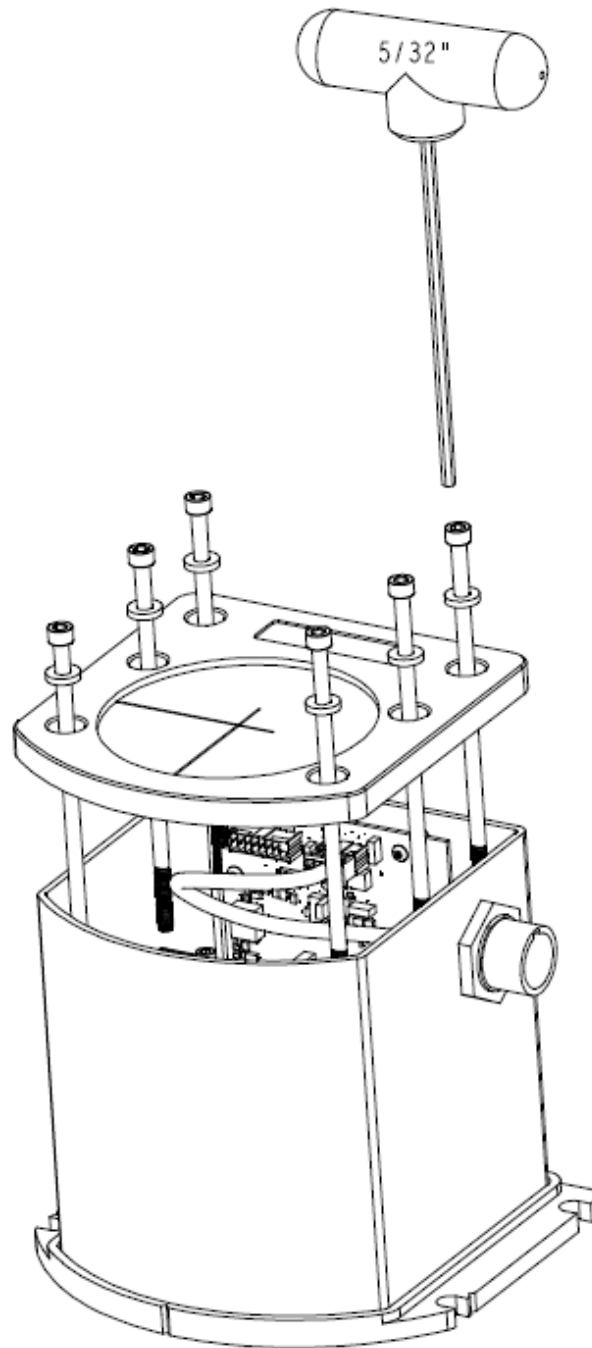
Reference	Description
1	SPAN IMU Enclosure
2	LN-200 Wiring Harness
3	LN-200 Sensor Unit

## E.1 Disassemble the SPAN IMU Enclosure

The SPAN IMU disassembly steps are as follows:

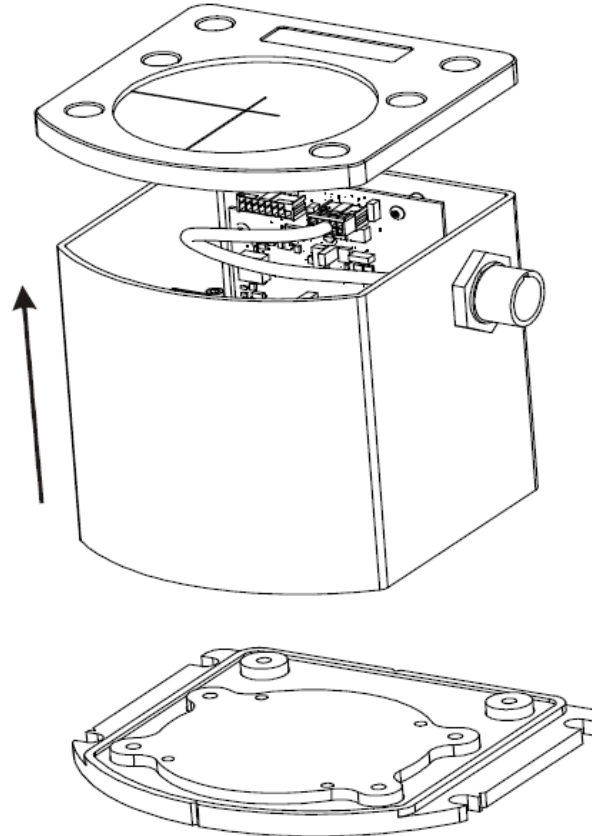
1. Remove the six bolts from the top cover using a hex key, as shown in *Figure 138: Bolts and Hex Key* on the next page:

**Figure 138: Bolts and Hex Key**



2. Set aside the bolts with their sealing washers.
3. Lift the top cover off the tube body and set it aside.
4. Lift the tube body away from its base plate and set it aside, as shown in *Figure 139: Lift Top Cover and Tube Body* on the next page.

**Figure 139: Lift Top Cover and Tube Body**

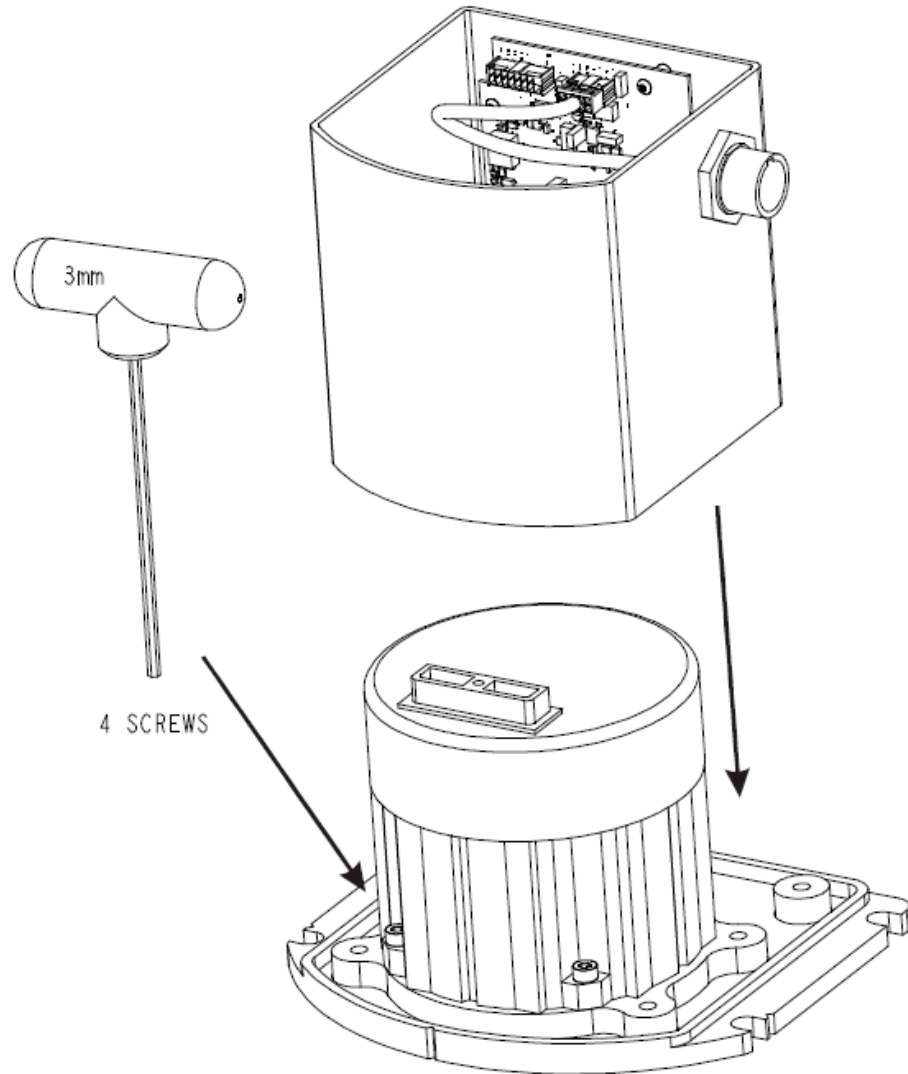


## **E.2 Install the LN-200 Sensor Unit**

To install the LN-200 sensor, follow these steps:

1. Mount the LN-200 sensor with the attached M4 screws. Apply threadlock to the screw threads. Use a hex key to torque each screw to 10 in-lbs.
2. Fit the tube body over the LN-200 sensor and onto the base plate.

Figure 140: SPAN IMU Re-Assembly

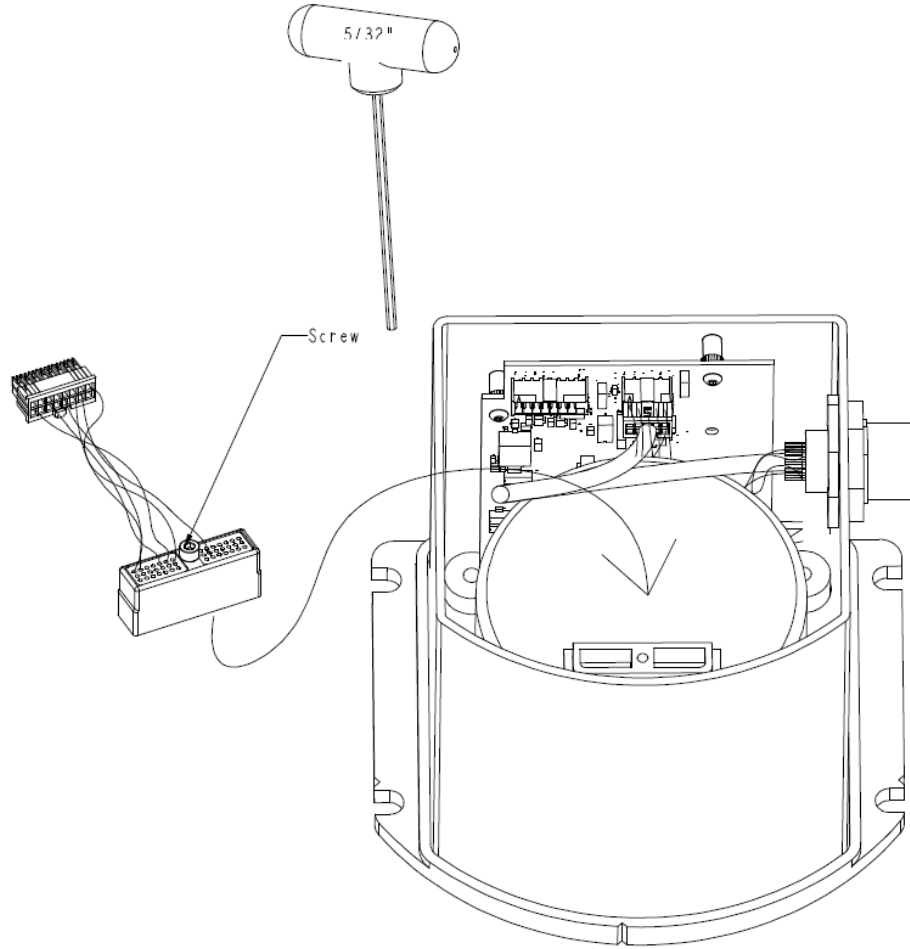


### E.3 Make the Electrical Connections

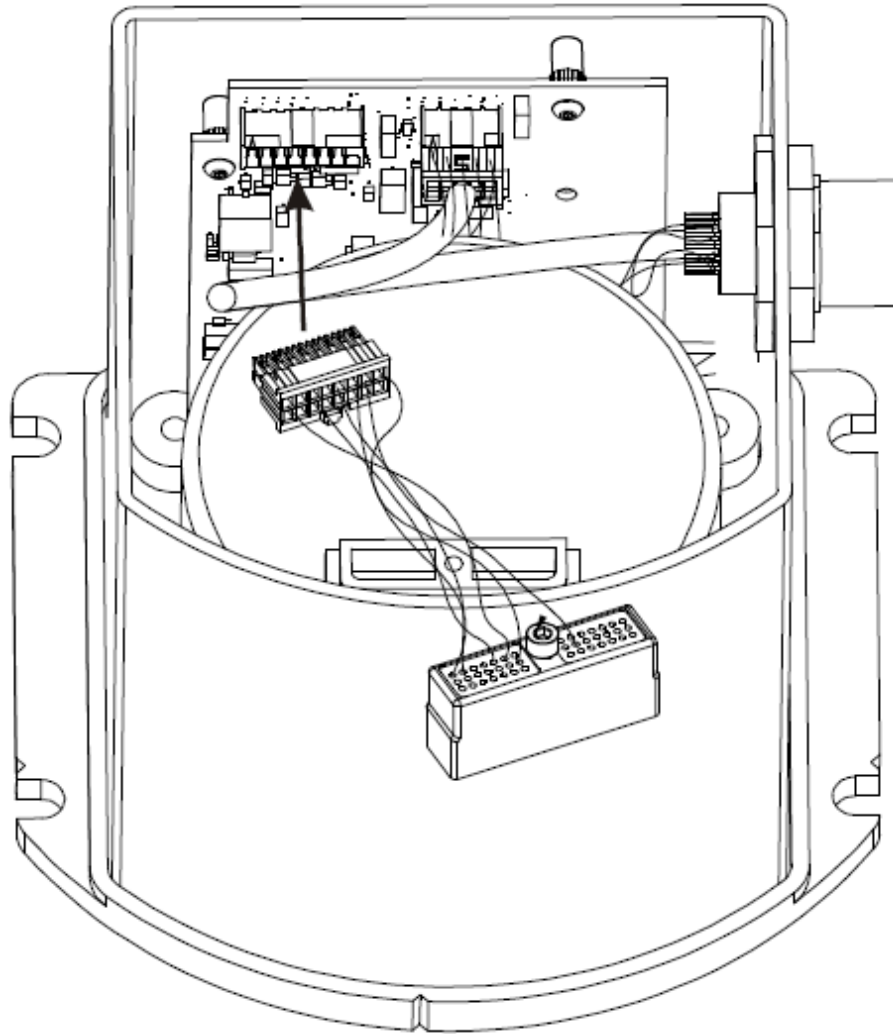
To make the electrical connections you will need a 3/32" hex key, the wiring harness and the partially assembled SPAN IMU from *Install the LN-200 Sensor Unit* on the previous page. Now follow these steps:

1. Attach the LN-200 wire harness to the mating connector on the LN-200. Check that the connector is fully seated, as shown in *Figure 141: Attach Wiring Harness* on the next page.

**Figure 141: Attach Wiring Harness**



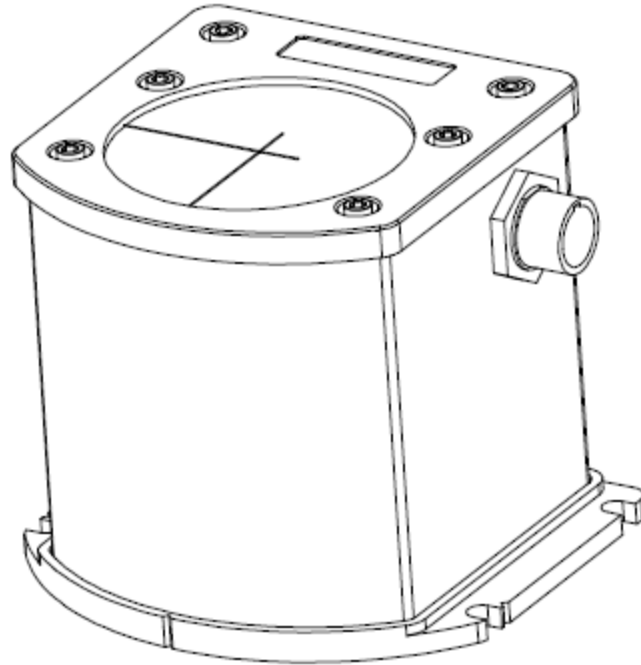
2. Connect the Samtec connector at the other end of the wiring harness to the corresponding connector on the internal IMU card, as shown in *Figure 142: Attach Samtec Connector* on the next page. Ensure that the connector is locked in place.

**Figure 142: Attach Samtec Connector**

#### **E.4 Re-Assemble the SPAN IMU Enclosure**

Use a hex key to align the long bolts with the threaded holes in the base, as shown in *Figure 138: Bolts and Hex Key* on page 306. Apply threadlock to threads. Finger tighten the 6 bolts then torque them in a cross pattern to 12 in-lbs. The fully assembled IMU enclosure is shown in *Figure 143: LN-200 SPAN IMU* on the next page.

**Figure 143: LN-200 SPAN IMU**



## APPENDIX F Frequently Asked Questions

1. How do I know if my IMU is connected properly?
  - a. Refer to the **VERSION** log. If your IMU is communicating with a SPAN enabled receiver, the IMU details will be included in the log.
  - b. When powered, the HG-1700 IMU makes a noticeable humming sound. If no sound is heard, check that the cable between the receiver and IMU is connected properly.
  - c. Most IMUs do not make noise. Check that the IMU interface cable is properly connected to the receiver.  
For the IMU-ISA-100C, IMU-FSAS, IMU-CPT, IMU-HG1900, IMU-ENC-LN200, IMU- $\mu$ IMU-IC and IMU-KVH1750, ensure the IMU interface cable is connected to an RS-422 capable port and the port is configured to use RS-422.
  - d. If the cable is connected properly, check the flex cable mounted on top of the IMU. Refer to the instructions in this manual on proper IMU installation to ensure that the cable is seated properly on the IMU pins. See *HG1700 IMU in Universal Enclosure* on page 283 or *LN-200 IMU in Universal Enclosure* on page 292 for more details.
  - e. Check the input power supply. A minimum of 12V should be supplied to the system for stable IMU performance. The supply should also be able to output at least 12W over the entire operating temperature range.
2. What is the minimum configuration I need to do to get the system running?
  - a. Set the IMU type and IMU communication port with the **CONNECTIMU** command.
  - b. Specify the translational offset between the IMU center of navigation and the primary GNSS antenna phase center with the **SETINSTRANSLATION** command.
  - c. Specify the rotational offset between the IMU Body frame and the Vehicle frame, with the **SETINSROTATION** command.

3. What types of IMUs are supported?

SPAN currently supports the following IMUs:

- ADIS-16488 from Analog Devices
- EG320N and EG370N from Epson
- HG1700, HG1900, HG1930 and HG4930 from Honeywell
- IMU-FSAS for iMar
- IMU-KVH1750 and IMU-CPT from KVH
- ISA-100C and  $\mu$ IMU from Northrop Grumman LITEF
- LN-200 from Litton
- STIM300 from Sensoror

Use the **CONNECTIMU** command to specify the type of IMU used.

4. Why don't I have any INS data?
  - a. By default, the raw IMU data begins flowing at system start up. If there is no INS data, check that the system has been configured properly.



- b. If the **INSCOMMAND** command has been set to **START\_FINE\_TIME**, the RAWIMU logs are not available until the system has solved for time. This requires that an antenna is attached and satellites are visible to the system. You can verify that time is solved by checking the time status in the header of any standard header log such as BESTPOS. When the time status reaches FINETIME, the inertial filter starts and IMU data is available.

5. How can I access the inertial solution?

The GNSS+INS solution is available from a number of specific logs dedicated to the inertial filter. The **INSPOS** log, **INSPVA** log, **INSVEL** log, **INSSPD** log and **INSATT** log are the most commonly used logs for extracting the INS solution. These logs can be logged at any rate up to the rate of the IMU data (100, 125 or 200 Hz depending on your IMU model). The solution can also be triggered by the mark input signal by requesting the **MARKxPVA** logs.

6. Can I still access the GNSS-only solution while running SPAN?

The GNSS only solution used when running the OEM7 receiver without the IMU is still available when running SPAN. Logs such as the **PSRPOS** log and **RTKPOS** log are still available. The **BESTGNSSPOS** log is also available to provide the best available GNSS only solution. Any non-INS logs should be logged at a maximum rate of 5 Hz when running SPAN. Only INS-specific logs should be logged at rates higher than 5 Hz when running SPAN.

7. What will happen to the INS solution when I lose GNSS satellite visibility?

When GNSS tracking is interrupted, the INS solution bridges through the gaps with what is referred to as free-inertial navigation. The IMU measurements are used to propagate the solution. Errors in the IMU measurements accumulate over time to degrade the solution accuracy. For example, after one minute of GNSS outage, the horizontal position accuracy is approximately 2.5 m when using an HG1700 AG58. The SPAN solution continues to be computed for as long as the GNSS outage lasts, but the solution uncertainty increases with time. This uncertainty can be monitored using the **INSSTDEV** log or **INSSTDEVS** log.

8. Why can SPAN not align with my IMU-KVH1750?

SPAN requires that the IMU-KVH1750 be configured with non-default settings. If you have obtained your IMU-KVH1750 directly from KVH, or have manually changed the IMU configuration, refer to *KVH1750 Baud Rate Conversion* on page 54 for information about configuring the IMU for operation with SPAN.



Further details on the command and logs in this section are available in the [OEM7 Commands and Logs Reference Manual](#).

## APPENDIX G Importance of Antenna Selection

An antenna behaves both as a spatial and frequency filter, therefore, selecting the right GNSS antenna is critical for optimizing performance. An antenna must match the receiver's capabilities and specifications, as well as meet size, weight, environmental and mechanical specifications for the intended application.

Factors to consider when choosing a GNSS antenna include:

1. Constellation and signals

Each GNSS constellation and SBAS has its own signal frequencies and bandwidths. An antenna must cover the signal frequencies transmitted by the constellation and bandwidth supported by the GNSS receiver.

2. Antenna gain

Gain is a key performance indicator of a GNSS antenna. Gain can be defined as the relative measure of an antenna's ability to direct or concentrate radio frequency energy in a particular direction or pattern. A minimum gain is required to achieve a minimum carrier-to-power-noise ratio (C/No) to track GNSS satellites. The antenna gain is directly related to the overall C/No of the navigation GNSS receivers. Hence, antenna gain helps define the tracking ability of the system.

3. Element Gain

The element gain defines how efficient the antenna element is at receiving the signals. In any signal chain, you are only as good as the weakest link, so an antenna element with low element gain might be compensated by an increased low noise amplifier gain. However, the signal-to-noise ratio or C/No is still degraded.

4. Antenna beamwidth and gain roll-off

Gain roll-off is a factor of beamwidth, and specifies how much the gain changes over the elevation angle of the antenna. From the antenna's point of view, the satellites rise from the horizon towards zenith and fall back to the horizon. The variation in gain between zenith (directly overhead) and the horizon is known as the gain roll-off. Different antenna technologies have different gain roll-off characteristics.

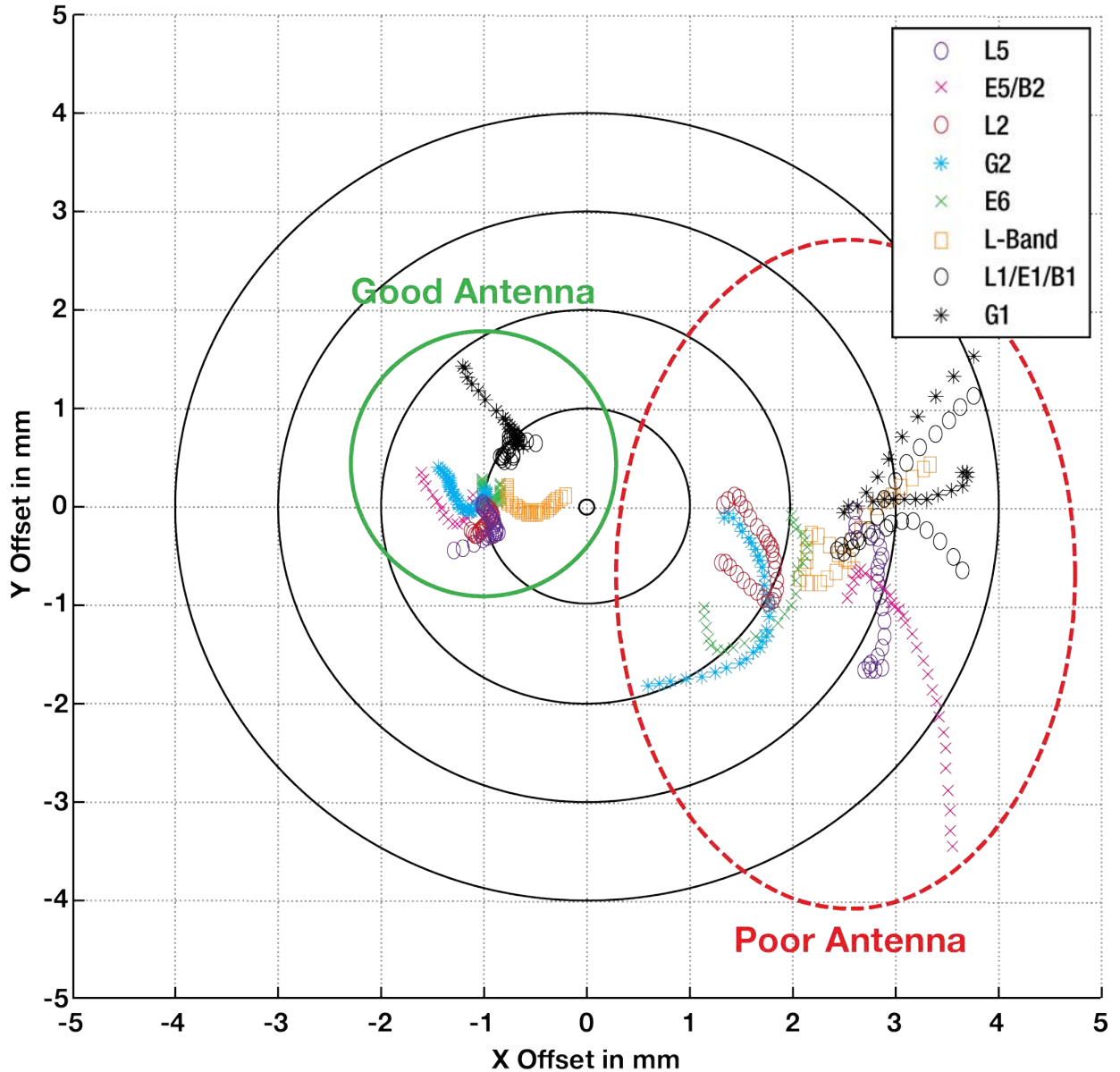
5. Phase center stability

The phase center of the antenna is the point where the signals transmitted from satellites are collected. When a receiver reports a location fix, that location is essentially the phase center of the antenna.

The electrical phase center of any antenna will vary with the position of the transmitting signal it is receiving by as much as a few millimeters. As GNSS satellites move across the sky, the electrical phase center of the signal received will typically move with the satellite position unless the antenna has been carefully designed to minimize Phase Center Offset (PCO) and Phase Center Variation (PCV).

The PCO with respect to the Antenna Reference Point (ARP) is the difference between the mechanical center of antenna rotation and electrical phase center location. The PCO is also frequency dependent which means that there can be a different offset for each signal frequency. The PCV identifies how much the phase center moves with respect to the satellite elevation angles.

Figure 144: Plot of Good and Poor Antenna Phase Center Variation over Elevation Angle 0-90°



Many users can accept accuracies of less than a meter so these small phase center variations cause a negligible amount of position error. But if you require high precision, Real Time Kinematic (RTK) receivers can achieve position accuracies of 2-4 cm and a few millimeters of phase center error translates to a 10-15% error in reported position. For RTK survey applications, geodetic grade antennas offer superior PCO/PCV performance.

6. The application

An antenna has to meet the performance, environmental, mechanical, and operational requirements of the intended application. For example, GNSS antennas used for aviation applications should ideally be TSO/FAA certified and be rugged enough to handle extreme temperatures and vibration profiles. Survey rover antennas should be able to survive rough handling by surveyors including a pole drop.

The table below highlights some of the important desirable features needed for a GNSS antenna based upon the user's application.

Desirable Feature	Survey	GIS	Reference Station	Aviation/Aerial Survey	Marine	Construction/Mining	Precision Agriculture	Vehicle Tracking	Dock Operations	Unmanned Aircraft	Unmanned Vehicle	Timing
Low Profile				•		•		•		•		
Ultra-low PCO/PCV	•		•									
Low PCO/PCV		•		•		•	•			•	•	
High Vibration				•		•	•		•	•	•	
Rugged	•	•	•			•			•			
Single Frequency												•
Multi Constellation	•	•	•	•	•	•	•		•	•	•	
Multi Frequency (RTK)	•	•	•		•	•	•		•	•	•	
L-band frequency (Correction Services)					•		•					
Narrow Bandwidth												•
Weatherproof	•	•	•	•	•	•	•	•	•	•	•	•
Corrosion Resistant			•		•	•			•			•
High Multipath Suppression	•		•		•	•	•		•		•	
Pole Mount	•	•	•		•	•			•			•
Magnetic/Surface Mount						•	•	•	•		•	
TSO/FAA Certification				•						•		
Extended Temperature Range			•	•						•		
Small Form-factor/ Lightweight		•								•		
High Altitude Operation			•	•						•		

## APPENDIX H Accessories and Replacement Parts

The following tables list the replacement parts available for your NovAtel OEM7 receiver. For assistance or to order additional components, contact your local NovAtel dealer or Customer Support.

**Table 166: OEM7 Receivers**

NovAtel Part	Part Description
OEM719	OEM7 receiver card with OEM6 compatible 20 pin header
OEM729	OEM7 receiver card with OEM6 compatible 24 pin and 16 pin headers
OEM7600	OEM7 receiver card with high density 60 pin socket and small form factor
OEM7700	OEM7 receiver card with high density 60 pin socket
OEM7720	OEM7 receiver card with dual antenna inputs and high density 60 pin socket
PwrPak7	OEM7 enclosure with Wi-Fi and built in data storage
PwrPak7D	Dual antenna OEM7 enclosure with Wi-Fi and built-in data storage
PwrPak7-E1	Single enclosure SPAN GNSS+INS receiver with EG320N IMU, Wi-Fi and built-in data storage
PwrPak7D-E1	Single enclosure SPAN GNSS+INS receiver with dual antenna inputs, EG320N IMU, Wi-Fi and built-in data storage
PwrPak7-E2	Single enclosure SPAN GNSS+INS receiver with EG370N IMU, Wi-Fi and built-in data storage
PwrPak7D-E2	Single enclosure SPAN GNSS+INS receiver with dual antenna inputs, EG370N IMU, Wi-Fi and built-in data storage
PwrPak7M	OEM7 enclosure (no Wi-Fi or data storage)
PwrPak7DM	Dual antenna OEM7 enclosure (no Wi-Fi or data storage)
PwrPak7M-E1	Single enclosure SPAN GNSS+INS receiver with an EG320N IMU (no Wi-Fi or data storage)
PwrPak7DM-E1	Single enclosure SPAN GNSS+INS receiver with dual antenna inputs and EG320N IMU (no Wi-Fi or data storage)
PwrPak7M-E2	Single enclosure SPAN GNSS+INS receiver with an EG370N IMU (no Wi-Fi or data storage)
PwrPak7DM-E2	Single enclosure SPAN GNSS+INS receiver with dual antenna inputs and EG370N IMU (no Wi-Fi or data storage)
PwrPak7Q-E2	Single enclosure SPAN GNSS+INS receiver with EG370N IMU and built-in data storage (no Wi-Fi)
PwrPak7DQ-E2	Single enclosure SPAN GNSS+INS receiver with dual antenna inputs, EG370N IMU and built-in data storage (no Wi-Fi)

**Table 167: SPAN Compatible IMUs**

<b>NovAtel Part</b>	<b>Part Description</b>
IMU-CPT	KVH CPT IMU in an enclosure
IMU-FSAS-EI	IMAR IMU-FSAS IMU
IMU-H1900-CA50	Honeywell HG1900-CA50 IMU in an IMU enclosure
IMU-H1930-CA50	Honeywell HG1930-CA50 IMU
IMU-H58	Honeywell HG1700_AG58 IMU in a SPAN IMU Enclosure
IMU-H62	Honeywell HG1700_AG62 IMU in a SPAN IMU Enclosure
IMU-IGM-A1	Analog Devices ADIS-16488 IMU in an IMU-IGM enclosure
IMU-IGM-S1	Sensoror STIM300 IMU in an IMU-IGM enclosure
IMU-ISA-100C	Litef ISA-100C IMU in an Universal IMU Enclosure
IMU-KVH1750	KVH 1750 IMU
IMU-ENC-LN200	Northrop Grumman LN-200-L IMU in an IMU enclosure
IMU- $\mu$ IMU-IC	Litef $\mu$ IMU-IC IMU in an IMU enclosure
OEM-IMU-ADIS-16488	Analog Devices ADIS16488 IMU
OEM-IMU-EG320N	Epson G320N IMU
OEM-IMU-EG370N	Epson G370N IMU
OEM-IMU-HG1900	Honeywell HG1900-CA50 IMU
OEM-IMU-HG4930-AN01	Honeywell HG4930 AN01 IMU
OEM-IMU-ISA-100C	Litef ISA-100C IMU
OEM-IMU-LN200	Northrop Grumman LN-200-L IMU
OEM-IMU-STIM300	Sensoror STIM300 IMU
OEM-IMU- $\mu$ IMU	Litef $\mu$ IMU-IC IMU
UIMU-H58	Honeywell HG1700_AG58 IMU in a Universal IMU Enclosure
UIMU-H62	Honeywell HG1700_AG62 IMU in a Universal IMU Enclosure
UIMU-LN200	Northrop Grumman LN-200-L IMU in a Universal IMU enclosure
<b>IMU Interface Cards</b>	
OEM-IMU-ADIS-MIC OEM-IMU-STIM-MIC	MEMS Interface Card (MIC) for MEMS IMUs
OEM-IMU-ISA-UIC	Universal IMU Controller (UIC) for OEM-IMU-ISA-100C

**Table 168: GNSS Antennas**

NovAtel Part	Part Description
<b>High Performance Antennas</b>	
GNSS-501	GPS L1, GLONASS L1, BeiDou B1, Galileo E1 and L-Band
GNSS 502	GPS L1/L2, GLONASS L1/L2, BeiDou B1/B2b, Galileo E1/E5b and L-Band
GNSS-802	GPS L1/L2, GLONASS L1/L2, BeiDou B1 and Galileo E1
GNSS-802L	GPS L1/L2, GLONASS L1/L2, BeiDou B1, Galileo E1 and L-Band
GNSS-804	GPS L1/L2, GLONASS L1/L2, BeiDou B1/B2b and Galileo E1/E5b
GNSS-804L	GPS L1/L2, GLONASS L1/L2, BeiDou B1/B2b, Galileo E1/E5b and L-Band
GNSS-850	GPS L1/L2/L5, GLONASS L1/L2/L3, BeiDou B1/B2a/B2b/B3, Galileo E1/E5a/E5b/E6 and L-Band
<b>Compact Antennas</b>	
2G15A-XTB-1	2.6" circular form factor (GPS L1)
3G15A-XT-1	3.5" circular form factor (GPS L1)
42G1215A-XT-1	ARINC-743 bolt pattern (GPS L1/L2)
G5Ant-42AT1	ARINC-743 bolt pattern (GPS L1/L2, GLONASS L1/L2 and L-Band)
3GNSSA-XT-1	3.5" circular form factor (GPS L1/L2/L5, GLONASS L1/L2, BeiDou B1/B2a/B2b/B3, Galileo E1/E5a/E5b/E6, NavIC L5 and L-Band)
42GNSSA-XT-1	ARINC-743 bolt pattern (GPS L1/L2/L5, GLONASS L1/L2, BeiDou B1/B2a/B2b/B3, Galileo E1/E5a/E5b/E6, NavIC L5 and L-Band)
5BE-225-500-XT-1	Blade form factor (UHF 255 – 500 MHz)
G3Ant-2A196MNS-4	2.7" circular form factor (GPS L1, GLONASS L1, L-Band)
G3Ant-42A4T1	ARINC-743 bolt pattern (GPS L1, GLONASS L1, L-Band)

**Table 169: IMU Interface Cables**

NovAtel Part	Part Description
01018388	iIMU-FSAS IMU with Wheel Sensor Interface cable

NovAtel Part	Part Description
01018966	IMU-CPT IMU interface cable
01018977	Universal IMU Enclosure Interface cable
01019007	ADIS IMU Cable Kit
01019013	IMU-IGM Stack Up Cable
01019015	SPAN-IGM Auxiliary Port Interface Cable
01019016	IMU-IGM Interface Cable
01019040	SPAN-IGM/IMU-IGM Bracket Kit
01019174	OEM-IMU-STIM300 Cable
01019211	IMU-KVH1750 Interface Cable
01019319	IMU Enclosure Interface Cable
01019393	UIC to ISA-100C Interface Cable
01019760	UIC to $\mu$ IMU Interface Cable
01019762	UIC to HG1900 Interface Cable
01019763	UIC to LN200 Interface Cable
60723136	IMU Enclosure Power Cable
60723137	IMU Enclosure Wheel Data Cable

**Table 170: GNSS Antenna Cables**

NovAtel Part	Part Description
GPS-C006	5 meters – TNC to TNC cable
GPS-C016	15 meters – TNC to TNC cable
GPS-C032	30 meters – TNC to TNC cable
60723177	2.5 meters – SMA to TNC cable
60723178	5 meters – SMA to TNC cable



