



HEXAGON



**OEM7 SPAN
Installation and Operation
User Manual**

OEM7 SPAN Installation and Operation User Manual

Publication Number: D100405

Revision Level: v3

Revision Date: January 2026

Firmware Version: 7.10.00 / OM7MR1000RN0000

Warranty

NovAtel Inc. warrants that its GNSS products are free from defects in materials and workmanship, subject to the conditions set forth on our web site: novatel.com/products/novatel-warranty-and-return-policies.

Return instructions

To return products, refer to the instructions found at: novatel.com/products/novatel-warranty-and-return-policies.

Proprietary notice

This document and the information contained herein are the exclusive properties of the legal entities that comprise the Autonomous Solutions division of the Hexagon AB group of companies (“Hexagon”).

No part of this document may be reproduced, displayed, distributed, or used in any medium, in connection with any other materials, or for any purpose without prior written permission from Hexagon. Applications for permission may be directed to contact.ap@hexagon.com. Unauthorized reproduction, display, distribution or use may result in civil as well as criminal sanctions under the applicable laws. Hexagon aggressively protects and enforces its intellectual property rights to the fullest extent allowed by law.

This document and the information contained herein are provided AS IS and without any representation or warranty of any kind. Hexagon disclaims all warranties, express or implied, including but not limited to any warranties of merchantability, non-infringement, and fitness for a particular purpose. Nothing herein constitutes a binding obligation on Hexagon.

The information contained herein is subject to change without notice.

ALIGN, GLIDE, Inertial Explorer, NovAtel, OEM6, OEM7, PwrPak7, SPAN, TerraStar and Waypoint are trademarks of Hexagon AB and/or its subsidiaries and affiliates, and/or their licensors. All other trademarks are properties of their respective owners.

© Copyright 2017 – 2026 Hexagon AB and/or its subsidiaries and affiliates. All rights reserved.

Table of contents

Figures

Tables

Receiver card notices

Customer Support

Chapter 1 OEM7 SPAN overview

1.1	Fundamentals of GNSS+INS	27
1.2	SPAN models and features	28
1.2.1	INS options	28
1.2.2	IMU grade	29
1.3	Related documents and information	30

Chapter 2 SPAN installation

2.1	OEM7 receiver card installation	33
2.2	PwrPak7 installation	35
2.3	Mount the IMU	36
2.3.1	Securing the IMU Enclosure	37
2.3.2	Secure an IMU enclosure using the mounting plate	37
2.4	Connect the IMU to the OEM7 receiver card	38
2.4.1	Connect an IMU enclosure to an OEM7 receiver card using a serial port	40
2.4.2	Connect an OEM IMU to an OEM7 receiver card using a UIC	41
2.4.3	Connect an OEM IMU to an OEM7 receiver card using a MIC	41
2.4.4	Connect an OEM IMU to an OEM7 receiver card using a direct connection	41
2.4.5	Connect an OEM-IMU-ADIS-16488 directly to an OEM7 receiver card	41
2.4.6	Connect an OEM-IMU-EG320N or OEM-IMU-EG370N directly to an OEM7 receiver card	43
2.4.7	Connect an OEM-IMU-STIM300 directly to an OEM7 receiver	45
2.4.8	Connect an OEM-IMU-HG4930 directly to an OEM7 receiver	48
2.4.9	Connect an OEM-IMU- μ IMU-IC-UART directly to an OEM7 receiver	52
2.4.10	IMU-KVH1750 and IMU-P1750 baud rate conversion	56
2.5	Connect the IMU to the PwrPak7	57
2.5.1	NovAtel IMU interface cables	57
2.5.2	PwrPak7 cables	57
2.5.3	Custom IMU interface cable requirements	58
2.5.4	Connect an OEM IMU to a PwrPak7 using a direct connection	58
2.6	Connect power	58
2.6.1	Receiver power	59
2.6.2	IMU power	59
2.7	MIC installation	61
2.7.1	Install a MIC in a stack up configuration	61
2.7.2	Install a MIC in a standalone configuration	64
2.7.3	Connect the IMU to the MIC	67
2.7.4	Connect power to the MIC and OEM7 receiver	69
2.7.5	Connect the input and output signals	70

2.8	UIC installation	71
2.8.1	Mount the SPAN system components	72
2.8.2	Connect the IMU to the UIC	73
2.8.3	Connect the UIC to a receiver	73
2.8.4	Connect power to the UIC and OEM7 receiver	74
2.8.5	UIC Status LEDs	74
2.9	IMU LEDs	75

Chapter 3 SPAN operation

3.1	Definition of reference frames within SPAN	76
3.1.1	Local-level frame (ENU)	76
3.1.2	IMU body frame	77
3.1.3	Vehicle frame	77
3.1.4	User output frame	78
3.2	SPAN translations and rotations	78
3.2.1	Translational offsets	78
3.2.2	Rotational offsets	80
3.2.3	Output location for logs	81
3.3	Vibration considerations	83
3.3.1	Sources of error	84
3.3.2	Mitigation methods	84
3.3.3	Additional notes	84
3.4	Software configuration	85
3.4.1	GNSS configuration	85
3.4.2	INS Profiles	85
3.4.3	SPAN configuration	87
3.4.4	SPAN configuration for PwrPak7	92
3.4.5	Importance of lever arms	96
3.4.6	Importance of RBV calibration	98
3.4.7	Importance of antenna location for ALIGN	99
3.5	Real-time operation	100
3.5.1	System start-up and alignment techniques	101
3.5.2	INS Seed / Fast INS initialization	105
3.5.3	Navigation mode	107
3.5.4	Data collection	107
3.5.5	Recommended messages to be logged for SPAN data collection	109
3.5.6	Lever arm calibration routine	110
3.5.7	Body to vehicle frame rotation calibration routine	111
3.5.8	Multi-line body to vehicle frame rotation calibration routine	112
3.6	Synchronizing external equipment	114
3.6.1	Configuring an input strobe	114
3.7	Adding timed sensor triggers	115
3.7.1	Configuring the hardware	115
3.7.2	Configuring the software	116
3.7.3	Using timed event pulses	116
3.7.4	Recording incoming sensor events	116
3.8	Distance Measurement Instrument	116
3.8.1	DMI communication	117

3.8.2	DMI connection	118
3.8.3	DMI requirements	118
3.8.4	DMI connected to a PwrPak7	120
3.8.5	DMI connected to an IMU	122
3.8.6	DMI connected to a UIC	124
3.8.7	DMI connected to an intermediate processor	126
3.8.8	DMI command compatibility	129
3.8.9	DMI troubleshooting	129
3.9	Azimuth sources on a SPAN system	130
3.9.1	Course over ground	130
3.9.2	Inertial azimuth	130
3.9.3	ALIGN azimuth	130
3.10	Data collection for post processing	131
3.11	Firmware updates and model upgrades	133
3.12	Variable Lever Arm	133
3.12.1	Reference frame description	133
3.12.2	Example gimbal installation	134
3.12.3	How to use Variable Lever Arm	135
3.13	Relative INS	137
3.13.1	Configure Relative INS	138

Chapter 4 SPAN with dual antenna

4.1	Installation	139
4.2	Configuring dual antenna ALIGN with SPAN	141
4.2.1	Setup and configuration	141
4.2.2	Optional HEADINGOFFSET configuration	142

Appendix A IMU technical specifications

A.1	HG1700 IMU (single-connector enclosure)	145
A.1.1	HG1700 IMU mechanical drawings	146
A.1.2	HG1700 IMU performance	148
A.1.3	HG1700 electrical and environmental	149
A.1.4	Interface cable for the HG1700 IMU	149
A.2	LN-200 IMU (single-connector enclosure)	150
A.2.1	LN-200 IMU mechanical drawings	151
A.2.2	LN-200 IMU performance	153
A.2.3	LN-200 electrical and environmental	153
A.2.4	Interface cable for the LN-200 IMU	153
A.3	Universal IMU Enclosure (HG1700, LN200)	154
A.3.1	Universal IMU Enclosure mechanical drawings	155
A.3.2	IMU performance	159
A.3.3	Electrical and environmental	161
A.3.4	Universal IMU Enclosure interface cable	162
A.4	IMU-CPT	164
A.4.1	IMU-CPT mechanical drawings	165
A.4.2	IMU-CPT sensor specifications	167
A.4.3	IMU-CPT electrical and environmental	168
A.4.4	IMU-CPT cable	169

A.5	IMU-FSAS	171
A.5.1	IMU-FSAS mechanical drawings	172
A.5.2	IMU-FSAS performance	174
A.5.3	IMU-FSAS electrical and environmental	174
A.5.4	Interface cable for IMU-FSAS	175
A.5.5	IMU-FSAS cable with wheel sensor	175
A.6	IMU-HG1900	178
A.6.1	IMU-HG1900 mechanical drawings	179
A.6.2	IMU-HG1900 sensor specifications	181
A.6.3	IMU-HG1900 electrical and environmental	182
A.6.4	IMU-HG1900 cables	182
A.7	IMU-IGM-A1 and IMU-IGM-S1	183
A.7.1	IMU-IGM-A1 and IMU-IGM-S1 mechanical drawings	184
A.7.2	IMU-IGM-A1 and IMU-IGM-S1 ports	186
A.7.3	IMU-IGM-A1 and IMU-IGM-S1 sensor specifications	188
A.7.4	IMU-IGM-A1 and IMU-IGM-S1 electrical and environmental	189
A.7.5	IMU-IGM interface cable	190
A.8	IMU-ISA-100C	192
A.8.1	IMU-ISA-100C mechanical drawings	193
A.8.2	Optional side mounting holes	195
A.8.3	IMU-ISA-100C sensor specifications	197
A.8.4	IMU-ISA-100C electrical and environmental	198
A.8.5	IMU Enclosure interface cable	199
A.8.6	IMU Enclosure power cable	201
A.8.7	IMU Enclosure wheel sensor cable	202
A.9	IMU-KVH1750	204
A.9.1	IMU-KVH1750 mechanical drawings	205
A.9.2	IMU-KVH1750 sensor specifications	210
A.9.3	IMU-KVH1750 electrical and environmental	211
A.9.4	IMU-KVH1750 and IMU-P1750 cable	212
A.10	IMU-P1750	214
A.10.1	IMU-P1750 mechanical drawings	215
A.10.2	IMU-P1750 sensor specifications	220
A.10.3	IMU-P1750 electrical environmental	221
A.11	IMU-LN200	222
A.11.1	IMU-LN200 mechanical drawings	223
A.11.2	IMU-LN200 sensor specifications	225
A.11.3	IMU-LN200 electrical and environmental	226
A.11.4	IMU-LN200 cables	226
A.12	IMU- μ IMU-IC	227
A.12.1	IMU- μ IMU-IC mechanical drawings	228
A.12.2	IMU- μ IMU-IC sensor specifications	230
A.12.3	IMU- μ IMU-IC electrical and environmental	231
A.12.4	IMU- μ IMU-IC cables	231
A.13	OEM-IMU-ADIS-16488	232
A.13.1	OEM-IMU-ADIS-16488 mechanical drawings	233
A.13.2	OEM-IMU-ADIS-16488 sensor specifications	236
A.13.3	OEM-IMU-ADIS-16488 electrical and environmental	236

A.13.4	OEM-IMU-ADIS-16488 SPI connection	237
A.13.5	OEM-IMU-ADIS-16488 IMU-to-MIC cable assembly	238
A.14	OEM-IMU-EG320N	239
A.14.1	OEM-IMU-EG320N mechanical drawings	240
A.14.2	OEM-IMU-EG320N sensor specifications	241
A.14.3	OEM-IMU-EG320N electrical and environmental	242
A.14.4	OEM-IMU-EG320N interface connector	243
A.15	OEM-IMU-EG370N	245
A.15.1	OEM-IMU-EG370N mechanical drawings	246
A.15.2	OEM-IMU-EG370N sensor specifications	247
A.15.3	OEM-IMU-EG370N electrical and environmental	247
A.15.4	OEM-IMU-EG370N interface connector	248
A.16	OEM-IMU-HG4930	250
A.16.1	OEM-IMU-HG4930 mechanical drawings	251
A.16.2	OEM-IMU-HG4930 sensor specifications	252
A.16.3	OEM-IMU-HG4930 electrical and environmental	252
A.16.4	OEM-IMU-HG4930 interface connector	253
A.17	OEM-IMU-ISA-100C	254
A.17.1	OEM-IMU-ISA-100C mechanical drawings	255
A.17.2	OEM-IMU-ISA-100C sensor specifications	258
A.17.3	OEM-IMU-ISA-100C electrical and environmental	258
A.17.4	OEM-IMU-ISA-100C IMU to UIC cable assembly	259
A.18	OEM-IMU-STIM300	262
A.18.1	OEM-IMU-STIM300 mechanical drawings	263
A.18.2	OEM-IMU-STIM300 sensor specifications	264
A.18.3	OEM-IMU-STIM300 electrical and environmental	264
A.18.4	OEM-IMU-STIM300 direct connection	265
A.18.5	OEM-IMU-STIM300 IMU-to-MIC cable assembly	268
A.19	OEM-IMU- μ IMU-IC / OEM-IMU- μ IMU-IC-UART	269
A.19.1	OEM-IMU- μ IMU-IC / OEM-IMU- μ IMU-IC-UART comparison	269
A.19.2	OEM-IMU- μ IMU-IC / OEM-IMU- μ IMU-IC-UART mechanical drawings	271
A.19.3	OEM-IMU- μ IMU-IC / OEM-IMU- μ IMU-IC-UART sensor specifications	273
A.19.4	OEM-IMU- μ IMU-IC / OEM-IMU- μ IMU-IC-UART electrical and environmental	274
A.19.5	OEM-IMU- μ IMU-IC to UIC cable assembly	275
A.20	MIC – MEMS Interface Card	277
A.20.1	MIC mechanical drawings	278
A.20.2	MIC electrical and environmental	280
A.20.3	MIC connectors	281
A.20.4	OEM-HG1930 IMU-to-MIC cable assembly	286
A.20.5	HG1700 and OEM-HG1900 IMU-to-MIC cable assembly	288
A.21	UIC – Universal IMU Controller	290
A.21.1	UIC mechanical drawings	291
A.21.2	UIC electrical and environmental	294
A.21.3	UIC connectors	295
A.21.4	OEM-HG1900 IMU to UIC cable assembly	299
A.21.5	LN200 IMU to UIC cable assembly	300

Appendix B HG1700 IMU in Universal Enclosure

B.1 Disassemble the Universal enclosure	302
B.2 Install the HG1700 sensor unit	304

Appendix C LN-200 IMU in Universal enclosure

C.1 Disassemble the Universal enclosure	311
C.2 Install the LN-200 sensor unit	313

Appendix D HG1700 IMU in SPAN HG enclosure

D.1 Disassemble the SPAN IMU enclosure	318
D.2 Install the HG1700 sensor unit	320
D.3 Make the electrical connections	321
D.4 Re-Assemble the SPAN IMU enclosure	323

Appendix E LN-200 IMU in SPAN IMU enclosure

E.1 Disassemble the SPAN IMU enclosure	324
E.2 Install the LN-200 sensor unit	326
E.3 Make the electrical connections	327
E.4 Re-Assemble the SPAN IMU enclosure	329

Appendix F Frequently asked questions

Appendix G Importance of antenna selection

Appendix H Accessories and replacement parts

Figures

Figure 1: Typical installation of a SPAN system with an OEM7 receiver card	33
Figure 2: Typical installation of a SPAN system with a PwrPak7	35
Figure 3: IMU enclosure mounting plate	38
Figure 4: OEM-IMU-ADIS-16488 pin locations	42
Figure 5: OEM-IMU-EG320N/OEM-IMU-EG370N pin locations	44
Figure 6: OEM-IMU-STIM300 pinout	46
Figure 7: OEM-IMU- μ IMU-IC-UART pinout	53
Figure 8: Basic set up – MIC in stack up configuration	62
Figure 9: Mount the MIC on the OEM719	64
Figure 10: Basic MIC set up	65
Figure 11: Connect the OEM-HG1900 IMU to the MIC (OEM Cable Kit: 01018871)	68
Figure 12: Connect the OEM-HG1930 IMU to the MIC (OEM Cable Kit: 01018869)	68
Figure 13: Connect the OEM-IMU-ADIS-16488 IMU to the MIC (OEM Cable Kit: 01019007)	69
Figure 14: Connect the OEM-IMU-STIM300 IMU to the MIC (OEM Cable Kit: 01019174)	69
Figure 15: Basic UIC installation	71
Figure 16: UIC Status LEDs	74
Figure 17: Local-level frame (ENU)	77
Figure 18: IMU body frame marking	77
Figure 19: Vehicle frame	78
Figure 20: IMU to antenna translation offset	79
Figure 21: Antenna lever arm – total station	97
Figure 22: Antenna lever arm – tape measure	98
Figure 23: Rear view of PwrPak7-E1 – mounting plate is not flat	98
Figure 24: Side view of PwrPak7-E1 – vehicle is not level	99
Figure 25: Top view of PwrPak7-E1 – PwrPak7-E1 misalignment	99
Figure 26: Multi-line IMU body to vehicle calibration	113
Figure 27: Wheel sensor pulses (dual channel, quadrature, RS-422 differential)	117
Figure 28: Kistler WPT	119
Figure 29: DMI to PwrPak7 setup	121
Figure 30: DMI to IMU setup	123
Figure 31: DMI to UIC setup	125
Figure 32: DMI through intermediate processor setup	126
Figure 33: Sample configuration	134
Figure 34: Operating gimbal	135

Figure 35: Relative INS example	137
Figure 36: SPAN – two receiver dual antenna installation	140
Figure 37: SPAN – single receiver dual antenna installation	141
Figure 38: HG1700 top/bottom dimensions	146
Figure 39: HG1700 enclosure side dimensions	147
Figure 40: LN-200 IMU Enclosure top/bottom dimensions and centre of navigation	151
Figure 41: LN-200 Enclosure side dimensions	152
Figure 42: Universal IMU Enclosure side dimensions	155
Figure 43: Universal IMU Enclosure top/bottom dimensions	156
Figure 44: Universal IMU Enclosure centre of navigation	157
Figure 45: Universal IMU Enclosure frame axis	158
Figure 46: Universal IMU Enclosure interface cable	162
Figure 47: IMU-CPT side and perspective view	165
Figure 48: IMU-CPT top, front and bottom view	166
Figure 49: IMU-CPT development terminated cable	169
Figure 50: IMU-FSAS top dimensions	172
Figure 51: IMU-FSAS bottom dimensions	172
Figure 52: IMU-FSAS side dimensions	173
Figure 53: IMU-FSAS centre of navigation	173
Figure 54: IMU-FSAS interface cable with wheel sensor	175
Figure 55: IMU-HG1900 dimensions	179
Figure 56: IMU-HG1900 centre of navigation	180
Figure 57: IMU-IGM-A1 dimensions	184
Figure 58: IMU-IGM-S1 dimensions	185
Figure 59: IMU-IGM interface cable	190
Figure 60: IMU-ISA-100C dimensions	193
Figure 61: IMU-ISA-100C centre of navigation	194
Figure 62: Optional side mounting holes	196
Figure 63: IMU Enclosure interface cable	199
Figure 64: IMU Enclosure power cable	201
Figure 65: IMU Enclosure wheel sensor cable	202
Figure 66: IMU-KVH1750 bottom view	205
Figure 67: IMU-KVH1750 top view	206
Figure 68: IMU-KVH1750 side view	207
Figure 69: IMU-KVH1750 gyro axes	208
Figure 70: IMU-KVH1750 and IMU-P1750 cable	212
Figure 71: IMU-P1750 bottom view	215

Figure 72: IMU-P1750 top view	216
Figure 73: IMU-P1750 side view	217
Figure 74: IMU-P1750 gyro axes	218
Figure 75: IMU-LN200 dimensions	223
Figure 76: IMU-LN200 centre of navigation	224
Figure 77: IMU- μ IMU-IC dimensions	228
Figure 78: IMU- μ IMU-IC centre of navigation	229
Figure 79: OEM-IMU-ADIS-16488 dimensions – with interface board	233
Figure 80: OEM-IMU-ADIS-16488 centre of navigation	234
Figure 81: OEM-IMU-ADIS-16488 dimensions	235
Figure 82: OEM-IMU-ADIS-16488 IMU-to-MIC cable assembly	238
Figure 83: EG320N dimensions	240
Figure 84: OEM-IMU-EG320N pin locations	243
Figure 85: EG370N dimensions	246
Figure 86: OEM-IMU-EG370N pin locations	248
Figure 87: OEM-IMU-HG4930 centre of navigation	251
Figure 88: OEM-IMU-ISA-100C centre of gravity	255
Figure 89: OEM-IMU-ISA-100C centre of accelerometers	256
Figure 90: OEM-IMU-ISA-100C coordinate axis	257
Figure 91: OEM-IMU-ISA-100C IMU to UIC cable assembly	259
Figure 92: OEM-IMU-STIM300 dimensions	263
Figure 93: OEM-IMU-STIM300 centre of navigation	263
Figure 94: OEM-IMU-STIM300 IMU-to-MIC cable assembly	268
Figure 95: OEM-IMU- μ IMU-IC / OEM-IMU- μ IMU-IC-UART top dimensions	271
Figure 96: OEM-IMU- μ IMU-IC / OEM-IMU- μ IMU-IC-UART side dimensions	271
Figure 97: OEM-IMU- μ IMU-IC / OEM-IMU- μ IMU-IC-UART bottom dimensions	272
Figure 98: OEM-IMU- μ IMU-IC / OEM-IMU- μ IMU-IC-UART coordinate axis	272
Figure 99: OEM-IMU- μ IMU-IC to UIC cable assembly	275
Figure 100: MIC dimensions	278
Figure 101: MIC keep-out zone	279
Figure 102: OEM-HG1930 IMU-to-MIC cable assembly	286
Figure 103: HG1700 and OEM-HG1900 IMU-to-MIC cable assembly	288
Figure 104: UIC dimensions and keep out zones	292
Figure 105: UIC connectors, LEDs and heat sink details	293
Figure 106: OEM-HG1900 IMU to UIC cable assembly	299
Figure 107: OEM-IMU-LN200 IMU to UIC cable assembly	300
Figure 108: Required parts	302

Figure 109: Remove base	303
Figure 110: Disconnect wiring harness from enclosure body	303
Figure 111: Remove IMU mounting plate and bracket	304
Figure 112: Remove IMU mounting screws	305
Figure 113: Connect IMU to IMU mounting plate	305
Figure 114: Installing IMU to mounting plate	306
Figure 115: Assemble Into enclosure body	307
Figure 116: Fasten internal cable harness	308
Figure 117: Install O-rings	308
Figure 118: Install enclosure body on the base	309
Figure 119: Screw enclosure base to body	309
Figure 120: Final assembly	310
Figure 121: Required parts	311
Figure 122: Remove base	312
Figure 123: Disconnect wiring harness from SDLC card	312
Figure 124: IMU bracket	313
Figure 125: Remove IMU bracket/SDLC	313
Figure 126: Install LN-200 IMU to base	314
Figure 127: Install bracket to base	314
Figure 128: Making connections	315
Figure 129: Connect internal cable harness	315
Figure 130: Installing the enclosure body to the base	316
Figure 131: Screw enclosure base to body	316
Figure 132: Final assembly	317
Figure 133: Required parts	318
Figure 134: Bolts and hex key	319
Figure 135: Lift top cover, tube body and 3 ring spacer screws	320
Figure 136: SPAN IMU re-assembly	321
Figure 137: Attach flex cable	322
Figure 138: Incorrect (bowed) flex cable installation	323
Figure 139: Correct (flat) flex cable installation	323
Figure 140: HG1700 SPAN IMU	323
Figure 141: Required parts	324
Figure 142: Bolts and hex key	325
Figure 143: Lift top cover and tube body	326
Figure 144: SPAN IMU re-assembly	327
Figure 145: Attach wiring harness	328

Figure 146: Attach Samtec connector	329
Figure 147: LN-200 SPAN IMU	330
Figure 148: Plot of good and poor antenna phase centre variation over elevation angle 0-90°	334

Tables

Table 1: INS options (previous to OEM 7.08)	29
Table 2: INS options (OEM 7.08 and later)	29
Table 3: SPAN-compatible IMUs	30
Table 4: IMU connection method	39
Table 5: Receiver to OEM-IMU-ADIS-16488 pin connections	42
Table 6: Receiver to OEM-IMU-EG320N/OEM-IMU-EG370N pin connections	44
Table 7: OEM7 receiver card to OEM-IMU-STIM300 pin connections	46
Table 8: OEM729 COM1 or PwrPak7 to OEM-IMU-STIM300 pin connections	47
Table 9: OEM-IMU-HG4930 mating connector	49
Table 10: OEM7 receiver card to OEM-IMU-HG4930 pin connections	50
Table 11: COM1 on the OEM729 to OEM-IMU-HG4930 pin connections	51
Table 12: PwrPak7 to OEM-IMU-HG4930 pin connections	52
Table 13: OEM7 receiver card to OEM-IMU- μ IMU-IC-UART pin connections	53
Table 14: OEM729 COM1 or PwrPak7 to OEM-IMU- μ IMU-IC-UART pin connections	54
Table 15: Additional IMU to PwrPak7 connections	58
Table 16: IMU power supply	59
Table 17: COM port recommendations	67
Table 18: COM port recommendations	73
Table 19: UIC Status LEDs	75
Table 20: IMU-IGM-A1 and IMU-IGM-S1 LEDs	75
Table 21: IMU Enclosure LEDs	75
Table 22: Output location and frame for logs	81
Table 23: OEM7 INS Profiles	85
Table 24: Enable INS commands	88
Table 25: Enable INS commands	93
Table 26: Inertial solution status	101
Table 27: NVM seed indication	107
Table 28: Solution parameters	107
Table 29: Valid event inputs and outputs for timed sensor triggers	116
Table 30: Wheel sensor maximum pulse rates	119
Table 31: Kistler to NovAtel wheel sensor cable connections	120
Table 32: DMI command and log compatibility	129
Table 33: Logs with azimuth data	131
Table 34: Logs used with Variable Lever Arm	135

Table 35: Commands used with Variable Lever Arm	136
Table 36: HG1700 IMU physical specifications	145
Table 37: HG1700-AG58 IMU performance	148
Table 38: HG1700-AG62 IMU performance	148
Table 39: HG1700 electrical specifications	149
Table 40: HG1700 environmental specifications	149
Table 41: LN-200 IMU physical specifications	150
Table 42: LN-200 IMU performance	153
Table 43: LN-200 electrical specifications	153
Table 44: LN-200 environmental specifications	153
Table 45: Universal IMU Enclosure physical specifications	154
Table 46: HG1700-AG58 IMU performance	159
Table 47: HG1700-AG62 IMU performance	159
Table 48: LN-200 IMU performance	160
Table 49: Universal IMU Enclosure electrical specifications	161
Table 50: Universal IMU Enclosure environmental specifications	161
Table 51: Universal IMU Enclosure Interface cable pinout	162
Table 52: Connectors	163
Table 53: Maximum cable length	163
Table 54: IMU-CPT physical specifications	164
Table 55: IMU-CPT performance	167
Table 56: IMU-CPT electrical specifications	168
Table 57: IMU-CPT environmental specifications	168
Table 58: IMU-CPT connector pinout descriptions	169
Table 59: Connectors	170
Table 60: Maximum cable length	170
Table 61: IMU-FSAS physical specifications	171
Table 62: IMU-FSAS performance	174
Table 63: IMU-FSAS electrical specifications	174
Table 64: IMU-FSAS environmental specifications	174
Table 65: IMU-FSAS cable with wheel sensor pinout	176
Table 66: Connectors	177
Table 67: Maximum cable length	177
Table 68: IMU-HG1900 physical specifications	178
Table 69: IMU-HG1900 IMU performance	181
Table 70: IMU-HG1900 electrical specifications	182
Table 71: IMU-HG1900 environmental specifications	182

Table 72: IMU-IGM-A1 physical specifications	183
Table 73: IMU-IGM-S1 physical specifications	183
Table 74: IMU-IGM-A1 and IMU-IGM-S1 Main port pinout	186
Table 75: IMU-IGM-A1 and IMU-IGM-S1 AUX port pinout	186
Table 76: IMU-IGM-A1 IMU performance	188
Table 77: IMU-IGM-S1 IMU performance	188
Table 78: IMU-IGM-A1 electrical specifications	189
Table 79: IMU-IGM-A1 environmental specifications	189
Table 80: IMU-IGM-S1 electrical specifications	189
Table 81: IMU-IGM-S1 environmental specifications	189
Table 82: IMU-IGM interface cable pinout descriptions	190
Table 83: Connectors	191
Table 84: Maximum cable length	191
Table 85: IMU-ISA-100C physical specifications	192
Table 86: IMU-ISA-100C IMU performance	197
Table 87: IMU-ISA-100C electrical specifications	198
Table 88: IMU-ISA-100C environmental specifications	198
Table 89: IMU Enclosure interface cable pinout	199
Table 90: Connectors	200
Table 91: Maximum cable length	200
Table 92: IMU Enclosure power cable pinout	201
Table 93: IMU Enclosure wheel sensor cable pinout	202
Table 94: Connectors	203
Table 95: Maximum cable length	203
Table 96: IMU-KVH1750 physical specifications	204
Table 97: IMU-KVH1750 performance	210
Table 98: IMU-KVH1750 electrical specifications	211
Table 99: IMU-KVH1750 environmental specifications	211
Table 100: IMU-KVH1750 and IMU-P1750 connector pinout descriptions	212
Table 101: Connectors	213
Table 102: Maximum cable length	213
Table 103: IMU-P1750 physical specifications	214
Table 104: IMU-P1750 performance	220
Table 105: IMU-P1750 electrical specifications	221
Table 106: IMU-P1750 environmental specifications	221
Table 107: IMU-LN200 physical specifications	222
Table 108: LN-200 IMU performance	225

Table 109: IMU-LN200C IMU performance	225
Table 110: IMU-LN200 electrical specifications	226
Table 111: IMU-LN200 environmental specifications	226
Table 112: IMU- μ IMU-IC physical specifications	227
Table 113: IMU- μ IMU-IC IMU performance	230
Table 114: IMU- μ IMU-IC electrical specifications	231
Table 115: IMU- μ IMU-IC environmental specifications	231
Table 116: OEM-IMU-ADIS-16488 physical specifications	232
Table 117: OEM-IMU-ADIS-16488 performance	236
Table 118: OEM-IMU-ADIS-16488 electrical specifications	236
Table 119: OEM-IMU-ADIS-16488 environmental specifications	236
Table 120: Receiver to OEM-IMU-ADIS-16488 pin connections	237
Table 121: OEM-IMU-ADIS-16488 IMU-to-MIC cable pinout	238
Table 122: OEM-IMU-EG320N physical specifications	239
Table 123: OEM-IMU-EG320N performance	241
Table 124: OEM-IMU-EG320N electrical specifications	242
Table 125: OEM-IMU-EG320N environmental specifications	242
Table 126: OEM-IMU-EG320N connector	243
Table 127: OEM-IMU-EG370N physical specifications	245
Table 128: OEM-IMU-EG370N performance	247
Table 129: OEM-IMU-EG370N electrical specifications	247
Table 130: OEM-IMU-EG370N environmental specifications	247
Table 131: OEM-IMU-EG370N connector	248
Table 132: OEM-IMU-HG4930 physical specifications	250
Table 133: OEM-IMU-HG4930 performance	252
Table 134: OEM-IMU-HG4930 electrical specifications	252
Table 135: OEM-IMU-HG4930 environmental specifications	252
Table 136: OEM-IMU-HG4930 connector	253
Table 137: OEM-IMU-ISA-100C physical specifications	254
Table 138: OEM-IMU-ISA-100C IMU performance	258
Table 139: OEM-IMU-ISA-100C electrical specifications	258
Table 140: OEM-IMU-ISA-100C environmental specifications	258
Table 141: OEM-IMU-ISA-100C IMU to UIC cable pinout	259
Table 142: OEM-IMU-STIM300 physical specifications	262
Table 143: OEM-IMU-STIM300 performance	264
Table 144: OEM-IMU-STIM300 electrical specifications	264
Table 145: OEM-IMU-STIM300 environmental specifications	264

Table 146: OEM7 receiver card to OEM-IMU-STIM300 pin connections	265
Table 147: OEM729 COM1 or PwrPak7 to OEM-IMU-STIM300 pin connections	266
Table 148: OEM-IMU-STIM300 IMU-to-MIC cable pinout	268
Table 149: OEM-IMU- μ IMU-IC / OEM-IMU- μ IMU-IC-UART physical specifications	269
Table 150: OEM-IMU- μ IMU-IC / OEM-IMU- μ IMU-IC-UART performance	273
Table 151: OEM-IMU- μ IMU-IC electrical specifications	274
Table 152: OEM-IMU- μ IMU-IC-UART electrical specifications	274
Table 153: OEM-IMU- μ IMU-IC / OEM-IMU- μ IMU-IC-UART environmental specifications	274
Table 154: OEM-IMU- μ IMU-IC to UIC cable pinout	275
Table 155: MIC physical specifications	277
Table 156: MIC electrical specifications	280
Table 157: MIC environmental specifications	280
Table 158: MIC connectors	281
Table 159: Pinout for power connector (P101)	281
Table 160: Pinout for user interface connector (P301)	281
Table 161: Pinout for IMU connector (P601)	283
Table 162: Pinout for IMU connector (P701)	284
Table 163: MIC LED indicator drivers	285
Table 164: OEM-HG1930 IMU-to-MIC cable assembly	286
Table 165: HG1700 and OEM-HG1900 IMU-to-MIC cable assembly	288
Table 166: UIC physical specifications	290
Table 167: UIC electrical specifications	294
Table 168: UIC environmental specifications	294
Table 169: UIC connectors	295
Table 170: Pinout for power connector (J101)	295
Table 171: Pinout for UIC to receiver communications connector (J102)	295
Table 172: Pinout for UIC to IMU communications connector (J1401)	296
Table 173: OEM-HG1900 IMU to UIC cable pinout	299
Table 174: OEM-IMU-LN200 IMU to UIC cable pinout	300
Table 175: OEM7 receivers	336
Table 176: SPAN compatible IMUs	337
Table 177: GNSS antennas	338
Table 178: IMU interface cables	339
Table 179: GNSS antenna cables	339

Receiver card notices

The following notices apply to the OEM7 family products.



Changes or modifications to this equipment, not expressly approved by NovAtel Inc., could void the user's authority to operate this equipment.

FCC

The devices covered by this manual comply with part 15 of the FCC Rules. Operation is subject to the following two conditions: (1) this device may not cause harmful interference, and (2) this device must accept any interference received, including interference that may cause undesired operation.

The equipment listed has been tested and found to comply with the limits for a Class B digital device, pursuant to part 15 of the FCC Rules. The Class B limits are designed to provide reasonable protection against harmful interference in a residential installation. The equipment listed generates, uses, and can radiate radio frequency energy and, if not installed and used in accordance with the instructions, may cause harmful interference to radio communications. However, there is no guarantee that interference will not occur in a particular installation. If this equipment does cause harmful interference to radio or television reception, which can be determined by turning the equipment off and on, the user is encouraged to try to correct the interference by one or more of the following measures:

- Reorient or relocate the receiving antenna
- Increase the separation between the equipment and the receiver
- Connect the equipment to an outlet on a circuit different from that to which the receiver is connected
- Consult the dealer or an experienced radio/TV technician for help

Innovation, Science and Economic Development (ISED) Canada

OEM7 Class B digital device complies with Canadian ICES-003.

OEM7 appareils numérique de la classe B sont conforme à la norme NMB-003 du Canada.

This device complies with ISED license-exempt RSS-GEN and RSS-247. Operation is subject to the following two conditions: (1) this device may not cause interference and (2) this device must accept any interference, including interference that may cause undesired operation of the device.

Cet appareil est conforme à la norme ISED RSS-GEN et RSS-247. Son fonctionnement est soumis aux deux conditions suivantes: (1) cet appareil ne doit pas provoquer d'interférences et (2) cet appareil doit accepter toute interférence, y compris les interférences pouvant entraîner un fonctionnement indésirable de l'appareil.

European Union (EU) / United Kingdom (UK)

NovAtel Inc. declares that the OEM7 GNSS receiver is in compliance with:

1. EU Directive 2014/53/EU
2. UK Regulations S.I. 2017/1206

The full text of the Declaration of Conformity may be obtained from the NovAtel website at:

novatel.com/products/novatel-compliance.

WEEE

If you purchased your OEM7 family product in Europe or the United Kingdom, please return it to your dealer or supplier at the end of life. The objectives NovAtel's environment policy are, in particular, to preserve, protect and improve the quality of the environment, protect human health and utilise natural resources prudently and rationally. Sustainable development advocates the reduction of wasteful consumption of natural resources and the prevention of pollution. Waste Electrical and Electronic Equipment (WEEE) is a regulated area. Where the generation of waste cannot be avoided, it should be reused or recovered for its material or energy. WEEE

products may be recognized by their wheeled bin label ()

See novatel.com/products/novatel-compliance/novatel-environmental-compliance for more information.

RoHS

The OEM7 GNSS receivers are in conformity with:

1. Directive 2011/65/EU of the European Parliament and of the council of 8 June 2011 on the restriction of the use of certain hazardous substances in electrical and electronic equipment.
2. the Restriction of the Use of Certain Hazardous Substances in Electrical and Electronic Equipment (Amendment) Regulations 2012 (S.I. 2012/3032).

Lightning protection

For a permanent or a fixed station installation, NovAtel recommends the installation of a lightning protection device for the GNSS antenna cable and/or radio antenna cable at the building entry point in accordance with the local electrical code.

Equipment protection measures should include:

- Selection of a suitable Lightning/Surge protection device
- Safety/Equipment rack grounding
- Lightning/Surge Protection of power lines and communication ports at the building entry point

For more information regarding the selection of surge protection devices for your application, the following websites are provided as a reference.

www.polyphaser.com/

www.hubersuhner.com



Only qualified personnel, such as electricians mandated by the governing body in the country of installation, may install lightning protection devices.

Conventions

The following conventions are used in this manual:



Information that supplements or clarifies text.



A caution that actions, operation or configuration may lead to incorrect or improper use of the hardware.



A warning that actions, operation or configuration may result in regulatory noncompliance, safety issues or equipment damage.



Identifies content that is specific to receivers using 7.09.xx firmware.



Identifies content that is specific to receivers using 7.10.xx firmware.

Customer Support

NovAtel knowledge base

If you have a technical issue, visit the NovAtel Support page at novatel.com/support. Through the *Support* page you can contact Customer Support, find papers and tutorials or download the latest firmware. To access the latest user documentation, visit docs.novatel.com/OEM7.

Before contacting Customer Support

Before contacting NovAtel Customer Support about a software problem, perform the following steps:



If logging data over an RS-232 serial cable, ensure that the configured baud rate can support the data bandwidth (see **SERIALCONFIG** command). NovAtel recommends a minimum suggested baud rate of 230400 bps.

1. Use the information in the **Troubleshooting** section to diagnose and troubleshoot your receiver's symptoms. Refer to the OEM7 Documentation Portal (docs.novatel.com/OEM7/Content/Troubleshooting/Troubleshooting.htm).
2. Log the data suggested in the appropriate *Troubleshooting Logs* section to a file on your computer for 15 minutes.
 - *General troubleshooting logs* on the next page
 - *Tracking and interference troubleshooting logs* on the next page
 - *SPAN troubleshooting logs* on page 24
 - *RTK troubleshooting logs* on page 24
 - *PPP troubleshooting logs* on page 25
 - *ALIGN troubleshooting logs* on page 26

If using NovAtel Application Suite, log the Troubleshooting message set for 15 minutes.

3. Send the data file to NovAtel Customer Support: support.novatel@hexagon.com
4. You can also issue a **FRESET** command to the receiver to clear any unknown settings.



The **FRESET** command will erase all user settings. You should know your configuration (by requesting the RXCONFIGA log) and be able to reconfigure the receiver before you send the **FRESET** command.

If you are having a hardware problem, send a list of the troubleshooting steps taken and the results.

Contact information

Log a support request with NovAtel Customer Support using one of the following methods:

Log a case and search knowledge:

Website: novatel.com/support

Log a case, search knowledge and view your case history: (login access required)

Web Portal: shop.novatel.com/novatelstore/s/contactsupport

E-mail:

support.novatel@hexagon.com

Telephone:

U.S. and Canada: 1-800-NOVATEL (1-800-668-2835)

International: +1-403-295-4900

General troubleshooting logs

```
LOG RXSTATUSB ONCHANGED
LOG RAWEPHEMB ONNEW
LOG GLORAWEPHEMB ONNEW
LOG BESTPOSB ONTIME 1
LOG RANGE B ONTIME 0.5
LOG RXCONFIGA ONCE
LOG VERSIONA ONCE
LOG LOGLISTA ONCE
LOG PORTSTATSA ONTIME 10
LOG PROFILEINFOA ONCE
LOG HWMONITORA ONTIME 10
```

Tracking and interference troubleshooting logs

```
LOG VERSIONA ONCE
LOG RXCONFIGA ONCE
LOG CHANCONFIGLISTB ONCE
LOG PASSTHROUGHHA ONNEW
LOG RXSTATUSB ONCHANGED
LOG CLOCKSTEERINGB ONCHANGED
LOG RAWEPHEMB ONNEW
LOG GLORAWEPHEMB ONNEW
LOG GALINAVRAWEPHEMERISB ONNEW
LOG BDSEPEHEMERISB ONNEW
LOG QZSSEPEHEMERISB ONNEW
LOG NAVICEPEHEMERISB ONNEW
LOG RAWALMB ONNEW
LOG GLORAWALMB ONNEW
LOG GALALMANACB ONNEW
LOG BDSALMANACB ONNEW
LOG QZSSALMANACB ONNEW
LOG NAVICALMANACB ONNEW
LOG IONUTC B ONNEW
LOG GLOCLOCKB ONNEW
LOG GALCLOCKB ONNEW
LOG BDSCLOCKB ONNEW
LOG TRACKSTATB ONTIME 1
LOG RANGE B ONTIME 0.5
LOG BESTPOSB ONTIME 1
LOG SATVIS2B ONTIME 30
LOG ITDETECTSTATUSB ONCHANGED
```

For dual antenna receivers, add these logs:

```
LOG TRACKSTATB_1 ONTIME 1
LOG RANGE_B_1 ONTIME 0.5
```

For interference issues add this log:

```
LOG ITPSDDETECTB ONNEW
```

For interference issues, when you have enough datalink bandwidth to handle large logs, add this log:

```
LOG ITPSDFINALB ONNEW
```

SPAN troubleshooting logs

```
LOG RXSTATUSB ONCHANGED
LOG RAWEPHEMB ONNEW
LOG GLORAWEPHEMB ONNEW
LOG GALINAVRAWEPHEMERISB ONNEW
LOG BDSEPHEMERISB ONNEW
LOG BESTPOSB ONTIME 1
LOG RANGE_B ONTIME 0.5
LOG RXCONFIGA ONCE
LOG VERSIONA ONCE
LOG RAWIMUSXB ONNEW
LOG INSUPDATESTATUSB ONCHANGED
LOG INSPVAXB ONTIME 1
LOG INSCONFIGA ONCHANGED
LOG BESTGNSSPOSB ONTIME 1
```

RTK troubleshooting logs

```
LOG RXSTATUSB ONCHANGED
LOG RAWEPHEMB ONNEW
LOG GLORAWEPHEMB ONNEW
LOG QZSSRAWEPHEMB ONNEW
LOG BDSRAWNAVSUBFRAMEB ONNEW
LOG GALFNAVRAWEPHEMERISB ONNEW
LOG GALINAVRAWEPHEMERISB ONNEW
LOG RANGE_B ONTIME 0.5
LOG BESTPOSB ONTIME 1.0
LOG RXCONFIGB ONCE
LOG VERSIONB ONCE
LOG TRACKSTATB ONTIME 1.0
LOG RTKPOSB ONTIME 1.0
LOG MATCHEDPOSB ONNEW
LOG MATCHEDSATS ONNEW
LOG RTKSATS ONTIME 1.0
LOG PSRPOSB ONTIME 1.0
LOG RAWALMB ONNEW
LOG IONUTCB ONNEW
LOG GLORAWALMB ONNEW
LOG GLOCLOCKB ONNEW
LOG PASSTHROUGHB ONNEW
LOG CLOCKMODELB ONTIME 1.0
LOG REFSTATIONB ONNEW
LOG RTKVELB ONTIME 1.0
```

PPP troubleshooting logs

```
LOG RXSTATUSB ONCHANGED
LOG GPSEPHEMB ONNEW
LOG GLOEPHEMERISB ONNEW
LOG QZSSEPHEMERISB ONNEW
LOG BDSEPHEMERISB ONNEW
LOG BDSBCNAV1EPHEMERISB ONNEW
LOG BDSBCNAV2EPHEMERISB ONNEW
LOG BDSBCNAV3EPHEMERISB ONNEW
LOG GALFNAVEPHEMERISB ONNEW
LOG GALINAVEPHEMERISB ONNEW
LOG RANGE ONTIME 0.5
LOG BESTPOSB ONTIME 1.0
LOG RXCONFIGB ONCE
LOG VERSIONB ONCE
LOG TRACKSTATB ONTIME 10.0
LOG LBANDTRACKSTATB ONTIME 1.0
LOG PPPPOSB ONTIME 1.0
LOG PPPSATSB ONTIME 1.0
LOG TERRASTARINFOB ONCHANGED
LOG TERRASTARSTATUSB ONCHANGED
LOG PSRPOSB ONTIME 1.0
LOG ALMANACB ONNEW
LOG GLOALMANACB ONNEW
LOG GALALMANACB ONNEW
LOG BDSALMANACB ONNEW
LOG QZSSALMANACB ONNEW
LOG IONUTCB ONNEW
LOG GLOCLOCKB ONNEW
LOG LBANDBEAMTABLEB ONCHANGED
```

ALIGN troubleshooting logs

```
LOG RXSTATUSB ONCHANGED
LOG RAWEPHEMB ONNEW
LOG GLORAWEPHEMB ONNEW
LOG GALINAVRAWEPHEMERISB ONNEW
LOG BDSEPEHEMERISB ONNEW
LOG BESTPOSB ONTIME 1
LOG RANGE_B ONTIME 0.5
LOG RXCONFIGA ONCE
LOG VERSIONA ONCE
LOG LOGLISTA ONCE
LOG PORTSTATSA ONTIME 10
LOG ALIGNBSLNENUB ONNEW
LOG ALIGNBSLNXYZB ONNEW
LOG ALIGNDOPB ONNEW
LOG HEADING2B ONNEW
LOG MASTERPOSB ONNEW
LOG ROVERPOSB ONNEW (This log can only be output on a receiver where ALIGN is enabled.)
LOG HEADINGSATSA ONNEW (This log can only be output on a receiver where ALIGN is enabled and
configured as the ALIGN rover.)
LOG DUALANTENNAHEADINGB ONTIME 1.0
LOG TRACKSTATB_1 ONTIME 1 (dual antenna receivers only)
LOG RANGE_B_1 ONTIME 0.5 (dual antenna receivers only)
```

Chapter 1 OEM7 SPAN overview

NovAtel's SPAN GNSS+INS technology brings together two very different but complementary positioning and navigation systems namely Global Navigation Satellite System (GNSS) and an Inertial Navigation System (INS). By combining the best aspects of GNSS and INS into one system, SPAN technology is able to offer a solution that is more accurate and reliable than either GNSS or INS could provide alone. The combined GNSS+INS solution has the advantage of the absolute accuracy available from GNSS and the continuity of INS through traditionally difficult GNSS conditions.

The SPAN system consists of the following components:

- NovAtel OEM7 receiver
These receivers are capable of receiving and tracking different combinations of GPS, GLONASS, Galileo, BeiDou, NavIC and QZSS signals. OEM7 receivers can also allocate channels for the reception of correction service signals from SBAS (standard) and TerraStar PPP (optional). OEM7 adaptability offers multi-system, frequency, and size configurations for any application requirement. Patented Pulsed Aperture Correlator (PAC) technology combined with a powerful microprocessor enable multipath-resistant processing. Excellent acquisition and re-acquisition times allow this receiver to operate in environments where very high dynamics and frequent interruption of signals can be expected. The OEM7 receiver also supports the timing requirements of the IMU and runs the real-time INS filter.
- IMU
The Inertial Measurement Unit (IMU) consists of three accelerometers and three gyroscopes (gyros) so that accelerations along specific axes and angular rotations can be measured. Several IMU types are supported and are listed in *Table 3: SPAN-compatible IMUs* on page 30.
- GNSS antenna

The GNSS receiver is connected to the IMU with an RS-232, RS-422 or SPI link. A NovAtel GNSS antenna must also be connected to the receiver to track GNSS signals. After the IMU enclosure, GNSS antenna and appropriate power supplies are attached, and a few simple configuration commands are entered, the SPAN system will be ready to navigate.

1.1 Fundamentals of GNSS+INS

GNSS positioning observes range measurements from orbiting GNSS satellites. From these observations, the receiver can compute position and velocity with high accuracy. NovAtel GNSS positioning systems are highly accurate positioning tools. However, GNSS in general has some restrictions which limit its usefulness in some situations. GNSS positioning requires line of sight view to at least four satellites simultaneously. If these criteria are met, differential GNSS positioning can be accurate to within a few centimetres. If however, some or all of the satellite signals are blocked, the accuracy of the position reported by GNSS degrades substantially, or may not be available at all.

In general, an INS uses forces and rotations measured by an IMU to calculate position, velocity and attitude. This capability is embedded in the firmware of OEM7 receivers. Forces are measured by accelerometers in three perpendicular axes within the IMU and the gyros measure angular rotation rates around those axes. Over short periods of time, inertial navigation gives very accurate acceleration, velocity and attitude output. The INS must have prior knowledge of its initial position, initial velocity, initial attitude, Earth rotation rate and gravity field. Since the IMU measures changes in orientation and acceleration, the INS determines changes in position and attitude, but initial values for these parameters must be provided from an external source. Once these parameters are known, an INS is capable of providing an autonomous solution with no external inputs. However, because of errors in the IMU measurements that accumulate over time, an inertial-only solution degrades with time unless external updates such as position, velocity or attitude are supplied.

The SPAN system's combined GNSS+INS solution integrates the raw inertial measurements with all available GNSS information to provide the optimum solution possible in any situation. By using the high accuracy GNSS solution, the IMU errors can be modelled and mitigated. Conversely, the continuity and relative accuracy of the INS solution enables faster GNSS signal reacquisition and RTK solution convergence.

The advantages of using SPAN technology are its ability to:

- Provide a full attitude solution (roll, pitch and azimuth)
- Provide continuous solution output (in situations when a GNSS-only solution is impossible)
- Provide faster signal reacquisition and RTK solution resolution (over stand-alone GNSS because of the tightly integrated GNSS and INS filters)
- Output high-rate (up to the IMU data rate depending on your logging selections) position, velocity and attitude solutions for high-dynamic applications, see also *Logging restriction important notice* on page 109
- Use raw phase observation data (to constrain INS solution drift even when too few satellites are available for a full GNSS solution)



For more information about GNSS and INS, refer to *An Introduction to GNSS* available on our website at novatel.com/an-introduction-to-gnss

1.2 SPAN models and features

SPAN GNSS+INS functions are optional features authorized through a subscription or software model upgrade. SPAN is commonly used in conjunction with precision GNSS corrections services such as SmartNet, RTK or TerraStar PPP. A minimum of dual-frequency tracking is recommended.

The SPAN features enabled on a receiver are identified in the 10th and 11th characters of the OEM7 model string. For example, if the model string is FFNRNNTBNS1, the characters **S1** identify the SPAN features. The 10th character (S in this example) identifies the INS Options. The 11th character (1 in this example) identifies the IMU grade. If the 10th and 11th characters are not present in the model number, SPAN has not been enabled on the receiver.



The model string is viewed using the **VERSION** log.

The SPAN features can also be viewed using the **MODELFEATURES** log.

1.2.1 INS options

For firmware versions earlier than OEM 7.08, the INS Model character indicates which INS features are enabled by the model. See *Table 1: INS options (previous to OEM 7.08)* on the next page.

For firmware versions OEM 7.08 and later, any INS Model enables all of the INS features. See *Table 2: INS options (OEM 7.08 and later)* on the next page.

Table 1: INS options (previous to OEM 7.08)

INS model	Meaning	Description	Functionality inheritance
S	SPAN Enabled	Standard SPAN functionality. This model enables most SPAN functionality.	S
P	Enhanced Profiles	Allows the use of enhanced INS profiles for certain applications. For example, dead reckoning performance is controlled using the LAND Profile and Heave filter output is controlled using the MARINE Profile. For information about INS Profiles, see <i>INS Profiles</i> on page 85. For information about enabling and disabling INS Profiles, see the SETINSPROFILE command.	S+P
R	Relative INS	Allows for two SPAN systems to communicate and produce a relative solution (position, velocity, attitude) between them. This option also inherits the enhanced profile functionality of the P model. For more information, see <i>Relative INS</i> on page 137.	S+P+R

Table 2: INS options (OEM 7.08 and later)

INS model	Meaning	Description
S, P or R	SPAN Enabled	Standard SPAN functionality. This model enables most SPAN functionality.
	Enhanced Profiles	Allows the use of enhanced INS profiles for certain applications. For example, dead reckoning performance is controlled using the LAND Profile and Heave filter output is controlled using the MARINE Profile. For information about INS Profiles, see <i>INS Profiles</i> on page 85. For information about enabling and disabling INS Profiles, see the SETINSPROFILE command.
	Relative INS	Allows for two SPAN systems to communicate and produce a relative solution (position, velocity, attitude) between them. This option also inherits the enhanced profile functionality of the P model. For more information, see <i>Relative INS</i> on page 137.  To operate Relative INS, a Y model is required in the 5th character of the OEM7 model string (e.g. FFNRYNTBNS1).

1.2.2 IMU grade

The IMU grade indicates which classes of IMUs are supported by the model. The IMU grade is specified as a number between 1 and 3 to indicate the IMU grade available to the model.

So, for example, to use an IMU-ISA-100C, an IMU grade of 3 is required. A larger number also allows use of any IMU in a lower grade. So the S3 model required for the IMU-ISA-100C would also allow the use of any IMU in grades 1 and 2.

Table 3: SPAN-compatible IMUs on the next page shows the IMU grade classification.

Table 3: SPAN-compatible IMUs

IMU grade	IMU name	IMU data rate
1	IMU-CPT	100 Hz
	OEM-HG1930 (CA50)	100 Hz
	OEM-IMU-ADIS-16488 IMU-IGM-A1	200 Hz
	OEM-IMU-STIM300 IMU-IGM-S1	125 Hz
	OEM-IMU-EG320N	125 Hz
	OEM-IMU-EG320N (200 Hz)	200 Hz
	OEM-IMU-EG370N	200 Hz
	OEM-IMU-HG4930 (AN01)	100 Hz
	OEM-IMU-HG4930 (AN04)	100 Hz
2	IMU-HG1900 (CA50) OEM-HG1900 (CA50)	100 Hz
	UIMU-HG1700-AG58	100 Hz
	UIMU-HG1700-AG62	100 Hz
	OEM-IMU-HG4930-(AN04) (400 Hz)	400 Hz
	IMU-KVH1750	200 Hz
	IMU-P1750	200 Hz
	IMU- μ IMU-IC OEM-IMU- μ IMU-IC	200 Hz
	OEM-IMU- μ IMU-IC-UART (400 Hz)	400 Hz
3	IMU-FSAS	200 Hz
	IMU-ISA-100C OEM-IMU-ISA-100C	200 Hz
	IMU-LN200 IMU-LN200C UIMU-LN200	200 Hz

1.3 Related documents and information

This manual contains information about the installation and operation of the SPAN system. It is beyond the scope of this manual to provide details on service or repair. Contact your local NovAtel dealer for any customer service related inquiries, see *Customer Support* on page 22.

The OEM7 receiver utilizes a comprehensive user-interface command structure, which requires communications through its communications ports. For descriptions of the commands and logs available with OEM7 receivers, refer to the [OEM7 Commands and Logs Reference Manual](#) available on the NovAtel website at novatel.com/support. It is recommended that these documents be kept together for easy reference.

For more information about the OEM7 receivers, refer to the [OEM7 Installation and Operation User Manual](#), [CPT7 Installation and Operation User Manual](#), [PwrPak7 Installation and Operation User Manual](#) or [SMART7 Installation and Operation User Manual](#).

SPAN system output is compatible with post-processing software from NovAtel's Waypoint Products Group. Visit our web site at novatel.com/products/waypoint-software for details.

Chapter 2 SPAN installation

A SPAN system consists of an OEM7 receiver, an IMU, a GNSS antenna, power and a communication link (if your application requires real time differential operation). The installation process varies based on the OEM7 receiver.

- *OEM7 receiver card installation* on the next page
- *PwrPak7 installation* on page 35

The *SPAN installation* section focuses on adding an IMU to the GNSS system.



OEM7 receivers with integrated IMUs do not need additional installation steps.

For information about installing a PwPwrPak7-E1, PwrPak7D-E1, PwrPak7D-E1, PwrPak7-E2 or PwrPak7D-E2, refer to [PwrPak7 Installation and Operation User Manual](#).

For information about installing a CPT7 or CPT7700, refer to [CPT7 Installation and Operation User Manual](#).

For information about installing a SMART7-S, refer to [SMART7 Installation and Operation User Manual](#).

For these receivers continue to *SPAN operation* on page 76.



If your IMU enclosure and IMU were supplied separately, additional instructions for installing the IMU into an enclosure are available in the following appendices: *HG1700 IMU in Universal Enclosure* on page 302, *LN-200 IMU in Universal enclosure* on page 311, *HG1700 IMU in SPAN HG enclosure* on page 318 and *LN-200 IMU in SPAN IMU enclosure* on page 324.



Prior to installation of a CPT7 system, please review the following sections:

Importance of lever arms on page 96

Importance of RBV calibration on page 98

Importance of antenna location for ALIGN on page 99

Vibration considerations on page 83

Following these guidelines will help deliver the best performance from the system.

2.1 OEM7 receiver card installation

The following diagram shows a typical SPAN installation using an OEM7 receiver card and an IMU in an enclosure.

Figure 1: Typical installation of a SPAN system with an OEM7 receiver card

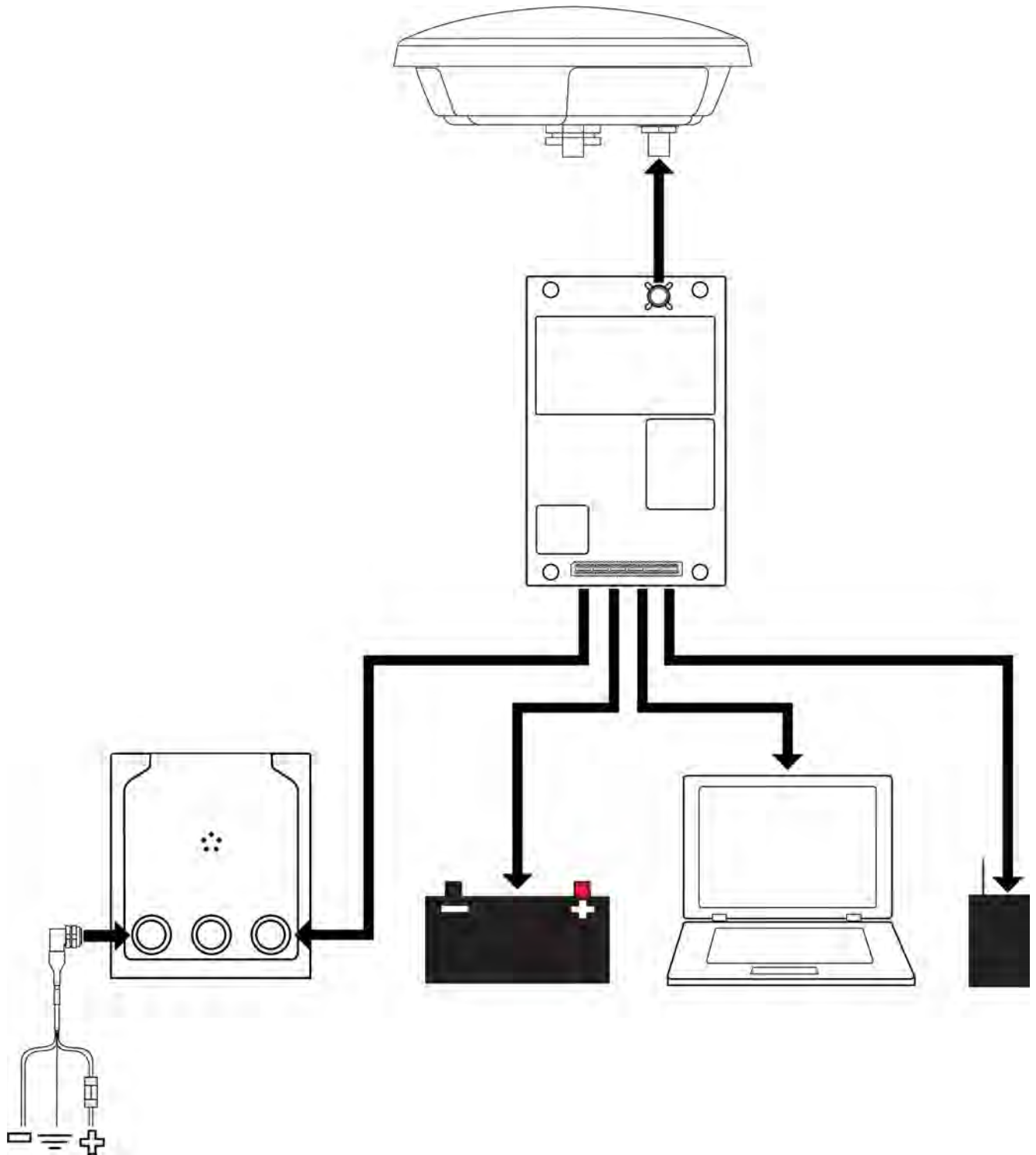

Complete the following steps to set up your NovAtel SPAN system.

1. Mount the GNSS antenna.

Refer to the [OEM7 Installation and Operation User Manual](#) for information about mounting a GNSS antenna.

2. Mount the IMU.

See *Mount the IMU* on page 36 for details.

3. Install the OEM7 receiver card.

See the [OEM7 Installation and Operation User Manual](#) for information about installing an OEM7 receiver.

4. Connect the GNSS antenna to the OEM7 receiver card.

See the [OEM7 Installation and Operation User Manual](#) for information connecting the GNSS antenna to an OEM7 receiver.

5. Connect the IMU to the OEM7 receiver.

See *Connect the IMU to the OEM7 receiver card* on page 38 for details.

6. Connect the I/O strobe signals (optional).

See the [OEM7 Installation and Operation User Manual](#) for information about connecting the strobe signals to an OEM7 receiver.

7. Connect power to the IMU and receiver.

Ensure an appropriately rated fuse is incorporated in the power wiring.

See *Connect power* on page 58 for details.

8. Connect a data communication device, such as a computer, to the receiver. A data communication device is used to configure and monitor the receiver.

See the [OEM7 Installation and Operation User Manual](#) for information about connecting a communication device to an OEM7 receiver.

2.2 PwrPak7 installation

The following diagram shows a typical SPAN installation using a PwrPak7 and an IMU in an enclosure.

Figure 2: Typical installation of a SPAN system with a PwrPak7

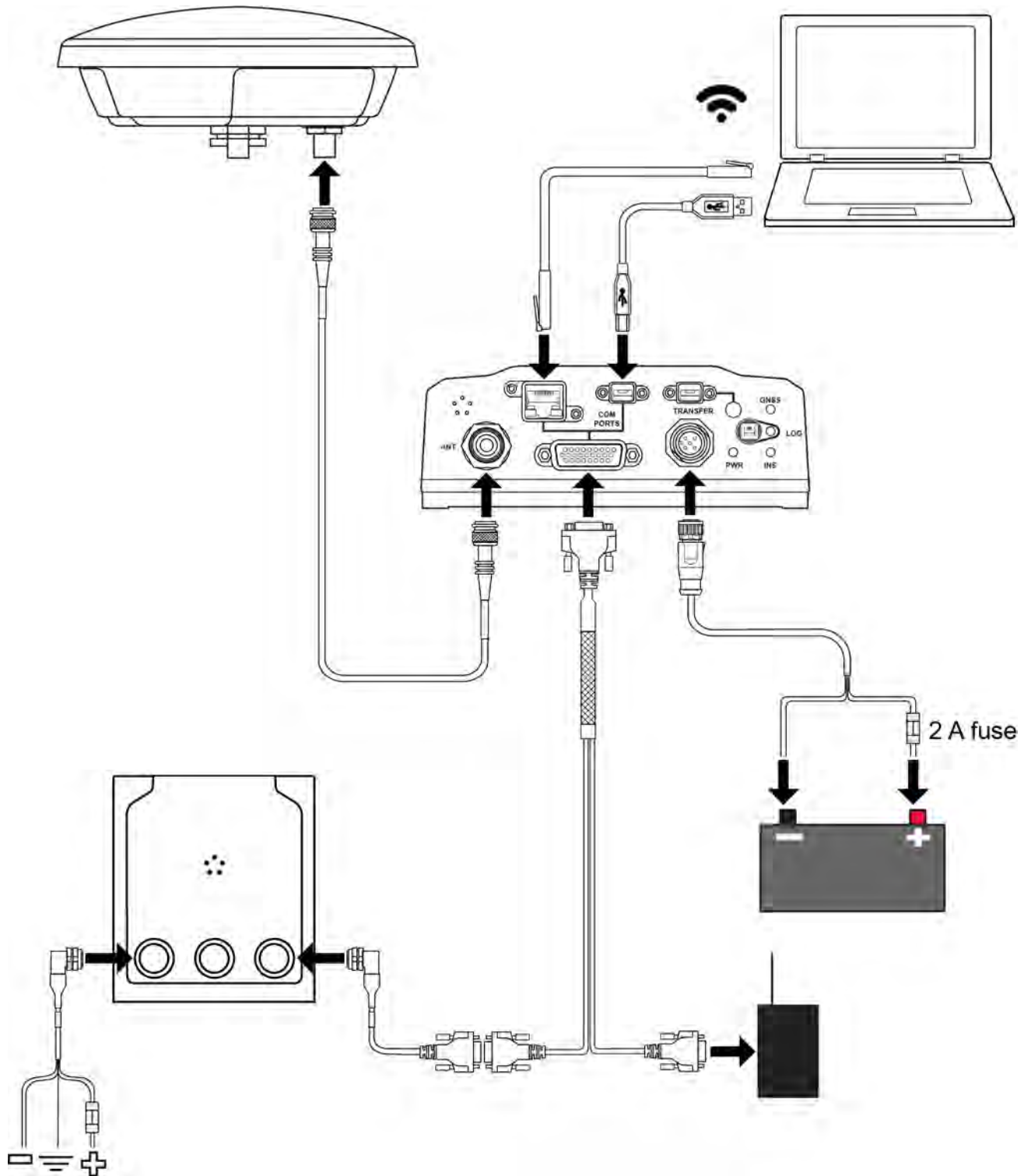

Complete the following steps to set up your NovAtel SPAN system.

1. Mount the GNSS antenna.

See the [PwrPak7 Installation and Operation User Manual](#) for information about mounting the GNSS antenna.

2. Mount the IMU.

See *Mount the IMU* below for details.

3. Mount the PwrPak7.

See the [PwrPak7 Installation and Operation User Manual](#) for information about mounting a PwrPak7.

4. Connect the antenna cable from the GNSS antenna to the ANT port on the PwrPak7.

For PwrPak7D, connect the primary GNSS antenna to the ANT 1 port and the secondary GNSS antenna to the ANT 2 port.

5. Connect the IMU to the PwrPak7.

See *Connect the IMU to the PwrPak7* on page 57 for details.

6. Connect the I/O strobe signals (optional).

See the [PwrPak7 Installation and Operation User Manual](#) for information about connecting I/O signals to a PwrPak7.

7. Connect power to the IMU and receiver.

See *Connect power* on page 58 for details.

8. Connect a data communication device, such a computer, to the receiver. A data communication device is used to configure and monitor the receiver.

See the [PwrPak7 Installation and Operation User Manual](#) for information about connecting a data communication device to a PwrPak7.

2.3 Mount the IMU

Mount the IMU in a fixed location where the distance from the IMU to the GNSS antenna phase centre is constant. Ensure that the orientation with respect to the vehicle and antenna is also constant.

For attitude output to be meaningful, the IMU should be mounted such that the positive Z-axis marked on the IMU enclosure points up and the Y-axis points forward through the front of the vehicle, in the direction of track. If the IMU is not mounted in this orientation, a rotational offset must be applied. See *Rotational offsets* on page 80 for more information.

Also, it is important to measure the distance from the IMU to the antenna (the Antenna Lever Arm), on the first usage, on the axis defined on the IMU enclosure. See *Lever arm calibration routine* on page 110. See also *IMU technical specifications* on page 144 for dimensional drawings of the IMU enclosures.

Ensure the IMU cannot move due to dynamics and that the distance and relative direction between the antenna and the IMU is fixed. See *SPAN configuration* on page 87.



The closer the antenna is to the IMU, particularly in the horizontal plane, the more accurate the position solution.

Also, your measurements entered using the **SETINSTRANSLATION** command must be as accurate as possible, or at least more accurate than the GNSS positions being used. **For example, a 10 cm error in recording the antenna offset will result in at least a 10 cm error in the output. Millimetre accuracy is preferred.**

The offset from the IMU to the antenna, and/or a user point device, must remain constant especially for RTK or DGPS data. Ensure the IMU, antenna and user point device are bolted in one position perhaps by using a custom bracket.

2.3.1 Securing the IMU Enclosure

The IMU Enclosure (IMU-ISA-100C, IMU-LN200, IMU-LN200C, IMU-HG1900 and IMU- μ IMU-IC) can be secured directly to the mounting surface or can be secured using the IMU Enclosure Mounting Plate.

To secure the IMU Enclosure directly to the mounting surface, use four M6 screws that pass through the mounting surface and into the bottom of the IMU Enclosure. For the location and spacing of the mounting holes, refer to the mechanical drawings of the IMU in *IMU technical specifications* on page 144.



The optimal screw penetration into the IMU Enclosure mounting holes is 5.0 to 6.0 mm deep. When selecting screws for mounting the IMU Enclosure, ensure the screw penetration does not exceed 6 mm. Using excessively long screws can damage the IMU Enclosure.



The mounting screws should be torqued to 42 to 45 in-lbs.

For information about securing the IMU Enclosure using the mounting plate, refer to *Secure an IMU enclosure using the mounting plate* below.



Other IMUs are secured using the four through holes in the base of the IMU.

2.3.2 Secure an IMU enclosure using the mounting plate

To secure an IMU enclosure using the IMU enclosure mounting plate:

1. Place the mounting plate on the bottom of the IMU Enclosure and align the holes in the mounting plate with the threaded holes in the IMU Enclosure base plate.
2. Secure the mounting plate to the IMU Enclosure using the 4 screws (M6 x 8 mm) included with the mounting plate.
3. Secure the IMU Enclosure mounting plate to the mounting location using 4 M6 screws.

Figure 3: IMU enclosure mounting plate

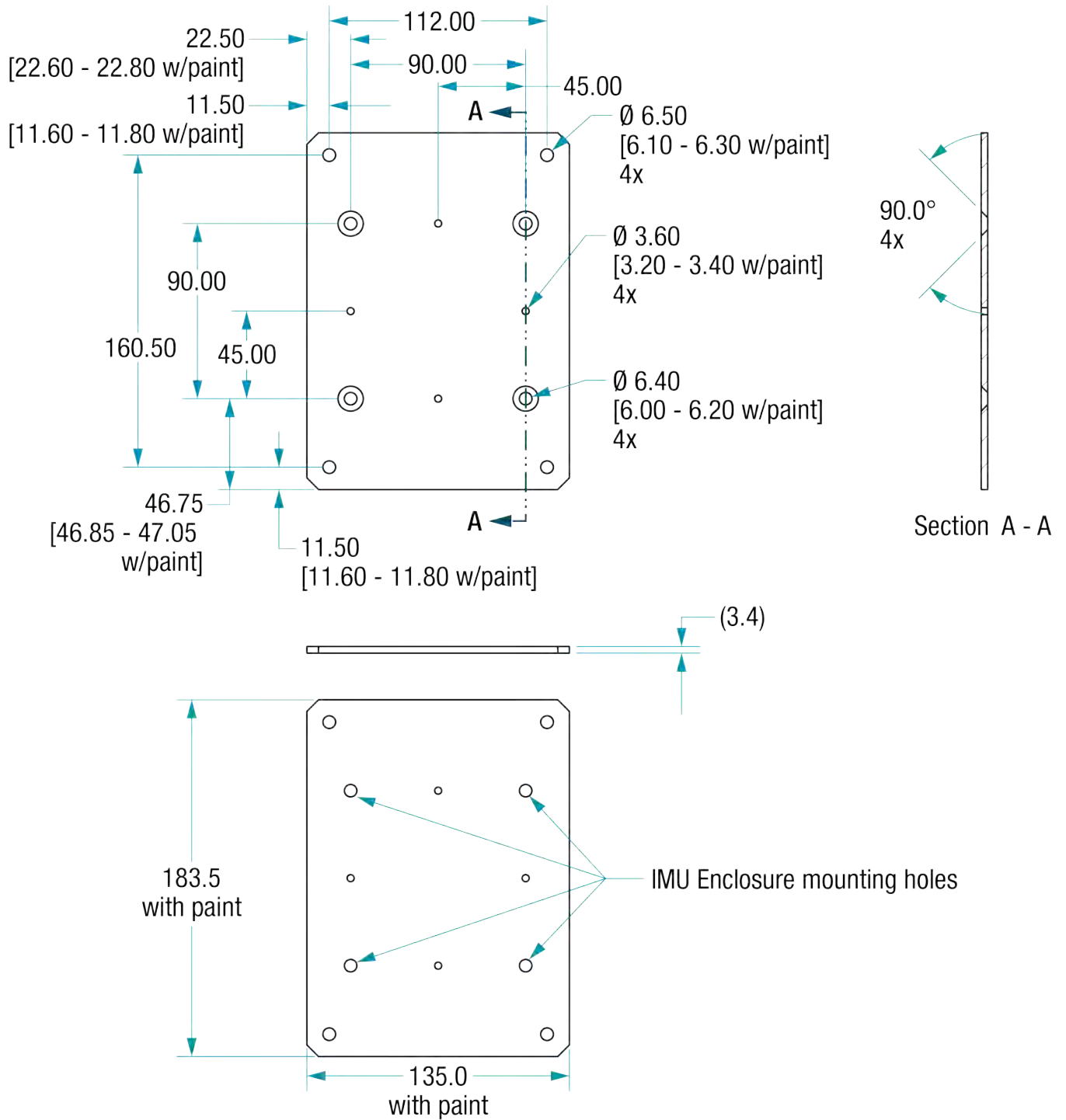

2.4 Connect the IMU to the OEM7 receiver card

The method used to connect the IMU depends on the IMU and OEM7 receiver in the system. IMUs that are contained within an IMU enclosure communicate with the OEM7 receiver using a serial port. IMUs not contained in an IMU enclosure communicate with the OEM7 receiver either through an interface card (MIC or UIC) or direct connection (SPI or Serial).

IMUs in an enclosure typically have *IMU* or *UIMU* at the start of their names (for example, IMU-ISA-100C, IMU- μ IMU-IC or IMU-IGM-S1).

IMUs not in an IMU enclosure typically have *OEM* at the start of their names (for example, OEM-IMU-ISA-100C, OEM-IMU- μ IMU or OEM-IMU-STIM300).

Table 4: IMU connection method

IMU	Interface card	Event signal	Receiver connection method	Receiver
IMU-CPT	No	Event Out	Serial port (RS-422)	OEM719, OEM729, OEM7600, OEM7700, OEM7720, PwrPak7
IMU-FSAS	No	Event Out	Serial port (RS-422)	OEM719, OEM729, OEM7600, OEM7700, OEM7720, PwrPak7
IMU-KVH1750	No	Event Out	Serial port (RS-422)	OEM719, OEM729, OEM7600, OEM7700, OEM7720, PwrPak7
IMU-P1750	No	Event Out	Serial port (RS-422)	OEM719, OEM729, OEM7600, OEM7700, OEM7720, PwrPak7
IMU-H58 IMU-H62	Yes – Enclosure	N/A	Serial port (RS-422)	OEM719, OEM729, OEM7600, OEM7700, OEM7720, PwrPak7
UIMU-HG1700-A58 UIMU-HG1700-A62	Yes – Enclosure	N/A	Serial port (RS-422)	OEM719, OEM729, OEM7600, OEM7700, OEM7720, PwrPak7
IMU-HG1900	Yes – Enclosure	N/A	Serial port (RS-422)	OEM719, OEM729, OEM7600, OEM7700, OEM7720, PwrPak7
IMU-ISA-100C	Yes – Enclosure	N/A	Serial port (RS-422)	OEM719, OEM729, OEM7600, OEM7700, OEM7720, PwrPak7
IMU-LN200 IMU-LN200C	Yes – Enclosure	N/A	Serial port (RS-422)	OEM719, OEM729, OEM7600, OEM7700, OEM7720, PwrPak7
IMU-LN200 (SPAN IMU enclosure)	Yes – Enclosure	N/A	Serial port (RS-422)	OEM719, OEM729, OEM7600, OEM7700, OEM7720, PwrPak7
UIMU-LN200	Yes – Enclosure	N/A	Serial port (RS-422)	OEM719, OEM729, OEM7600, OEM7700, OEM7720, PwrPak7
IMU- μ IMU-IC	Yes – Enclosure	N/A	Serial port (RS-422)	OEM719, OEM729, OEM7600, OEM7700, OEM7720, PwrPak7
IMU-IGM-A1	Yes – Enclosure	N/A	Serial port (RS-232 or RS-422)	OEM719, OEM729, OEM7600, OEM7700, OEM7720, PwrPak7
IMU-IGM-S1	Yes - Enclosure	N/A	Serial port (RS-232 or RS-422)	OEM719, OEM729, OEM7600, OEM7700, OEM7720, PwrPak7
OEM-IMU-HG1900	Yes - SDLC or UIC	N/A	Serial port (RS-422)	OEM719, OEM729, OEM7600, OEM7700, OEM7720, PwrPak7

IMU	Interface card	Event signal	Receiver connection method	Receiver
OEM-IMU-HG1930	Yes – SDLC or UIC	N/A	Serial port (RS-422)	OEM719, OEM729, OEM7600, OEM7700, OEM7720
OEM-IMU-ISA-100C	Yes – UIC	N/A	Serial port (RS-422)	OEM719, OEM729, OEM7600, OEM7700, OEM7720
OEM-IMU- μ IMU	Yes – UIC	N/A	Serial port (RS-422)	OEM719, OEM729, OEM7600, OEM7700, OEM7720, PwrPak7
OEM-IMU- μ IMU-IC-UART	No	Event In	Serial port (RS-422)	OEM719, OEM729, OEM7600, OEM7700, OEM7720, PwrPak7
OEM-IMU-STIM300	No	Event In	Serial port (RS-422)	OEM719, OEM729, OEM7600, OEM7700, OEM7720, PwrPak7
OEM-IMU-HG4930	No	PPS	Serial port (TTL)	OEM719, OEM729, OEM7600, OEM7700, OEM7720, PwrPak7
OEM-IMU-ADIS-16488	No	Event In & Event Out	SPI port	OEM7600, OEM7700, OEM7720
OEM-IMU-EG320N	No	Event In	SPI port	OEM7600, OEM7700, OEM7720
OEM-IMU-EG370N	No	Event In	SPI port	OEM7600, OEM7700, OEM7720

2.4.1 Connect an IMU enclosure to an OEM7 receiver card using a serial port

An interface is needed between the OEM7 receiver card and IMU that provides:

- Communication signals to the OEM7 receiver
- A serial port connection between the IMU and receiver
- Power to the receiver
- Power to the IMU

For information about the interface requirements for the OEM7 receiver card, see the [OEM7 Installation and Operation User Manual](#).

For information about the interface to the IMU, refer to the technical specifications of the IMU in *IMU technical specifications* on page 144.

The interface between the OEM7 receiver card and IMU must include circuitry to convert from the LVCMOS signal levels of the receiver COM port to the RS-232 or RS-422 signal levels of the IMU COM port.

The exception is COM1 on the OEM729 which provides either RS-232 or RS-422 signal levels.



If using an IMU-KVH1750 or IMU-P1750 not purchased through NovAtel, the baud rate of the IMU must be changed to 460,800 bps and the output method changed to MSYNC,EXT. For information about changing these parameters, see *IMU-KVH1750 and IMU-P1750 baud rate conversion* on page 56.

2.4.2 Connect an OEM IMU to an OEM7 receiver card using a UIC

The UIC provides power to the IMU and communication between the IMU and receiver. For information about using a UIC, see *UIC installation* on page 71.

2.4.3 Connect an OEM IMU to an OEM7 receiver card using a MIC

The MIC provides power to the IMU and communication between the IMU and receiver. For information about using a MIC, see *MIC installation* on page 61.

2.4.4 Connect an OEM IMU to an OEM7 receiver card using a direct connection

Some OEM IMUs can communicate with the OEM7 receiver card without using an interface card. For information about using a direct connection, see:

- *Connect an OEM-IMU-ADIS-16488 directly to an OEM7 receiver card below*
- *Connect an OEM-IMU-EG320N or OEM-IMU-EG370N directly to an OEM7 receiver card on page 43*
- *Connect an OEM-IMU-STIM300 directly to an OEM7 receiver on page 45*
- *Connect an OEM-IMU-HG4930 directly to an OEM7 receiver on page 48*
- *Connect an OEM-IMU- μ IMU-IC-UART directly to an OEM7 receiver on page 52*

2.4.5 Connect an OEM-IMU-ADIS-16488 directly to an OEM7 receiver card

The OEM-IMU-ADIS-16488 can connect directly to SPI capable OEM7 receivers, such as the OEM7600, OEM7700 and OEM7720, using a SPI connection. The SPI connection handles timing and data communication between the receiver and IMU.



The OEM-IMU-ADIS-16488 can also connect to any OEM7 receiver using a MEMS Interface Card (MIC). For information about using a MIC, see *MIC installation* on page 61.

The interface to the OEM-IMU-ADIS-16488 must provide:

- a Samtec CLM-112-02 connector
This connector mates with the connector on the OEM-IMU-ADIS-16488. See *Figure 4: OEM-IMU-ADIS-16488 pin locations* on the next page for the location of the IMU connector and pins.
- a SPI port connection to the OEM7 receiver
Refer to the following table for the connections required between the IMU and receiver. For information about the receiver connector, see the [OEM7 Installation and Operation User Manual](#).
- a 3.3 VDC (± 0.3 VDC) regulated power supply
Refer to the following table for the location of the power supply connections.



Install a user supplied 0.5 A slow blow fuse to the positive pole of the power source to protect the power supply wiring and your warranty.

Figure 4: OEM-IMU-ADIS-16488 pin locations

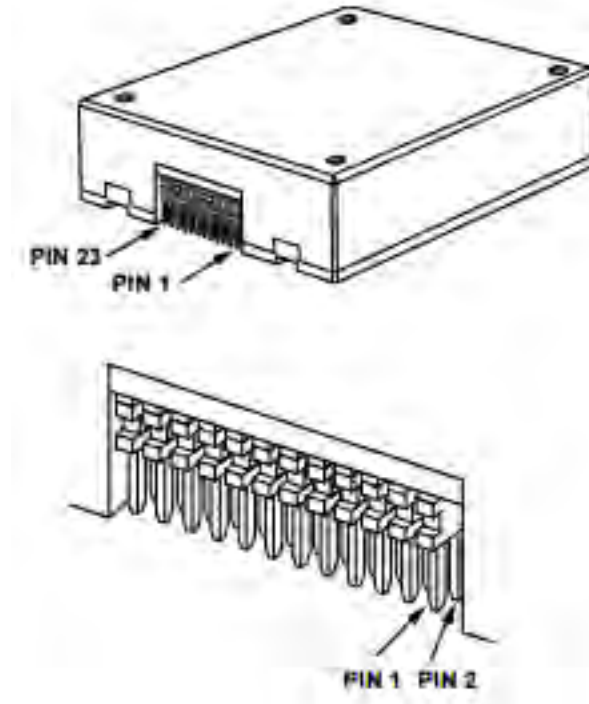

Pins not shown on the following table are not connected.

Table 5: Receiver to OEM-IMU-ADIS-16488 pin connections

ADIS-16488		Receiver		Description
Pin	Pin name	Pin	Pin name	
3	SCLK	44	SPI_SCLK	SPI Serial Clock
4	SDO	43	SPI_MISO	SPI Data Output
5	SDI	41	SPI_MOSI	SPI Data Input
6	$\overline{\text{CS}}$	42	SPI_nCS	SPI Chip Select
7	DIO1	26	EVENT_OUT2	Synchronization signal

ADIS-16488		Receiver		
Pin	Pin name	Pin	Pin name	Description
8	$\overline{\text{RST}}$	–	–	<p>Reset IMU</p> <p>RST must be high for the IMU to be active.</p> <p>To enable the IMU when the receiver is powered on, connect this pin to Pin 1 or Pin 2 of the receiver interface connector through a 10 kΩ resistor (recommended).</p> <p>Can also connect this pin to any stable 3.3 VDC power supply or output configuration to have more control over when IMU is enabled. When using this configuration note that:</p> <ul style="list-style-type: none"> pin 8 must be pulled low for greater than 100 ms to properly soft-reset the IMU pin has an internal pull-up resistor
9	DIO2	29	EVENT_IN2	Data ready
10-12	VDD	–	–	3.3 VDC power supply
13-15	GND	–	–	Digital ground



In the table above, the receiver pin numbers are for OEM7600, OEM7700 and OEM7720 receivers. For the location of the receiver card pins, refer to the [OEM7 Installation and Operation User Manual](#).

For more information about the OEM-IMU-ADIS-16488, see *OEM-IMU-ADIS-16488* on page 232.

2.4.6 Connect an OEM-IMU-EG320N or OEM-IMU-EG370N directly to an OEM7 receiver card



The information in this section applies to the OEM-IMU-EG320N (EG320N) and the OEM-IMU-EG370N (EG370N).

The OEM-IMU-EG320N and OEM-IMU-EG370N can connect directly to SPI capable OEM7 receivers, such as the OEM7600, OEM7700 or OEM7720, using a SPI connection. The SPI connection handles timing and data communication between the receiver and IMU.

The interface to the OEM-IMU-EG320N or OEM-IMU-EG370N must provide:

- a Samtec CLM-110-02-H-D connector

This connector mates with the connector on the OEM-IMU-EG320N or OEM-IMU-EG370N. See *Figure 5: OEM-IMU-EG320N/OEM-IMU-EG370N pin locations* on the next page for the location of the IMU connector and pins.

- a SPI port connection to the OEM7 receiver

See *Table 6: Receiver to OEM-IMU-EG320N/OEM-IMU-EG370N pin connections* below for the connections required between the IMU and receiver. For information about the receiver connector, see the [OEM7 Installation and Operation User Manual](#).

- a 3.3 VDC (± 0.15 VDC) regulated power supply

See *Table 6: Receiver to OEM-IMU-EG320N/OEM-IMU-EG370N pin connections* below for the location of the power supply connections.



Install a user supplied 0.25 A slow blow fuse to the positive pole of the power source to protect the power supply wiring and your warranty.

Figure 5: OEM-IMU-EG320N/OEM-IMU-EG370N pin locations

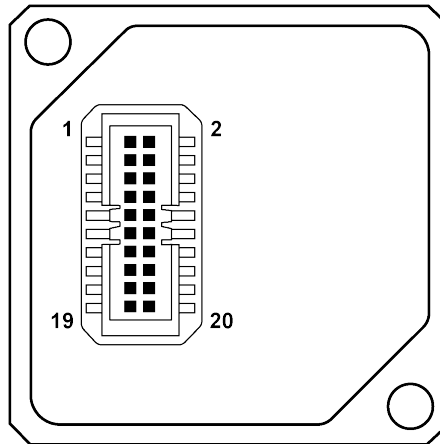

Pins not shown on the following table are not connected.

Table 6: Receiver to OEM-IMU-EG320N/OEM-IMU-EG370N pin connections

EG320N/EG370N		Receiver		Description
Pin	Pin name	Pin	Pin name	
1	SCLK	44	SPI_SCLK	SPI Serial Clock
2	SDO	43	SPI_MISO	SPI Data Output
3-4	GND	–	–	Digital ground
5	SDI	41	SPI_MOSI	SPI Data Input
6	$\overline{\text{CS}}$	42	SPI_nCS	SPI Chip Select
7	SOUT	–	–	UART Data Out Connect to the 3.3 VDC power supply through a resistor (default 10 k Ω).
8	GND	–	–	Digital ground

EG320N/EG370N		Receiver		Description
Pin	Pin name	Pin	Pin name	
9	SIN	–	–	UART Data In Connect to the 3.3 VDC power supply through a resistor (default 10 kΩ).
10-12	VCC	–	–	3.3 VDC power supply
13	DRDY (GPIO1)	29	EVENT_IN2	Data Ready
14	GPIO2 (EXT)	26	EVENT_OUT2	External Trigger
15	GND	–	–	Digital ground
16	$\overline{\text{RST}}$	–	–	Reset IMU RST must be high for the IMU to be active. To enable the IMU when the receiver is powered on, connect this pin to Pin 1 or Pin 2 of the receiver connector through a 10 kΩ resistor (recommended). Can also connect this pin to any stable 3.3 VDC power supply or output configuration to have more control over when IMU is enabled. When using this configuration note that: <ul style="list-style-type: none"> pin 16 must be pulled low for greater than 100 ms to properly soft-reset the IMU pin 16 has an internal 32-224 kΩ pull-up resistor



In the table above, the receiver pin numbers are for OEM7600, OEM7700 and OEM7720 receivers. For the location of the receiver card pins, refer to the [OEM7 Installation and Operation User Manual](#).

For more information about the OEM-IMU-EG320N, see *OEM-IMU-EG320N* on page 239. For information about the OEM-IMU-EG370N, see *OEM-IMU-EG370N* on page 245.

2.4.7 Connect an OEM-IMU-STIM300 directly to an OEM7 receiver

The OEM-IMU-STIM300 can connect directly to an OEM7 receiver using a serial port connection.



The OEM-IMU-STIM300 serial port uses RS-422 signal levels. Since most OEM7 receiver card ports use LVCMOS signal levels, a RS-422 line driver is needed to convert from LVCMOS to RS-422. The exception is COM1 on the OEM729 that operates at RS-232 or RS-422 levels.



The OEM-IMU-STIM300 can also connect to any OEM7 receiver using a MEMS Interface Card (MIC). For information about using a MIC, see *MIC installation* on page 61.

The interface to the OEM-IMU-STIM300 must provide:

- a Micro-D 15 pin male connector

This connector mates with the connector on the OEM-IMU-STIM300. See *Figure 6: OEM-IMU-STIM300 pinout* below for the IMU connector pin out.

- a RS-422 serial port connection to the OEM7 receiver

For most OEM7 receiver cards the connection must include a RS-422 line driver.

If using COM1 on an OEM729, a RS-422 line driver is not required. However, the COM1 protocol must be set to RS-422 using the **SERIALPROTOCOL** command.

Use COM1 or COM2 on the PwrPak7 to connect to the OEM-IMU-STIM300. These ports can be set to RS-422 protocol using the **SERIALPROTOCOL** command.

Refer to the following table for the connections required between the IMU and receiver. For information about the receiver connector, see the [OEM7 Installation and Operation User Manual](#).

- a 5.0 VDC (±0.5 VDC) regulated power supply

Refer to the following table for the location of the power supply connections.

 Install a user supplied 0.63 A slow blow fuse to the positive pole of the power source to protect the power supply wiring and your warranty.

Figure 6: OEM-IMU-STIM300 pinout



 Pins not shown on the following tables are not connected.

Table 7: OEM7 receiver card to OEM-IMU-STIM300 pin connections

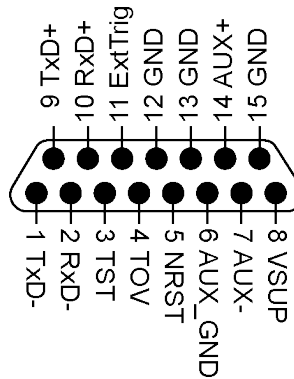
STIM300		RS-422 line driver		Receiver	Description
Pin	Pin name	Output	Input	Pin name	
1	STIM TxD-	RS422 B-	–	–	Part of RS-422 transmit pair from STIM300
2	STIM RxD-	RS422 A-	–	–	Part of RS-422 receive pair from STIM300



STIM300		RS-422 line driver		Receiver	
Pin	Pin name	Output	Input	Pin name	Description
4	STIM TOV	–	–	EVENT_IN2 OEM719: 7 OEM729: 7 OEM7600 : 29 OEM7700: 29 OEM7720: 29	 Interface Circuit Required The STIM TOV output uses 5V logic, but the OEM7 EVENT_IN lines are not 5V tolerant. A circuit to convert from 5V logic to 3.3V levels is required.
8	5V Pwr	–	–	–	
9	STIM TxD+	RS422 B+	–	–	Part of RS-422 transmit pair from STIM300
10	STIM RxD+	RS422 A+	–	–	Part of RS-422 receive pair from STIM300
12	GND	–	–	–	Any receiver ground pin
13	GND	–	–	–	Any receiver ground pin
15	GND	–	–	–	Any receiver ground pin
–	–	–	LVC MOS A IN	COMx_TXD	Any receiver COM port transmit and receive pair
–	–	–	LVC MOS B IN	COMx_RXD	
–	–	–	GND		Any receiver ground pin

Table 8: OEM729 COM1 or PwrPak7 to OEM-IMU-STIM300 pin connections

STIM300		Receiver		
Pin	Pin name	Pin	Pin name	Description
1	STIM TxD-	OEM729 COM1: 15 PwrPak7 COM1: 4 COM2: 12	COMx_RXD-	Part of RS-422 transmit pair from STIM300
2	STIM RxD-	OEM729 COM1: 17 PwrPak7 COM1: 1 COM2: 19	COMx_TXD-	Part of RS-422 receive pair from STIM300

STIM300		Receiver		
Pin	Pin name	Pin	Pin name	Description
4	STIM TOV	OEM729: 7 PwrPak7: 23	EVENT_ IN2	<div style="border: 1px solid red; padding: 5px; background-color: #ffe6e6;">  <p>Interface Circuit Required The STIM TOV output uses 5V logic, but the OEM729 EVENT_IN lines are not 5V tolerant. A circuit to convert from 5V logic to 3.3V levels is required on the OEM729.</p> </div> <p>The PwrPak7 input strobes are 5V tolerant and can be connected directly to the STIM TOV output.</p>
8	5V Pwr	–	–	5 VDC power supply
9	STIM TxD+	OEM729 COM1: 18 PwrPak7 COM1: 3 COM2: 20	COMx_ RXD+	Part of RS-422 transmit pair from STIM300
10	STIM RxD+	OEM729 COM1: 20 PwrPak7 COM1: 2 COM2: 10	COMx_ TXD+	Part of RS-422 receive pair from STIM300
12	GND	OEM729 GND: 1, 23, 24 PwrPak7 GND: 11, 14, 17	GND	Connect the STIM300 ground pin to any receiver ground pin. This establishes a common ground and ensures proper signal detection.
13	GND			
15	GND			



For the location of the receiver ground pins and transmit and receive pairs, refer to the [OEM7 Installation and Operation User Manual](#) or [PwrPak7 Installation and Operation User Manual](#).

2.4.8 Connect an OEM-IMU-HG4930 directly to an OEM7 receiver

The OEM-IMU-HG4930 can connect directly to an OEM7 receiver using a serial port connection.



The OEM-IMU-HG4930 serial port uses 5 V signal levels.

OEM7 receiver card COM ports are not 5 V tolerant. A circuit to convert from 5V logic to 3.3V levels is required.



SPAN supports the Honeywell HG4930-AN01 and HG4930-AN04 models only. Other models of the HG4930 are not supported.

The interface to the OEM-IMU-HG4930 must provide:

- a 2 x 7 header

This connector mates with the connector on the OEM-IMU-HG4930. The recommended connectors are:

Table 9: OEM-IMU-HG4930 mating connector

OEM-IMU-HG4930 connector	Mating connector
2 x 7 header	SAMTEC CLT-107-01-S-D
	DigiKey CLT-107-01-S-D-ND

- an interface circuit between the OEM-IMU-HG4930 and the OEM7 receiver

For most OEM7 receiver card COM ports, a circuit is required to convert from the 5 V levels used by the OEM-IMU-HG4930 to the 3.3 V levels used by the receiver.

For COM1 on the OEM729, a line driver is required for the COM port connection to convert from the 5 V levels on the OEM-IMU-HG4930 to RS-232 or RS-422. If using a RS-422 line driver, change the protocol of the receiver COM port to RS-422 using the **SETIMUPORTPROTOCOL** command.

Refer to the following tables for the connections required between the IMU and receiver. For information about the receiver connector, see the [OEM7 Installation and Operation User Manual](#).

- a 5.0 VDC (± 0.5 VDC) regulated power supply

Refer to the following tables for the location of the power supply connections.



Install a user supplied 1.6 A slow blow fuse to the positive pole of the power source to protect the power supply wiring and your warranty.

Direct connect an OEM7 receiver to the OEM-IMU-HG4930



Pins not shown on the following table are not connected.

Table 10: OEM7 receiver card to OEM-IMU-HG4930 pin connections

HG4930		Receiver	
Pin	Pin name	Pin name	Description
1	GND	–	Connect to power supply Ground and any receiver ground pin. Follow grounding best practices.
2	+5V	–	Connect to the 5 VDC power supply.
3	TMI	PPS	OEM719: Pin 19 OEM729: Pin 4 OEM7600: Pin 24 OEM7700: Pin 24 OEM7720: Pin 24
11	TTL_ TX	COMx_ RXD	Any COM port transmit and receive pair.  For most COM ports, a circuit to convert from 3.3V to 5V levels is required. The exception is COM1 on the OEM729. For COM1 on the OEM729, see <i>Direct connect COM1 on the OEM729 to the OEM-IMU-HG4930</i> below.
12	TTL_ RX	COMx_ TXD	

Enter the following commands on the OEM7 receiver to configure the receiver to use the direct connection to the OEM-IMU-HG4930 described in the previous table.

- CONNECTIMU COMx HG4930_ANxx



HG4930_ANxx can be HG4930_AN01, HG4930_AN04, or HG4930_AN04_400HZ depending on IMU variant and receiver model.

- PPSCONTROL ENABLE POSITIVE



For the location of the receiver ground pins and transmit and receive pairs, refer to the [OEM7 Installation and Operation User Manual](#).

Direct connect COM1 on the OEM729 to the OEM-IMU-HG4930



Pins not shown on the following table are not connected.

Table 11: COM1 on the OEM729 to OEM-IMU-HG4930 pin connections

HG4930		Receiver	
Pin	Pin name	Pin name	Description
1	GND	–	Connect to power supply Ground and any receiver ground pin. Follow grounding best practices.
2	+5V	–	Connect to the 5 VDC power supply.
3	TMI	PPS	OEM729: Pin 4
9	SER_DATA_OUT_H	COM1_RXD+	OEM729: Pin 18 Serial Data High Output (RS-485)
10	SER_DATA_OUT_L	COM1_RXD-	OEM729: Pin 15 Serial Data Low Output (RS-485)

Enter the following commands on the OEM7 receiver to configure the receiver to use the direct connection to the OEM-IMU-HG4930 described in the previous table.

1. `CONNECTIMU COM1 HG4930_ANxx`



HG4930_ANxx can be HG4930_AN01, HG4930_AN04, or HG4930_AN04_400HZ depending on IMU variant and receiver model.

2. `PPSCONTROL ENABLE POSITIVE`
3. `SETIMUPORTPROTOCOL RS422`



For the location of the receiver ground pins and transmit and receive pairs, refer to the [OEM7 Installation and Operation User Manual](#).

Direct connect a PwrPak7 to the OEM-IMU-HG4930



Pins not shown on the following table are not connected.

Table 12: PwrPak7 to OEM-IMU-HG4930 pin connections

HG4930		PwrPak7			Description
Pin	Pin name	DSUB HD26 pin	All I/O SPAN cable COM2 /IMU DB9 pin	Pin name	
1	DGND	17	5	COM2_GND	Connect to power supply Ground and any receiver ground pin. Follow grounding best practices.
2	+5VDC	–	–	–	Connect to the 5 VDC power supply.
3	TMI	16	1	EVENT_OUT1	PPS Synchronization signal
9	SER_DATA_OUT_H	20	2	COM2_422RX+	Serial Data High Output (RS-485)
10	SER_DATA_OUT_L	12	8	COM2_422RX-	Serial Data Low Output (RS-485)



For the location of the receiver ground pins and transmit and receive pairs, refer to the [PwrPak7 Installation and Operation User Manual](#).

Enter the following commands on the PwrPak7 to configure the receiver to use the direct connection to the OEM-IMU-HG4930 described in the previous table.

1. `CONNECTIMU COM2 HG4930_ANxx`



HG4930_ANxx can be HG4930_AN01, HG4930_AN04, or HG4930_AN04_400HZ depending on IMU variant and receiver model.

2. `SETIMUPORTPROTOCOL RS422`
3. `EVENTOUTCONTROL MARK1 ENABLE POSITIVE 100000000 900000000`

2.4.9 Connect an OEM-IMU- μ IMU-IC-UART directly to an OEM7 receiver

The OEM-IMU- μ IMU-IC-UART can connect directly to an OEM7 receiver using a serial port connection.

The OEM-IMU- μ IMU-IC-UART serial port uses RS-422 signal levels. Since most OEM7 receiver card ports use LVCMOS signal levels, an RS-422 line driver is needed to convert from LVCMOS to RS-422. The exception is COM1 on the OEM729 that operates at RS-232 or RS-422 levels.

The interface to the OEM-IMU- μ IMU-IC-UART must provide:

- a Micro-D 31 pin male connector

This connector mates with the connector on the OEM-IMU- μ IMU-IC-UART. See *Figure 7: OEM-IMU- μ IMU-IC-UART pinout* below.

- an RS-422 serial port connection to the OEM7 receiver

For most OEM7 receiver cards, the connection must include an RS-422 line driver.

If using COM1 on an OEM729, an RS-422 line driver is not required. However, the COM1 protocol must be set to RS-422 using the **SERIALPROTOCOL** command.

Use COM1 or COM2 on the PwrPak7 to connect to the OEM-IMU- μ IMU-IC-UART. These ports can be set to RS-422 protocol using the **SERIALPROTOCOL** command.

- a 5.0 VDC (± 0.5 VDC) regulated power supply

 Install a user supplied 2.5 A slow blow fuse to the positive pole of the power source to protect the power supply wiring and your warranty.

- a 3.3 V differential to single ended transceiver for the SYNC signal

Refer to *Table 13: OEM7 receiver card to OEM-IMU- μ IMU-IC-UART pin connections* below or *Table 14: OEM729 COM1 or PwrPak7 to OEM-IMU- μ IMU-IC-UART pin connections* on the next page for the connections required between the IMU and receiver.

Figure 7: OEM-IMU- μ IMU-IC-UART pinout

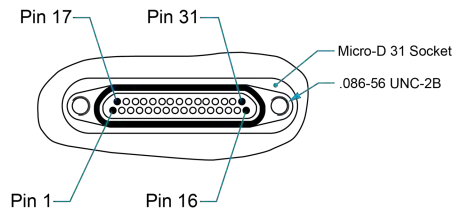

 Pins not shown on the following tables are not connected.

Table 13: OEM7 receiver card to OEM-IMU- μ IMU-IC-UART pin connections

μ IMU UART		RS-422 line driver		Receiver	
Pin	Pin name	Output	Input	Pin name	Description
1-2	GND	–	–	–	Any receiver ground pin
3	DATA_P	RS422 B+	–	–	Part of RS-422 transmit pair from the μ IMU UART
4	DATA_N	RS422 B-	–	–	Part of RS-422 transmit pair from the μ IMU UART
7-8	GND	–	–	–	Any receiver ground pin





μIMU UART		RS-422 line driver		Receiver	
Pin	Pin name	Output	Input	Pin name	Description
16	SYNCOUT_N	–	–	EVENT_IN2 OEM719: 7 OEM7600: 29 OEM7700: 29 OEM7720: 29	Part of the differential sync signal (ToV) pair from the μIMU UART.  The SYNCOUT_N and SYNCOUT_P are an RS-422 compatible differential pair and must be converted to a 3.3 V single ended signal before being input to EVENT_IN2.
17-19	5V Pwr	–	–	–	5 VDC power supply
20-22	GND	–	–	–	Connect to power supply Ground. Follow grounding best practices.
30	RESETIMUx	–	–	–	Recommended to connect to a “power good” signal from 5V power supply. May be left no connect if “power good” signal is unavailable.
31	SYNCOUT_P	–	–	EVENT_IN2 OEM719: 7 OEM7600: 29 OEM7700: 29 OEM7720: 29	Part of the differential sync signal (ToV) pair from the μIMU UART.  The SYNCOUT_N and SYNCOUT_P are an RS-422 compatible differential pair and must be converted to a 3.3 V single ended signal before being input to EVENT_IN2.
–	–	–	LVC MOS B IN	COMx_RXD	Any receiver COM port receive pin
–	–	–	GND		Any receiver ground pin

Table 14: OEM729 COM1 or PwrPak7 to OEM-IMU-μIMU-IC-UART pin connections

μIMU UART		Receiver		
Pin	Pin name	Pin	Pin name	Description
1-2	GND	–	–	Any receiver ground pin

μIMU UART		Receiver		
Pin	Pin name	Pin	Pin name	Description
3	DATA_P	OEM729 COM1: 18 PwrPak7 COM1: 3 COM2: 20	COMx_ RXD+	Part of RS-422 transmit pair from the OEM-IMU-μIMU UART
4	DATA_N	OEM729 COM1: 15 PwrPak7 COM1: 4 COM2: 12	COMx_ RXD-	Part of RS-422 transmit pair from the OEM-IMU-μIMU UART
7-8	GND	–	–	Any receiver ground pin
16	SYNCOUT_N	OEM729: 7 PwrPak7: 23	EVENT_ IN2	Part of the differential sync signal (ToV) pair from the OEM-IMU-μIMU UART.  The SYNCOUT_N and SYNCOUT_P are an RS-422 compatible differential pair and must be converted to a 3.3 V single ended signal before being input to EVENT_IN2.
17-19	5V Pwr	–	–	5 VDC power supply
20-22	GND	–	–	Connect to power supply Ground. Follow grounding best practices.
30	RESETIMUx	–	–	Recommended to connect to a “power good” signal from 5V power supply. May be left no connect if “power good” signal is unavailable.
31	SYNCOUT_P	OEM729: 7 PwrPak7: 23	EVENT_ IN2	Part of the differential sync signal (ToV) pair from the OEM-IMU-μIMU UART.  The SYNCOUT_N and SYNCOUT_P are an RS-422 compatible differential pair and must be converted to a 3.3 V single ended signal before being input to EVENT_IN2.



For the location of the receiver ground pins and transmit and receive pairs, refer to the [OEM7 Installation and Operation User Manual](#) or [PwrPak7 Installation and Operation User Manual](#).

2.4.10 IMU-KVH1750 and IMU-P1750 baud rate conversion

If purchased directly from KVH, an IMU-KVH1750 or IMU-P1750 IMU must be configured before it can be used with an OEM7 receiver.

The IMU-KVH1750 and IMU-P1750 natively communicate at 921,600 bps, however the maximum baud rate of the COM ports on an OEM7 receiver is 460,800 bps. Thus, IMU-KVH1750 and IMU-P1750 IMUs purchased from KVH must be modified to use 460,800 bps. Also, the MSYNC setting on the IMU-KVH1750 or IMU-P1750 must be set to EXT.



Though slower, 460,800 bps is more than adequate to transmit the data at the required 200 Hz without any impact to performance.

There are two methods to change the IMU-KVH1750 or IMU-P1750 IMU baud rate. If an OEM6 receiver is available, a command is available that will allow the receiver to change the IMU baud rate. If not, a direct RS-422 connection at 921,600 baud is required to change the IMU baud rate.

Connect directly to the IMU



This method requires a direct connection to the IMU at 921,600 baud over RS-422. Make sure the RS-422 link used is capable of 921,600 baud as not all serial ports are capable of that rate.

1. Open a command terminal at 921,600 baud via an RS-422 serial link.
By default, the IMU will output 0.5 Hz binary messages which will help confirm you are connected properly.
2. Issue the following commands in sequence to enter configuration mode and change the baud rate.

```
=CONFIG,1
=MSYNC,EXT
=BAUD,460800
```
3. Upon completion of these commands, power cycle the IMU to boot up in the new baud rate.
4. Confirm the change by connecting to the IMU at 460,800 baud and verifying the incoming messages.

The new baud rate configuration is saved to the IMU NVM automatically so the process is complete and the IMU is ready for use with an OEM7 receiver.

Use an OEM6 receiver command

OEM6 firmware as of version OEM060631RN0000 (Dec 2016) includes the **IMUCONFIGURATION** command that internally configures the IMU-KVH1750 or IMU-P1750 IMU for SPAN communication. Three sets of configuration options are available, two of which allow changing the baud rate of the IMU to either 921,600 or 460,800. This provides customers upgrading to OEM7 an easy method to modify the baud rate. To change the IMU to 460800 baud, use the following procedure:

1. Connect the IMU to an RS-422 capable OEM6 receiver communication port.
2. Issue the following command.

```
CONNECTIMU COM# IMU_KVH_1750
```

3. Issue the following command.

```
IMUCONFIGURATION IMU_KVH_1750 2
```

The **IMUCONFIGURATION** command can be used to configure an IMU-KVH1750 or IMU-P1750 IMU depending on the value of the Option field.

```
IMUCONFIGURATION IMUType [Option]
```

IMU type	Option	Configuration details
IMU_KVH_1750	0	Configure KVH options for NovAtel communication.
	1	Change KVH baud rate to 921,600
	2	Change KVH baud rate to 460,800

2.5 Connect the IMU to the PwrPak7

Connect the IMU to the COM1 or COM2 serial port on the PwrPak7. Both of these serial ports are available on the HD26 COM PORTS connector on the PwrPak7.

IMU-CPT, IMU-KVH1750, IMU-P1750, IMU-FSAS and OEM-IMU-STIM300D

These IMUs require an additional output or input from the HD26 COM PORTS connector on the PwrPak7 to synchronize the IMU and receiver. See *Table 15: Additional IMU to PwrPak7 connections* on the next page.



If using an IMU-KVH1750 or IMU-P1750 not purchased through NovAtel, the baud rate of the IMU must be changed to 460,800 bps and the output method changed to MSYNC,EXT. For information about changing the IMU baud rate, see *IMU-KVH1750 and IMU-P1750 baud rate conversion* on the previous page.

2.5.1 NovAtel IMU interface cables

An interface cable is available from NovAtel for each IMU supported by OEM7 receivers. The interface cables provide access to the IMU power and communication signals. For information about these cables, refer to the applicable IMU in the *IMU technical specifications* on page 144.

2.5.2 PwrPak7 cables

The following communication cable is available from NovAtel for connecting an IMU to the PwrPak7.

- PwrPak7 IMU cable (01019767)

This cable connects the PwrPak7 to an IMU in an IMU Enclosure (IMU-ISA-100C, IMU-LN200, IMU-LN200C, IMU-HG1900 or IMU-μIMU-IC) using the COM1 serial port.

This cable is applicable to SPAN systems with an IMU in the IMU Enclosure that do not require the EVENT inputs, EVENT outputs, PPS output or the other serial COM ports.

- PwrPak7 All I/O SPAN cable (01020004)

This cable provides access to all of the signals available on the PwrPak7 26 pin D-SUB connector. Use the COM2 connector on this cable to connect the NovAtel IMU Interface cables. This connector includes the COM2 serial port signals and the additional signal required by the IMU-CPT, IMU-KVH1750, IMU-P1750, and IMU-FSAS.

2.5.3 Custom IMU interface cable requirements

The HD26 COM PORTS connector provides access to three serial COM ports, three EVENT inputs, three EVENT outputs, the wheel sensor input and PPS output. When selecting or building the cabling for the PwrPak7, make sure all of the required input and output signals are accounted for in the HD26 COM PORTS connector cabling design.

For information about the DB26 COM PORTS pinout, refer to the [PwrPak7 Installation and Operation User Manual](#).

For information about the IMU port pinout, refer to refer to the applicable IMU in the *IMU technical specifications* on page 144.

Some IMUs require an additional signal from the receiver to synchronize the receiver and IMU.

Table 15: Additional IMU to PwrPak7 connections

IMU	IMU connector		PwrPak7 DB26 COM ports	
	Signal name	Pin	Signal name	Pin
IMU-CPT	External Clock Input	36	EVENT_OUT1	16
IMU-KVH1750 IMU-P1750	MSync	11	EVENT_OUT1	16
IMU-FSAS	DAS(+)	7	EVENT_OUT1	16
OEM-IMU-STIM300D	Time of Validity	4	EVENT_IN2	23

2.5.4 Connect an OEM IMU to a PwrPak7 using a direct connection

Some OEM IMUs can communicate with the PwrPak7 with out using an interface card. For information about using a direct connection, see:

- *Connect an OEM-IMU-STIM300 directly to an OEM7 receiver on page 45*
- *Connect an OEM-IMU-HG4930 directly to an OEM7 receiver on page 48*
- *Connect an OEM-IMU- μ IMU-IC-UART directly to an OEM7 receiver on page 52*

2.6 Connect power



If you are using a MEMS OEM IMU (OEM-IMU-ADIS-16488, OEM-HG1900, OEM-HG1930, OEM-IMU-STIM300) and a MIC, see *MIC installation* on page 61 for information about connecting and powering the MIC and IMU.



If you are using an OEM IMU (OEM-IMU-ISA-100C, OEM-HG1900, OEM-LN200 or OEM-IMU- μ IMU-IC) and a UIC, see *UIC installation* on page 71 for information about connecting and powering the UIC and IMU.

2.6.1 Receiver power

For information about connecting power to an OEM7 receiver card, see the [OEM7 Installation and Operation User Manual](#).

For information about connecting power to a PwrPak7, see the [PwrPak7 Installation and Operation User Manual](#).

2.6.2 IMU power

In addition to the receiver power supply, a power supply is needed for the IMU. See *Table 16: IMU power supply* below for the voltage requirements for each IMU. The same power supply can be used for the receiver and the IMU, if the power supply meets the power requirements of both devices.

Table 16: IMU power supply

IMU	Power requirement	Recommended fuse
IMU-CPT	+9 to +18 VDC	2.0 A slow blow
IMU-FSAS	+10 to +34 VDC	2.0 A slow blow
IMU-HG1900	+10 to +34 VDC	1.8 A slow blow
IMU-IGM-A1	+10 to +30 VDC	0.5 A slow blow
IMU-IGM-S1	+10 to +30 VDC	1.0 A slow blow
IMU-ISA-100C	+10 to +34 VDC	2.5 A slow blow
IMU-KVH1750	+9 to +36 VDC	1.25 A slow blow
IMU-P1750	+9 to +36 VDC	1.25 A slow blow
IMU-LN200 IMU-LN200C	+10 to +34 VDC	2.5 A slow blow
IMU- μ IMU-IC	+10 to +34 VDC	1.8 A slow blow
UIMU-HG1700-AG58 UIMU-HG1700-AG62	+12 to +28 VDC	1.8 A slow blow
UIMU-LN200	+12 to +28 VDC	1.8 A slow blow
OEM-IMU-ADIS-16488 (direct connection)	+3.3 VDC	0.5 A slow blow
OEM-IMU-EG320N (direct connection)	+3.3 VDC	0.25 A slow blow
OEM-IMU-EG370N (direct connection)	+3.3 VDC	0.25 A slow blow
OEM-IMU-HG4930 (direct connection)	+5.0 VDC	1.6 A slow blow
OEM-IMU-STIM300 (direct connection)	+5.0 VDC	0.63 A slow blow
OEM-IMU- μ IMU-IC-UART (direct connection)	+5.0 VDC	2.5 A slow blow

For most IMUs, connect the power leads on the IMU interface cable to the IMU power supply.
For an IMU in the IMU Enclosure (IMU-HG1900, IMU-ISA-100C, IMU-LN200 or IMU- μ IMU-IC), connect the IMU Power Cable (NovAtel part # 60723136) from the IMU to the IMU power supply.



The IMU Power Cable has four power leads, two positive (VIN+) and two negative (VIN-). Typically, all four wires are connected to the power supply. However, the IMU Enclosure can be powered from a single pair (VIN+ and VIN-). This is beneficial in systems with a backup power supply as one pair can be connected to the main power supply and the second pair can be connected to the backup power supply.

When connecting all four wires, ensure both positive lines pass through a single appropriately rated fuse. For the backup power configuration, both positive lines need an appropriately rated fuse.

Details about the IMU ports and cables can be found in *IMU technical specifications* on page 144.

2.7 MIC installation

For an IMU that cannot communicate directly to a NovAtel OEM7 receiver (see *Connect the IMU to the OEM7 receiver card* on page 38), an interface card is required for communication. The MEMS Interface Card (MIC) provides this communication between an OEM7 receiver card and the IMU.



A MIC is required to connect the following IMUs with an OEM7 receiver: HG1700, OEM-HG1900 and OEM-HG1930. For other IMUs that require an interface card (e.g. OEM-IMU-ISA-100C, LN200 or OEM-IMU- μ IMU-IC), the Universal Interface Controller (UIC) is required to handle the additional power requirements. See *UIC installation* on page 71.

There are two MIC configurations: stack up and standalone. In a stack up configuration, the MIC card is mounted on an OEM719 receiver. In a standalone configuration, the MIC is mounted separately from the receiver.



The MIC supports all OEM7 receiver cards for communications. The OEM719 is the only OEM7 receiver card that can be directly integrated and powered by the MIC.

2.7.1 Install a MIC in a stack up configuration

In a stack up configuration, the MIC is connected to an OEM719 receiver using the 20-pin header on the OEM719. Power and communications connections to the receiver are made through the MIC.



The OEM719 is the only OEM7 receiver card that can be installed in a stack up configuration. For other OEM7 receiver cards, see *Install a MIC in a standalone configuration* on page 64.



Important!

Assemble in accordance with applicable industry standards. Ensure all Electrostatic Discharge (ESD) measures are in place, in particular, use a ground strap before exposing or handling any electronic items, including the MIC, receiver and IMU. Take care to prevent damaging or marring painted surfaces, O-rings, sealing surfaces and the IMU.

For more information about ESD practices, see the [OEM7 Installation and Operation User Manual](#).

Figure 8: Basic set up – MIC in stack up configuration

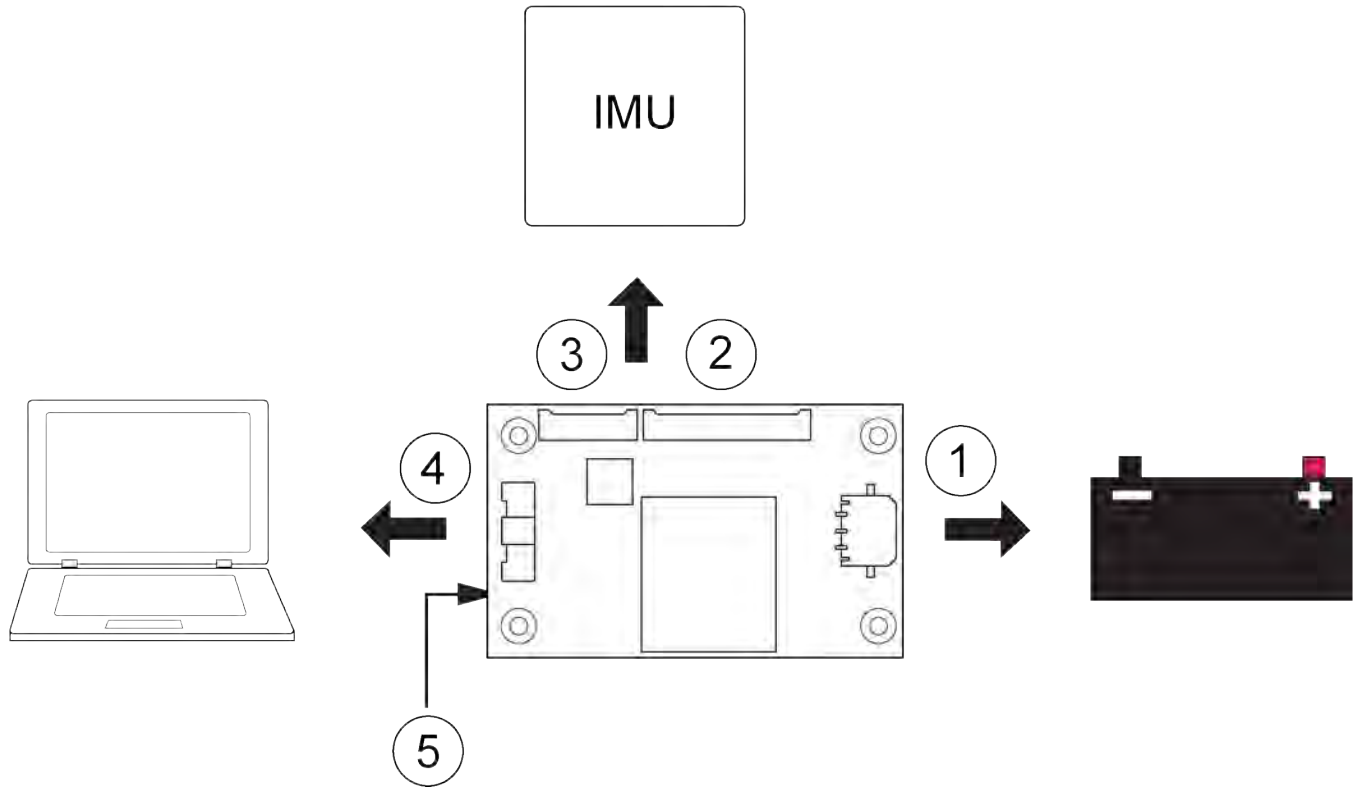

Ref	Connector	Part number	Mating connector	Description
1	P101	43650-0313 (Molex)	43645-0300 (Molex)	Connects to the MIC power supply. This connection provides power to the MIC and the OEM719 receiver. (user supplied cable)
2	P601	53780-2070 (Molex)	51146-2000 (Molex)	Connects to HG1700, OEM-HG1900, OEM-HG1930 and OEM-IMU-STIM300 IMUs. (NovAtel supplied cable kit)
3	P701	53780-1070 (Molex)	51146-1000 (Molex)	Connects to OEM-IMU-ADIS-16488 IMUs. (NovAtel supplied cable kit)
4	P301	501571-3007 (Molex)	501189-3010 (Molex)	Connects the MIC and OEM719 communication signals to the user system. (user supplied cable)
5	J301	ASP-163577-01 (Samtec)	N/A	Connects to the main connector (P1701) on an OEM719 receiver. J301 is on the bottom of the MIC card



For information about the MIC connectors and pin-outs, see *MIC connectors* on page 281.



For information about the OEM7 receiver card connectors and pinouts, refer to the [OEM7 Installation and Operation User Manual](#).

Use the following steps to install the OEM719 receiver and MIC:

1. Mount the components of the SPAN system. See *Mount the SPAN system components* below.
2. Connect the IMU to the MIC. See *Connect the IMU to the MIC* on page 67.
3. Connect power to the MIC. See *Connect power to the MIC and OEM7 receiver* on page 69.
4. Connect the input and output signals to the MIC. See *Connect the input and output signals* on page 70.

Mount the SPAN system components

1. Mount the antenna.

Refer to the [OEM7 Installation and Operation User Manual](#) for information about mounting a GNSS antenna.

2. Use the standoffs supplied with the MIC card to secure the OEM719 to its mounting location.

See *Figure 9: Mount the MIC on the OEM719* on the next page.

See the [OEM7 Installation and Operation User Manual](#) for information about installing an OEM7 receiver.



The part number for the recommended standoffs is RAF-M21073005AL7 (Irwin Industrial).

If alternate standoffs are selected, use equivalent parts with a minimum height of 12 mm.



Ensure all standoffs are properly installed and the mounting location is flat. The amount of board deflection (bow and twist) must not exceed 0.75%. For example, on the MIC which is 75 mm long and 46 mm wide, the deflection along the length must not exceed 0.56 mm and the deflection along the width must not exceed 0.34 mm.



Ensure the MIC is mounted close enough to the IMU so the interface cable can reach both devices.

3. Connect the antenna cable to the antenna jack on the OEM719.

The antenna cable must have a right angle MCX connector on the end that connects to the OEM719.



Warning! Do not apply power to the cards until the antenna cable is attached.



The part number for the recommended MCX connector is M1051-110 (ShinA Telecom). If an alternate part is used, it should meet the dimensions shown in the diagram.

The space between the OEM719 and the MIC is limited. The height of the MCX connector must not exceed 8.65 mm.

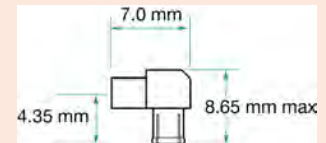

4. Align the mating connector (J301) on the MIC with the 20-pin header (P1701) on the OEM719. Make sure all of the pins on the header are aligned with the holes in the mating connector. Press down on the MIC to seat the connector on the header.
5. Use the four screws supplied with MIC to secure the MIC card to the OEM719.

Figure 9: Mount the MIC on the OEM719

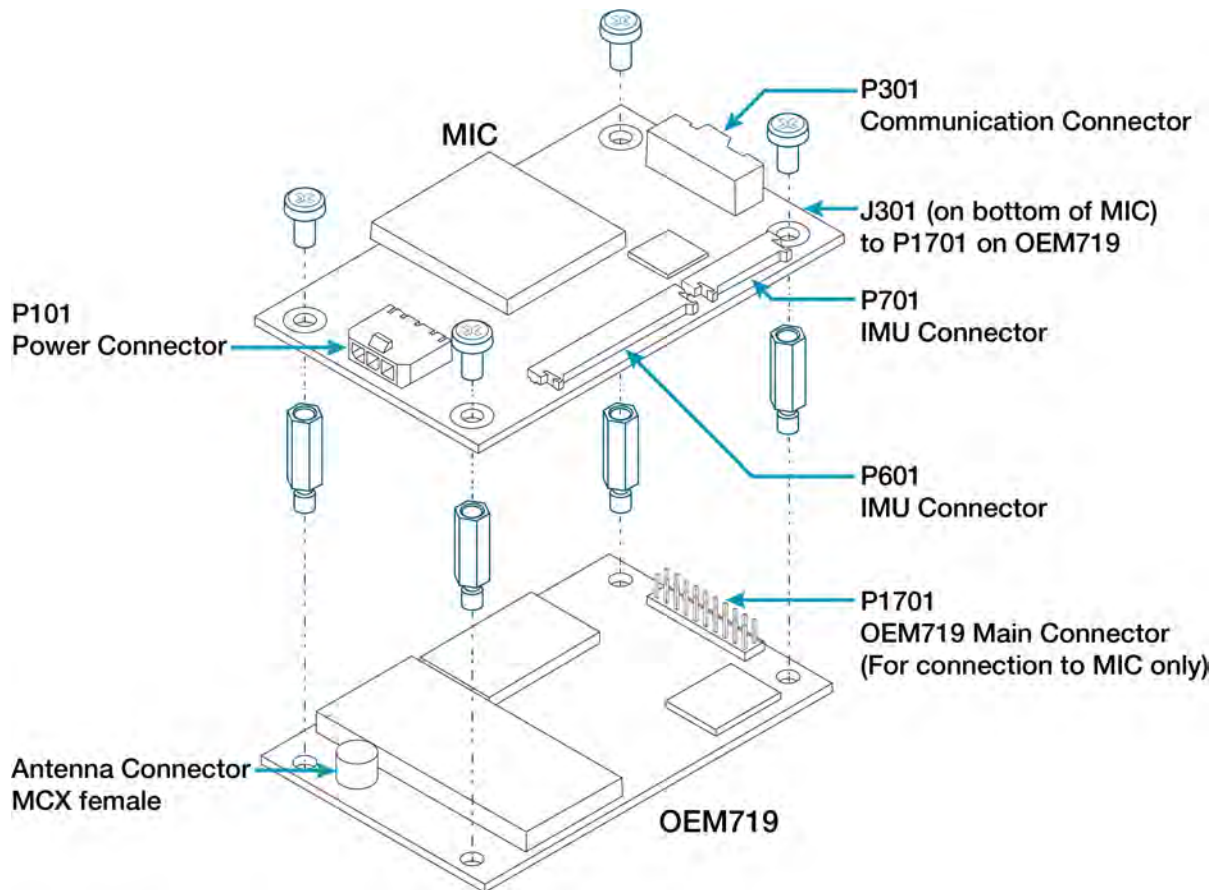

2.7.2 Install a MIC in a standalone configuration

In a standalone configuration, the MIC is mounted separately from the OEM7 receiver.



Important! Assemble in accordance with applicable industry standards. Ensure all Electrostatic Discharge (ESD) measures are in place, in particular, use a ground strap before exposing or handling any electronic items, including the MIC, receiver and IMU. Take care to prevent damaging or marring painted surfaces, O-rings, sealing surfaces and the IMU.

For more information about ESD practices, see the [OEM7 Installation and Operation User Manual](#).

Figure 10: Basic MIC set up

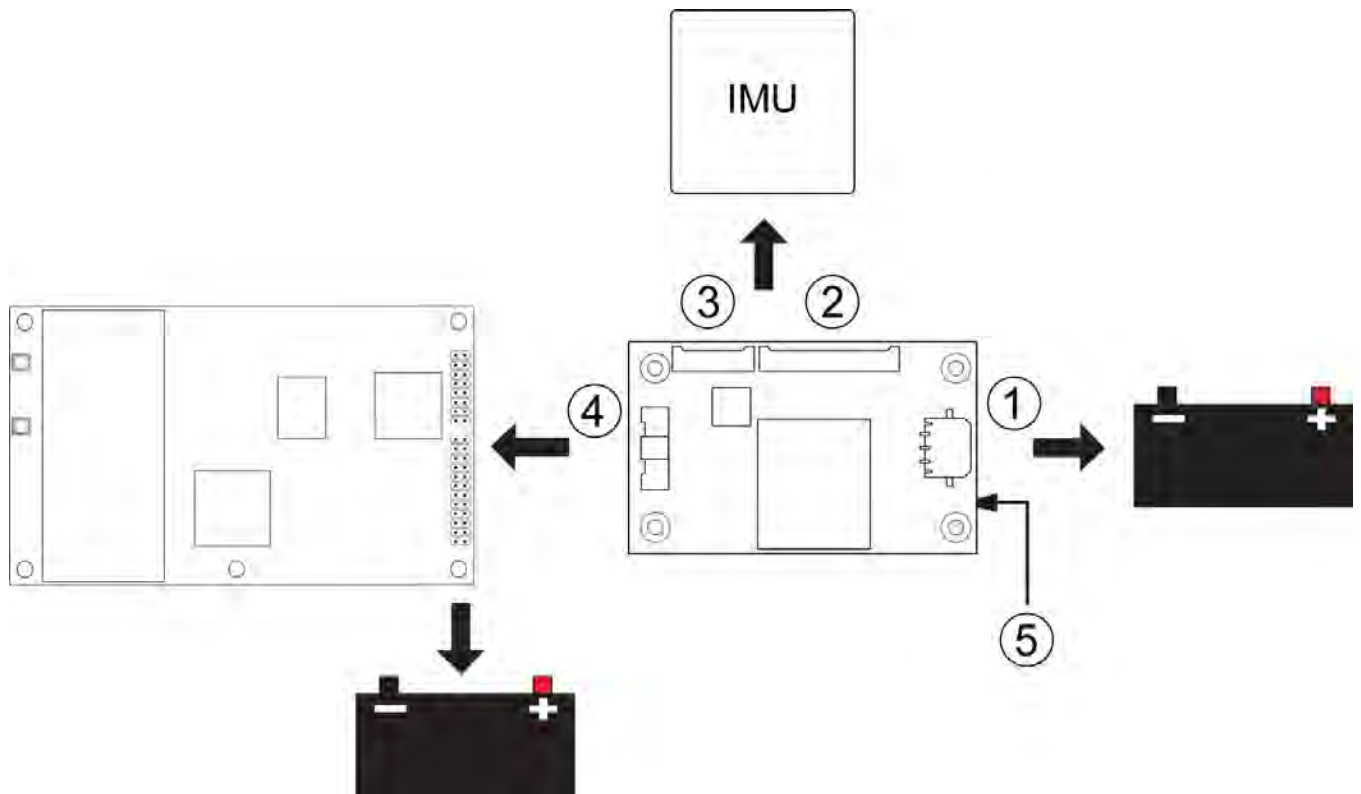

Ref	Connector	Part number	Mating connector	Description
1	P101	43650-0313 (Molex)	43645-0300 (Molex)	Connects to the MIC power supply. (user supplied cable)
2	P601	53780-2070 (Molex)	51146-2000 (Molex)	Connects to HG1700, OEM-HG1900, OEM-HG1930 and OEM-IMU-STIM300 IMUs. (NovAtel supplied cable)
3	P701	53780-1070 (Molex)	51146-1000 (Molex)	Connects to OEM-IMU-ADIS-16488 IMUs. (NovAtel supplied cable)
4	P301	501571-3007 (Molex)	501189-3010 (Molex)	Connects the MIC serial port to the OEM7 receiver. (user supplied cable)
5	J301	ASP-163577-01 (Samtec)	N/A	This connector is not used.



For information about the MIC connectors and pin-outs, see *MIC connectors* on page 281.



For information about the OEM7 receiver card connectors and pinouts, refer to the [OEM7 Installation and Operation User Manual](#).



OEM729 recommendations

- Use COM1 for connection to a computer. COM1 uses RS-232 levels and can be connected to a computer without additional interface circuitry.
- Use COM2 for connection to the MIC serial port. Both the MIC serial port and COM2 use LVCMOS levels and can be connected without additional interface circuitry.

Use the following steps to install the OEM7 receiver and MIC:

1. Mount the components of the SPAN system. See *Mount the SPAN system components* below.
2. Connect the IMU to the MIC. See *Connect the IMU to the MIC* on the next page.
3. Connect the MIC to the OEM7 receiver. See *Connect the MIC to a receiver* on the next page.
4. Connect power to the MIC and OEM7 receiver. See *Connect power to the MIC and OEM7 receiver* on page 69.

Mount the SPAN system components

1. Mount the antenna.

Refer to the [OEM7 Installation and Operation User Manual](#) for information about mounting a GNSS antenna.

2. Mount the OEM7 receiver.

See the [OEM7 Installation and Operation User Manual](#) for information about installing an OEM7 receiver.

3. Install the MIC in a secure enclosure to reduce environmental exposure and RF interference. If there is sufficient space, the MIC can reside in the same enclosure as the receiver.

Use the screws supplied with the MIC card to secure the MIC to its mounting location. See *MIC mechanical drawings* on page 278 for the MIC dimensions.



Ensure the MIC is mounted close enough to the IMU so the interface cable can reach both devices.



Ensure all standoffs are properly installed and the mounting location is flat. The amount of board deflection (bow and twist) must not exceed 0.75%. For example, on the MIC which is 75 mm long and 46 mm wide, the deflection along the length must not exceed 0.56 mm and the deflection along the width must not exceed 0.34 mm.

4. Mount the IMU.

See *Mount the IMU* on page 36.

Connect the MIC to a receiver

1. Using a customer supplied wiring harness, connect the MIC serial port to a serial port on the OEM7 receiver. The MIC serial port is available on the communications connector (P301) of the MIC.

See *MIC connectors* on page 281 for the pinouts of the communications connector. See the [OEM7 Installation and Operation User Manual](#) for information about connecting a serial port to the receiver.

All signal I/O on the MIC, with the exception of the USB port, are at LVCMOS levels.

To connect the MIC to devices that use other signals levels, such as a computer with an RS-232 serial port, an interface circuit that converts LVCMOS to the other signal level must be used.

Table 17: COM port recommendations

OEM719 OEM7600 OEM7700 OEM7720	All of the COM ports on these receivers use LVCMOS levels and are signal level compatible with the MIC serial port.
OEM729	Use COM2 or COM3 of the OEM729 receiver to connect the MIC serial port. These COM ports use LVCMOS levels and are signal level compatible with the MIC serial port. COM1 on the OEM729 receiver can use RS-232 levels (default) or RS-422 levels and is not signal level compatible with the MIC serial port.



For information about the OEM7 receiver card connectors and pinouts, refer to the [OEM7 Installation and Operation User Manual](#).

2. Connect a computer (for monitoring and configuration) to the OEM7 receiver. Refer to the [OEM7 Installation and Operation User Manual](#) for information about connecting data communications equipment to an OEM7 receiver.

2.7.3 Connect the IMU to the MIC

1. Attach the IMU mounting Printed Circuit Board (PCB) to the IMU. Ensure all the pins on the header are aligned with the holes on the mating connector.



An IMU mounting PCB is not used with the OEM-IMU-STIM300 IMU.

2. Connect the IMU-to-MIC interface cable to the IMU.
3. Connect the IMU-to-MIC interface cable to the IMU connector on the MIC.

- Use the 10 pin locking connector (P701) for an OEM-IMU-ADIS-16488 IMU.
See *Figure 13: Connect the OEM-IMU-ADIS-16488 IMU to the MIC (OEM Cable Kit: 01019007)* on the next page.
- Use the 20 pin locking connector (P601) for an HG1700, OEM-HG1900, OEM-HG1930 or OEM-IMU-STIM300 IMU.
See *Figure 11: Connect the OEM-HG1900 IMU to the MIC (OEM Cable Kit: 01018871)* below, *Figure 12: Connect the OEM-HG1930 IMU to the MIC (OEM Cable Kit: 01018869)* below or *Figure 14: Connect the OEM-IMU-STIM300 IMU to the MIC (OEM Cable Kit: 01019174)* on the next page.

Figure 11: Connect the OEM-HG1900 IMU to the MIC (OEM Cable Kit: 01018871)

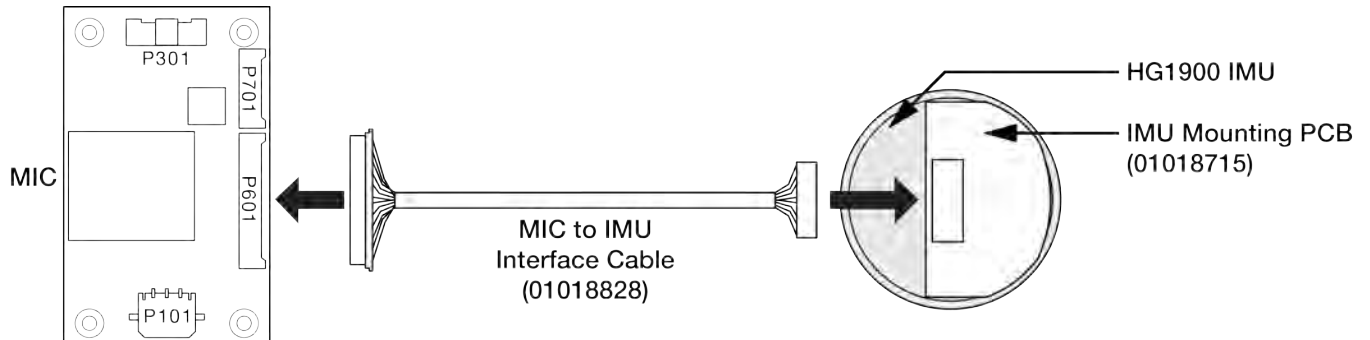
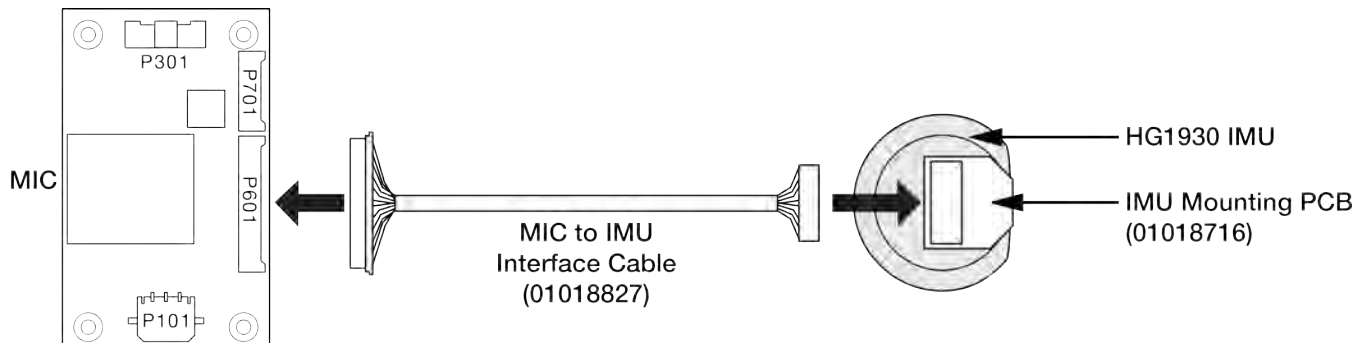
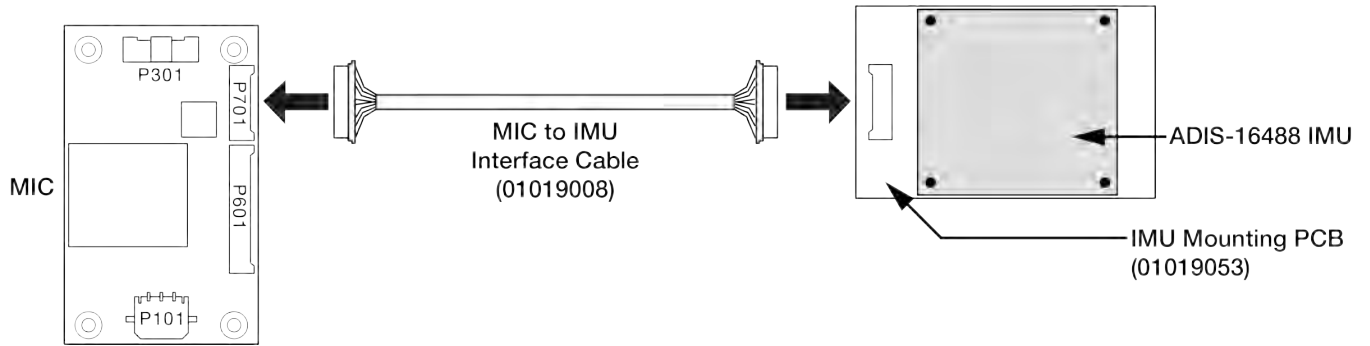
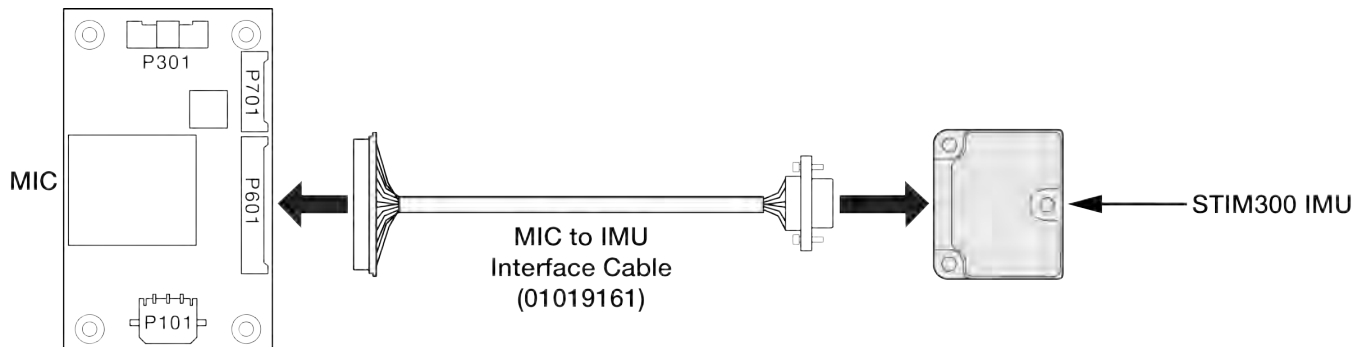

Figure 12: Connect the OEM-HG1930 IMU to the MIC (OEM Cable Kit: 01018869)



The OEM-IMU-ADIS-16488 and OEM-IMU-STIM300 are capable of a direct connection with OEM7 receivers, when a proper connection is available (OEM-IMU-ADIS-16488 = SPI, OEM-IMU-STIM300 = serial RS-422). If using the MIC connection is necessary, the following diagrams detail the cable connection parts between the MIC and IMU.

Figure 13: Connect the OEM-IMU-ADIS-16488 IMU to the MIC (OEM Cable Kit: 01019007)**Figure 14: Connect the OEM-IMU-STIM300 IMU to the MIC (OEM Cable Kit: 01019174)**

2.7.4 Connect power to the MIC and OEM7 receiver

Stack up configuration



In a stack up configuration, the power connection to the MIC provides power to the MIC, the OEM719 and the IMU.

1. Connect a +10 to +30 VDC power supply to the power connector (P101) on the MIC. See *MIC connectors* on page 281 for pinout information for the power connector.

Standalone configuration



In a standalone configuration, a separate power supply is required for the OEM7 receiver. For information about the power supply requirements, refer to the Technical Specifications appendix for the receiver card in the [OEM7 Installation and Operation User Manual](#).

1. Using a customer supplied wiring harness, connect a +10 to +30 VDC power supply to the power connector (P101) on the MIC.
See *MIC connectors* on page 281 for pinout information for the power connector.
2. Using a customer supplied wiring harness, connect power to the OEM7 receiver. See the [OEM7 Installation and Operation User Manual](#) for information about connecting power to the receiver.

2.7.5 Connect the input and output signals

Access to the communication and strobe signals varies depending on how the MIC is connected to the receiver.

Standalone configuration

In a standalone configuration, the communication connections to the receiver are available on the OEM7 receiver.

Stack up configuration

In a stack up configuration, all of the communication connections to the MIC and the OEM719 receiver are available on the communications connector (P601) on the MIC. These connections include:

- MIC serial port
- OEM719 serial port (COM2)
- USB port
- Event1 trigger input
- Event2 trigger input
- 1 PPS (Pulse Per Second) output
- VARF (Variable Frequency) output
- Reset input
- Position Valid output

See *MIC connectors* on page 281 for the pinouts of the communications connector.



All signal I/O with the exception of the USB port are at LVCMOS levels. To connect the MIC to devices that use other signals levels, such as a computer with an RS-232 serial port, an interface circuit that converts LVCMOS to the other signal level must be used.



Use a twisted pair for the USB port connection and keep the wires as short as possible.

2.8 UIC installation

For an IMU that cannot communicate directly to a NovAtel OEM7 receiver (e.g. SDLC/HDLC), an interface card is required for communication. The Universal Interface Controller (UIC) provides this communication between an OEM7 receiver card and the IMU, specifically an IMU that has higher power requirements.



Use a UIC to connect the following IMUs to an OEM7 receiver: OEM-IMU-ISA-100C, LN200(C) and OEM-IMU- μ IMU-IC. For other IMUs that require an interface card and have lower power requirements (e.g. HG1700, OEM-HG1900 and OEM-HG1930) a MEMS Interface Card (MIC) can be used. See *MIC installation* on page 61.

Figure 15: Basic UIC installation

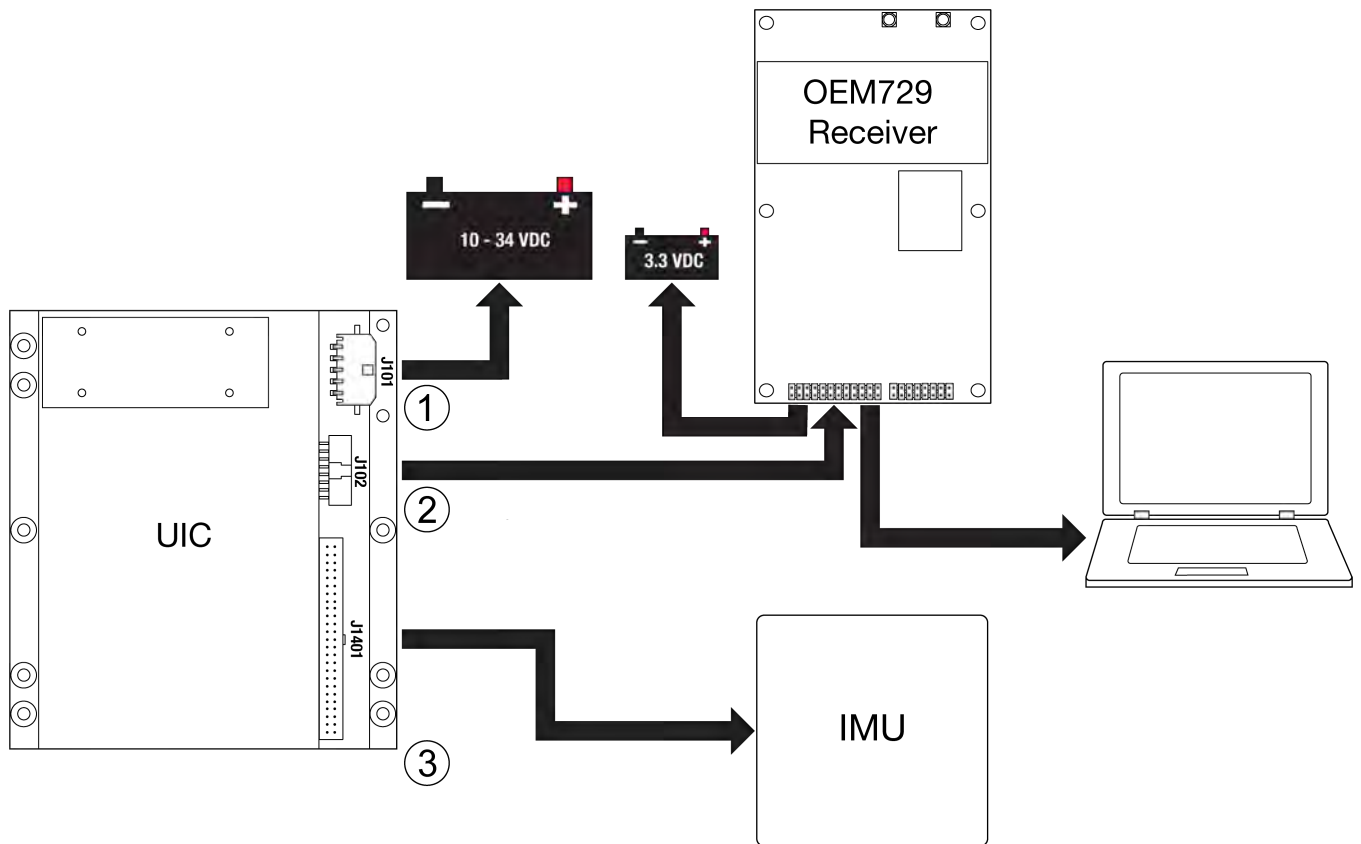

Ref	Connector	Part number	Mating connector	Description
1	J101	43650-0513 (Molex)	43645-0500 (Molex)	Connects to the UIC power supply (user supplied cable)
2	J102	98464-G61-16LF (FCI)	90311-016LF (FCI)	Connects the UIC serial port to the OEM7 receiver (user supplied cable)
3	J1401	LTMM-125-02-L-D (Samtec)	SQT-125-01-L-D (Samtec)	Connects to the IMU (NovAtel supplied cable)



For information about the UIC connectors and pinouts, see *UIC connectors* on page 295.



For information about the OEM7 receiver card connectors and pinouts, refer to the [OEM7 Installation and Operation User Manual](#).



Important! Assemble in accordance with applicable industry standards. Ensure all Electrostatic Discharge (ESD) measures are in place, in particular, use a ground strap before exposing or handling any electronic items, including the UIC, receiver and IMU. Take care to prevent damaging or marring painted surfaces, O-rings, sealing surfaces and the IMU. For more information about ESD practices, see the [OEM7 Installation and Operation User Manual](#).

Use the following steps to install the OEM7 receiver and UIC:

1. Mount the components of the SPAN system. See *Mount the SPAN system components* below.
2. Connect the IMU to the UIC. See *Connect the IMU to the UIC* on the next page.
3. Connect the UIC to the OEM7 receiver. See *Connect the UIC to a receiver* on the next page.
4. Connect power to the UIC and OEM7 receiver. See *Connect power to the UIC and OEM7 receiver* on page 74.

2.8.1 Mount the SPAN system components

1. Mount the antenna.

Refer to the [OEM7 Installation and Operation User Manual](#) for information about mounting a GNSS antenna.

2. Mount OEM7 receiver.

See the [OEM7 Installation and Operation User Manual](#) for information about installing an OEM7 receiver.

3. Mount the IMU.



See *Mount the IMU* on page 36.

4. Install the UIC in a secure enclosure to reduce environmental exposure and RF interference. If there is sufficient space, the UIC can reside in the same enclosure as the receiver.

Use M3 pan head stainless steel screws to secure the UIC to its mounting location. See *UIC mechanical drawings* on page 291 for the UIC dimensions.



Ensure the UIC is mounted close enough to the IMU so the interface cable can reach both devices. For the length of the interface cable, refer to the specifications for the IMU in *IMU technical specifications* on page 144.

-  **Ensure the mounting location provides at least 5 mm of clearance below the board to allow for components on the bottom of the UIC.**
-  **Ensure all standoffs are properly installed and the mounting location is flat. The amount of board deflection (bow and twist) must not exceed 0.75%. For example, on the UIC which is 100 mm long and 113 mm wide, the deflection along the length must not exceed 0.75 mm and the deflection along the width must not exceed 0.85 mm.**

2.8.2 Connect the IMU to the UIC

1. If using an OEM-IMU-ISA-100C, attach the screw kit to the *IMU to UIC Interface Cable*.
2. Connect the *IMU to UIC Interface Cable* supplied with the UIC to the IMU. For IMU cables with screws, secure the cable to the IMU using the screws.
3. Connect the *IMU to UIC Interface Cable* to the IMU connector (J1401) on the UIC.

2.8.3 Connect the UIC to a receiver

1. Using a customer supplied wiring harness, connect the UIC serial port to a serial port on the OEM7 receiver. See *UIC connectors* on page 295 for pinout information for the communications connector (J102).

 **The serial port on the UIC uses RS-422 levels.**

To connect the UIC to devices that use other signals levels, such as an LVCMOS COM port on the OEM7 receiver, an interface circuit that converts to and from RS-422 must be used.

Table 18: COM port recommendations

OEM719 OEM7600 OEM7700 OEM7720	All of the COM ports on these receivers use LVCMOS levels. An interface circuit that converts to and from RS-422 levels is required for the port connected to the UIC.
OEM729	COM1 on the OEM729 receiver can use RS-232 (default) or RS-422 levels. To use COM1 for connection to the UIC, configure the COM1 port to use RS-422 levels. Refer to the OEM7 Installation and Operation User Manual for information about changing COM1 to RS-422 levels. COM2 and COM3 on the OEM729 receiver use LVCMOS levels. To use COM2 or COM3 for connection to the UIC serial port, an interface circuit that converts to and from RS-422 levels is required.

PwrPak7

COM1 and COM2 on the PwrPak7 can use RS-232 levels (default) or RS-422 levels. To use COM1 or COM2 for connection to the UIC, use the **SERIALPROTOCOL** command to configure the COM1 or COM2 port to use RS-422 levels.

COM3 on the PwrPak7 uses RS-232 levels. To use COM3 for connection to the UIC serial port, an interface circuit that converts to and from RS-422 levels is required.



For information about the OEM7 receiver card connectors and pinouts, refer to the [OEM7 Installation and Operation User Manual](#).

2. Connect a computer (for monitoring and configuration) to the OEM7 receiver. Refer to the [OEM7 Installation and Operation User Manual](#) for information about connecting data communications equipment to an OEM7 receiver.

2.8.4 Connect power to the UIC and OEM7 receiver

A separate power supply is required for the OEM7 receiver. For information about the power supply requirements, refer to the Technical Specifications appendix for the receiver card in the [OEM7 Installation and Operation User Manual](#).

1. Using a customer supplied wiring harness, connect a +10 to +34 VDC power supply to the power connector (J101) on the UIC. See *UIC connectors* on page 295 for pinout information for the power connector.
2. Using a customer supplied wiring harness, connect power to the OEM7 receiver. See the [OEM7 Installation and Operation User Manual](#) for information about connecting power to the receiver.

2.8.5 UIC Status LEDs

The LEDs on the UIC provide basic status information.

Figure 16: UIC Status LEDs

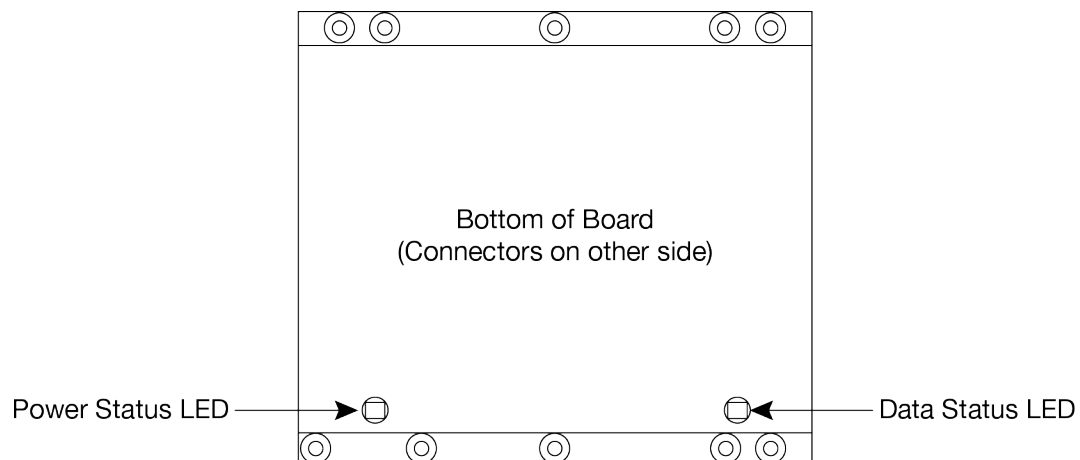

Table 19: UIC Status LEDs

LED	Off	On (red)	On (green)	Flash slow (yellow, 1 Hz)	Flash fast (yellow, 3 Hz)
Power	No power to UIC.	An error occurred during boot up or initialization.	UIC is powered on with no errors detected during boot up or initialization.	Boot up and IMU initialization.	N/A
Data	No communication between UIC and GNSS receiver.	N/A	UIC is transmitting and receiving data without errors.	UIC is receiving data from the receiver, but not transmitting data.	UIC is transmitting data to the receiver, but not receiving data.



2.9 IMU LEDs

The IMU-IGM-A1, IMU-IGM-S1 and IMU Enclosure (IMU-HG1900, IMU-ISA-100C, IMU-LN200, IMU- μ IMU-IC) have LEDs that provide the IMUs basic status information.

Table 20: IMU-IGM-A1 and IMU-IGM-S1 LEDs

LED	Off	On	Flash Slow (1 Hz)	Flash Fast (3 Hz)
Power (Red)	No power to unit	Unit is powered on	UNKNOWN or UNSUPPORTED IMU	Programming error
GNSS ¹ (Green)	Waiting for GPS time	Time Status FINE or FINESTEERING	Time status COARSE, COARSESTEERING or FREEWHEELING	N/A
INS ¹ (Green)	Not connected to IMU	Connected to IMU	N/A	Bootup or loading firmware

Table 21: IMU Enclosure LEDs

LED	Off	On (Red)	On (Green)	Flash Slow (Yellow, 1 Hz)	Flash Fast (Yellow, 3 Hz)
Power 	No power to IMU Enclosure.	An error occurred during boot up or initialization.	IMU Enclosure is powered on with no errors detected during boot up or initialization.	Boot up and IMU initialization.	N/A
COM 	No communication between IMU Enclosure and GNSS receiver.	N/A	IMU Enclosure is transmitting and receiving data without errors.	IMU Enclosure is receiving data from the receiver, but not transmitting data.	IMU Enclosure is transmitting data to the receiver, but not receiving data.

1. The IMU-IGM-A1 or IMU-IGM-S1 must be connected to a GNSS receiver before the state of these LEDs can change to On.

Chapter 3 SPAN operation

Before operating your SPAN system, ensure that you have followed the installation and setup instructions in *SPAN installation* on page 32.

You can use the NovAtel Application Suite software to configure receiver settings and to monitor data in real-time, between a rover SPAN system and base station.

SPAN system output is compatible with post-processing software from the NovAtel Waypoint Products Group. Visit our web site at novatel.com/products/waypoint-software for details.



Ensure the Control Panel Power Settings on your computer are not set to go into Hibernate or Standby modes. Data will be lost if one of these modes occurs during a logging session.

3.1 Definition of reference frames within SPAN

The reference frames that are most frequently used throughout the SPAN documentation are the following:

- *Local-level frame (ENU)* below
- *IMU body frame* on the next page
- *Vehicle frame* on the next page
- *User output frame* on page 78

3.1.1 *Local-level frame (ENU)*

The definition of the local level coordinate frame is as follows:

- E – pointing east
- N – pointing north
- U – pointing up

Figure 17: Local-level frame (ENU)

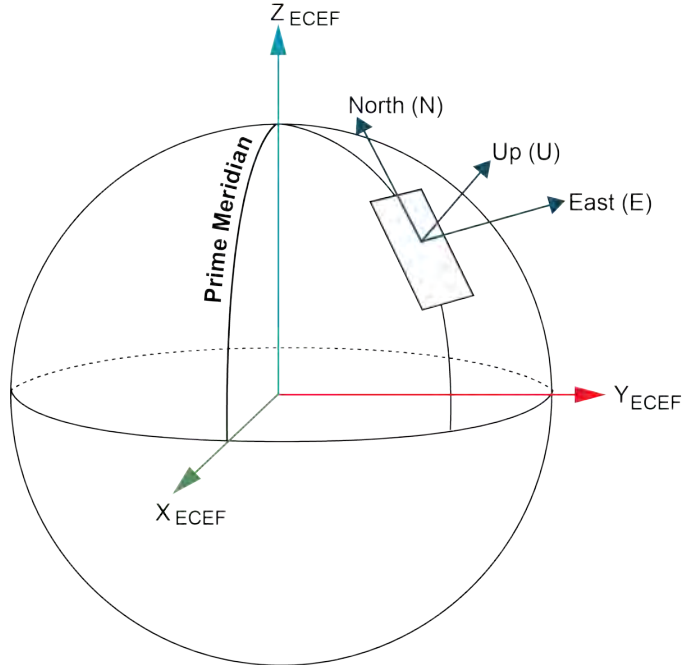

3.1.2 IMU body frame

The definition of the IMU Body frame is given by the physical axes of the IMU and represents how the sensors are mounted inside the IMU. If your IMU is enclosed, both the IMU Body frame axes and centre of navigation are marked on the enclosure. Refer to *IMU technical specifications* on page 144 for illustrations of the IMU Body frame axes.

The origin of this frame is not the enclosure centre, but the centre of navigation (sensor centre).

Figure 18: IMU body frame marking

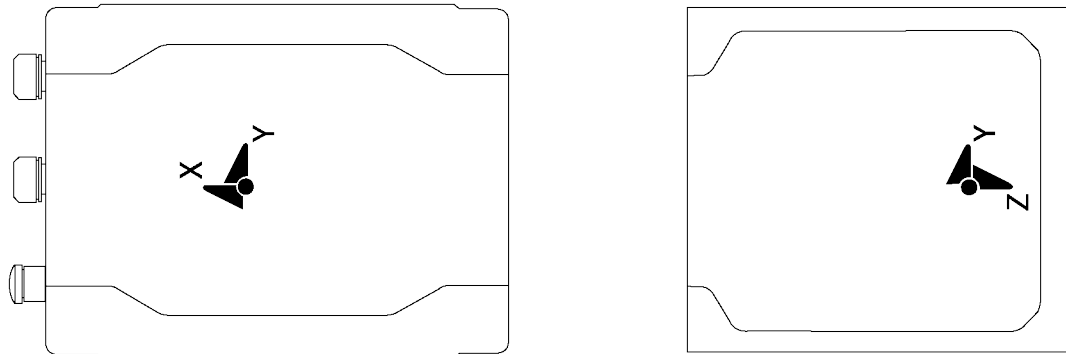

3.1.3 Vehicle frame

The definition of the vehicle frame is as follows:

- z-axis – points up through the roof of the vehicle perpendicular to the ground
- y-axis – points out the front of the vehicle in the direction of travel
- x-axis – completes the right-handed system (out the right-hand side of the vehicle when facing forward)

Figure 19: Vehicle frame

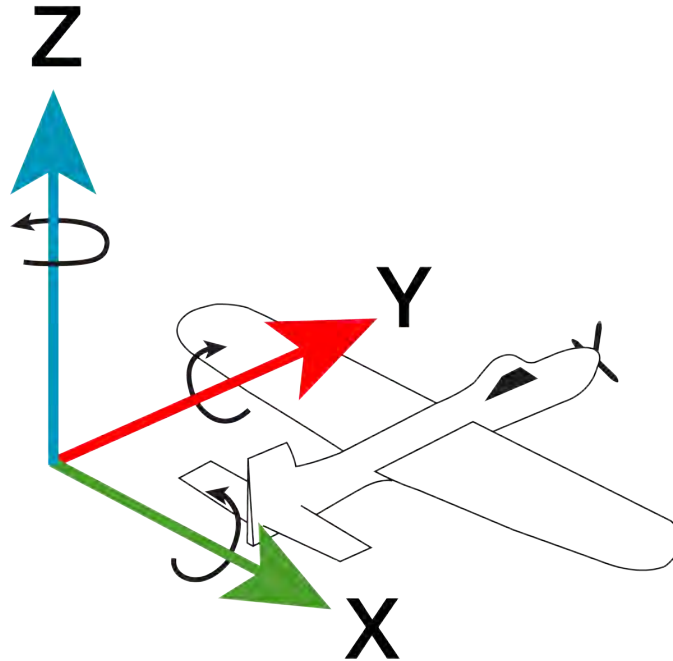

3.1.4 User output frame

The user output frame is an arbitrary frame, which can be optionally defined to transfer inertial output to a more useful position or reference frame.

By default, SPAN position and velocity output is given at the centre of navigation of the IMU. To output position and velocity at a different location, specify a user offset translation using the **SETINSTRLATION** command.

By default, SPAN attitude output is the rotation from the Local-Level frame to the Vehicle frame. If attitude output is desired relative to another frame, specify a user offset rotation using the **SETINSROTATION** command.

3.2 SPAN translations and rotations

A SPAN system combines GNSS and INS into a single system. In a GNSS system, the position is reported relative to the phase centre of the GNSS antenna. In an INS system, the position, velocity and attitude data is reported relative to the centre of navigation of the IMU. For a SPAN system to provide a combined GNSS+INS position, velocity and attitude, it must know where the GNSS antenna is positioned relative to the IMU.

The orientation of the IMU relative to the forward direction of the vehicle is also needed to convert the velocity and attitude changes sensed by the IMU into the actual motion of the vehicle.

If the SPAN system incorporates other devices, such as a camera connected to an Event Input, the SPAN system also needs to know the location and orientation of these additional devices relative to the IMU.

3.2.1 Translational offsets

The three dimensional distances between the IMU and other SPAN components are called translational offsets.

The translational offsets are measured in three directions, X axis, Y axis and Z axis, typically relative to the IMU Body frame. Translational offsets can also be entered relative to the Vehicle frame.



The X, Y and Z axes of the IMU Body frame are typically indicated on the IMU enclosure. The X, Y and Z axes of the IMU Body frame are also indicated on the mechanical drawings of the IMUs in the *IMU technical specifications* on page 144.

Figure 20: IMU to antenna translation offset below shows an example of the translational offsets from the IMU to a GNSS antenna. In this example, the IMU Body Frame (indicated by the small arrows) has the Y axis pointing in the direction of the vehicle motion and the z axis pointing up.

Figure 20: IMU to antenna translation offset

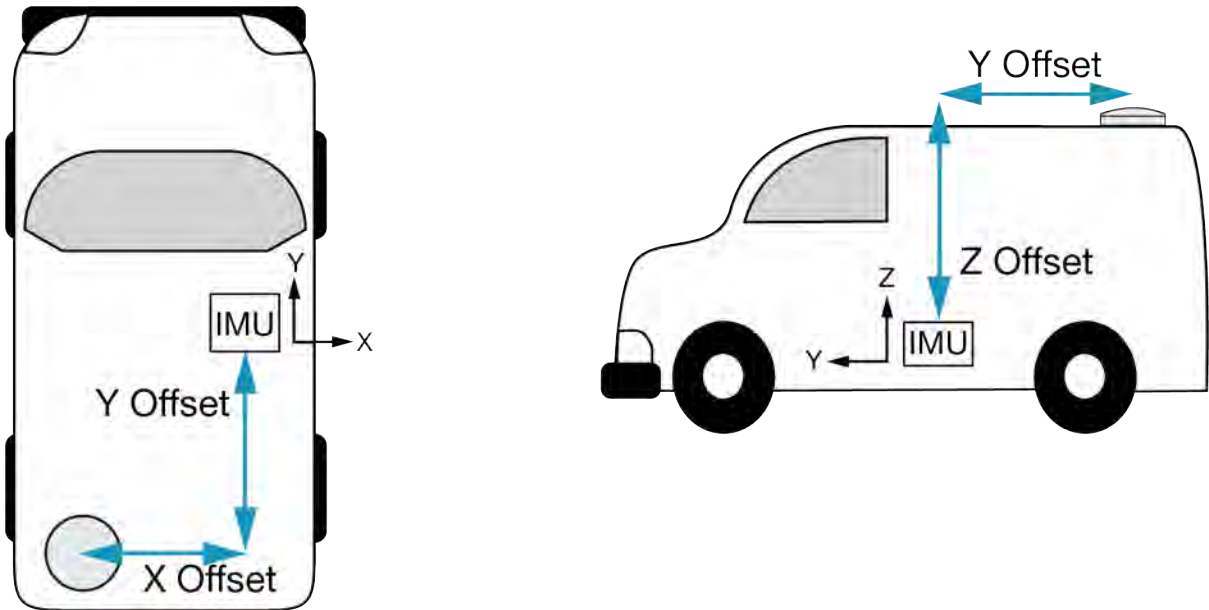

If the distances measured in this example were X Offset = 1.000 m, Y Offset = 1.500 m and Z Offset = 2.000 m, the following values would be entered, based on the IMU Body Frame:

- x = -1.000
- y = -1.500
- z = 2.000

The translational offsets are entered using the **SETINSTRANSLATION** command. For this example, the command to enter these offsets is:

```
SETINSTRANSLATION ANT1 -1 -1.5 2
```



The measurements for the translational offsets should be done as accurately as possible, preferably to within millimetres especially for RTK operation. Any error in the offsets will translate into an error in the INS position.

The translational offsets from the IMU to the GNSS antenna are required for all SPAN systems. However, some SPAN systems may have other sensors or devices integrated into the system for which the SPAN needs translational offsets. For example, a gimbal mount or a camera or LiDAR connected to an Event Input line. The offsets to these additional sensors and devices are also entered using the **SETINSTRANSLATION** command.

By default, the translational offsets are entered in the IMU Body Frame. However, in some systems the IMU Body Frame may not be known precisely. For these cases, the **SETINSTRANSLATION** command has an

option that allows the offsets to be entered relative to the Vehicle Frame. In these cases, the rotation from the IMU Body Frame to the Vehicle Frame (RBV) is used to rotate offsets into the default IMU Body frame as required. To achieve the best results, this means that the RBV rotation must be known very precisely. Typically this is achieved through the SPAN RBV Calibration procedure. See *Body to vehicle frame rotation calibration routine* on page 111 or *Multi-line body to vehicle frame rotation calibration routine* on page 112 for information about this calibration procedure.

3.2.2 Rotational offsets

The differences in orientation between the IMU and other SPAN components are called rotational offsets. Rotational offsets are given as the rotation from the IMU Body Frame to the frame of interest.



The order of rotations is Z-X-Y and all rotations are right handed.

Generally, frames of reference are defined as Z up, with Y forward, and X completing the right-handed system. An example is the vehicle frame, where Z is always considered to be upwards, Y forward through the direction of travel, and X to the right.

Rotational offsets – example

Consider an IMU installed in the following way:

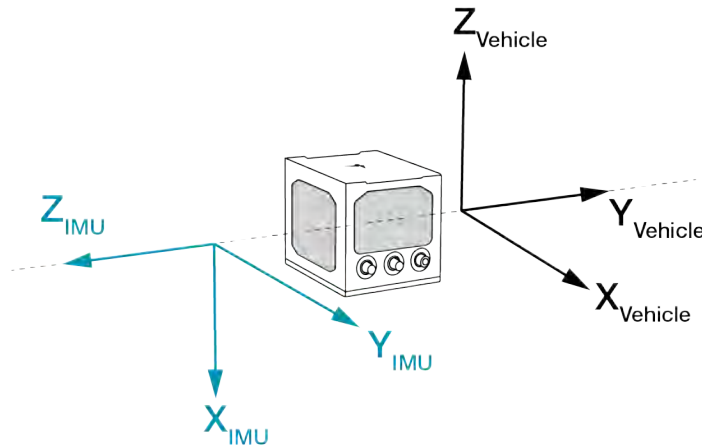

Here, the Euler Angles to rotate from the IMU Body frame to the Vehicle frame (RBV) are:

- X: -90
- Y: 0
- Z: +90

To reach this answer, keep in mind the following rules:

- The goal is to rotate the IMU Body frame to be coincident with the Vehicle frame (i.e. IMU X equals Vehicle X, IMU Y equals Vehicle Y, IMU Z equals Vehicle Z).
- You must rotate from the IMU Body frame to the Vehicle frame.
- You must rotate in the order Z, X, Y.
- Positive rotation is defined according to the right hand rule.

Z rotation:

Observe that if a positive 90 degree rotation is performed about the IMU Z axis, the rotated IMU X axis becomes collinear with the Vehicle X axis.

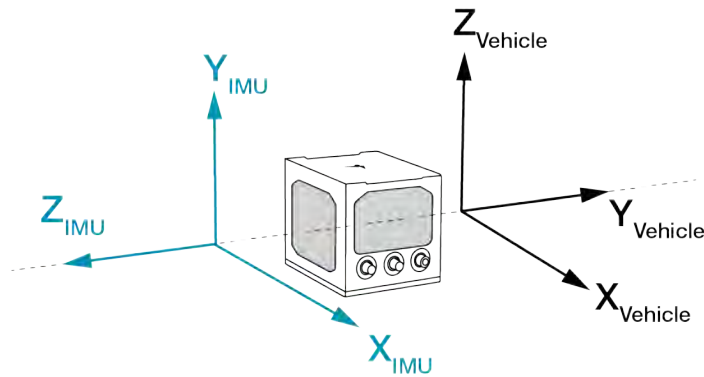

X rotation:

Observe that if a negative 90 degree rotation is performed about the new IMU X axis, the rotated IMU Y axis is now collinear with the Vehicle Y axis, and the rotated IMU Z axis is also collinear with the Vehicle Z axis.

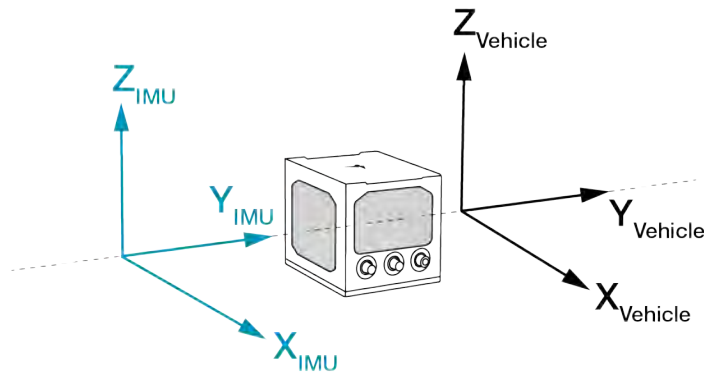

Y rotation:

Since all three sets of axes are already collinear, our frames are coincident, and no further rotation is required.



This solution is not unique. Due to the properties of Euler Angles, there are usually multiple sets of equivalent rotations.

The rotational offsets are entered using the **SETINSROTATION** command. For this example, the command to enter the rotations for the previous example is:

```
SETINSROTATION RBV -90 0 90
```

3.2.3 Output location for logs

The following table lists the output location and frames for OEM7 logs.

Table 22: Output location and frame for logs

Log	Default (position / velocity / heave) output location	Translation offset options (position / velocity / heave) SETINSTRANSATION	Rotational offset options (attitude) SETINSROTATION	Attitude reference frame
CORRIMUS CORRIMUDATA CORRIMUDATAS IMURATECORRIMUS	IMU centre of navigation	N/A	USER > RBV	IMU Body (default) → Vehicle (RBV) → Custom user (USER)

Log	Default (position / velocity / heave) output location	Translation offset options (position / velocity / heave) SETINSTRANSATION	Rotational offset options (attitude) SETINSROTATION	Attitude reference frame
DELAYEDHEAVE	IMU centre of navigation	USER	N/A	N/A
GIMBALLEDPVA	IMU centre of navigation	USER	USER > RBV	IMU Body (default) → Vehicle (RBV) → Custom user (USER)
HEAVE	IMU centre of navigation	USER	N/A	N/A
IMURATEPVA IMURATEPVAS	IMU centre of navigation	USER	USER > RBV	IMU Body (default) → Vehicle (RBV) → Custom user (USER)
INSATT INSATTQS INSATTS INSATTX	IMU centre of navigation	N/A	USER > RBV	IMU Body (default) → Vehicle (RBV) → Custom user (USER)
INSPOS INSPOSS INSPOSX	IMU centre of navigation	USER	N/A	N/A
INSPVA INSPVACMP INSPVAS INSPVAX	IMU centre of navigation	USER	USER > RBV	IMU Body (default) → Vehicle (RBV) → Custom user (USER)
INSSPD INSSPDS	IMU centre of navigation	USER	N/A	N/A
INSVEL INSVELS INSVELX	IMU centre of navigation	USER	N/A	N/A
INSVELUSER	IMU centre of navigation	USER	USER > RBV	IMU Body → Vehicle (RBV) → Custom user (USER)
MARK1PVA TAGGEDMARK1PVA	IMU centre of navigation	MARK1	MARK1	IMU Body (default) → Custom mark (MARK1)
MARK2PVA TAGGEDMARK2PVA	IMU centre of navigation	MARK2	MARK2	IMU Body (default) → Custom mark (MARK2)
MARK3PVA TAGGEDMARK3PVA	IMU centre of navigation	MARK3	MARK3	IMU Body (default) → Custom mark (MARK3)
MARK4PVA TAGGEDMARK4PVA	IMU centre of navigation	MARK4	MARK4	IMU Body (default) → Custom mark (MARK4)
PASHR	IMU centre of navigation	USER	USER > RBV	IMU Body (default) → Vehicle (RBV) → Custom user (USER)

Log	Default (position / velocity / heave) output location	Translation offset options (position / velocity / heave) SETINSTRANSATION	Rotational offset options (attitude) SETINSROTATION	Attitude reference frame
RAWIMU RAWIMUS RAWIMUSX RAWIMUX	IMU centre of navigation	N/A	N/A	IMU Body
SYNCHEAVE	IMU centre of navigation	USER	N/A	N/A
TSS1	IMU centre of navigation	USER	USER > RBV	IMU Body (default) → Vehicle (RBV) → Custom user (USER)
BESTGNSSPOS BESTGNSSVEL	Primary Antenna L1 phase centre	N/A	N/A	N/A
BESTPOS BESTVEL	Primary Antenna L1 phase centre	N/A	N/A	N/A
PDPPOS PDPVEL	Primary Antenna L1 phase centre	N/A	N/A	N/A
PPPPOS	Primary Antenna L1 phase centre	N/A	N/A	N/A
PSRPOS PSRVEL	Primary Antenna L1 phase centre	N/A	N/A	N/A
RTKPOS RTKVEL	Primary Antenna L1 phase centre	N/A	N/A	N/A
BESTXYZ PDPXYZ PPPXYZ PSRXYZ RTKXYZ	Primary Antenna L1 phase centre	N/A	N/A	N/A



Priority of the output frame is indicated by the arrow sign (→) when multiple rotation settings have been configured.



Gimbal Locked Mount Frame backs out the INPUTGIMBALANGLE rotation to output INS in the locked frame, i.e. INS output if no gimbal angles were issued.

3.3 Vibration considerations

When designing a system that integrates SPAN, achieving excellent navigation performance requires considering the vibration environment in which the IMU will operate. IMU sensors measure motion, which may consist of real platform motion but also vibration. The INS mechanises these measurements into a full position, velocity, and attitude solution. Vibration can significantly degrade INS performance by introducing noise or errors into the IMU sensor measurements. It can be especially impactful when unfavourable INS performance conditions are present, like poor GNSS reception, low dynamics and non-optimal configurations. Managing vibration is very important to achieve optimal SPAN system performance.

3.3.1 Sources of error

Vibration affects an INS in several different ways that should be considered.

Noise and errors in the raw IMU measurements can arise from:

- Aliasing – signals at frequencies higher than the sampling rate incorrectly appear at low frequencies or as a bias.
- Clipping – the measurement range of the sensor is exceeded, inducing error in measurements and a bias in the smoothed measurements.
- Vibration Rectification Error (VRE) – changes in vibration induce a bias in the measurements that cannot be filtered out.
- Amplification of standard IMU errors – as measurements approach the range limits of the sensor, even when oscillating around a mean near zero.

INS solution quality experienced at the output from a SPAN system is impacted by:

- IMU lever arm rigidity and accuracy – vibration can cause more flexing and make rigid body assumptions less applicable.
- USER lever arm configuration – oscillation of the INS solution attitude due to vibration amplifies noise and apparent error when the solution is translated to the USER offset.
- SPAN logging configuration (i.e. solution output sampling rate) – insufficient logging rates can cause aliasing in the output solution if oscillation frequency in the INS solution due to vibration exceeds half the output logging rate.

3.3.2 Mitigation methods

Vibration is best mitigated in the mechanical domain prior to IMU exposure. Key methods to mitigate in the mechanical domain include:

- Selecting the IMU mounting location to achieve subsystem separation, structural rigidity considerations, and optimal locations for system dynamics and lever arms.
- Appropriate IMU mounting methods that prioritize rigidity and dimensional stability.
- Carefully designed custom IMU mounts that incorporate vibration isolation features.
- Characterization and minimization of unwanted resonance in the system in the context of system vibration sources.

When the IMU will be exposed to vibration, robust IMU specification design is important to ensure the INS performs adequately in the overall system. For example, the IMU measurement range to avoid signal clipping when exposed to the combination of vibration, maximum system dynamics and gravity. The needs of individual applications will vary and may benefit from an iterative system design approach to manage tradeoffs.

The interface design between the INS and overall system must support the logging configuration and rates needed to minimize solution signal distortion and support any monitoring, post-processing or control loop requirements. Using an anti-aliasing filter at the solution output may be necessary. Contact *Customer Support* on page 22 for additional information.

3.3.3 Additional notes

The unique characteristics of each SPAN system integration requires a tailored vibration management approach within the context of the application. A general solution is not appropriate given the range of vibration environments and system requirements.

An important aspect of the vibration management approach is that changing vibration conditions are most impactful to INS performance.

With careful consideration of vibration early in the system design cycle, optimal SPAN performance can be achieved.



For in-depth information about vibration, please review NovAtel Application Note [APN-112: Inertial Navigation System and Vibration](#).

3.4 Software configuration

On a SPAN system, both the GNSS receiver and the IMU must be configured.

3.4.1 GNSS configuration

The GNSS configuration can be set up for different accuracy levels such as single point, SBAS, DGNSS, PPP and RTK. Refer to the [OEM7 Installation and Operation User Manual](#) for details on DGNSS, RTK, L-band or SBAS setup and operation.

With no additional configuration, the system operates in single point mode.





3.4.2 INS Profiles

INS Profiles provide two major functions; simplified configuration and enhanced performance. Each INS Profile sets specific filter behaviour to enhance system performance in particular environments.

The INS profile settings are enabled by the receiver model. A receiver model with an INS Mode of **S**, **P**, **R** or **K** is required to enable INS Profiles. The INS profile adds enhanced behaviour such as Dead Reckoning for land and Heave for marine and allows for simple configuration rather than sending many discreet commands.

Table 23: OEM7 INS Profiles

Profile	Description	Enhanced Profile settings
DEFAULT	The default SPAN profile. This profile has legacy SPAN default settings.	N/A
LAND	INS Profile for fixed axle land vehicles. Enables robust kinematic alignment routines and configures the update profile.	<p>Enables intelligent vehicle dynamics modelling for land vehicles (Dead Reckoning).</p> <p>Enables course over ground attitude updates.</p> <p>Enables direction detection on kinematic alignment routine.</p> <div style="border: 1px solid black; padding: 5px; margin-top: 10px;"> <p>FW 7.10 Sets alignment velocity to 0.5 m/s.</p> </div>

Profile	Description	Enhanced Profile settings
MARINE	INS profile for marine vessels. Disables static behaviour and configures the marine solution to be more robust.	<p>Disables Zero Velocity Updates (ZUPT).</p> <p>Disables turn-on bias static estimation.</p> <p> Sets alignment velocity to 3.0 m/s.</p>
FIXEDWING	INS profile for fixed wing aircraft	<p> Sets alignment velocity to 3.0 m/s.</p>
FOOT	INS profile for walking or backpack applications	<p> Sets alignment velocity to 0.5 m/s.</p>
VTOL	INS profile for Vertical Take Off and Landing aircraft (helicopter, quadcopter, etc.)	None
RAIL	INS profile for railway applications	<p>Enables intelligent vehicle dynamics modelling for rail vehicles (Dead Reckoning).</p> <p>Enables course over ground attitude updates.</p> <p>Enables direction detection on kinematic alignment routine.</p> <p> Sets alignment velocity to 5.0 m/s.</p>
AGRICULTURE	INS profile for agriculture applications	<p>Enables intelligent vehicle dynamics modelling for agricultural vehicles (Dead Reckoning).</p> <p>Enables course over ground attitude updates.</p> <p>Enables direction detection on kinematic alignment routine.</p> <p> Sets alignment velocity to 0.5 m/s.</p>

Use

To use an INS Profile, send the **SETINSPROFILE** command at startup (or save to NVM) to activate the mode. For example:

```
SETINSPROFILE LAND
```

The type of profile activated, basic or enhanced, is determined by the SPAN model.



The currently selected profile option is available in the **INSCONFIG** log.

RBV calibration

For the profiles to provide the greatest benefit, the rotation offset of the IMU body to the vehicle frame (RBV) should be known as accurately as possible. Since constraints happen at the vehicle level, any error in the offset will translate into worse performance. These parameters are estimated in the background when the system is fully converged, however it is always better to have this measured as precisely as possible before mission critical data is collected.

The INSCALIBRATE RBV functionality can be used to estimate and save these offsets to NVM in a controlled manner.

3.4.3 SPAN configuration

- *Minimum recommended configuration* below
- *Configure SPAN manually* on the next page
- *SPAN configuration with NovAtel Application Suite* on page 91
- *SPAN configuration with Manage Web* on page 91

Minimum recommended configuration

When configuring your OEM7 SPAN system for first time use, the following is the minimum amount of information required to ensure proper operation of a SPAN system.

Required information	Required command
IMU type and communication port	CONNECTIMU
IMU to primary antenna lever arm	SETINSTRANSFORMATION ANT1
IMU to vehicle frame rotation	SETINSROTATION RBV



For optimal SPAN operation, the IMU to antenna lever arms and the IMU to vehicle frame rotation should be measured or calibrated to the best accuracy possible. Even small errors in the lever arm or RBV can lead to significant degradation of the overall INS performance.

While this is the minimum amount of information required, additional information is typically needed for SPAN systems. The following commands are commonly used to configure SPAN systems.

Common user settings	Appropriate command	Notes
IMU to secondary antenna lever arm	SETINSTRANSALATION ANT2	Only required for dual antenna systems
IMU to output position offset	SETINSTRANSALATION USER	Default output position is at the IMU centre
IMU to output frame rotation	SETINSROTATION USER	Default output frame is the vehicle frame as defined by SETINSROTATION RBV input
Vehicle type	SETINSPROFILE	
Minimum alignment velocity	SETALIGNMENTVEL	

Configure SPAN manually

Follow these steps to enable INS as part of the SPAN system using software commands:



A GNSS antenna with a clear view of the sky must be connected and tracking satellites for operation.

1. Issue the **CONNECTIMU** command to specify the type of IMU being used and the receiver port connected to the IMU, see *Table 24: Enable INS commands* below and the **CONNECTIMU** command.

Table 24: Enable INS commands

IMU type	CONNECTIMU command
HG1700 AG11	CONNECTIMU COMx HG1700_AG11
HG1700 AG17	CONNECTIMU COMx HG1700_AG17
HG1700 AG58	CONNECTIMU COMx HG1700_AG58
HG1700 AG62	CONNECTIMU COMx HG1700_AG62
IMU-CPT	CONNECTIMU COMx KVH_COTS
IMU-FSAS	CONNECTIMU COMx IMAR_FSAS
IMU-HG1900	CONNECTIMU COMx HG1900_CA50
IMU-IGM-A1	CONNECTIMU COMx ADIS16488
IMU-IGM-S1	CONNECTIMU COMx STIM300
IMU-ISA-100C	CONNECTIMU COMx ISA100C
IMU-KVH1750	CONNECTIMU COMx KVH_1750
IMU-LN200 IMU-LN200C	CONNECTIMU COMx LN200

IMU type	CONNECTIMU command
IMU-P1750	CONNECTIMU COMx KVH_1750
IMU- μ IMU-IC	CONNECTIMU COMx LITEF_MICROIMU
OEM-HG1900 (CA50)	CONNECTIMU COMx HG1900_CA50
OEM-HG1930 (CA50)	CONNECTIMU COMx HG1930_CA50
OEM-IMU-ADIS-16488	CONNECTIMU COMx ADIS16488 ¹ CONNECTIMU SPI ADIS16488 ²
OEM-IMU-EG320N	CONNECTIMU SPI EPSON_G320 CONNECTIMU SPI EPSON_G320_200HZ
OEM-IMU-EG370N	CONNECTIMU SPI EPSON_G370
OEM-IMU-HG4930 (AN01)	CONNECTIMU COMx HG4930_AN01
OEM-IMU-HG4930 (AN04)	CONNECTIMU COMx HG4930_AN04 CONNECTIMU COMx HG4930_AN04_400HZ
OEM-IMU-ISA-100C	CONNECTIMU COMx ISA100C
OEM-IMU-STIM300	CONNECTIMU COMx STIM300 ³ CONNECTIMU COMx STIM300D ⁴
OEM-IMU- μ IMU-IC	CONNECTIMU COMx LITEF_MICROIMU ⁵
OEM-IMU- μ IMU-UART	CONNECTIMU COMx LITEF_MICROIMUD_400HZ ⁶
UIMU-HG1700-AG58	CONNECTIMU COMx HG1700_AG58
UIMU-HG1700-AG62	CONNECTIMU COMx HG1700_AG62
UIMU-LN200	CONNECTIMU COMx LN200



Use the COM port number the IMU is connected to. If you are using the OEM719+MIC board stack, you must use COM1. For SPAN systems with a OEM729 receiver, COM2 is the recommended serial port for the IMU, however you can use any available port for these IMUs.

1. When the OEM-IMU-ADIS16488 is connected using a MIC.
2. When the OEM-IMU-ADIS16488 is connected directly to an OEM7 receiver.
3. When the OEM-IMU-STIM300 is connected using a MIC.
4. When the OEM-IMU-STIM300 is connected directly to an OEM7 receiver.
5. When the OEM-IMU- μ IMU-IC is connected using a UIC.
6. When the OEM-IMU- μ IMU-IC-UART is connected directly to an OEM7 receiver.

- If the SPAN system uses an OEM-HG1900 IMU connected to a MIC card, issue the following command.

```
SETIMUPORTPROTOCOL RS232
```

Basic configuration of the SPAN system is now complete. The inertial filter starts after the GNSS solution is solved and the IMU is connected.

- Issue the **SETINSTRANSLATION** command, using the **ANT1** parameter, to enter the distance from the IMU to the GNSS antenna. See the **SETINSTRANSLATION** command in the [OEM7 Commands and Logs Reference Manual](#) for more information.

If the SPAN receiver has dual antenna inputs, issue the **SETINSTRANSLATION** command, using the **ANT2** parameter, to enter the distance from the IMU to the secondary GNSS antenna.

The offset between the antenna phase centre and the IMU axis must remain constant and be known accurately (m). The X, Y and Z directions are clearly marked on the IMU enclosure. The SETINSTRANSLATION parameters are (where the standard deviation fields are optional and the distances are measured from the IMU to the antenna):

```
ANT1 x_offset y_offset z_offset [x_stdev] [y_stdev] [z_stdev]
```

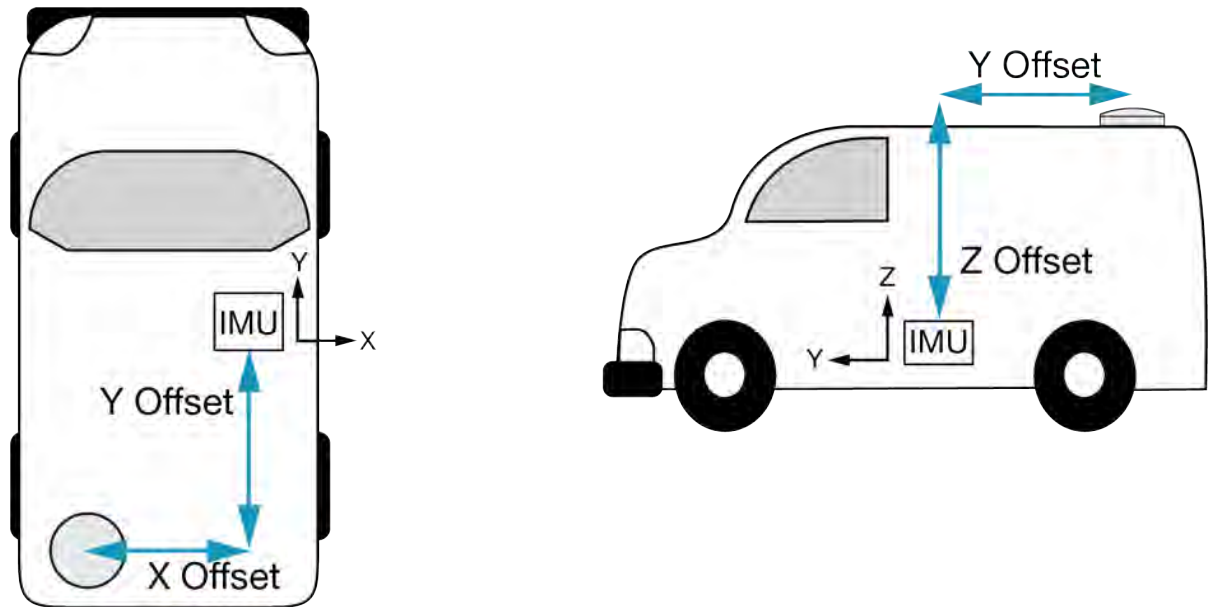

This example shows a mounting configuration with a negative X offset, negative Y offset and positive Z offset.

A typical RTK GNSS solution is accurate to a few centimetres. For the integrated GNSS+INS system to have this level of accuracy, the offset must be measured to within a centimetre. Any offset error between the two systems shows up directly in the output position. For example, a 10 cm error in recording this offset will result in at least a 10 cm error in the output.

If it is impossible to measure the IMU to GNSS antenna offset precisely, the offset can be estimated by carrying out the Lever Arm Calibration Routine. See *Lever arm calibration routine* on page 110.



The Lever Arm Calibration routine is not available for the OEM-HG1930, OEM-IMU-ADIS-16488, OEM-IMU-EG320N, OEM-IMU-EG370N, OEM-IMU-HG4930, OEM-IMU-STIM300, IMU-CPT, IMU-IGM-A1, IMU-IGM-S1, PwrPak7-E1, PwrPak7D-E1, PwrPak7-E2, PwrPak7D-E2, CPT7 or CPT7700.

- Issue the **SETINSROTATION** command, using the **RBV** parameter, to enter the Euler Angle rotation from the IMU Body frame to the Vehicle frame. See the **SETINSROTATION** command in the [OEM7 Commands and Logs Reference Manual](#) for more information.

Accurate knowledge of the rotational offset between the IMU Body frame and the Vehicle frame (the RBV rotation) is critical to correctly computing an attitude solution, and is required before a Kinematic alignment is possible.

The SETINSROTATION parameters are (where the standard deviation fields are optional):

```
RBV x_rotation y_rotation z_rotation [x_stddev] [y_stddev] [z_stddev]
```



The order of rotations is Z-X-Y. All rotations are right handed.

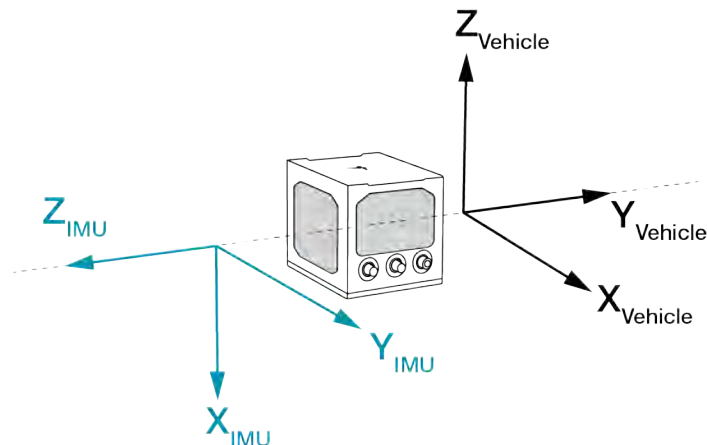

For an example of how to solve for the IMU Body to Vehicle frame rotation refer to *Rotational offsets* on page 80.

If the rotation between the IMU Body frame and the Vehicle frame is not precisely known, enter an approximate rotation (to the nearest 45 degrees). The precise offset can be estimated by carrying out the *Body to vehicle frame rotation calibration routine* on page 111.

SPAN configuration with NovAtel Application Suite

NovAtel Application Suite provides a graphical user interface to help configure a SPAN system. For information about configuring SPAN using NovAtel Application Suite, refer to docs.novatel.com/Tools/Content/ToolsSuite/Overview.htm.

SPAN configuration with Manage Web

The SPAN parameters can be configured using the NovAtel Manage Web User Interface. For information about using Manage Web, refer to docs.novatel.com/Tools/Content/Manage_Web/Overview.htm.

3.4.4 SPAN configuration for PwrPak7

- *Minimum recommended configuration below*
- *Configure SPAN manually below*
- *SPAN configuration with NovAtel Application Suite on page 96*
- *SPAN configuration with Manage Web on page 96*

Minimum recommended configuration

When configuring your PwrPak7 system for first time use, the following is the minimum amount of information required to ensure proper operation of a SPAN system.

Required information	Required command
IMU type and communication port (PwrPak7 and PwrPak7D only)	CONNECTIMU
IMU to primary antenna lever arm	SETINSTRANSULATION ANT1
IMU to vehicle frame rotation	SETINSROTATION RBV

For optimal SPAN operation, the IMU to antenna lever arms and the IMU to vehicle frame rotation should be measured or calibrated to the best accuracy possible. Even small errors in the lever arm or RBV can lead to significant degradation of the overall INS performance.

While this is the minimum amount of information required, additional information is typically needed for SPAN systems. The following commands are commonly used to configure SPAN systems.

Common user settings	Appropriate command	Notes
IMU to secondary antenna lever arm	SETINSTRANSULATION ANT2	Only required for dual antenna systems
IMU to output position offset	SETINSTRANSULATION USER	Default output position is at the IMU centre
IMU to output frame rotation	SETINSROTATION USER	Default output frame is the vehicle frame as defined by SETINSROTATION RBV input
Vehicle type	SETINSPROFILE	
Minimum alignment velocity	SETALIGNMENTVEL	

Configure SPAN manually

Follow these steps to enable INS as part of the PwrPak7 system using software commands:



A GNSS antenna with a clear view of the sky must be connected and tracking satellites for operation.

1. Issue the **CONNECTIMU** command to specify the type of IMU being used and the receiver port connected to the IMU, see *Table 25: Enable INS commands* below and the **CONNECTIMU** command.



Do not use the CONNECTIMU command on PwrPak7-E1, PwrPak7D-E1, PwrPak7-E2 or PwrPak7D-E2 receivers.

The system is configured at the factory for the internal IMU (EG320N or EG370N) and changing the IMU configuration can impair SPAN operation.

Table 25: Enable INS commands

IMU type	CONNECTIMU command
HG1700 AG11	CONNECTIMU COMx HG1700_AG11
HG1700 AG17	CONNECTIMU COMx HG1700_AG17
HG1700 AG58	CONNECTIMU COMx HG1700_AG58
HG1700 AG62	CONNECTIMU COMx HG1700_AG62
IMU-CPT	CONNECTIMU COMx KVH_COTS
IMU-FSAS	CONNECTIMU COMx IMAR_FSAS
IMU-HG1900	CONNECTIMU COMx HG1900_CA50
IMU-IGM-A1	CONNECTIMU COMx ADIS16488
IMU-IGM-S1	CONNECTIMU COMx STIM300
IMU-ISA-100C	CONNECTIMU COMx ISA100C
IMU-KVH1750	CONNECTIMU COMx KVH_1750
IMU-LN200 IMU-LN200C	CONNECTIMU COMx LN200
IMU-P1750	CONNECTIMU COMx KVH_1750
IMU- μ IMU-IC	CONNECTIMU COMx LITEF_MICROIMU
OEM-HG1900 (CA50)	CONNECTIMU COMx HG1900_CA50
OEM-HG1930 (CA50)	CONNECTIMU COMx HG1930_CA50
OEM-IMU-ADIS-16488	CONNECTIMU COMx ADIS16488 ¹
OEM-IMU-HG4930 (AN01)	CONNECTIMU COMx HG4930_AN01
OEM-IMU-HG4930 (AN04)	CONNECTIMU COMx HG4930_AN04 CONNECTIMU COMx HG4930_AN04_400HZ

1. When the OEM-IMU-ADIS16488 is connected using a MIC.

IMU type	CONNECTIMU command
OEM-IMU-ISA-100C	CONNECTIMU COMx ISA100C
OEM-IMU-STIM300	CONNECTIMU COMx STIM300 ¹ CONNECTIMU COMx STIM300D ²
OEM-IMU- μ IMU-IC	CONNECTIMU COMx LITEF_MICROIMU ³
OEM-IMU- μ IMU-UART	CONNECTIMU COMx LITEF_MICROIMUD_400HZ ⁴
UIMU-HG1700-AG58	CONNECTIMU COMx HG1700_AG58
UIMU-HG1700-AG62	CONNECTIMU COMx HG1700_AG62
UIMU-LN200	CONNECTIMU COMx LN200



Use the COM port number the IMU is connected to.

- Issue the **SETINSTRANSLATION** command, using the **ANT1** parameter, to enter the distance from the IMU, PwrPak7-E1, PwrPak7D-E1, PwrPak7-E2 or PwrPak7D-E2 to the primary GNSS antenna.

Issue the **SETINSTRANSLATION** command, using the **ANT2** parameter, to enter the distance from the IMU or PwrPak7D-E1 to the secondary GNSS antenna. (Required only for the PwrPak7D, PwrPak7D-E1 or PwrPak7D-E2)

See the **SETINSTRANSLATION** command in the [OEM7 Commands and Logs Reference Manual](#) for more information.

The offset between the antenna phase centre and the IMU axis must remain constant and be known accurately (m). If using a PwrPak7-E1, PwrPak7D-E1, PwrPak7-E2 or PwrPak7D-E2, the X, Y and Z directions are clearly marked on the PwrPak7 enclosure. If using a PwrPak7 or PwrPak7D and an external IMU, the X, Y and Z directions are clearly marked on the IMU enclosure. The SETINSTRANSLATION parameters are (where the standard deviation fields are optional and the distances are measured from the IMU, PwrPak7-E1, PwrPak7D-E1, PwrPak7-E2 or PwrPak7D-E2 to the antenna):

```
ANT1 x_offset y_offset z_offset [x_stdev] [y_stdev] [z_stdev]
```

- When the OEM-IMU-STIM300 is connected using a MIC.
- When the OEM-IMU-STIM300 is connected directly to an OEM7 receiver.
- When the OEM-IMU- μ IMU-IC is connected using a UIC.
- When the OEM-IMU- μ IMU-IC-UART is connected directly to an OEM7 receiver.

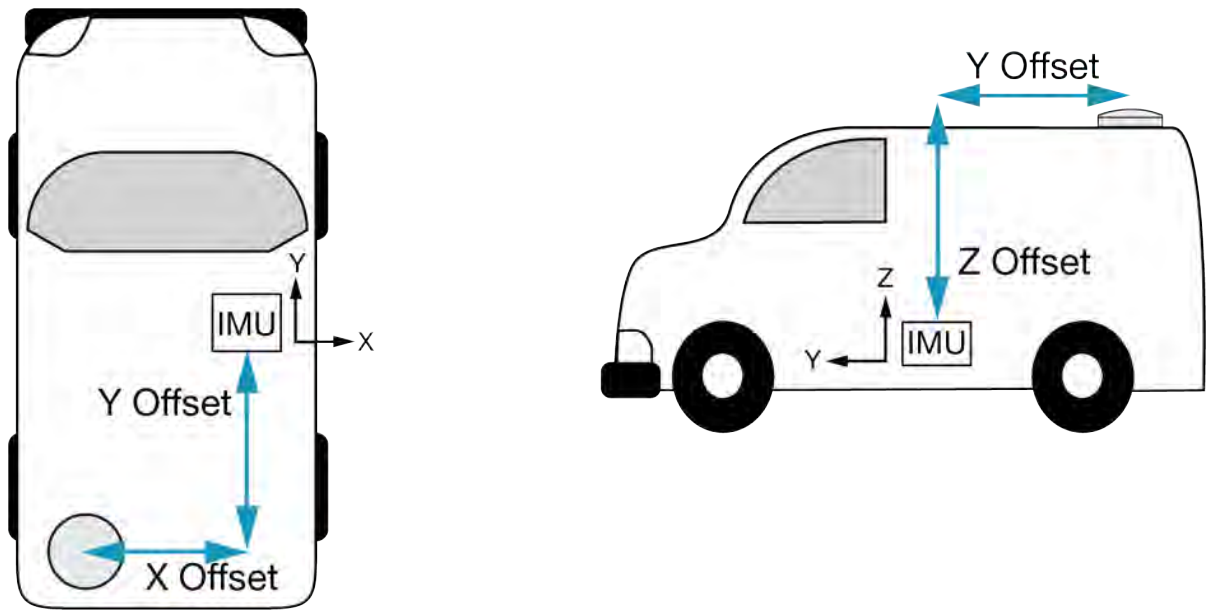

This example shows a mounting configuration with a negative X offset, negative Y offset and positive Z offset.

A typical RTK GNSS solution is accurate to a few centimetres. For the integrated GNSS+INS system to have this level of accuracy, the offset must be measured to within a centimetre. Any offset error between the two systems shows up directly in the output position. For example, a 10 cm error in recording this offset will result in at least a 10 cm error in the output.

If it is impossible to measure the IMU to GNSS antenna offset precisely, the offset can be estimated by carrying out the Lever Arm Calibration Routine. See *Lever arm calibration routine* on page 110.



The Lever Arm Calibration routine is not available for the OEM-HG1930, OEM-IMU-ADIS-16488, OEM-IMU-EG320N, OEM-IMU-EG370N, OEM-IMU-HG4930, OEM-IMU-STIM300, IMU-CPT, IMU-IGM-A1, IMU-IGM-S1, PwrPak7-E1, PwrPak7D-E1, PwrPak7-E2, PwrPak7D-E2, CPT7 or CPT7700.

- Issue the **SETINSROTATION** command, using the **RBV** parameter, to enter the Euler Angle rotation from the IMU Body frame to the Vehicle frame. See the **SETINSROTATION** command in the [OEM7 Commands and Logs Reference Manual](#) for more information.

Accurate knowledge of the rotational offset between the IMU Body frame and the Vehicle frame (the RBV rotation) is critical to correctly computing an attitude solution, and is required before a Kinematic alignment is possible.

The SETINSROTATION parameters are (where the standard deviation fields are optional):

```
RBV x_rotation y_rotation z_rotation [x_stddev] [y_stddev] [z_stddev]
```



The order of rotations is Z-X-Y. All rotations are right handed.

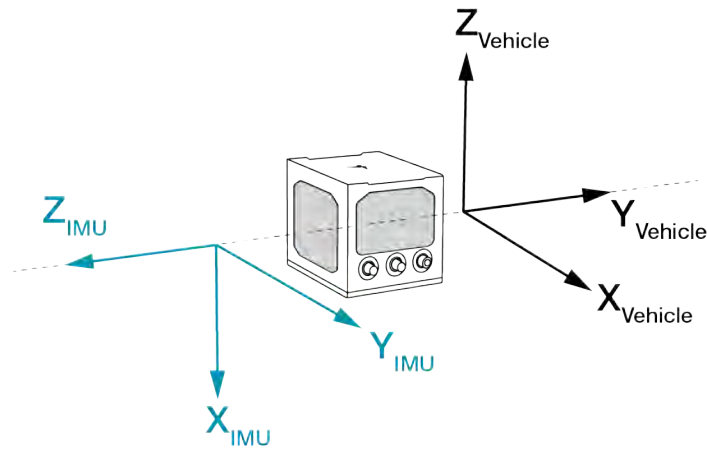

For an example of how to solve for the IMU Body to Vehicle frame rotation refer to *Rotational offsets* on page 80.

If the rotation between the IMU Body frame and the Vehicle frame is not precisely known, enter an approximate rotation (to the nearest 45 degrees). The precise offset can be estimated by carrying out the *Body to vehicle frame rotation calibration routine* on page 111.

SPAN configuration with NovAtel Application Suite

NovAtel Application Suite provides a graphical user interface to help configure a SPAN system. For information about configuring SPAN using NovAtel Application Suite, refer to docs.novatel.com/Tools/Content/ToolsSuite/Overview.htm.

SPAN configuration with Manage Web

The SPAN parameters can be configured using the NovAtel Manage Web User Interface. For information about using Manage Web, refer to docs.novatel.com/Tools/Content/Manage_Web/Overview.htm.

3.4.5 Importance of lever arms

For the SPAN system to provide optimum performance, the lever arm of the IMU to the antenna should be measured as accurately as possible. The accuracy of the lever arm measurement impacts the accuracy of the INS solution PVA output. The type of the GNSS positioning used is also a factor. For example, an application using single point GNSS requires less accurate lever arm measurements compared to an application using RTK requiring centimetre level accuracy.

In general, the lever arm measurements should be measured to a better accuracy than the desired INS PVA output accuracy. The accuracy of the GNSS position is also a factor in the overall accuracy. For example, if the desired INS accuracy level is to be within 3 cm, and RTK positioning with an accuracy of 2 cm is used, then the lever arms must be measured to an accuracy level better than 1 cm. This results in an overall accuracy level of 3 cm (2 cm for RTK and 1 cm for INS).

The location of the IMU with respect to the primary antenna is also important. The IMU should be placed as close as possible to the primary antenna for the best performance. This is not always practical so longer lever arm lengths are okay. However as the lever arm distance increases, the accuracy of the lever arm measurement becomes more important.

Finally, when entering the lever arm into the SPAN system via the **SETINSTRANSLATION** command, the standard deviations of the lever arm measurement are also entered. This is an estimate of how accurate the lever arms were measured. These standard deviations should be entered with correct accuracies for their measurements. An incorrect lever arm standard deviation, either pessimistic or optimistic, might have negative impacts on SPAN performance.

Measuring the lever arm

One method of measuring the lever arm is to use a total station and perform a survey between the IMU and the antenna. This method is ideal when the IMU and antenna are in a permanent location in the vehicle and will not be removed for an extended period. A survey will normally provide very accurate lever arm measurements so this is the best option when using RTK.

Figure 21: Antenna lever arm – total station

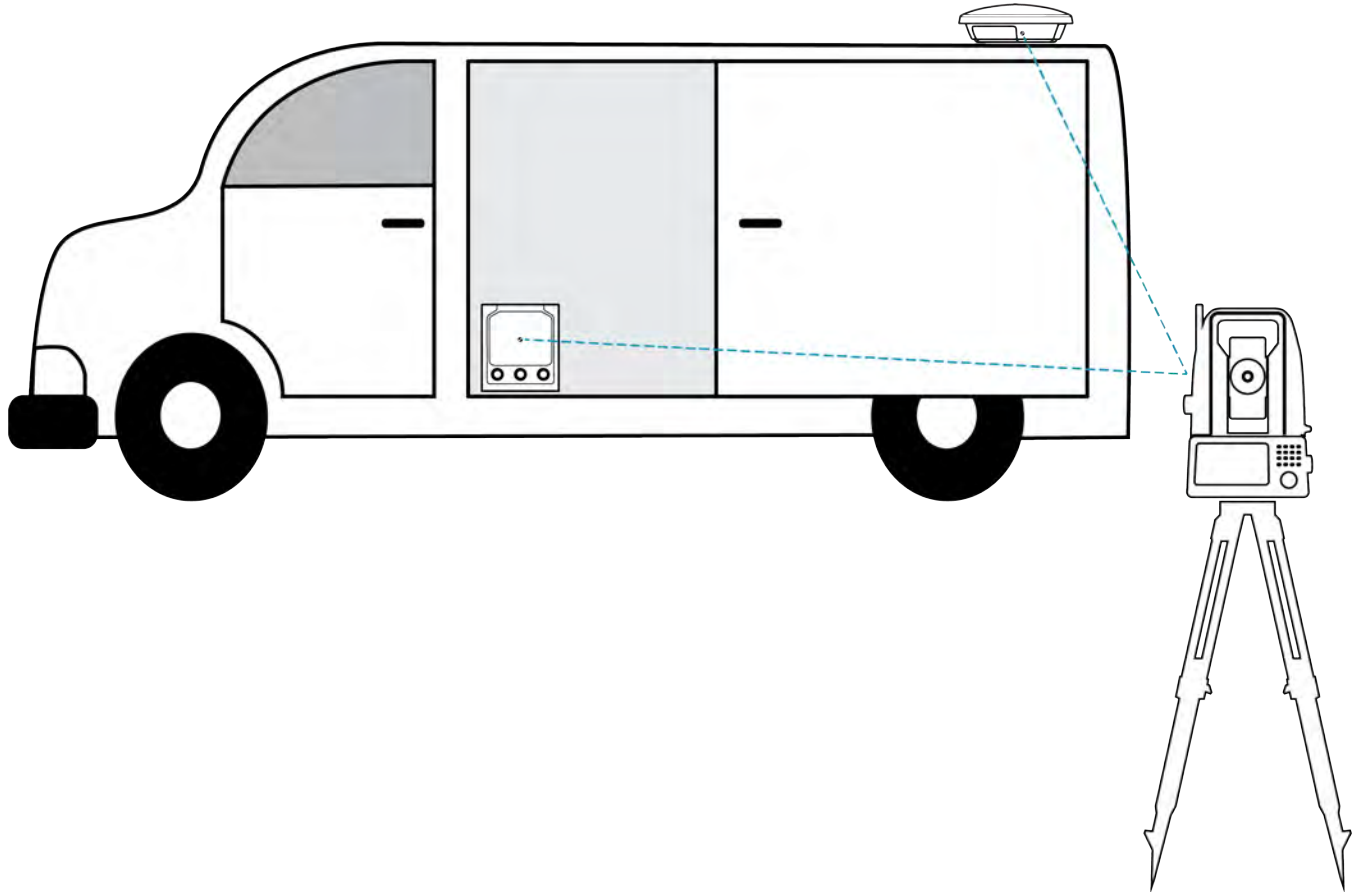

Performing a survey with a total station can be time consuming and expensive, so a simpler method is to use a measuring tape and a plumb bob. The vehicle should be level when measuring is done. The first measurement should be the Z axis starting at the antenna to the surface where the IMU is mounted. This measurement should be done with both the plumb bob and the measuring tape. Once this measurement is completed, the X and Y axis measurements can be done with only the measuring tape.

Figure 22: Antenna lever arm – tape measure

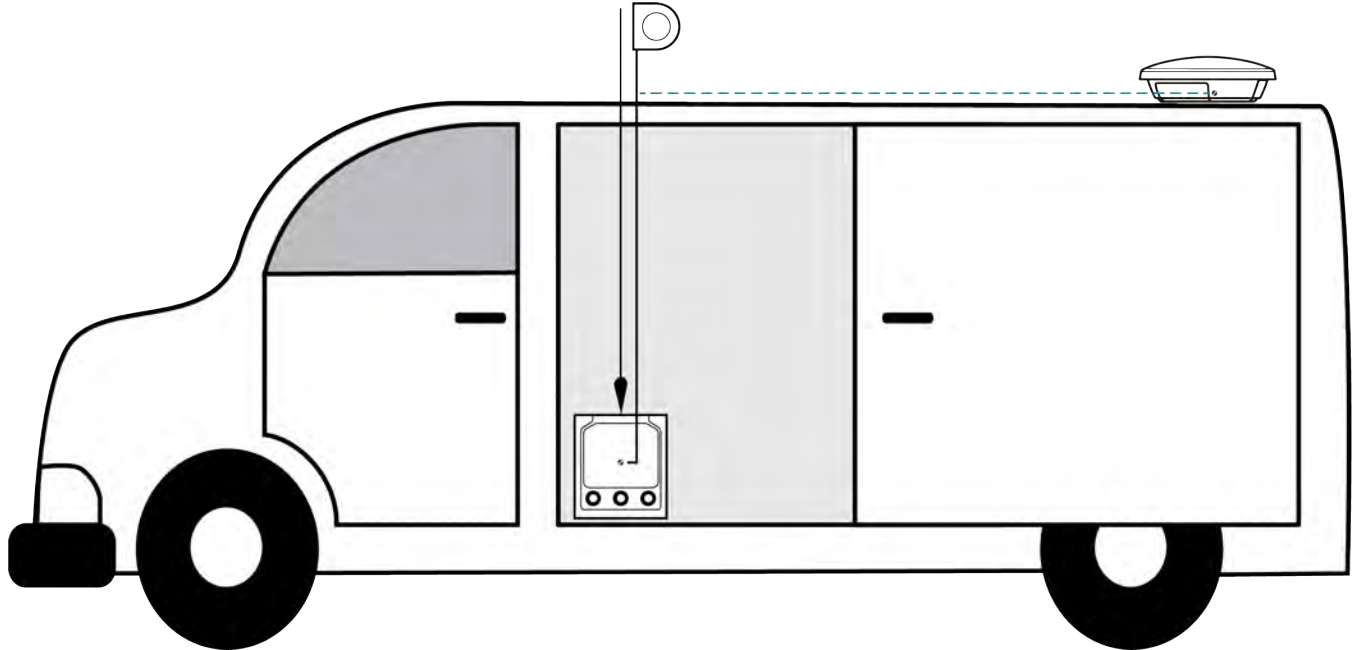

3.4.6 Importance of RBV calibration

For the SPAN system to provide the best performance, the rotation offset of the IMU body to the Vehicle frame (RBV) should be known as accurately as possible. Since constraints happen at the vehicle level, any error in the offset will translate into worse performance.

After the SPAN system has been installed and the appropriate translations and rotations have been applied (see *SPAN translations and rotations* on page 78), the IMU Body frame is aligned with the Vehicle frame. However, aspects of the mounting platform and vehicle design, such as roof camber or tilt, and slight misalignments in installation can cause the IMU Body frame to be slightly out of alignment with the Vehicle frame. The misalignment of the IMU Body frame from the Vehicle frame will add a bias to the SPAN solution.

The following diagrams show examples of a PwrPak7-E1 installed in a vehicle with misalignment issues.

Figure 23: Rear view of PwrPak7-E1 – mounting plate is not flat

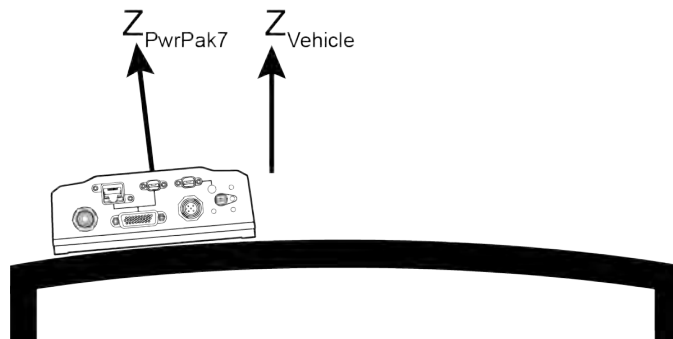
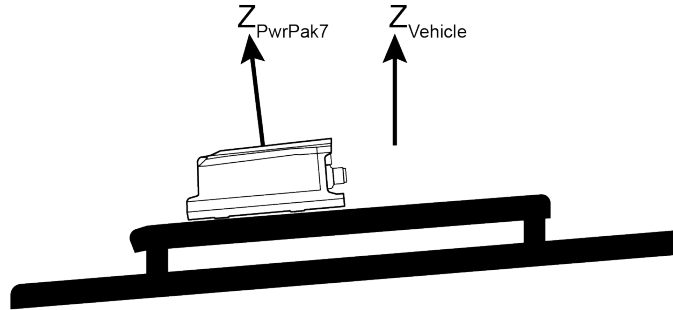
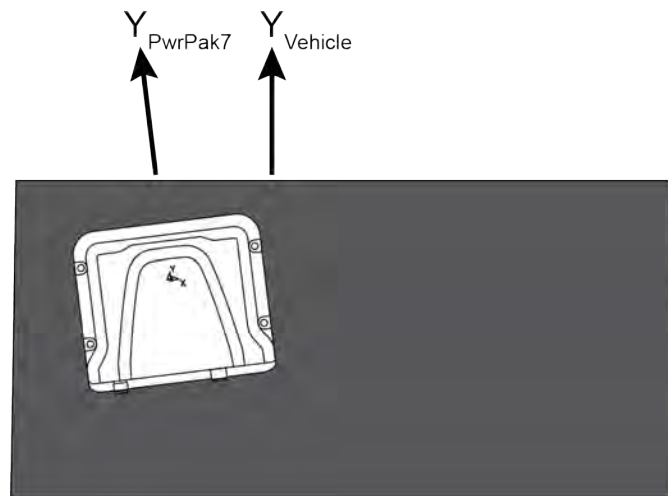

Figure 24: Side view of PwrPak7-E1 – vehicle is not level**Figure 25: Top view of PwrPak7-E1 – PwrPak7-E1 misalignment**

The misalignments shown in the previous figures have been exaggerated for illustration purposes.

In a typical SPAN system installation, the slight misalignments shown in the examples above are hard to detect and difficult to measure. For this reason, it is recommended that a Body to Vehicle Frame rotation calibration routine be used so the SPAN system can determine and compensate for these angles. Refer to *Body to vehicle frame rotation calibration routine* on page 111 or *Multi-line body to vehicle frame rotation calibration routine* on page 112 for more information.

These parameters are estimated in the background when the system is fully converged, however it is always better to have this measured as precisely as possible before mission critical data is collected.



Since slight variations in alignment can be introduced when the IMU or PwrPak7-E1 is remounted, a Body to Vehicle Frame calibration should be performed each time the device is remounted.



An accurate RBV is especially important if the position is being transferred to a user offset.

3.4.7 Importance of antenna location for ALIGN

To achieve the best SPAN performance when using dual antenna (ALIGN):

- the two GNSS antennas should be mounted on the vehicle securely in a stable location
- the two GNSS antennas should be mounted as far apart as possible
- the two GNSS antennas should be mounted away from other vehicle obstructions resulting in a clear view of the sky
- the primary GNSS antenna should be mounted as close as possible to the IMU

The primary and secondary GNSS antenna can be mounted anywhere on the vehicle with a fixed distance (baseline) between them. The baseline between the two antennas does not need to be aligned with the vehicle axes or with the axes of the IMU.

The heading accuracy is dependent on the antenna baseline length. For best performance, mount the antennas as far apart as possible. A separation of 1 metre is the minimum recommended distance. At a baseline length of 1 metre, the ALIGN accuracy is 0.20°. If the baseline length were 0.5 metre, the ALIGN accuracy would be 0.40°. A 2 metre baseline results in an ALIGN accuracy of 0.08°.

Finally, the primary antenna should be mounted as close as possible to the IMU while still maintaining a maximum antenna baseline length. This may lead to some compromise being made for the primary antenna location. Preference should be put on keeping the primary antenna closer to the IMU even it results in a shorter baseline between the two GNSS antennas.

As with the primary antenna lever arm, it is also important to have the best possible accuracy on the IMU to the secondary antenna lever arm (refer to the *Importance of lever arms* on page 96). However, as measuring lever arms can be difficult, an alternative is to calibrate the IMU Body frame to ALIGN frame rotation using the **INSCALIBRATE** command or to measure that rotation directly and enter it using the **SETINSROTATION** command.

3.5 Real-time operation

SPAN operates through the OEM7 command and log interface. Refer to the [OEM7 Commands and Logs Reference Manual](#) log and command details.

Real-time operation notes:

- By default, raw IMU data will begin to output as soon as the IMU is connected. However, an initial position is required to begin the INS alignment process. This position is typically set by GNSS. The GNSS position will not be used until the FINESTEERING time status is reached. This requires a GNSS antenna connected with a clear view of the sky. See *System start-up and alignment techniques* on the next page for more details.
- The inertial solution is computed separately from the GNSS solution. The GNSS solution is available from the SPAN system through the GNSS-specific logs, even without SPAN running. The integrated GNSS+INS solution is available through special INS logs documented in SPAN Logs in the [OEM7 Commands and Logs Reference Manual](#).
- The IMU raw data is available at the maximum rate of output of the IMU. Because of this high data rate, a shorter header format was created. These shorter header logs are defined with an S (RAWIMUSXB rather than RAWIMUXB). We recommend you use these logs instead of the standard header logs to save throughput on the COM port.

Status of the inertial solution can be monitored using the inertial status field in the INS logs.

Table 26: Inertial solution status

Binary	ASCII	Description
0	INS_INACTIVE	IMU logs are present, but the alignment routine has not started; INS is inactive.
1	INS_ALIGNING	INS is in alignment mode.
2	INS_HIGH_VARIANCE	The INS solution uncertainty contains outliers and the solution may be outside specifications. ¹ The solution is still valid but you should monitor the solution uncertainty in the INSSTDEV log. It may be encountered during times when GNSS is absent or poor.
3	INS_SOLUTION_GOOD	The INS filter is in navigation mode and the INS solution is good.
6	INS_SOLUTION_FREE	The INS Filter is in navigation mode and the GNSS solution is suspected to be in error. The inertial filter will report this status when there are no available updates (GNSS or other) being accepted and used.
7	INS_ALIGNMENT_COMPLETE	The INS filter is in navigation mode, but not enough vehicle dynamics have been experienced for the system to be within specifications.
8	DETERMINING_ORIENTATION	INS is determining the IMU axis aligned with gravity.
9	WAITING_INITIALPOS	The INS filter has determined the IMU orientation and is awaiting an initial position estimate to begin the alignment process.
10	WAITING_AZIMUTH	The INS filter has orientation, initial biases, initial position and valid roll/pitch estimated. Will not proceed until initial azimuth is entered.
11	INITIALIZING_BIASES	The INS filter is estimating initial biases during the first 10 seconds of stationary data.
12	MOTION_DETECT	The INS filter has not completely aligned, but has detected motion.
14	WAITING_ALIGNMENTORIENTATION	The INS filter is waiting to start alignment until the current Vehicle Frame roll and pitch estimates are within the configured threshold of the expected orientation (set by the SETALIGNMENTORIENTATION command). Note: This requires an accurate RBV rotation to be configured, see the SETINSROTATION command.

3.5.1 System start-up and alignment techniques

The SPAN system requires an initial position, velocity and attitude estimate to start the navigation filter. This is called system alignment. On start-up, the system has no position, velocity or attitude information. When the system is first powered up, the following sequence of events happens:

1. The first satellites are tracked and coarse time is solved.
2. Enough satellites are tracked to compute a position.

1. The solution uncertainty threshold levels can be adjusted using the **INSTHRESHOLDS** command.

3. Receiver “fine time” is solved, meaning the time on board the receiver is accurate enough to begin timing IMU measurements.
4. The INS Status field changes from INS_INACTIVE through DETERMINING_ORIENTATION and WAITING_INITIALPOS.
5. Once a GNSS position is available, an initial IMU bias estimate is conducted. During this period, the INS Status field reports INITIALIZING_BIASES.
6. After the bias estimate is complete, the coarse alignment routine starts. Bias estimates will be refined and a static coarse alignment completed, if IMU quality allows. During this period the INS Status field reports INS_ALIGNING.
7. If static coarse alignment is not possible or is locked out by command, the system will require an external azimuth input, either from vehicle motion, dual antenna input or command input. While in this state the INS Status field reports WAITING_AZIMUTH.

If vehicle movement is detected, any ongoing static coarse alignment will be reset, and the INS Status field will report MOTION_DETECT.
8. After an alignment is completed, the INS Status field changes to INS_ALIGNMENT_COMPLETE. The system transitions to *Navigation mode* on page 107.
9. The solution is refined using updates from GNSS. Once the system starts estimating the IMU errors after some vehicle movement, the INS Status field will change to INS_SOLUTION_GOOD indicating INS solution has achieved a basic level of convergence. Note that it is advised to continue converging dynamics until the convergence flag is set to 1 in the Extended Solution Status word . This indicates that the INS filter has successfully converged to within performance specifications.

SPAN alignment methods

The following sections describe the different alignment routines available. By default, the first available method to align is used. Options for configuring a specific alignment methods are outlined below.

Static coarse alignment

The static coarse alignment is the default alignment routine for SPAN. The alignment starts automatically when a GNSS solution is available, the receiver has computed fine time, the IMU is connected and configured, and initial bias estimates have been completed. During the static coarse alignment, accelerometer and gyro measurements are averaged over a period of time to measure Earth rotation and gravity. From these averaged measurements, initial estimates of roll, pitch and heading are computed. Because the static coarse alignment uses averaged sensor output, the vehicle must remain stationary for the duration of the alignment, which is approximately 45 seconds. The attitude estimates solved by the alignment are larger than the system specified attitude accuracy and vary upon the characteristics of the sensor and the geographic latitude of the system. Attitude accuracy converges with motion after the coarse alignment is complete (see *Navigation mode* on page 107).



All **Grade 1** IMUs, as well as the HG4930 400Hz variant, and products that use these IMUs, cannot perform static coarse alignments, as these IMUs cannot accurately measure Earth rotation (see IMU Grade on the OEM7 Documentation Portal (docs.novatel.com/OEM7)). For these IMUs, the default alignment routine is kinematic alignment. Refer to *Kinematic alignment* on the next page. If a stationary alignment is required, refer to options for *Dual antenna alignment* on the next page, *NVM seeded alignment* on the next page, or *Manual alignment* on the next page.

Static Coarse alignments may be degraded due to environment, vibration or IMU age effects. Any error in initial alignment can cause performance issues.

Kinematic alignment

An alternate form of aligning the SPAN system is a kinematic alignment. A kinematic alignment can be used for any SPAN system and is the best alignment alternative for lower performance sensors (**Grade 1** IMUs, as well as the HG4930 400Hz variant, and products that use these IMUs). The kinematic or moving alignment is performed by estimating the heading from the GNSS velocity vector and injecting it into the SPAN filter as the initial system heading.

For the kinematic alignment routine to work optimally, the course-over-ground azimuth must not include any bias from the defined Vehicle Frame. (For example, a plane being blown in the wind has a large 'crab angle' and the course-over-ground trajectory will not match the direction the IMU is pointing.)

The rotation from the IMU Body frame to the Vehicle frame (RBV) must be set to enable kinematic alignment. In order to simplify this configuration it is strongly suggested that you mount the IMU in parallel to the vehicle frame. The Y axis marked on the IMU enclosure, should point in the direction of travel.

The kinematic alignment begins when the receiver has a good GNSS position, fine time is solved, the Body to Vehicle frame rotation is known and a GNSS velocity of at least 5 m/s (~ 18 km/h) is observed. For optimal performance, it is recommended to keep the vehicle fairly level during kinematic alignment.



5 m/s (~ 18 km/h) is the default alignment velocity. If a different alignment velocity is required, it can be changed using the **SETALIGNMENTVEL** command. Refer to the [OEM7 Commands and Logs Reference Manual](#) for more information.

While it is possible to lower the minimum speed required for kinematic alignment to take place, the higher the value, the more closely the course-over-ground estimate will match the vehicle heading.

The accuracy of the initial attitude of the system following the kinematic alignment varies and depends on the dynamics of the vehicle. The attitude accuracy will converge to within specifications once some motion is observed by the system. This transition can be observed by monitoring the INS Status field in the INS logs.

Dual antenna alignment

SPAN can also use heading information available from a NovAtel Dual Antenna ALIGN solution to rapidly perform an alignment. Refer to *SPAN with dual antenna* on page 139 for details.

NVM seeded alignment

SPAN can use the alignment information from a previous power up to quickly perform an alignment. For information about enabling and using an NVM Seeded Alignment, refer to *INS Seed / Fast INS initialization* on page 105.

Manual alignment

If the initial azimuth of the system is known, it can be entered manually using the **SETINITAZIMUTH** command. Refer to the [OEM7 Commands and Logs Reference Manual](#) for more information about this command.

A manual alignment should be used only if the azimuth is accurately known.

Configuring SPAN alignment method

The SPAN-enabled receiver can be configured for different alignment routines depending on the motion conditions experienced during the alignment period. For example, in marine applications, the dynamics required for either a static coarse or kinematic alignment cannot be guaranteed, so a different alignment routine will be required. This is achieved with the **ALIGNMENTMODE** command.

NVM Seeded alignment and Manual alignments are valid for all alignment modes and will supersede all other options if valid and available.

Automatic alignment mode (default)

The automatic alignment mode is the default setting for a SPAN-enabled receiver. This mode is designed to allow alignment of the system as quickly as possible, using any of the alignment methods (Static Coarse, Kinematic, NVM Seeded, Dual Antenna or Manual), regardless of its relative quality. No additional configuration is required to use this alignment routine. If a specific alignment technique is desired, it must be selected manually to guarantee that alignment method.

Unaided alignment mode

The unaided alignment mode sets the SPAN system to use only single antenna and superseding alignment options (Static Coarse, Kinematic, NVM Seeded or Manual alignment).

To use this alignment mode, the **ALIGNMENTMODE** command must be sent to the receiver.

```
ALIGNMENTMODE UNAIDED
```

Aided transfer alignment mode

The aided transfer alignment mode sets the SPAN system to use only dual antenna and superseding alignment options (Dual Antenna, NVM Seeded or Manual alignment).

This alignment routine is the preferred dual antenna alignment method.

If the vehicle is not stationary during the alignment, such as may be the case on a ship, use the Aided Transfer Alignment routine. This alignment method uses the ALIGN baseline solution to perform an instantaneous alignment of the vehicle azimuth.

The alignment happens instantaneously after the receiver establishes communication with the IMU and computes a verified, fixed integer, ALIGN solution.

To guarantee the use of this alignment mode, the **ALIGNMENTMODE** command must be sent to the receiver:

```
ALIGNMENTMODE AIDED_TRANSFER
```

Static coarse alignment mode

The static coarse alignment mode sets the SPAN system to use only static coarse and superseding alignment options (Static Coarse, NVM Seeded or Manual alignment).

To guarantee the use of this alignment mode, the **ALIGNMENTMODE** command be sent to the receiver:

```
ALIGNMENTMODE STATIC
```

Kinematic alignment mode

The kinematic alignment mode sets the SPAN system to use only kinematic and superseding alignment options (Kinematic, NVM Seeded or Manual alignment).

To guarantee the use of this alignment mode, the **ALIGNMENTMODE** command must be sent to the receiver:

```
ALIGNMENTMODE KINEMATIC
```

3.5.2 *INS Seed / Fast INS initialization*

The INS Seed functionality is an alignment method whereby INS alignment information from a previous power up can be injected into the system at start up to achieve an INS alignment more quickly. This is especially useful for systems that previously required a kinematic alignment.

When INS Seed is enabled, alignment data is automatically saved when appropriate, with no specific action required from the user. During subsequent power ups, the saved solution is compared to the current azimuth of the system, and if valid, the saved solution is used to immediately align the inertial filter, making it ready for use.

Error model information is also saved with the seed data. Even if full alignment cannot be achieved, this information can still be used to aid filter convergence, although another method of alignment will be required.

This feature is enabled via the **INSSEED** command. This command setting must be saved to NVM via the **SAVECONFIG** command to be used upon next system boot-up.

Criteria

For the INS seed functionality to be enabled, the **INSSEED ENABLE** command must be sent.

Saving

The following criteria must be met for valid alignment data to be saved into receiver NVM.

- The INS solution status must be converged, as indicated by the INS solution convergence flag in the inertial Extended Solution Status.
- The system is stationary.

When these conditions are met, the required information is automatically saved to NVM. If these conditions cease to be met, the saved alignment data is automatically discarded. If the alignment data is discarded, error model information is automatically retained as appropriate.

Use at boot-up

Upon boot, checks are done to verify that any seed data existing in NVM is appropriate for use. These checks require a GNSS position to be computed, so an NVM seed will never use the INJECTED status prior to achieving a GNSS position. The following criteria must be met in order to use a seed:

- Seed data from NVM must be valid
- The system must not have changed more than 10 degrees in heading

If the INJECT Error Model Option is selected, and a valid error model is present in the seed data from NVM, this will always be used, even if the system has exceeded attitude validation thresholds. This functionality may be disabled with the IGNORE Error Model Option

INJECT Option (Advanced Users Only)

There is an advanced option available to skip the second and third validation steps described in the boot-up section above. This can be used if GNSS is not available on power-up or if speed to achieve an alignment is imperative.

This option is for advanced users only. Forcing an injection of an NVM seed without the validation checks can cause an unstable INS solution if the vehicle has moved.

Apart from injecting the seed at start-up without validation, this will also remove some requirements typically asserted to allow the filter to converge. This will allow the system to run without GNSS adequately at start-up.

Example usage

Enabling functionality after FRESET:

1. Send the following command.

```
INSSEED ENABLE VALIDATE INJECT
```

2. Send the following command.

```
SAVECONFIG
```

Saving valid INS information:

1. Operate the system as normal, until the filter completes convergence.
2. Bring the system to a complete stop before powering off or resetting.

Using valid INS information on start-up:

1. Remain static while initializing.
2. Wait for the system to receive a valid position from GNSS.
3. If using ALIGN updates, INS Seed data will be validated and injected. If not, drive forward to validate and inject the INS Seed.

System indicators

The **INSSEEDSTATUS** log reports the seed injection status for the current power up and information on current seed validity. Refer the [OEM7 Commands and Logs Reference Manual](#) for more information about the **INSSEEDSTATUS** log.

The Extended Solution Status field in the **INSPVAX** log has bits that indicate if the alignment direction is verified, the Alignment type that occurred and NVM seed injection status.

Alignment direction verified: Bit 25

This bit indicates whether the alignment is verified or not. When the seed is injected and kinematic validation is finished, bit 25 is set to 1. Note that this bit will not be set until the kinematic validation completes. When the INJECT option is used, validation is skipped and this bit will not be set.

Alignment type: Bits 26-28

These bits indicate how the INS system reached INS_ALIGNMENT_COMPLETE. When the INS system aligns using saved INS solution data from NVM, bits 26-28 will be set to 101

NVM seed status: Bits 29-31

These bits indicate the current status of the seeding process at start-up, as described in the table below:

Table 27: NVM seed indication

Bit 31-29 values ¹	Hex value	NVM seed type
001	0x01	INS Seed in non-volatile memory is invalid
010	0x02	INS Seed has failed validation and has been discarded
011	0x03	INS Seed is pending validation
100	0x04	INS Seed alignment data has successfully been injected

3.5.3 Navigation mode

Once the alignment routine has successfully completed, SPAN enters navigation mode.

SPAN computes the solution by accumulating velocity and rotation increments from the IMU to generate position, velocity and attitude. SPAN models system errors by using a filter. The GNSS solution, phase observations and automatic zero velocity updates (ZUPTs) provide updates to the filter. Peripheral updates can also be supplied; wheel sensor for displacement updates or an external receiver for heading updates.

Following the alignment, the attitude is coarsely defined, especially in heading. Vehicle dynamics, specifically turns, stops and starts, allow the system to observe the heading error and allows the heading accuracy to converge. The amount of dynamics required for filter convergence vary by the alignment quality, IMU quality, and manoeuvres performed. The INS Status field changes to INS_SOLUTION_GOOD once convergence is complete. If the filter degrades in its system accuracy, the INS Status field changes to INS_HIGH_VARIANCE. When the accuracy converges again, the INS status continues as INS_SOLUTION_GOOD.

While in navigation mode (in firmware versions 7.09.00 or greater), SPAN operates an internal secondary INS filter for built-in redundancy and reliability. When a verified GNSS solution of sufficient quality is available, the primary and secondary filters are validated against the GNSS solution. If divergence between the primary filter and the GNSS solution is detected, SPAN position, velocity and attitude output will fall back to using the secondary filter solution. This allows the system to reinitialize the primary filter if the divergence cannot be recovered, without interruption to the system's position, velocity and attitude output. Once the primary INS filter returns to normal operation (through recovery or reinitialization), the INS solution will revert back to the primary filter.

The system will flag bit 22 of the INS Extended Solution Status (see the [OEM7 Commands and Logs Reference Manual](#)) to indicate whenever the secondary INS solution is in use.

3.5.4 Data collection

The INS solution is available in the INS-specific logs with either a standard or short header. Other parameters are available in the logs shown in *Table 28: Solution parameters* below:

Table 28: Solution parameters

Parameter	Logs	
Position	INSPOS or INSPOSS INSPVA or INSPVAS	INSPOSX or INSPVAX

1. The values from left to right are Bit 31, Bit 30 and Bit 29.

Parameter	Logs	
Velocity	INSVEL or INSVELS INSSPD or INSSPDS INSPVA or INSPVAS	INSVELX or INSPVAX
Attitude	INSATT or INSATTS INSPVA or INSPVAS	INSATTX or INSPVAX
Solution Uncertainty	INSSTDEV or INSSTDEVS	



The **INSATTX** log, **INSPOSX** log, **INSPVAX** log and **INSVELX** log contain solution and variance information and are therefore large logs. Use a low logging rate (<20 Hz) only. These logs also contain solution uncertainty in standard deviation format.

Note that the position, velocity and attitude are available together in the **INSPVA** log, **INSPVAS** log and **INSPVAX** log.

The inertial solution is available up to a rate of 200 Hz. Data can be requested at a specific synchronous time interval, asynchronously matching the IMU output rate, or can be triggered by the mark input trigger at rates up to 200 Hz.

The GNSS-only solution is still available through the GNSS-only logs such as RTKPOS and PSRPOS. Refer to the [OEM7 Commands and Logs Reference Manual](#). INS-only data logging and output can be at rates of up to the rate of the IMU data.



The highest rate that you should request GNSS logs (RANGE, BESTPOS, RTKPOS, PSRPOS, and so on) while in INS operation is 5 Hz. If the receiver is not running INS (no IMU is attached), GNSS logs can be requested at rates up to 20 Hz.



Logging restriction important notice

Logging excessive amounts of high rate data can overload the system. When configuring the output for SPAN, NovAtel recommends that only one high rate (>50 Hz) message be configured for output at a time. It is possible to log more than one message at high rates, but doing so could have negative impacts on the system. Also, if logging 100/200 Hz data, always use the binary format and, if possible, the short header binary format (available on most INS logs).

For optimal performance, log only one high rate output at a time. These logs could be:

- Raw data for post processing
RAWIMUXSB ONNEW (output rate depends on IMU see *Table 3: SPAN-compatible IMUs* on page 30)
 - RAWIMU logs are not valid with the ONTIME trigger. The raw IMU observations contained in these logs are sequential changes in velocity and rotation. As such, you can only use them for navigation if they are logged at their full rate. Refer to the [OEM7 Commands and Logs Reference Manual](#) for log and command details.
- Real time INS solution
IMURATEPVA ONNEW or IMURATEPVAS ONNEW
 - Other possible INS solution logs available at high rates are: INSPVASB, INSPOSSB, INSVELSB, INSATTSB

Specific logs need to be collected for post-processing. See *Data collection for post processing* on page 131.

To store data from an OEM7 receiver, connect the receiver to a computer running NovAtel Application Suite or other terminal program capable of recording data. On PwrPak7 receivers, you can also collect data on internal memory.

3.5.5 Recommended messages to be logged for SPAN data collection

Although every customer has a different application and setup, it is important to always log as much information about the GNSS and INS filters and the environment in which the survey is taking place. The following are the suggested messages that should be logged for every survey. Note that the list includes all necessary messages for post-processing in Inertial Explorer.

Recommended SPAN messages for OEM7

- LOG VERSIONB ONCHANGED
- LOG RXCONFIGB ONCE
- LOG RXSTATUSB ONCHANGED

- LOG RANGE B ONTIME 0.5
- LOG GPSEPHEMB ONALL¹
- LOG GLOEPHEMERISB ONALL²
- LOG GALFNAVEPHEMERISB ONALL³
- LOG GALINAVEPHEMERISB ONALL²

1. For firmware version earlier than 7.09.01, use the ONNEW trigger.

2. Should be logged if tracking GLONASS. For firmware version earlier than 7.09.01, use the ONNEW trigger.

3. Should be logged if tracking Galileo. For firmware version earlier than 7.09.01, use the ONNEW trigger.

- LOG BDSEPPHEMERISB ONALL¹
- LOG QZSSEPPHEMERISB ONALL²
- LOG NAVICEPPHEMERISB ONALL³
- LOG BESTGNSSPOSB ONTIME 1
- LOG BESTGNSSVELB ONTIME 1
- LOG BESTPOSB ONTIME 1
- LOG RANGE_B_1 ONTIME 0.5⁴

- LOG HEADING2B ONNEW⁶
- LOG RAWIMUSXB ONNEW
- LOG INSPVAXB ONTIME 1
- LOG INSCONFIGB ONCHANGED⁵
- LOG INSUPDATESTATUSB ONNEW
- LOG DMICONFIGB ONCHANGED⁶
- LOG RAWDMIB ONNEW⁸

3.5.6 Lever arm calibration routine

Each time the system is re-mounted on a vehicle, or the IMU or antenna is moved on the vehicle, the lever arm must be redefined either through manual measurement or through calibration.



We recommend that you measure the lever arm using survey methodology and equipment, for example, a total station. Only use calibrations when precise measurement of the lever arm is not possible.

Initial estimates and uncertainties for the lever arm may be entered using the **SETINSTRANSLATION ANT1** command. The calibration routine uses these values as the starting point for the lever arm computation.



The Lever Arm Calibration routine is not available for the OEM-HG1930, OEM-IMU-ADIS-16488, OEM-IMU-EG320N, OEM-IMU-EG370N, OEM-IMU-HG4930, OEM-IMU-STIM300, IMU-CPT, IMU-IGM-A1, IMU-IGM-S1, PwrPak7-E1, PwrPak7D-E1, PwrPak7-E2, PwrPak7D-E2, CPT7 or CPT7700.

The steps involved in the calibration are:

1. Should be logged If tracking BeiDou. For firmware version earlier than 7.09.01, use the ONNEW trigger.
2. Should be logged If tracking QZSS. For firmware version earlier than 7.09.01, use the ONNEW trigger.
3. Should be logged If tracking NavIC. For firmware version earlier than 7.09.01, use the ONNEW trigger.
4. Should be logged If using dual antennas.
5. Can change ONCHANGED to ONTIME 600 to ensure the message is recorded.
6. Should be logged if using DMI.

1. Apply power to the receiver and the IMU.
2. Configure the SPAN system, see *SPAN configuration* on page 87.
3. Enter the initial estimate for the lever arm using the **SETINSTRANSULATION ANT1** command.
Ensure the standard deviation values entered for the antenna offset are not overly optimistic (i.e., err on the side of a larger standard deviation).
4. Perform an initial system alignment using one of the methods described in *System start-up and alignment techniques* on page 101. Ensure the system reaches Solution Good.
5. Enable calibration using the **INSCALIBRATE** command with an optional standard deviation target. For example, choose a standard deviation target of 0.05 m.

```
INSCALIBRATE ANT1 NEW 0.05
```

6. To monitor the calibration, log **INSCALSTATUS** using the ONCHANGED trigger.
7. Start to move the system. The lever arm is not observable while the system is stationary. Immediately, drive a series of manoeuvres such as figure eights. The turns should alternate between directions, and you should make an equal number of turns in each direction. Some height variation in the route is also useful for providing observability in the Z-axis.
8. When the calibration is complete, either because the accuracy requirement has been met, or the calibration has been halted by user command, the calibrated offset value can be viewed in either the **INSCALSTATUS** log or the **INSCONFIG** log.

To save a calibrated lever arm for subsequent start ups, issue the **SAVECONFIG** command after calibration is complete. If the IMU or GNSS antenna are re-mounted, re-run the calibration routine to compute an accurate lever arm.



An accurate Lever Arm calibration depends on observability in all axes. Often, it can be very challenging to achieve sufficient dynamics during a calibration (e.g. a land vehicle can not normally achieve the same dynamics vertically as horizontally). To overcome this limitation, complete multiple calibrations and average the results (see also **INSCALIBRATE ADD** or do so manually). The calibrated values for axes with poor observability will likely have a large range of results not reflected in the final standard deviation value. Another method that may obtain a better result for these axes is to set the standard deviation target very low (i.e. 0.01) and run the calibration for a long time (at least 15 minutes). In this case, the calibration may not converge (reach CALIBRATED), but the convergence can be observed and a final value chosen appropriately.



For information about the logs and commands used in this procedure, refer to the [OEM7 Commands and Logs Reference Manual](#).

3.5.7 Body to vehicle frame rotation calibration routine

Kinematic alignment requires that the rotational offset between the vehicle and IMU Body frame (RBV) is known. If the angles are simple (that is, a simple rotation about one axis) the values can easily be entered manually through the **SETINSROTATION RBV** command. If the rotational offset is more complex (that is, rotation is about 2 or 3 axis), then the calibration routine provides a more accurate estimation of the values.

The steps for the calibration routine are:

1. Apply power to the receiver and IMU.
2. Configure the SPAN system including an approximate IMU Body to Vehicle frame (RBV) rotation. See *SPAN configuration* on page 87.
3. Ensure that an accurate lever arm has been entered into the system either manually or through a lever arm calibration, see *Lever arm calibration routine* on page 110.
4. Perform an initial system alignment using one of the methods described in *System start-up and alignment techniques* on page 101. Ensure the system reaches Solution Good.
5. Enable calibration using the **INSCALIBRATE** command with an optional standard deviation target.

```
INSCALIBRATE RBV NEW [target_stdev]
```

6. To monitor the calibration, log INSCALSTATUS using the ONCHANGED trigger.
7. Start to move the system. As with the lever arm calibration, movement of the system is required for the observation of the angular offsets.

Drive a straight course on level ground (remember that most roads have a crown resulting in a constant roll of a few degrees). Avoid driving on a surface with a constant, non-zero, slope to prevent biases in the computed angles. Vehicle speed must be greater than 5 m/s (18 km/hr) for the calibration to complete.

8. When the calibration is complete, either because the accuracy requirement has been met, or the calibration been stopped by user command (**INSCALIBRATE** command), the calibrated offset value is automatically applied can be viewed in either the **INSCALSTATUS** log or the **INSCONFIG** log.

To save a calibrated rotation for subsequent start ups, issue the **SAVECONFIG** command after calibration is complete. Each time the IMU is re-mounted this calibration should be performed again. See also *Static coarse alignment* on page 102 and *Kinematic alignment* on page 103 for details on coarse and kinematic alignment.



After the **INSCALIBRATE RBV ENABLE** command is entered, there are no body-vehicle rotation parameters present and a kinematic alignment is **NOT** possible. Therefore this command should only be entered after the system has performed either a static or kinematic alignment and has a valid INS solution.



As with the **SETINSROTATION** command, the minimum standard deviation that will be applied is 0.25 degrees (as viewed in the **INSCONFIG** log), even though the **INSCALSTATUS** log may report lower standard deviations after a successful calibration.



For information about the logs and commands used in this procedure, refer to the [OEM7 Commands and Logs Reference Manual](#).

3.5.8 Multi-line body to vehicle frame rotation calibration routine

The single pass Body to Vehicle frame offset calibration feature assumes flat ground when estimating the roll offsets between the IMU Body and Vehicle frames, as this component of the rotational offset is difficult to observe through typical ground vehicle motion. In practice this can result in an outstanding roll offset error as high as several degrees. For applications where vehicle roll must be well known, or pass-to-pass accuracy of a highly offset position is especially important, the Multi-Line IMU Body to Vehicle frame offset calibration routine offers higher calibrated accuracy in roll. This is done by running independent calibrations over the same

ground path in opposite directions; averaging the results cancels out the effect of any terrain induced roll. A minimum of two iterations are required. Additional iteration pairs can be executed for increased reliability.

Figure 26: Multi-line IMU body to vehicle calibration

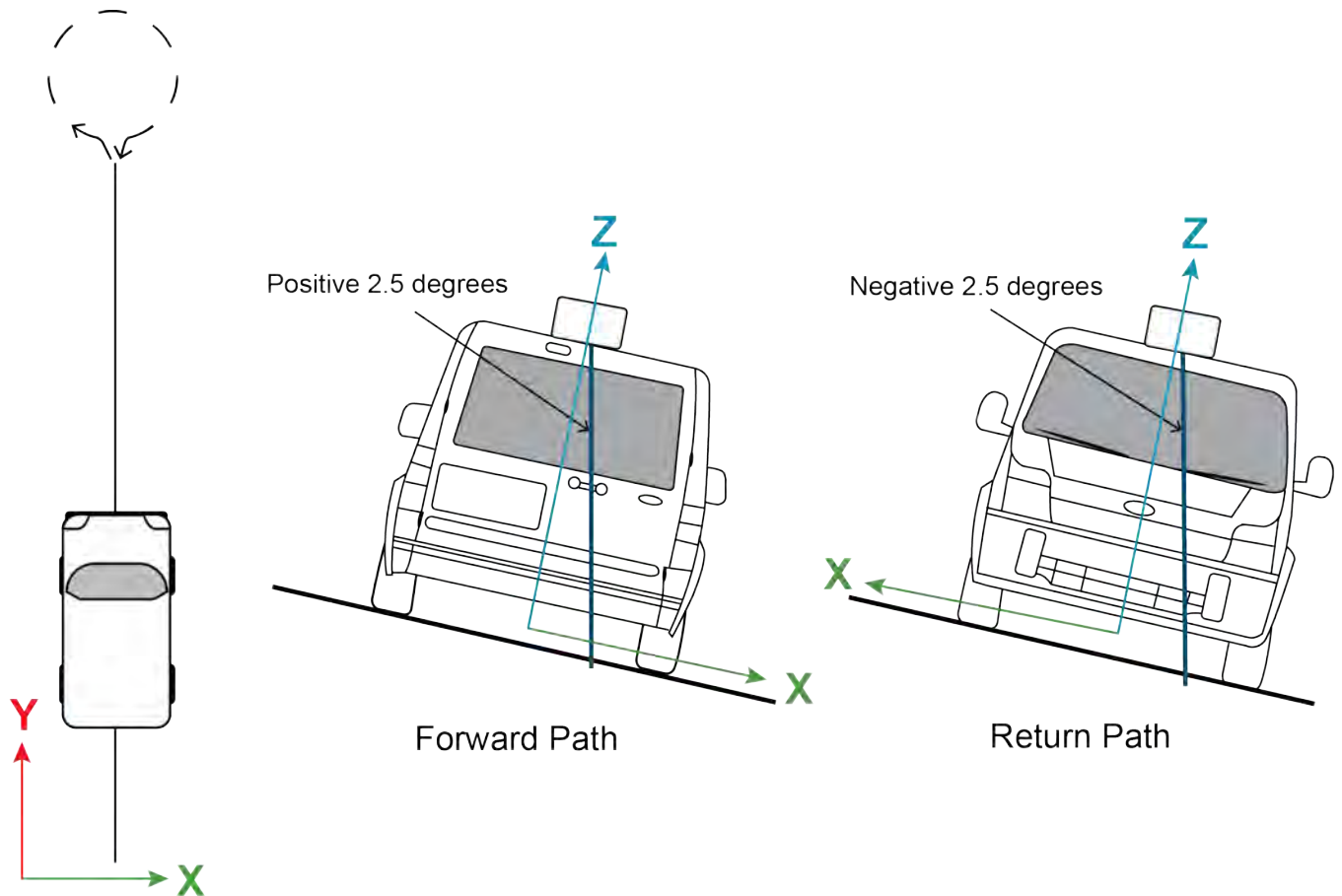

The steps for the calibration routine are:

1. Apply power to the receiver and IMU.
2. Configure the SPAN system, see *SPAN configuration* on page 87.
3. Ensure that an accurate lever arm has been entered into the system either manually or through a lever arm calibration, see *Lever arm calibration routine* on page 110.
4. Perform an initial system alignment using one of the methods described in *System start-up and alignment techniques* on page 101. Ensure the system reaches Solution Good.
5. Enable a new calibration using the **INSCALIBRATE** command, with the optional standard deviation target omitted:

```
INSCALIBRATE RBV NEW
```

6. Start to move the vehicle. Drive a straight course, at a vehicle speed greater than 5 m/s (18 km/hr). A distance of approximately 250 metres is recommended.

To monitor the calibration, log **INSCALSTATUS** using the ONCHANGED trigger.

7. When the end of the available distance is reached, stop the vehicle. Halt the ongoing calibration by sending the **INSCALIBRATE** command again:

```
INSCALIBRATE RBV STOP
```

8. At this point **INSCALSTATUS** will report a source status of CALIBRATED. Turn the vehicle around and come to a stop on the finishing point of the previous line.
9. Initiate the second pass of the calibration by issuing the **INSCALIBRATE** command with the **ADD** parameter:

```
INSCALIBRATE RBV ADD
```

10. Drive the vehicle back along the original course, until you reach the starting point for the first pass. Stop the vehicle, and re-issue the **INSCALIBRATE** command, with the **STOP** parameter. **INSCALSTATUS** will again indicate a source status of CALIBRATED.

At this point the Multi-Line calibration can be considered complete, but more iterations can be repeated until the desired accuracy level is reached.

At any point during an active calibration line, the **INSCALIBRATE** command, with the **RESET** parameter can be used to reset the calibration. This will ensure that the results of the active line are not added to the Multi-Line calibration. The **INSCALSTATUS** log will restore the previous source status and calibration values.

11. When the calibration is complete, the calibrated offset value can be viewed in either the **INSCALSTATUS** log or the **INSCONFIG** log.

To save a calibrated rotation for subsequent start ups, issue the **SAVECONFIG** command after calibration is complete. Each time the IMU is re-mounted this calibration should be performed again.



Do not start INS Calibrations (NEW or ADD) until the inertial alignment is completed and system has converged.



For information about the logs and commands used in this procedure, refer to the [OEM7 Commands and Logs Reference Manual](#).

3.6 Synchronizing external equipment

A SPAN system allows you to synchronize with external equipment.

All SPAN-enabled receivers accept input pulses (events). Each event signal can be configured for positive or negative polarity. Time, or a solution (position, velocity, attitude), can be generated and output with each input pulse.

3.6.1 Configuring an input strobe

SPAN systems have several input strobes. The input strobes apply an accurate GNSS time to the rising, or falling, edge of an input pulse called an event. For each event, an accurate position, velocity or attitude solution is also available. Each input strobe is usually associated with a separate device, therefore different solution output lever arm offsets can be applied to each strobe.

Each input strobe can be configured using the **EVENTINCONTROL** command for the following parameters:

Polarity:

When polarity is set to positive, events trigger on the rising edge. When polarity is set to negative, events trigger on the falling edge.

Time Bias (t_bias):

A constant time bias in nanoseconds can be applied to each event pulse. Typically this is used to account for a transmission delay.

Time Guard (t_guard):

The time guard specifies the minimum number of milliseconds between pulses. This is used to coarsely filter the input pulses.

The time of the input pulses is available from the **MARKTIME**, **MARK2TIME**, **MARK3TIME** and **MARK4TIME** log. The solution synchronous with the event pulses is available from the **MARK1PVA**, **MARK2PVA**, **MARK3PVA** and **MARK4PVA** log. The logs required for input strobes are:

LOG MARK1TIMEB ONNEW

Output time for every pulse received.

LOG MARK1PVAB ONNEW

Output time, position, velocity and attitude for every pulse received at the location specified by the **SETINSTRANSLATION** command and **SETINSROTATION** command.

The above example is for the MARK1 event input. The minimum detectable pulse duration must be greater than or equal to 1 microsecond.



The input signal levels are 3.3 V to 0 V. Signal voltages outside these bounds damage the receiver.



For information about the logs and commands used in this procedure, refer to the [OEM7 Commands and Logs Reference Manual](#).

3.7 Adding timed sensor triggers

Use the EVENT IN and EVENT OUT connections to attach up to three sensor devices to an OEM7 receiver and then trigger the sensors based upon GPS time.

In this context a 'sensor' is any external device. The 'sensor' reference in the receiver is an object consisting of an Event_In and Event_Out pair of system strobes all linked by a sensor identifier.

You can send multiple trigger events marked with a user-specified ID and a GPS time to trigger the sensor. At the requested trigger time, the receiver outputs a user-specified pulse to the sensor and waits for a response pulse to indicate a sensor measurement (i.e. camera exposure). When this response is received, the SPAN system outputs a log with the inertial position/velocity/attitude and the ID of the event.



For information about the EVENT IN and EVENT OUT signal levels, refer to the Strobe Specifications section in the [OEM7 Installation and Operation User Manual](#) or [PwrPak7 Installation and Operation User Manual](#).

3.7.1 Configuring the hardware

A sensor's trigger input is connected to a valid Event_Out and the sensor's response output is connected to a valid Event_In. Three sensor slots are available for use, but may be limited to less depending on the hardware platform used.

Table 29: Valid event inputs and outputs for timed sensor triggers

Valid event outputs	Valid event inputs
MARK1	MARK1
MARK2	MARK2
MARK3	MARK3
MARK4	MARK4

3.7.2 Configuring the software

Sensor objects are defined by using the **SETUPSENSOR** command. This command allows the Event_In and Event_Out lines to be specified as well as some parameters for the outgoing and incoming signals.



After configuring a sensor using the **SETUPSENSOR** command, any other commands that affect the selected event lines will disturb this functionality. For example, if MARK2 Out is selected for a sensor, but later the **EVENTOUTCONTROL** command is sent, the **EVENTOUTCONTROL** command will reconfigure the properties of the MARK2 line.

3.7.3 Using timed event pulses

When sensors have been connected and configured, use the **TIMEEVENTPULSE** command to queue events on the system. **TIMEEVENTPULSE** specifies the sensors that are affected, the GPS time for the desired event (in weeks and seconds), and an event ID. You can queue 10 unprocessed events at a time. Any time input specified via this command must occur at least 1 second after the command is entered.

The timing accuracy of the **TIMEEVENTPULSE** output is 2 milliseconds.

3.7.4 Recording incoming sensor events

After a **TIMEEVENTPULSE** is sent, the system can be configured to accept an incoming pulse from the sensor in order to produce a time and ID tagged inertial solution associated to that event. This is optional and useful if a sensor provides a measurement TOV pulse. The produced log is a TAGGEDxMARKPVA where the 'x' is the Event_In line associated with that sensor (via the **SETUPSENSOR** command).

For example, if the **SETUPSENSOR** command specifies SENSOR1 to use MARK1 in as the input event then a TAGGEDMARK1PVA log will be produced when any pulses on that line are observed. In this case the TAGGEDMARK1PVA log should be requested ONNEW to capture the data.

3.8 Distance Measurement Instrument

A Distance Measurement Instrument (DMI) can provide additional accuracy and reliability to a NovAtel SPAN solution. Specifically, a DMI can help constrain INS position and azimuth error growth during GNSS outages. The lower the IMU grade, the greater the DMI will help in constraining INS error drifts.

Typically, a DMI measures the distance travelled and represents the measurement using digital pulses. For a land vehicle, where a DMI is also known as a wheel sensor (odometer), the pulses are referred to as wheel ticks. If the pulses are accumulated and the size of the wheel known, a displacement of the wheel over time can be calculated. The SPAN system takes in a DMI input and applies a displacement update to the GNSS+INS Kalman filter in order to constrain the position error growth during GNSS outages. SPAN also

automatically estimates the size of the wheel to mitigate small changes in the size of the wheel due to hardware changes or environmental conditions.

A DMI with a higher accuracy will have more wheel ticks per revolution. For example, assume a wheel with a circumference of 2 metres and a DMI rated for 1000 ticks per revolution. The DMI will output 1000 pulses per complete revolution of the wheel. The resulting precision will be 0.002 m/tick. Given the same wheel, but a DMI rated for 10 ticks per revolution, the resulting precision will be 0.2 m/tick.

3.8.1 DMI communication

There are three methods a DMI can use to encode data.

- Pulse
This method uses a *single channel*, single-ended signal and is represented by A+. *Most NovAtel products require conversion to a differential signal.*
- Differential
This method uses a *single channel* with a pair of complementary signals represented as A+ and A-. Differential signals resist electromagnetic (EM) noise and improve robustness in challenging electrical environments compared to a single-ended pulse.
- Quadrature:
This method uses two channels, where there are two pairs of complementary signals represented as A+/A- and B+/B-. Each pair is offset with respect to one another by 90 degrees. The B signals provide directionality to the count measurements. By determining the directionality, this results in a more stable DMI update to the SPAN solution when compared to a single channel configuration. The differential pair improves robustness in challenging electrical environments.

Figure 27: Wheel sensor pulses (dual channel, quadrature, RS-422 differential)

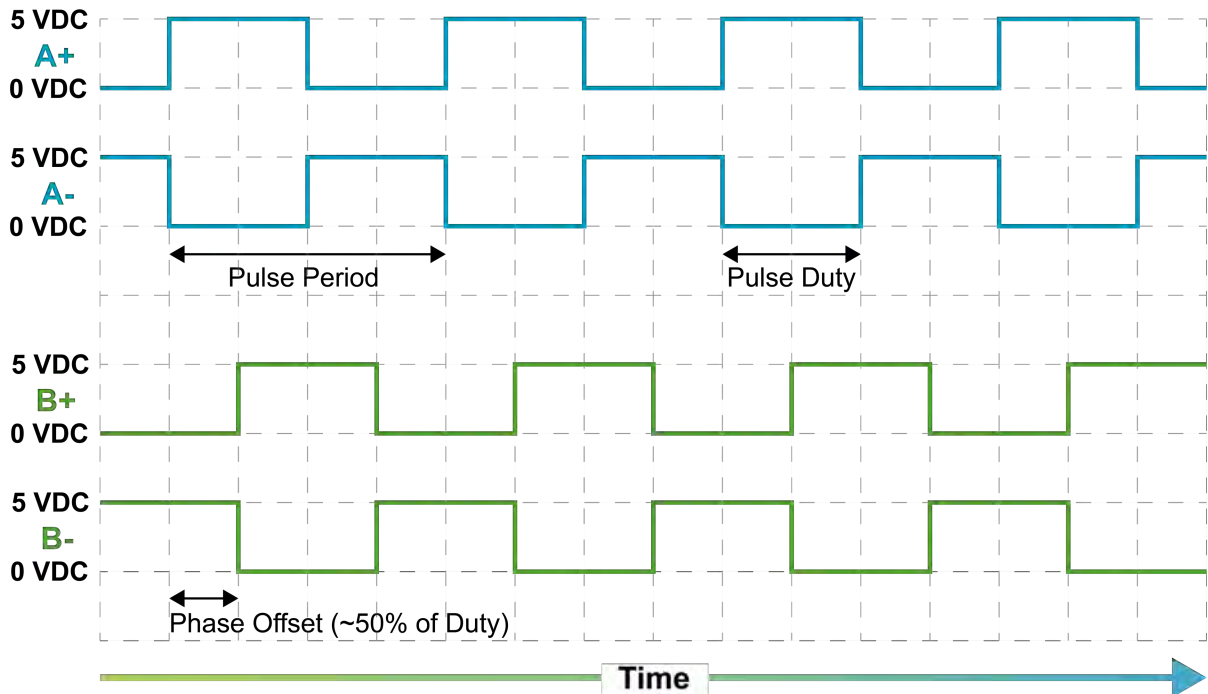

As quadrature encoding is a widely used DMI data transmission method, it is supported on most NovAtel SPAN-enabled products with DMI capability.

NovAtel SPAN-enabled products that support quadrature encoding also accept a single channel DMI input. In the case of a single channel, only the A+/A- differential wire pair is connected. A single channel

provides benefit to the SPAN solution by measuring only the distance travelled without regard for direction.



DMIs that use the Pulse or Differential method may use a separate direction signal or index signal. These additional signals are currently not supported directly, but may be used with an intermediate processor. The Pulse or Differential part of the interface may still be used directly.

3.8.2 DMI connection

Depending on the SPAN system components, the DMI can be connected to a PwrPak7, an IMU, a UIC or an intermediate processor.

- PwrPak7

For a SPAN system with a PwrPak7, the DMI can be connected to the HD26 COM PORTS connector on the PwrPak7.

For information about connecting and configuring a DMI connected to a PwrPak7, see *DMI connected to a PwrPak7* on page 120.

- IMU Enclosure

For a SPAN system with an IMU-HG1900, IMU-ISA-100C, IMU-LN200 or IMU- μ IMU-IC, the DMI can be connected to the Wheel Sensor port on the IMU enclosure.

For a SPAN system with an IMU-IGM-A1 or IMU-IGM-S1, the DMI is connected to the AUX port on the enclosure.

For a SPAN system with an IMU-FSAS or IMU-CPT, the DMI can be connected to the IMU connector. For information about connecting and configuring a DMI connected to an IMU, see *DMI connected to an IMU* on page 122.

- Universal IMU Controller (UIC)

For a SPAN system that uses a UIC to connect the IMU to the receiver, the DMI can be connected to the UIC.

For information about connecting and configuring a DMI connected to a UIC, see *DMI connected to a UIC* on page 124.

- Intermediate processor

NovAtel's OEM7 receiver cards do not handle DMI encoded signals natively. If using a receiver card, an intermediate processor is required to convert DMI pulses into NovAtel commands (RAWDMI).

For information about connecting and configuring a DMI connected using an intermediate processor, see *DMI connected to an intermediate processor* on page 126.

3.8.3 DMI requirements

The PwrPak7, UIC and certain IMU enclosures are compatible with any wheel sensor meeting the following requirements:

- Output signal duty cycle is symmetric 40% to 60%.
- Output signal voltage is RS-422 compliant (differential).
- The wheel sensor is powered externally. The receiver does not supply power to the wheel sensor.
- Quadrature, pulse and direction wheel sensors are compatible.
- Expected maximum pulse rate over measurement range does not exceed the product-dependent limit described in *Table 30: Wheel sensor maximum pulse rates* on the next page.

Table 30: Wheel sensor maximum pulse rates

Product	Maximum pulse rate
PwrPak7	100,000 Hz
MIC, UIC, IMU-H1900, IMU-IGM-A1, IMU-IGM-S1, IMU-ISA-100C, IMU-LN200, IMU- μ IMU-IC	300,000 Hz
IMU with direct wheel sensor support	See IMU documentation

An example of a compatible DMI is the Kistler Wheel Pulse Transducer CWPTA411 (WPT). See *Figure 28: Kistler WPT* below.

- A transducer traditionally fits to the outside of a non-drive wheel. A pulse is then generated from the transducer which is fed to the receiver.
- The WPT mounts to the wheel lug nuts via adjustable mounting collets. The torsion protection rod, which maintains rotation around the wheel axis, affixes to the vehicle body with suction cups. Refer to the Kistler WPT (part number CWPTA411) user manual for mounting instructions.

Figure 28: Kistler WPT

Kistler provides an M12 to DB9 cable for use with the WPT DMI. However, certain revisions of this cable do not bring through all four signal inputs. SPAN systems require at a minimum the A+ and A- signals for distance. All four signal inputs are required to measure both distance and direction correctly. See your WPT documentation for cable details.

Table 31: Kistler to NovAtel wheel sensor cable connections

Kistler cable		PwrPak7	IMU Enclosure		IMU-FSAS
M12 connector		All I/O Cable	M12 Connector on NovAtel cable		Female DB9
Pin	Signal	Wire label	Pin	Wire colour	Pin
Pin 1	GND	External	External		External
Pin 2	+U _B (Input Power)				
Pin 3	Signal A+	Wheel Sensor A+	Pin 1	White	Pin 6
Pin 4	Signal A-	Wheel Sensor A-	Pin 4	Yellow	Pin 7
Pin 5	Signal B+	Wheel Sensor B+	Pin 2	Brown	Pin 3
Pin 6	Signal B-	Wheel Sensor B-	Pin 5	Grey	Pin 1
Pin 7	Reserved	No connection	No connection		No connection
Pin 8					



This modification is for the Kistler WPT 8-pin M12-plug cable number 14865.



The WPT requires power to operate, which is not supplied through the receiver or IMU. Pins 1 and 2 should therefore be connected to an external power supply (+10 to +30 VDC).

3.8.4 DMI connected to a PwrPak7

A DMI can be used with any SPAN enabled PwrPak7 receiver. This includes PwrPak7 receivers with an internal IMU (such as a PwrPak7D-E1) or PwrPak7 receivers with an external IMU.



When using a PwrPak7 with an external IMU, the DMI can be connected to the PwrPak7 or the IMU. If connecting the DMI to the IMU, refer to *DMI connected to an IMU* on page 122.



The PwrPak7 can accept DMI data from only one DMI. If connecting the DMI to the PwrPak7, do not connect a second DMI to the external IMU.

Figure 29: DMI to PwrPak7 setup on the next page shows an overview of a DMI connected to a PwrPak7.

Figure 29: DMI to PwrPak7 setup

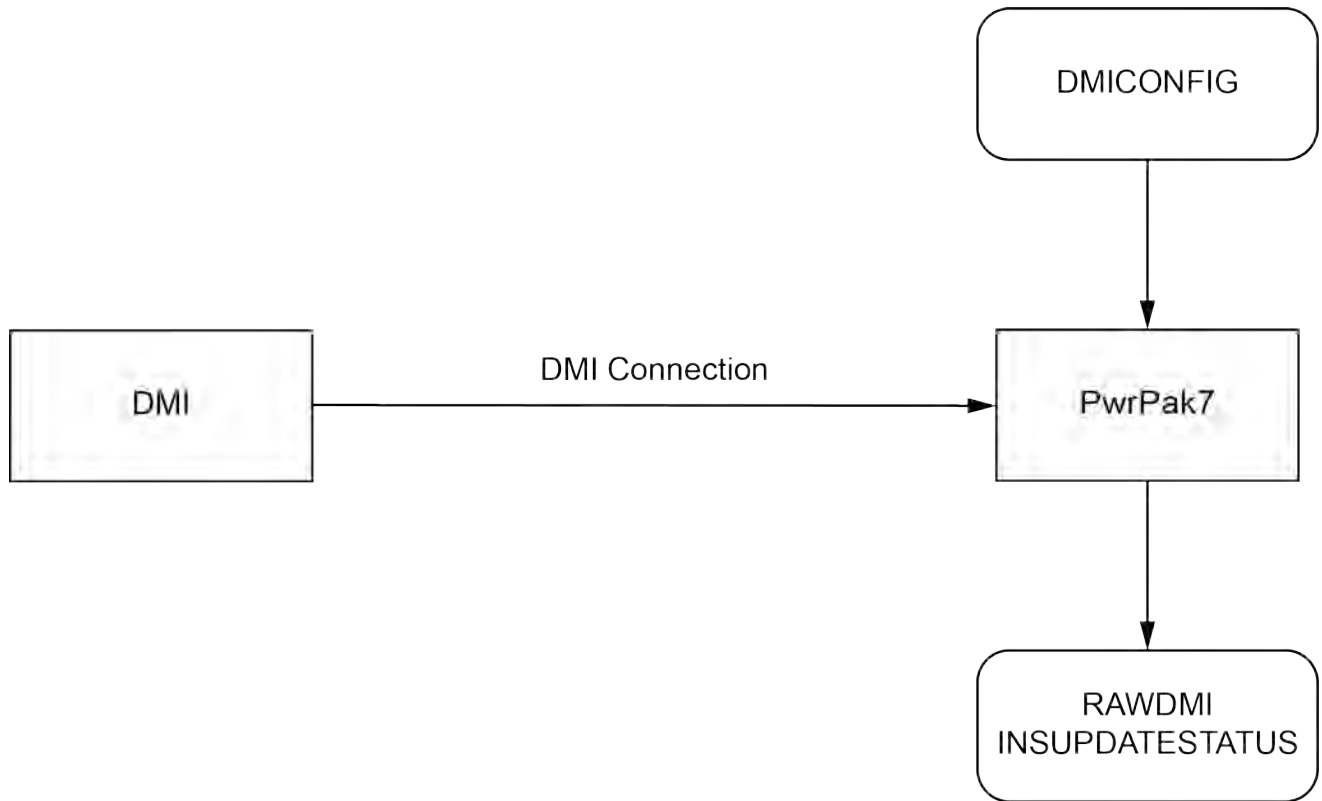

The DMI connections are A+, A-, B+, B- and GND for quadrature or A+, A- and GND for single channel.

DMI data collected on the PwrPak7

Typical DMI hardware generates wheel ticks constantly as the wheel rotates. The PwrPak7 interface is configured to accumulate wheel tick counts at a rate of 1 Hz.

DMI update logic

DMI data is available through the **RAWDMI** log. The **RAWDMI** log can be used for applying DMI updates in post-processing.

The SPAN filter uses sequential **RAWDMI** logs to compute a distance travelled between update intervals (1 Hz). This information is used to constrain free inertial drift during times of poor GNSS visibility. The filter also contains a state for modelling the circumference of the wheel as it may change due to hardware changes or environmental conditions.

Information about how the DMI updates are being used is available in the **INSUPDATESTATUS** log.

Connect the DMI to a PwrPak7

The PwrPak7 DMI inputs are RS-422 differential inputs. Refer to the [PwrPak7 Installation and Operation User Manual](#) for the required input voltages.

To connect a DMI:

1. Connect the PwrPak7 All I/O Cable, or custom interface cable, to the HD26 COM PORT connector on the PwrPak7.

For information about creating a custom interface cable, see the [PwrPak7 Installation and Operation User Manual](#).

2. Connect the wheel sensor wires on the interface cable to the DMI.

For a quadrature configuration, connect the DMI to the Wheel Sensor A+, Wheel Sensor A-, Wheel Sensor B+, Wheel Sensor B- and GND wires.

For a single channel configuration, connect the DMI to the Wheel Sensor A, Wheel Sensor A- and GND wires.

3. Connect an external power supply to the DMI.

The power required for the DMI depends on the DMI used. Refer to the DMI user documents for more information.

Configure a DMI

1. Send the following command to enable a DMI on the PwrPak7 wheel sensor inputs.

```
DMICONFIG DMI1 ENABLE ENCLOSURE
```

2. Send the following commands to log the DMI data.

```
LOG DMICONFIGA ONCHANGED
```

```
LOG RAWDMIA ONNEW
```

```
LOG INSUPDATESTATUSA ONNEW
```

3. Check the **RAWDMI** log to ensure the DMI is producing data.
4. Check the **INSUPDATESTATUS** log to ensure the DMI is being used in the SPAN solution.

If there is no DMI data being produced or the DMI status is not USED, refer to *DMI troubleshooting* on page 129.



For more information, see the **DMICONFIG** command, **RAWDMI** log and **INSUPDATESTATUS** log in the [OEM7 Commands and Logs Reference Manual](#).

3.8.5 DMI connected to an IMU

*Prior to configuring the DMI, configure the IMU with the **CONNECTIMU** command.*

A DMI can be connected to the following IMUs:

- IMU-ISA-100C
- IMU-LN200
- IMU-HG1900
- IMU- μ IMU-IC
- IMU-IGM-A1
- IMU-IGM-S1
- IMU-FSAS
- IMU-CPT

Figure 30: DMI to IMU setup on the next page shows an overview of a DMI connected to the IMU.

Figure 30: DMI to IMU setup

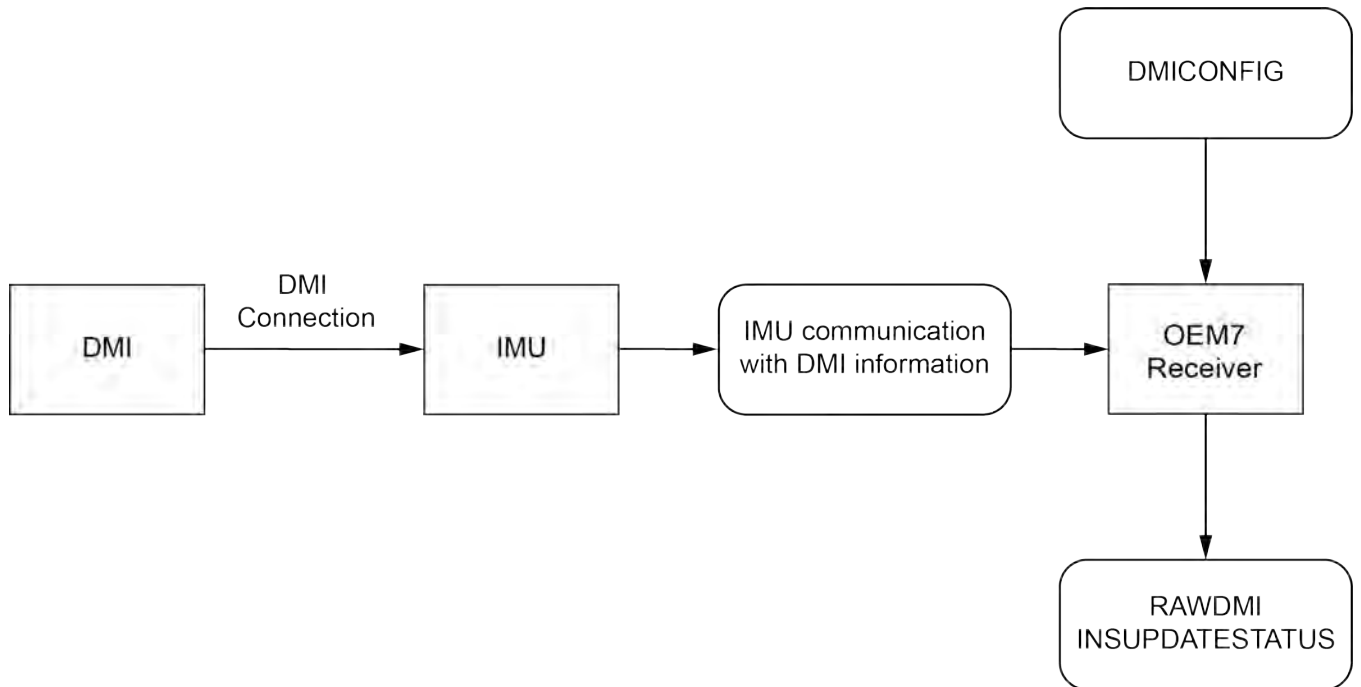

DMI data collected on IMU

Typical DMI hardware generates wheel ticks constantly as the wheel rotates. When a DMI is connected to the IMU, the wheel ticks are accumulated in the IMU. The accumulated wheel ticks, along with the raw IMU data, are sent the OEM7 receiver through the serial communication line.

DMI update logic

DMI data is available through the **RAWDMI** log. The **RAWDMI** log can be used for applying DMI updates in post-processing.

The SPAN filter uses sequential **RAWDMI** logs to compute a distance travelled between update intervals (1 Hz). This information is used to constrain free inertial drift during times of poor GNSS visibility. The filter also contains a state for modelling the circumference of the wheel as it may change due to hardware changes or environmental conditions.

Information about how the DMI updates are being used is available in the **INSUPDATESTATUS** log.

Connect the DMI to the IMU

All DMI compatible IMUs accept RS-422 differential signals from the DMI.



IMU-IGM-A1 and IMU-IGM-S1 accept TTL level input pulses from a DMI through the AUX connector.



The IMU-FSAS accepts signals from 2 V to 6 V.

To connect a DMI to the IMU:

1. Install the SPAN system using the instructions in *OEM7 receiver card installation* on page 33 or *PwrPak7 installation* on page 35.
2. Connect the wheel sensor to the IMU.
 - a. For the IMU-ISA-100C, IMU-HG1900, IMU-LN200 or IMU- μ IMU-IC, use the IMU Enclosure Wheel Sensor cable (60723137), or a custom cable, to connect the DMI to the Wheel Sensor port on the IMU. See *IMU Enclosure wheel sensor cable* on page 202 for information about the cable or for information about creating a custom wheel sensor cable.
 - b. For the IMU-IGM-A1 or IMU-IGM-S1, use a custom cable to connect the DMI to the AUX port on the IMU. Refer to *IMU-IGM-A1 and IMU-IGM-S1 ports* on page 186 for the pin out of the IMU-IGM AUX port.

The SPAN-IGM Auxiliary Port interface cable (01019015) can be used to connect the wheel sensor inputs to the IMU-IGM-A1 or IMU-IGM-S1. However, when this cable is used with an IMU-IGM-A1 or IMU-IGM-S1, only the wheel sensor inputs are available. The other connectors on this cable do not have connections to the IMU or receiver.
 - c. For the IMU-FSAS or IMU-CPT, connect the DMI to the wheel sensor inputs on the IMU interface cable. Use the IMU-FSAS Cable with Wheel Sensor or a custom cable that provides access to the wheel sensor inputs. See the *IMU-FSAS cable with wheel sensor* on page 175 for more information.
3. Connect an external power supply to the DMI.

The power required for the DMI depends on the DMI used. Refer to the DMI user documents for more information.

Configure the DMI

1. Send the following command to enable a DMI on the IMU wheel sensor inputs.

```
DMICONFIG DMI1 ENABLE IMU
```

2. Send the following commands to log the DMI data.

```
LOG DMICONFIGA ONCHANGED
```

```
LOG RAWDMIA ONNEW
```

```
LOG INSUPDATESTATUSA ONNEW
```

3. Check the **RAWDMI** log to ensure the DMI is producing data.
4. Check the **INSUPDATESTATUS** log to ensure the DMI is being used in the SPAN solution.

If there is no DMI data being produced or the DMI status is not USED, refer to *DMI troubleshooting* on page 129.

Refer to the [OEM7 Commands and Logs Reference Manual](#) for information about the commands and logs used in this section.

3.8.6 DMI connected to a UIC

When a UIC is used to connect one of the following IMUs to an OEM7 receiver, the UIC can also be used to connect a DMI to the SPAN system.

- OEM-IMU-ISA-100C
- OEM-IMU-LN200
- OEM-HG1900
- OEM-IMU- μ IMU-IC

Figure 31: DMI to UIC setup on the next page shows an overview of a DMI connected to the UIC.

Figure 31: DMI to UIC setup

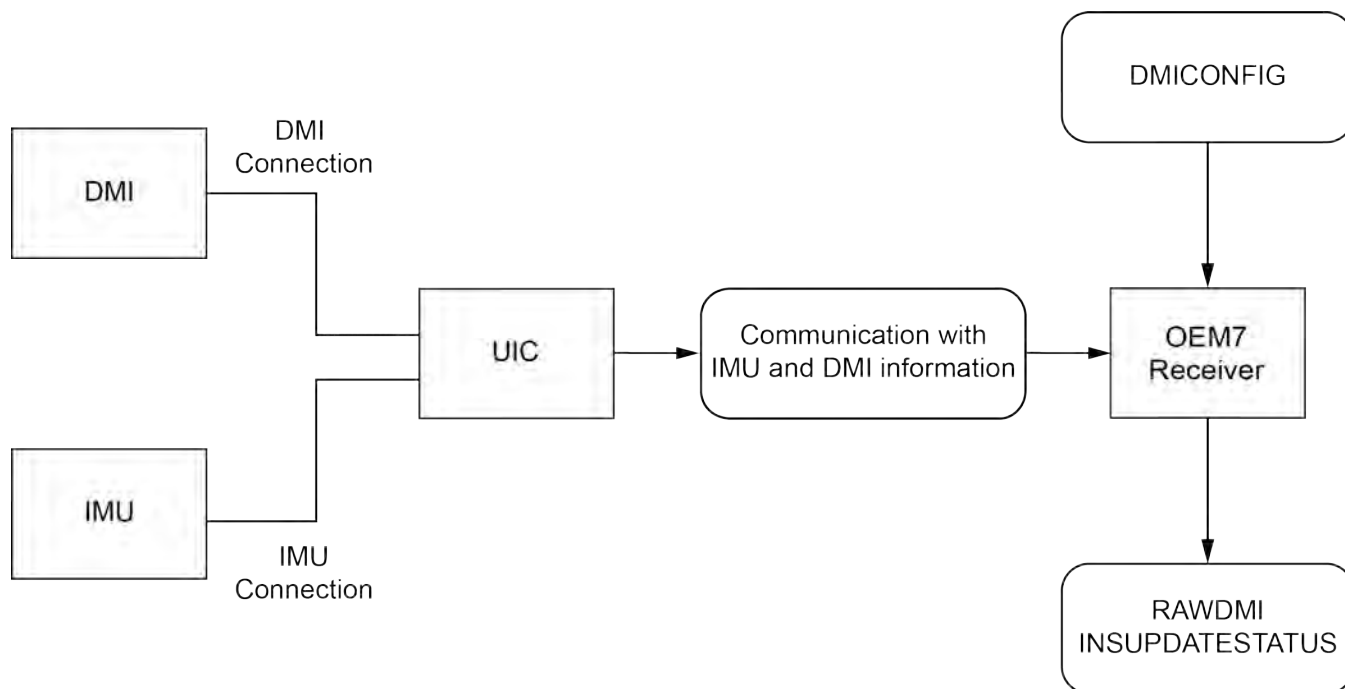

DMI data collected on UIC

Typical DMI hardware generates wheel ticks constantly as the wheel rotates. When a DMI is connected to the UIC, the wheel ticks are accumulated in the UIC. The accumulated wheel ticks, along with the raw data received from the IMU, are sent the OEM7 receiver through the serial communication line.

DMI update logic

DMI data is available through the **RAWDMI** log. The **RAWDMI** log can be used for applying DMI updates in post-processing.

The SPAN filter uses sequential **RAWDMI** logs to compute a distance travelled between update intervals (1 Hz). This information is used to constrain free inertial drift during times of poor GNSS visibility. The filter also contains a state for modelling the circumference of the wheel as it may change due to hardware changes or environmental conditions.

Information about how the DMI updates are being used is available in the **INSUPDATESTATUS** log.

Connect the DMI to the UIC

The UIC DMI inputs are RS-422 differential inputs. To connect a DMI to the UIC:

1. Install the SPAN system components using the instruction in *UIC installation* on page 71.
When creating the UIC cabling, ensure the wheel sensor inputs on the UIC Receiver Communications Connector (J102) are brought out to a separate connector or wire bundle.
2. Connect the DMI to the UIC wiring harness.
3. Connect an external power supply to the DMI.

The power required for the DMI depends on the DMI used. Refer to the DMI user documents for more information.

Configure the DMI

1. Send the following command to enable a DMI on the UIC wheel sensor inputs.

```
DMICONFIG DMI1 ENABLE IMU
```

2. Send the following commands to log the DMI data.

```
LOG DMICONFIGA ONCHANGED
```

```
LOG RAWDMIA ONNEW
```

```
LOG INSUPDATESTATUSA ONNEW
```

3. Check the **RAWDMI** log to ensure the DMI is producing data.

4. Check the **INSUPDATESTATUS** log to ensure the DMI is being used in the SPAN solution.

If there is no DMI data being produced or the DMI status is not USED, refer to *DMI troubleshooting* on page 129.

Refer to the [OEM7 Commands and Logs Reference Manual](#) for information about the commands and logs used in this section.

3.8.7 DMI connected to an intermediate processor

NovAtel's OEM7 receiver cards do not handle DMI encoded signals natively. If using a receiver card, an intermediate processor is required to convert DMI pulses into NovAtel commands (RAWDMI).

Figure 32: DMI through intermediate processor setup below shows an overview of a DMI connected to the receiver through an intermediate processor.

Figure 32: DMI through intermediate processor setup

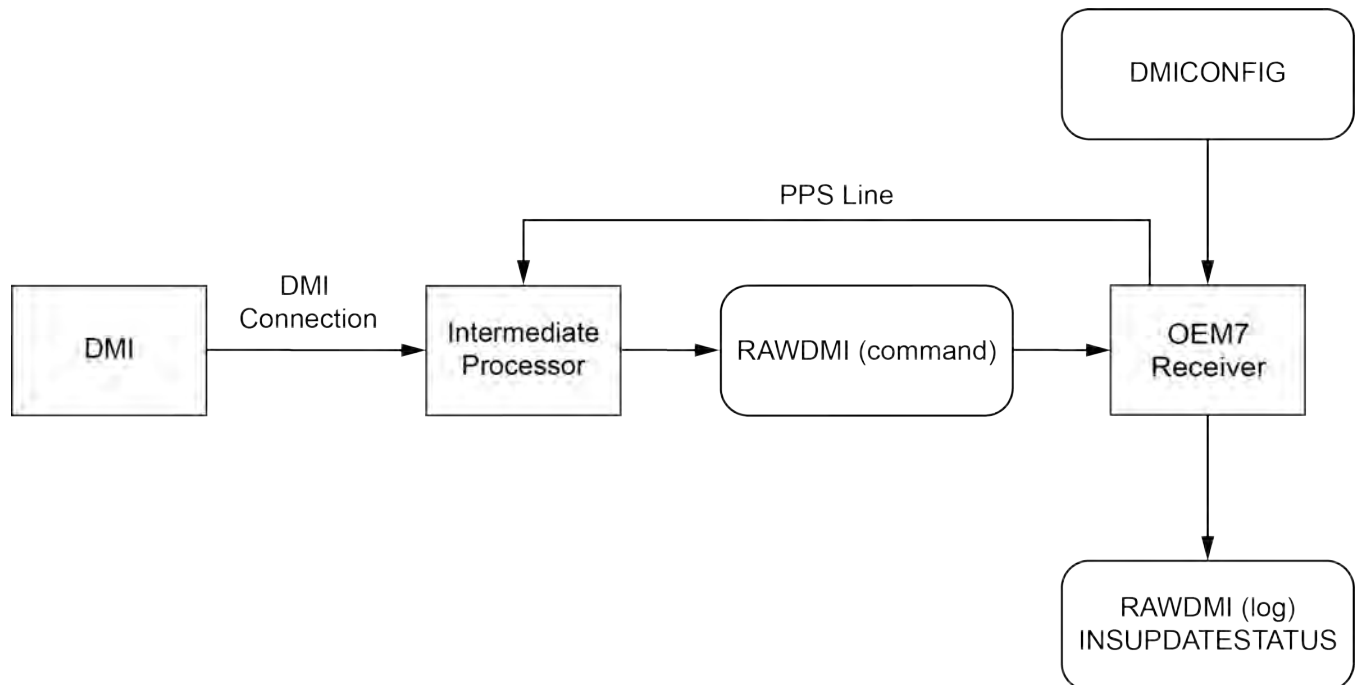

DMI data collected using an intermediate processor

Typical DMI hardware generates wheel ticks constantly as the wheel rotates. When using an intermediate processor, the wheel ticks are counted by the processor. The processor either accumulates the wheel ticks or uses the DMI data to calculate the current velocity. The count or velocity data is sent to the OEM7 receiver through a serial communication line using the **RAWDMI** command. The **RAWDMI** command should be periodic

at 1 Hz or faster, and ideally timed using the 1PPS output (or an appropriately configured EVENT_OUT output) from the receiver to ensure time synchronization of DMI measurements for optimal performance. A constant period is required for good performance.

DMI update logic

DMI data is available through the **RAWDMI** log. The **RAWDMI** log can be used for applying DMI updates in post-processing.

The SPAN filter uses sequential **RAWDMI** logs to compute a distance travelled between update intervals (1 Hz). This information is used to constrain free inertial drift during times of poor GNSS visibility. The filter also contains a state for modelling the circumference of the wheel as it may change due to hardware changes or environmental conditions.

Information about how the DMI updates are being used is available in the **INSUPDATESTATUS** log.

Connect the DMI to an intermediate processor

To connect a DMI:

1. Install the SPAN system components using the instructions in OEM7 Receiver Card Installation in the [OEM7 Installation and Operation User Manual](#).
2. Connect the DMI to the intermediate processor. Refer to the DMI and processor user documents for more information.
3. Connect the processor to one of the communication ports on the OEM7 receiver, like a serial port. Refer to Serial Ports in the [OEM7 Installation and Operation User Manual](#) for information about the receiver serial ports.
4. Connect the 1PPS or EVENT_OUT signal from the OEM7 receiver to an input on the intermediate processor if required. Refer to EVENT_IN, EVENT_OUT and PPS Signal Protection in the [OEM7 Installation and Operation User Manual](#) for information about connecting the 1PPS signal.
5. Connect an external power supply to the DMI.

The power required for the DMI depends on the DMI used. Refer to the DMI user documents for more information.

Configure the DMI

When using an intermediate processor, DMI data can be sent to the receiver as either accumulated wheel ticks or current velocity.

Send cumulative wheel ticks

The accumulated wheel ticks are sent from the intermediate processor to the OEM7 receiver using the **RAWDMI** command. This command must be sent at a constant rate (e.g. 1 Hz) and contain the cumulative number of wheel ticks accumulated since initialization. The Long value is allowed to roll over both directions (counting up and counting down). Sending of the **RAWDMI** command should be timed to the 1PPS signal from the receiver.

To configure the SPAN system to accept wheel ticks from an intermediate processor:

1. Send the following command to enable the DMI and set the expected input to wheel ticks.

```
DMICONFIG DMI1 ENABLE EXT_COUNT
```

2. Configure the intermediate processor to send a **RAWDMI** command to the OEM7 receiver at a constant rate. This command provides the number of wheel ticks accumulated since the last command.

In the following example, 1000 wheel ticks have been accumulated on DMI1 since initialization. In the subsequent two commands, 100 and 120 wheel ticks have been additionally accumulated, respectively.

```
RAWDMI 1000 0 0 0 1      sent at time t
RAWDMI 1100 0 0 0 1      sent at time t + 1s
RAWDMI 1220 0 0 0 1      sent at time t + 2s
```

3. Send the following commands to log the DMI data available in the receiver.

```
LOG DMICONFIGA ONCHANGED
LOG RAWDMIA ONNEW
LOG INSUPDATESTATUSA ONNEW
```

4. Check the **RAWDMI** log to ensure the DMI is producing data.
5. Check the **INSUPDATESTATUS** log to ensure the DMI is being used in the SPAN solution.

If there is no DMI data being produced or the DMI status is not USED, refer to *DMI troubleshooting* on the next page.

For information about the commands and logs used in this procedure, refer to the [OEM7 Commands and Logs Reference Manual](#).

Send current velocity

To send the current velocity to the OEM7 receiver, the intermediate processor must convert the DMI wheel ticks into a velocity. The velocity is then sent to the OEM7 receiver using the **RAWDMI** command. This command must be sent at a constant rate (e.g. 1Hz) and contain the current velocity for that update period. It is noted that the velocity mode is equivalent to sending the number of ticks counted only since the last command was sent, rather than a cumulative total as in the EXT_COUNT mode. Sending of the **RAWDMI** command should be timed to the 1PPS signal from the receiver.

To configure the SPAN system to accept wheel ticks from an intermediate processor:

1. Send the following command to enable a DMI on the UIC wheel sensor inputs.

```
DMICONFIG DMI1 ENABLE EXT_VELOCITY
```

2. Configure the intermediate processor to send a **RAWDMI** command to the OEM7 receiver once per update period. This command provides the current velocity for this update period.

Note, the **RAWDMI** value is a 32-bit signed integer representing the current velocity and should be scaled to the maximum precision per least significant bit (LSB). For example, if a velocity of 10 m/s is observed, and the precision of the measurement is to 0.01 m/s, then the measurement should be scaled by 100 (1/0.01) and the result would be an integer of 1000. The command for this example is:

```
RAWDMI 1000 0 0 0 1      sent at time t
```

In the same example, if a velocity of 10.01 m/s is observed in the next period, the resulting integer would be 1001.

```
RAWDMI 1001 0 0 0 1      sent at time t + 1s
```

3. Send the following commands to log the DMI data.

```
LOG DMICONFIGA ONCHANGED
LOG RAWDMIA ONNEW
LOG INSUPDATESTATUSA ONNEW
```

4. Check the **RAWDMI** log to ensure the DMI is producing data.
5. Check the **INSUPDATESTATUS** log to ensure the DMI is being used in the SPAN solution.

If there is no DMI data being produced or the DMI status is not USED, refer to *DMI troubleshooting* below.

For information about the commands and logs used in this procedure, refer to the [OEM7 Commands and Logs Reference Manual](#).

3.8.8 DMI command compatibility

With the introduction of the new streamlined command and log set for DMI use, legacy commands and logs have been deprecated.

Table 32: DMI command and log compatibility

Firmware 7.06.xx and earlier	Type	Firmware 7.07.00 and later	Type
WHEELVELOCITY ¹	Command	RAWDMI	Log/Command
TIMEDWHEELDATA	Log	RAWDMI	Log/Command
WHEELSIZE	Log	None	
INSWHEELUPDATE	Command	None	
SETWHEELPARAMETERS	Command	DMICONFIG	Command
ENCLOSUREWHEELSENSOR	Command	DMICONFIG	Command

For firmware versions 7.06.xx and earlier, refer to docs.novatel.com/OEM7/Content/Appendix/PreviousVersionsDocument.htm for information about the legacy commands and logs.

3.8.9 DMI troubleshooting

Confirming that a DMI is setup and communicating properly within the entire system is important. Once all the hardware is setup, and the necessary commands have been issued, use the following checklist to ensure that the DMI information is being created and used:

- **RAWDMI** logs are being published by the receiver.
- **RAWDMI** logs have valid data (when in motion the value in the RAWDMI log will increase).
- DMISTATUS in the **INSUPDATESTATUS** log reports a status greater than or equal to ACTIVE.

If there are no valid **RAWDMI** logs being published from the receiver then debugging the hardware connections and setup commands may be required. Check the following:

- All communication lines are connected to the DMI.
- The DMI is being powered.
- The receiver is being powered.
- The DMI has been enabled through a **DMICONFIG** command.
- The receiver has the latest NovAtel Firmware, available from the NovAtel website

1. The WHEELVELOCITY command will still be accepted in 7.07.00 and newer firmware with a limited capability. WHEELVELOCITY's cumulative tick field will be mapped to a RAWDMI command for backwards compatibility.

(novatel.com/support/support-materials/firmware-download).

- The receiver has a valid SPAN model for use with DMI.

Further electrical troubleshooting may be required to verify signal integrity. In many cases, note the following.

- Cable shields should be tied to the connector shells and the metallized backshells/housings should be in contact with the connector shells as well.
- A +/- and B +/- differential pairs should be on twisted pairs in the cables.



DMI input is not supported on Legacy CPT7 receivers (PN 80023560).

3.9 Azimuth sources on a SPAN system

The SPAN system use three different methods to calculate the azimuth.

- Course over ground
- Inertial azimuth
- ALIGN azimuth

3.9.1 Course over ground

The course over ground azimuth is determined using the position delta between two position solutions computed by the OEM7 receiver. This is the simplest way to compute an azimuth and is done using either the GNSS solution or the INS solution. This method does not work when the vehicle is stationary as any position difference is due to position error and the computed azimuth is meaningless.

Course over ground azimuth is of greatest advantage in aerial or marine environments where the actual direction of travel may not match the forward axis of the aircraft/boat due to winds or currents. This effect is known as the crab angle. Course over ground azimuth is a great way to compute the offset if another means of computing the vehicle azimuth is available.

Course over ground azimuths are available in several different velocity logs. See *Table 33: Logs with azimuth data* on the next page.

3.9.2 Inertial azimuth

The inertial azimuth computed by the SPAN inertial navigation filter. It uses the sensors in the IMU to compute the azimuth of the IMU (this can be rotated to another reference if desired). For more information, see the **SETINSROTATION** command in the [OEM7 Commands and Logs Reference Manual](#).

This azimuth is the one provided in the majority of the INS logs available to a SPAN user. See *Table 33: Logs with azimuth data* on the next page.

3.9.3 ALIGN azimuth

On SPAN systems with dual antennas, an azimuth is available from the dual antenna baseline. This is the same azimuth that is used as an update to the SPAN solution. It is noisier than the inertial azimuth and is available at a much lower rate, but will have a stable mean. This azimuth is computed from the base antenna to the rover antenna based on how the antennas are oriented on the vehicle.

There is a specific subset of logs that output this azimuth. See *Table 33: Logs with azimuth data* on the next page.

Table 33: Logs with azimuth data

Log	Log format	Azimuth source
BESTGNSSVEL	NovAtel	Course over ground From the best GNSS only solution
BESTVEL	NovAtel	Course over ground From the best system solution which could be either GNSS or INS
GPHDT	NMEA	ALIGN
GPVTG	NMEA	Course over ground From the best system solution which could be either GNSS or INS
HEADING2 / DUALANTENNAHEADING	NovAtel	ALIGN
INSATT / INSATTS / INSATTX	NovAtel	Inertial
INSPVA / INSPVAS / INSPVAX	NovAtel	Inertial
INSSPD	NovAtel	Course over ground Computed using the INS solution only
PASHR	NMEA	Inertial

3.10 Data collection for post processing

Some operations, such as aerial measurement systems, do not require real-time information from SPAN. These operations are able to generate the position, velocity or attitude solution post-mission in order to generate a more robust and accurate solution than is possible in real-time.

In order to generate a solution in post-processing, data must be simultaneously collected at a base station and each rover. The following logs must be collected in order to successfully post process data.

From a base:

- LOG VERSIONB ONCE
- LOG RXCONFIGB ONCE
- LOG RXSTATUSB ONCHANGED
- LOG THISANTENNA TYPEB ONCE
- LOG RANGECMPB ONTIME 1
- LOG RANGECMPB_1 ONTIME 1
- LOG GPSEPHEMB ONNEW
- LOG GLOEPHEMERISB ONNEW (if using GLONASS)
- LOG GALINAVEPHEMERISB ONNEW (if using Galileo)
- LOG GALFNAVEPHEMERISB ONNEW (if using Galileo)

- LOG BDSEPHMEMERISB ONNEW (if using BeiDou)
- LOG QZSSEPHMEMERISB ONNEW (if using QZSS)

From a rover:

- LOG VERSIONB ONCE
- LOG RXCONFIGB ONCE
- LOG RXSTATUSB ONCHANGED
- LOG THISANTENNATYPEB ONCE
- LOG HEADING2B ONNEW
- LOG INSCONFIGB ONCHANGED
- LOG RANGECMPB ONTIME 1
- LOG GPSEPHEMB ONNEW
- LOG GLOEPHEMERISB ONNEW (if using GLONASS)
- LOG GALINAVEPHEMERISB ONNEW (if using Galileo)
- LOG GALFNAVEPHEMERISB ONNEW (if using Galileo)
- LOG BDSEPHMEMERISB ONNEW (if using BeiDou)
- LOG QZSSEPHMEMERISB ONNEW (if using QZSS)
- LOG RAWIMUSXB ONNEW
- LOG TIMEB ONTIME 1
- LOG BESTPOSB ONTIME 1
- LOG BESTGNSSPOSB ONTIME 1
- LOG INSPVAXB ONTIME 1
- LOG INSUPDATESTATUSB ONCHANGED
- LOG DMICONFIGB ONCHANGED (if using a DMI sensor)
- LOG RAWDMIB ONNEW (if using a DMI sensor)

Post processing is performed using Waypoint Inertial Explorer. Visit our web site at novatel.com/products/waypoint-software for details.



The highest rate that you should request GNSS logs (RANGE, BESTPOS, RTKPOS, PSRPOS, and so on) while in INS operation is 5 Hz. If the receiver is not running INS (no IMU is attached), GNSS logs can be requested at rates up to 20 Hz.



The choice between ONNEW and ONCHANGED is dependent on the type of data collection and user preferences. The ONNEW trigger can result in larger files with duplicate logs that are ignored by Inertial Explorer's converter. The ONCHANGED trigger is preferable to avoid duplicates and minimize file size. However, if the ONCHANGED log request is made before the logging file is opened the log will not be triggered until a value has changed. This may cause issues in short surveys, as slow changing logs (such as RAWEPHEMB) may not be logged during the data collection period. For this reason, ONNEW is suggested for short surveys.



No RAWDMIB logs will be decoded without the presence of a DMICONFIGB log. As such, users may consider logging this ONTIME at a coarse rate to ensure it is saved to file (e.g. LOG DMICONFIGB ONTIME 300).

3.11 Firmware updates and model upgrades

Firmware updates are firmware releases which include fixes and enhancements to the receiver functionality. Firmware updates are released on the web site as they become available.

Model upgrades enable features on the receiver and may be purchased through NovAtel authorized dealers.

Contact your local NovAtel dealer first for more information. To locate a dealer in your area visit Where to Buy | Dealer Network on the NovAtel web site at novatel.com/contactus/sales-offices or contact NovAtel Customer Support directly.

For information about how to install firmware updates or model upgrades, refer to the [OEM7 Installation and Operation User Manual](#).

3.12 Variable Lever Arm

The variable lever arm concept arose to support applications in which the IMU is no longer rigidly fixed to the vehicle, but rather on a gimballed mount. This creates an issue where the input lever arm offsets to the GNSS antenna are no longer correct, because the IMU can rotate on its mount, while the antenna remains fixed.

The use of the variable lever arm functionality requires that the device to which the IMU is attached be able to send its gimbal rotation angles back to SPAN. These angles are used to recalculate the lever arm at the rate that they are received. SPAN will also be able to output a gimballed solution at the rate the gimbal angles are received.

3.12.1 Reference frame description

There are several frames of reference involved when dealing with a gimballed mount. The frames are all very similar, but can be quite confusing due to small differences. Below are all frames applicable to the implementation of the variable lever arm:

Frame	Description	Notation
IMU Body frame	The physical IMU axes	(b)
Vehicle frame	Default reference frame for attitude output in SPAN logs	(v)
Mount body frame	The physical axes of the gimballed mount	(m)
Gimbal body frame	The physical axes of the gimbal plane. This frame matches the mount body frame when gimbal angles are zero and rotates relative to the mount body frame when the gimbal is active.	(g)

Frame	Description	Notation
User Output Frame	An arbitrary frame, used to define the desired reference for attitude output, typically matching a gimbal mounted sensor	(ou)
Mark Output Frame	An arbitrary frame, used to define the desired reference for attitude output for the MARKxPVA logs, typically matching a gimbal mounted sensor	(om)

3.12.2 Example gimbal installation

Figure 33: Sample configuration below and Figure 34: Operating gimbal on the next page illustrate a basic scenario for the information in the table above. Figure 33: Sample configuration below shows a possible configuration for the mount body frame, IMU body frame and a user output frame, with the gimbal in a locked position. The extra rotation commands required to configure Variable Lever Arm for this setup are:

```
SETINSROTATION RBM 180 0 0
SETINSROTATION USER 0 0 90
SETINSROTATION RBV 0 0 -90
```

Figure 34: Operating gimbal on the next page shows the gimbal in operation; the gimbal platform has moved relative to the mount body frame. The gimbal frame and IMU Body frame move together, as does the user output (or mark output) frame.

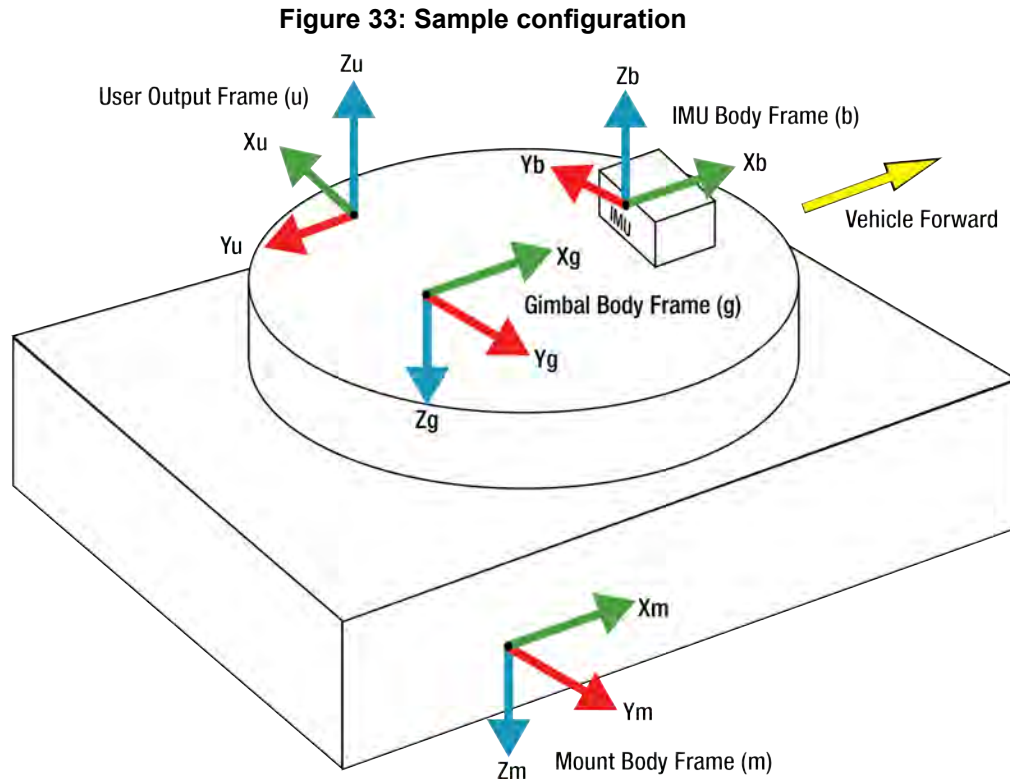
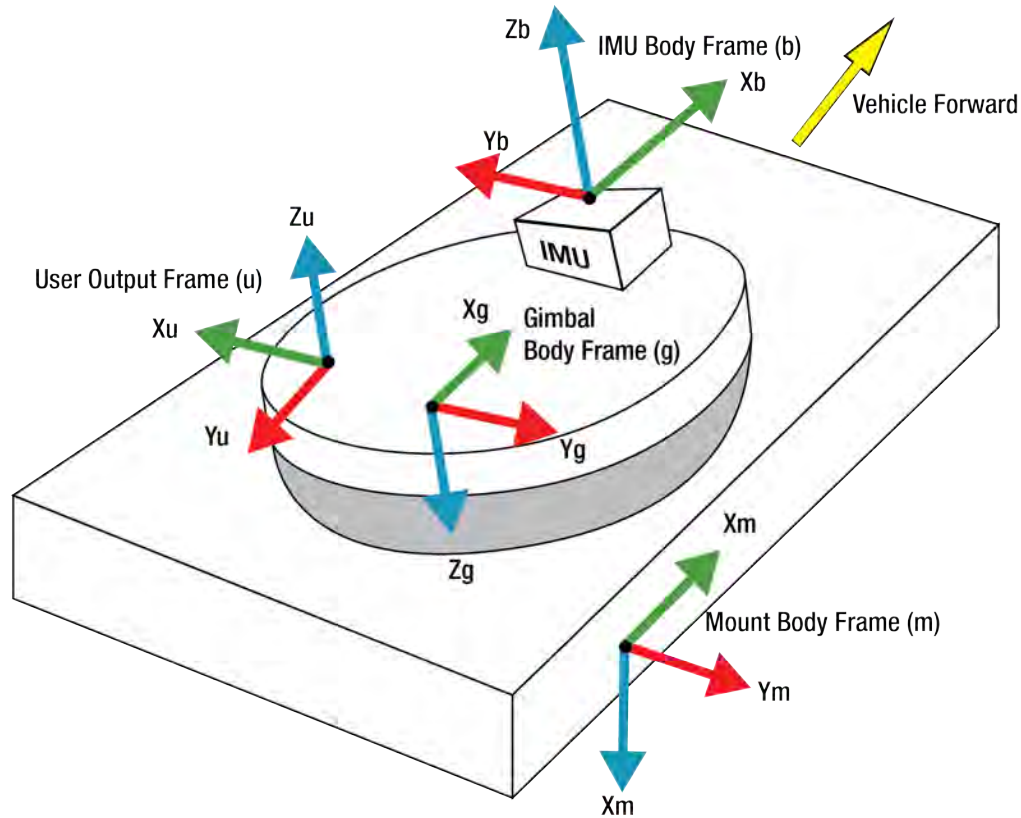

Figure 34: Operating gimbal



3.12.3 How to use Variable Lever Arm

The variable lever arm functionality requires the input of gimbal angles from a rotating camera mount or gimbal platform, on which a SPAN IMU is mounted. With input gimbal angles and the correct configuration, the SPAN system will compute a variable lever arm offset and produce gimbal-corrected messages.

Ensuring a proper variable lever arm is important for SPAN performance.

Basic I/O

The variable lever arm functionality is based on the input of the **INPUTGIMBALANGLE** command. This command specifies the right-handed rotation angles from the **mount body frame (m)** to the **gimbal body frame (g)**, with the order of rotations Z-X-Y. Entering this command will automatically cause the system to rotate the static lever arm into the latest gimballed frame. The update rate of the variable lever arm depends on the rate of the gimbal commands which can be entered at 1 to 50 Hz. If an **INPUTGIMBALANGLE** command is not received for over 1 second then the system will return to using the static lever arm.

In addition to using the variable lever arm internally, the following information is available to the user.

Table 34: Logs used with Variable Lever Arm

Log	Description
VARIABLELEVERARM	This log contains the re-calculated primary antenna (ANT1) translation offsets adjusted for the rotation defined by the INPUTGIMBALANGLE command. The VARIABLELEVERARM log is output in the IMU Body frame.

Log	Description
GIMBALLEDPVA	This log contains the INS position, velocity, and attitude rotated back into the gimbal null position. When the gimbal mount is in the zero/locked position, the GIMBALLEDPVA output will match the INSPVA log. The position and velocity is output at the IMU centre of navigation, unless a user output frame is defined (configured with the SETINSTRANSULATION command). The attitude is output in the user output frame (configured with the SETINSROTATION command, default is Vehicle frame).
INSPVA, INSPVAS, INSPVAX	The INSPVA log is synchronous so does not depend on the entry of the INPUTGIMBALANGLE command. However when the gimbal angles are non-zero, the INSPVA log no longer represents the orientation of the gimbal mount / vehicle, but rather the current orientation of the unlocked gimbal platform. If the orientation of the vehicle is important, use the GIMBALLEDPVA log.

Rotations and translations

For the information provided by the system to be meaningful, the following offsets have to be set correctly. By default the system assumes that the IMU Body frame, gimbal mount and Mount Body frame are coincident. If this is not the case then additional commands are necessary to relate all of the different frames together using the commands below. If attitude output is desired relative to an external camera, this can also be configured using these commands.



When entering the **SETINSROTATION** commands described in the following table, the gimbal mount should be locked (**INPUTGIMBALANGLE** rotations are zero).

Table 35: Commands used with Variable Lever Arm

Command	Purpose
SETINSROTATION RBV	This command provides the orientation of the IMU Body frame while the gimbal frame is in the locked null position. This is required information before the SPAN system can complete an inertial alignment. The SETINSROTATION RBV command relates the IMU Body frame (b) to the Vehicle frame (v). Once an RBV rotation has been provided, default attitude output will be referenced to the Vehicle frame.
SETINSROTATION RBM	This command relates the IMU Body frame (b) to the Mount Body frame (m). This information is required for interpreting the rotation angles from the INPUTGIMBALANGLE command correctly.
SETINSROTATION USER	By default, attitude information output by SPAN is for the vehicle frame. If attitude output is required to be referenced to another frame (typically the axes of a gimbal-mounted sensor), the USER offset can be used to rotate the attitude output in general SPAN logs to this frame.
SETINSROTATION MARKx	Similar to the user rotation, this rotation can be used to change the attitude output reference frame for the MARKxPVA logs.
SETINSTRANSULATION GIMBAL	This command provides the translation offset from the IMU centre of navigation to the gimbal mount centre of rotation, used for proper variable lever arm computations.

3.13 Relative INS

NovAtel's Relative INS technology generates a position, velocity and full attitude vector between two SPAN systems. One is the Base receiver and the other is the Rover receiver. Once configured, the Base receiver begins transmitting corrections to the Rover receiver. Relative information is created and the system begins filling the **RELINSPVA** log and **SYNCRELINSPVA** log on the Rover receiver. The **RELINSPVA** log is then transmitted back to the Base receiver for output.

The data link required must be able to support [864bits+108bits x #obs tracked per second]. The **RELINSPVA** log is requested **ONNEW** (available from 1Hz-20Hz depending on the setup of the **RELINSAUTOMATION** command) while the **SYNCRELINSPVA** log can be requested **ONTIME** at up to 200Hz (at the rover only). Position and velocity solutions are differenced in the ECEF frame and then rotated into the local level. The Relative offset vector that is output is dependent on Base/Rover's precise RTK vector and their eccentric offset vectors (optional offset provided using the **USER** parameter in the **SETINSTRANSLATION** command), shown in *Figure 35: Relative INS example* below.

Figure 35: Relative INS example

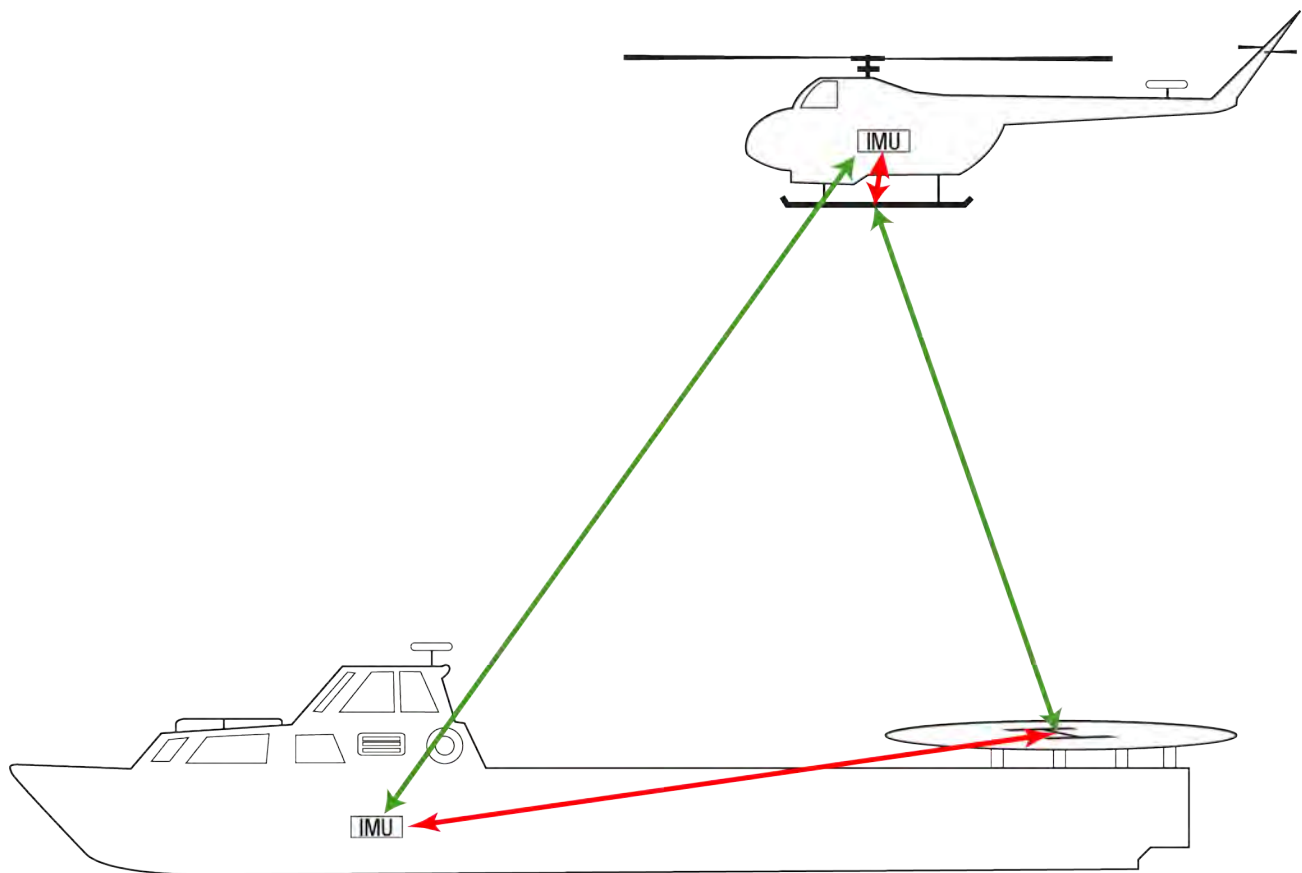

An important command that can be used with Relative INS to manually change the maximum amount of time to use RTK data is the **RTKTIMEOUT** command. This command is used to set the maximum age of RTK data to use when operating as a rover station. RTK data received that is older than the specified time is ignored. The default is 60 seconds, however when using Relative INS, it is suggested this be set to 5 seconds by sending the command **RTKTIMEOUT 5**.



For information about the **RTKTIMEOUT** command, refer to the [OEM7 Commands and Logs Reference Manual](#).

3.13.1 *Configure Relative INS*

To configure the receivers to begin computing the relative information:

1. Setup a link between the receivers that will be used to transfer data (for example, radios).
2. Enable the transfer of relative corrections between receivers using one of the methods below.
 - Send the **RELINSAUTOMATION** command only at the Rover receiver
 - Send the **RELINSCONFIG** command at both the Base and Rover receiver



To configure Relative INS using the **RELINSAUTOMATION** command, the base and rover receivers must be communicating using a COM port. If the base and rover are communicating via an ICOM port, the **RELINSCONFIG** command must be used.



The base and rover receiver must be using the same datum.

Chapter 4 SPAN with dual antenna

NovAtel's ALIGN heading technology generates distance and bearing information between a “base” and one or more “rover” receivers.

SPAN with Dual Antenna provides the hardware necessary to run an ALIGN baseline with an IMU and a second receiver.

With SPAN, the ALIGN GNSS baseline can be used to assist the initial alignment of the SPAN solution. In addition, the ALIGN baseline solution will aid the heading solution from the receiver if the heading drifts due to slow or constant dynamics.

ALIGN is capable of a 10 Hz heading output rate when integrated with the OEM7 receiver.



For optimal performance of Dual Antenna with SPAN, refer to the configuration details described in *Configuring dual antenna ALIGN with SPAN* on page 141.

4.1 Installation

The hardware for SPAN with Dual Antenna is installed in a manner similar to other SPAN systems. Some points to consider during your installation are:

1. Install the IMU and the two antennas in the vehicle such that the relative distance between them is fixed.
2. The antennas should be mounted with as clear a view of the sky as possible so each satellite above the horizon can be tracked with minimal obstruction. If using a dual antenna system, the GNSS ALIGN accuracy is dependent on antenna baseline length; hence mount the primary and secondary antennas as far apart as possible (a minimum separation distance of 1 metre is recommended).

In most scenarios, it is ideal to use the antenna closest to the IMU as the primary. However, it may be use case dependent given the installation location of both antennas.

For more information, refer to the [OEM7 Installation and Operation User Manual](#).

3. The lever arms or distance from the IMU to the antennas needs to be fixed and accurately measured using the coordinate axes defined on the outside of the IMU. The baseline between the two antennas does NOT need to be aligned with the vehicle axes or with the axes of the IMU.
4. Both receivers need to be powered and connected to each other via COM 2 before sending any configuration commands. It does not matter which receiver is powered on first, or how long they are both powered before sending any commands.



SPAN with Dual Antenna operation assumes the use of the COM 2 port for communication between receivers unless a different port is specified using the **INSALIGNCONFIG** command. This command can change the COM ports of the SPAN-enabled base and the rover, the baud rate used and data output rates.



For information about connecting the ALIGN base and rover receivers using a port that is not a serial COM port (e.g. Ethernet), contact NovAtel Customer Support.

The two receivers need to be set up as shown in the example in *Figure 36: SPAN – two receiver dual antenna installation* below.

Dual antenna receivers, such as the OEM7720 and PwrPak7D, contain the hardware necessary to provide an ALIGN solution without an additional receiver. Set up a SPAN system with a dual antenna receiver as shown in *Figure 37: SPAN – single receiver dual antenna installation* on the next page.

Figure 36: SPAN – two receiver dual antenna installation

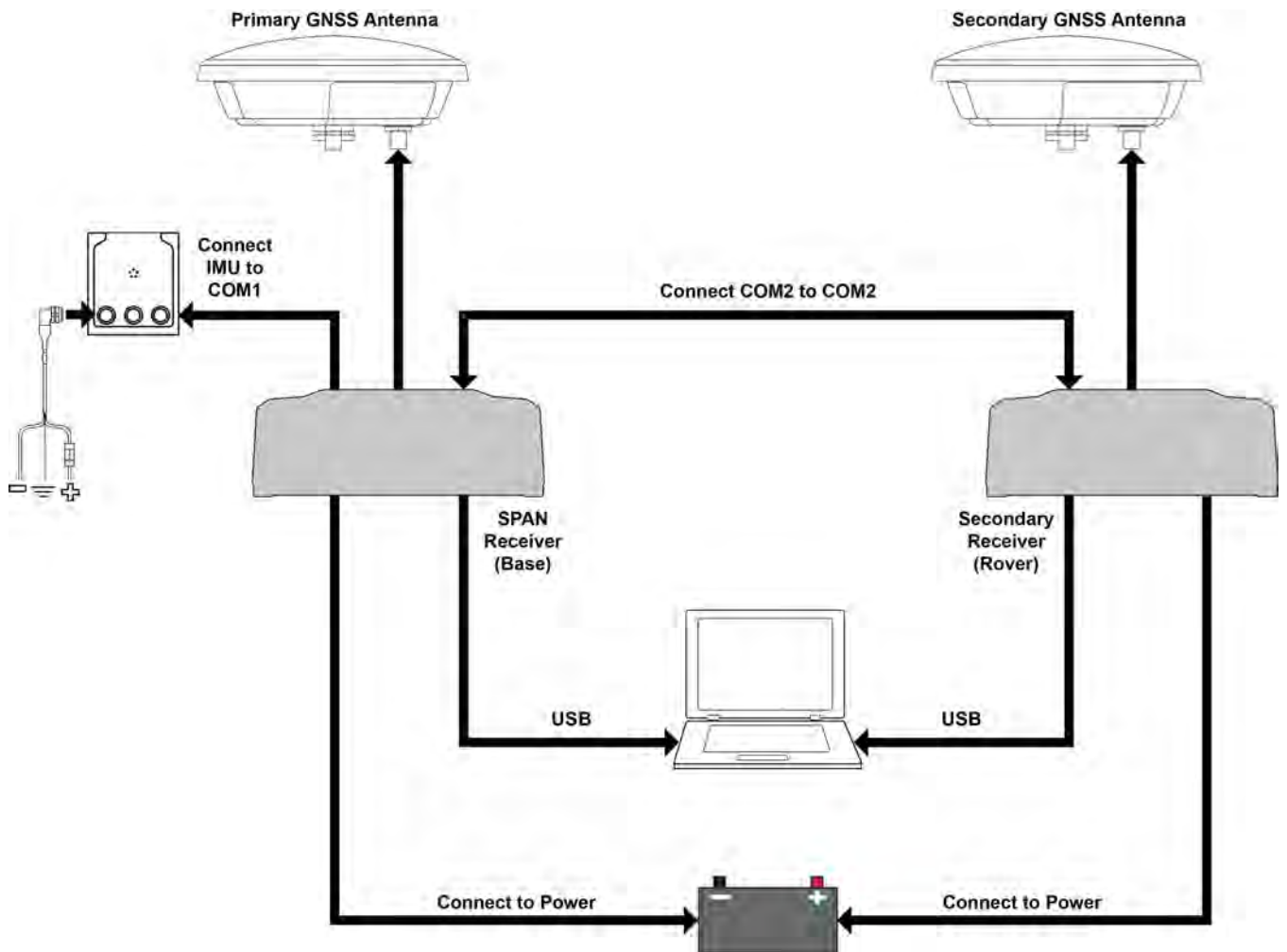
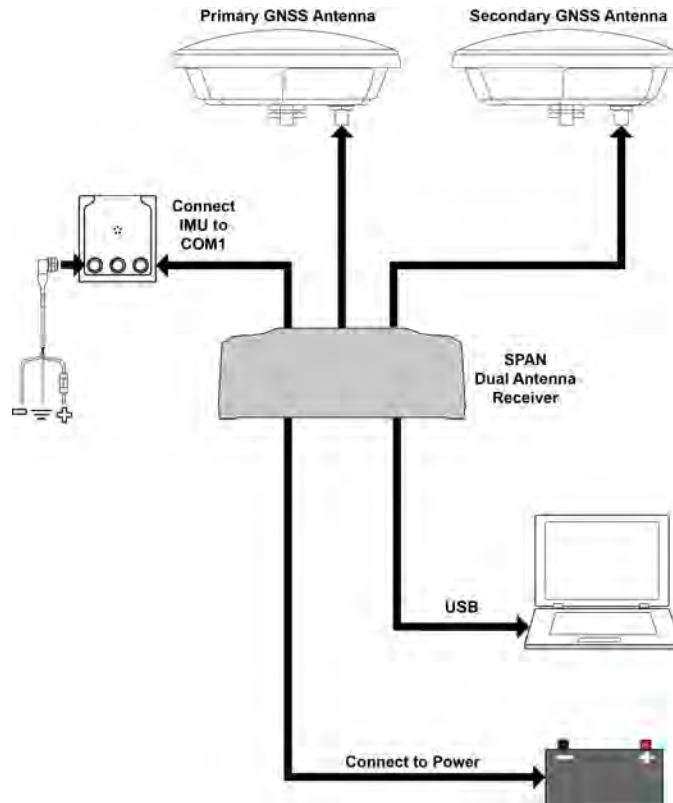

Figure 37: SPAN – single receiver dual antenna installation



4.2 Configuring dual antenna ALIGN with SPAN

The Dual Antenna ALIGN updates are used to help constrain the azimuth drift of the INS solution whenever possible. This is of the greatest value with lower-quality IMUs and in environments with low dynamics where the attitude error is less observable. Slow moving marine, agriculture and train applications are good examples of the intended use. By providing an external heading source, the solution drift can be constrained in these environments.

As with all ALIGN-capable products, the ALIGN solution is available from the **GPHDT** log and **HEADING2** log. For INS heading (azimuth), use the **INSATT** log, the **INSPVA** log, or any other desired SPAN log containing azimuth.

To monitor the status of the ALIGN update being applied, observe bit 4 of the **INS Extended Solution Status** field of the extended INS logs (INSATTX, INSPOSX, INSPVAX and INSVELX).

Following the appropriate dual antenna configuration below, the SPAN system can be configured for different alignment routines depending on the motion conditions experienced during the alignment period. The different alignment routines are described in *System start-up and alignment techniques* on page 101.

4.2.1 Setup and configuration

Dual Antenna ALIGN with SPAN can be configured on a dual-antenna receiver, e.g. OEM7720, or using two receivers. All dual-antenna receivers come with an ALIGN capable model. If using two receivers, the secondary non-SPAN receiver must be an ALIGN capable model. For additional information on models see the *Model List for NovAtel* (novatel.com/products/model-list-and-discontinued-products).

If using two receivers, both receivers should both be powered on, and a connection established between the SPAN receiver and the secondary non-SPAN receiver as shown in the example in *Figure 36: SPAN – two receiver dual antenna installation* on the previous page.

To enable the dual-antenna ALIGN solution to aid the INS alignment and provide heading updates, the offset between the antennas and the IMU must be known. This is achieved by entering lever arms to both antennas, using the **SETINSTRANSLATION** command.

To configure SPAN with ALIGN Aiding:

1. Enter the lever arm from the IMU to the primary antenna.

Abbreviated ASCII example:

```
SETINSTRANSLATION ANT1 0.54 0.32 1.20 0.03 0.03 0.05
```

2. Enter the lever arm from the IMU to the secondary antenna.

Abbreviated ASCII example:

```
SETINSTRANSLATION ANT2 0.54 2.32 1.20 0.03 0.03 0.05
```



Alternately, the angular offset between the dual-antenna baseline (from primary GNSS antenna to secondary GNSS antenna) and the IMU frame forward axis can be entered directly via the ALIGN parameter of the **SETINSROTATION** command.

It is recommended to enter the lever arms rather than entering the angular offset as the lever arms are easier to measure and will lead to better overall accuracy.

3. Use the **INSALIGNCONFIG** command to configure the connection ports, baud, and heading rate.



This command is not required for a dual-antenna receiver configuration, e.g. OEM7720, but can be used to adjust the heading rate – the port configuration fields will be ignored.

Abbreviated ASCII example:

```
INSALIGNCONFIG COM1 COM2 230400 5
```

For optimal performance of Dual Antenna with SPAN, an accurate ALIGN angular offset is required for each unique installation. This value can be calibrated should the entered ALIGN rotation value or value derived from the input lever arms be less accurate than 5 degrees. Refer to INSCALIBRATE command for details.

Refer to the [OEM7 Commands and Logs Reference Manual](#) for the syntax of the above commands.

4.2.2 Optional HEADINGOFFSET configuration

Optionally, the **HEADINGOFFSET** command can be used to rotate the ALIGN solution available in the **GPHDT** log and **HEADING2** log. This is occasionally desired when the baseline does not line up with the direction of travel but is not required for use with SPAN. If this additional offset in the **GPHDT** log and **HEADING2** log is desired, the following configuration details should be evaluated.

Most configurations of the HEADINGOFFSET command are not compatible with Waypoint Inertial Explorer and as such is not recommended for use if the data will be post processed. Contact support (see *Customer Support* on page 22) for more information.



The **HEADINGOFFSET** command will apply a rotational offset to the fields in the **HEADING2** log. This is handled differently depending on single receiver or dual receivers **ALIGN** setup, see below.

HEADINGOFFSET details when a dual-antenna receiver is used:

- The **HEADINGOFFSET** command will apply a rotational offset to the fields in **HEADING2** log. SPAN will automatically account for this additional rotation when applying the **ALIGN** update. As such, the provided **ANT2** translation or **ALIGN** rotation should match the physical installation as per the standard instructions.

HEADINGOFFSET details when two receivers are used:

- Option 1:
Issue the **HEADINGOFFSET** command on both the primary and secondary receivers. The secondary receiver will apply the rotational offset to the fields in the **HEADING2** logs being sent to the primary receiver. The primary receiver (running SPAN) will automatically account for this additional rotation when applying the **ALIGN** heading update. As such, the provided **ANT2** translation or **ALIGN** rotation should match the physical installation as per the standard instructions above.
- Option 2:
Issue the **HEADINGOFFSET** command on the secondary card where the **HEADING2** log is computed. This will apply a rotational offset to the fields in the **HEADING2** logs being sent to the primary card. The primary card (running SPAN) must be configured according to the offset orientation. This means that either the **ANT2** lever arm or the **ALIGN** rotation must be adjusted and entered such that they account for the offset heading orientation.

Appendix A IMU technical specifications

The following appendices detail the technical specifications of the SPAN compatible IMUs.

- *HG1700 IMU (single-connector enclosure)* on the next page
- *LN-200 IMU (single-connector enclosure)* on page 150
- *Universal IMU Enclosure (HG1700, LN200)* on page 154
- *IMU-CPT* on page 164
- *IMU-FSAS* on page 171
- *IMU-HG1900* on page 178
- *IMU-IGM-A1 and IMU-IGM-S1* on page 183
- *IMU-ISA-100C* on page 192
- *IMU-KVH1750* on page 204
- *IMU-P1750* on page 214
- *IMU-LN200* on page 222
- *IMU- μ IMU-IC* on page 227
- *OEM-IMU-ADIS-16488* on page 232
- *OEM-IMU-EG320N* on page 239
- *OEM-IMU-EG370N* on page 245
- *OEM-IMU-HG4930* on page 250
- *OEM-IMU-ISA-100C* on page 254
- *OEM-IMU-STIM300* on page 262
- *OEM-IMU- μ IMU-IC / OEM-IMU- μ IMU-IC-UART* on page 269
- *MIC – MEMS Interface Card* on page 277
- *UIC – Universal IMU Controller* on page 290

For technical specifications for the SPAN compatible receivers and GNSS+INS combined enclosures, see the [OEM7 Installation and Operation User Manual](#), [PwrPak7 Installation and Operation User Manual](#) or [CPT7 Installation and Operation User Manual](#).

A.1 HG1700 IMU (single-connector enclosure)

Table 36: HG1700 IMU physical specifications

Physical	
IMU enclosure size	193 mm x 167 mm x 100 mm (7.6" x 6.6" x 3.9")
IMU size	160 mm x 160 mm x 100 mm (6.3" x 6.3" x 3.9")
IMU + enclosure weight	3.4 kg (7.49 lb.)

See the following sections for more information about the HG1700 IMU.

- *HG1700 IMU mechanical drawings* on the next page
- *HG1700 IMU performance* on page 148
- *HG1700 electrical and environmental* on page 149
- *Interface cable for the HG1700 IMU* on page 149

A.1.1 HG1700 IMU mechanical drawings



In the following diagrams, the dimensions are in millimetres.

Figure 38: HG1700 top/bottom dimensions

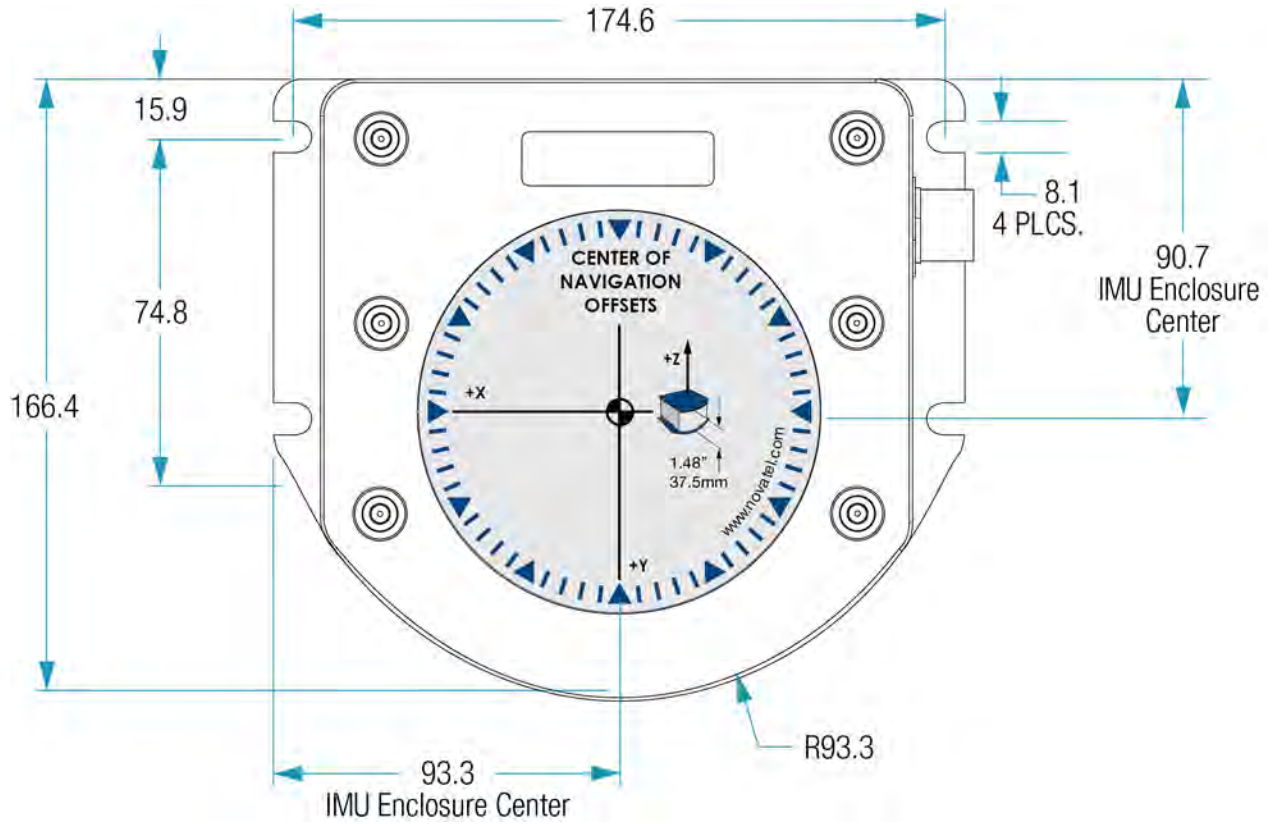
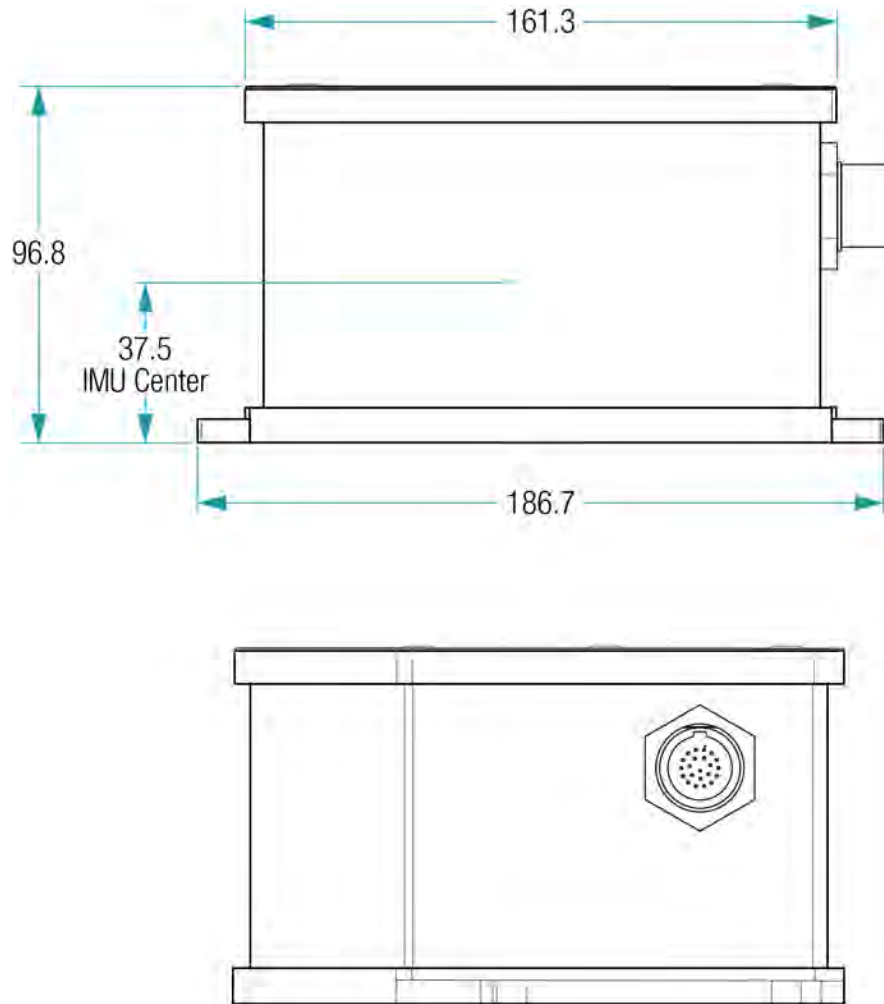

Figure 39: HG1700 enclosure side dimensions



The centre of navigation, shown on the HG1700 label, for the internal IMU is the same as the enclosure centre. The enclosure centre measurements are labelled as IMU Enclosure Centre in these figures.

A.1.2 HG1700 IMU performance

Table 37: HG1700-AG58 IMU performance

Gyroscope performance	
Technology	Ring laser
Dynamic range	1074 °/s
Bias drift	1.0 °/hr
Angular random walk	0.125 °/√hr
Accelerometer performance	
Technology	RBA
Dynamic range	37 g
Bias drift	1.0 mg
Velocity random walk	0.02 m/s/√hr
Data rate	
IMU measurement	100 Hz

Table 38: HG1700-AG62 IMU performance

Gyroscope performance	
Technology	Ring laser
Dynamic range	1000 °/s
Gyro rate bias	5.0 °/hr
Gyro rate scale factor	150 ppm
Angular random walk	0.5 °/√hr
Accelerometer performance	
Technology	RBA
Dynamic range	50 g
Accelerometer linearity	500 ppm
Accelerometer scale factor	300 ppm
Accelerometer bias	2.0 mg
Data rate	
IMU measurement	100 Hz

A.1.3 HG1700 electrical and environmental

Table 39: HG1700 electrical specifications

Electrical	
IMU power consumption	IMU-H58: 9 W (max) IMU-H62: 8 W (max)
IMU input voltage	+12 to +28 VDC
Recommended fuse	1.0 A slow blow
Input/Output connectors	MIL-C-38999-III, 22 pin (all IMUs)
IMU interface	RS-232 or RS-422

Table 40: HG1700 environmental specifications

Environmental (IMU)	
Operating temperature	-30°C to +60°C (-22°F to 140°F)
Storage temperature	-45°C to +80°C (-49°F to 176°F)
Humidity	95% non-condensing

A.1.4 Interface cable for the HG1700 IMU

The IMU interface cable provides power to the IMU from an external power source and enables communication between the receiver and IMU. The HG1700 IMU uses the Universal IMU Enclosure Interface cable (see *Universal IMU Enclosure interface cable* on page 162).

A.2 LN-200 IMU (single-connector enclosure)

Table 41: LN-200 IMU physical specifications

Physical	
IMU enclosure size	135 mm x 153 mm x 130 mm (5.315" x 6.024" x 5.118")
IMU size	89 mm D x 85 mm H (3.504" D x 3.346" H)
IMU weight	3.19 kg (7.02 lb.)

See the following sections for more information about the LN-200 IMU.

- *LN-200 IMU mechanical drawings* on the next page
- *LN-200 IMU performance* on page 153
- *LN-200 electrical and environmental* on page 153
- *Interface cable for the LN-200 IMU* on page 153

Figure 41: LN-200 Enclosure side dimensions

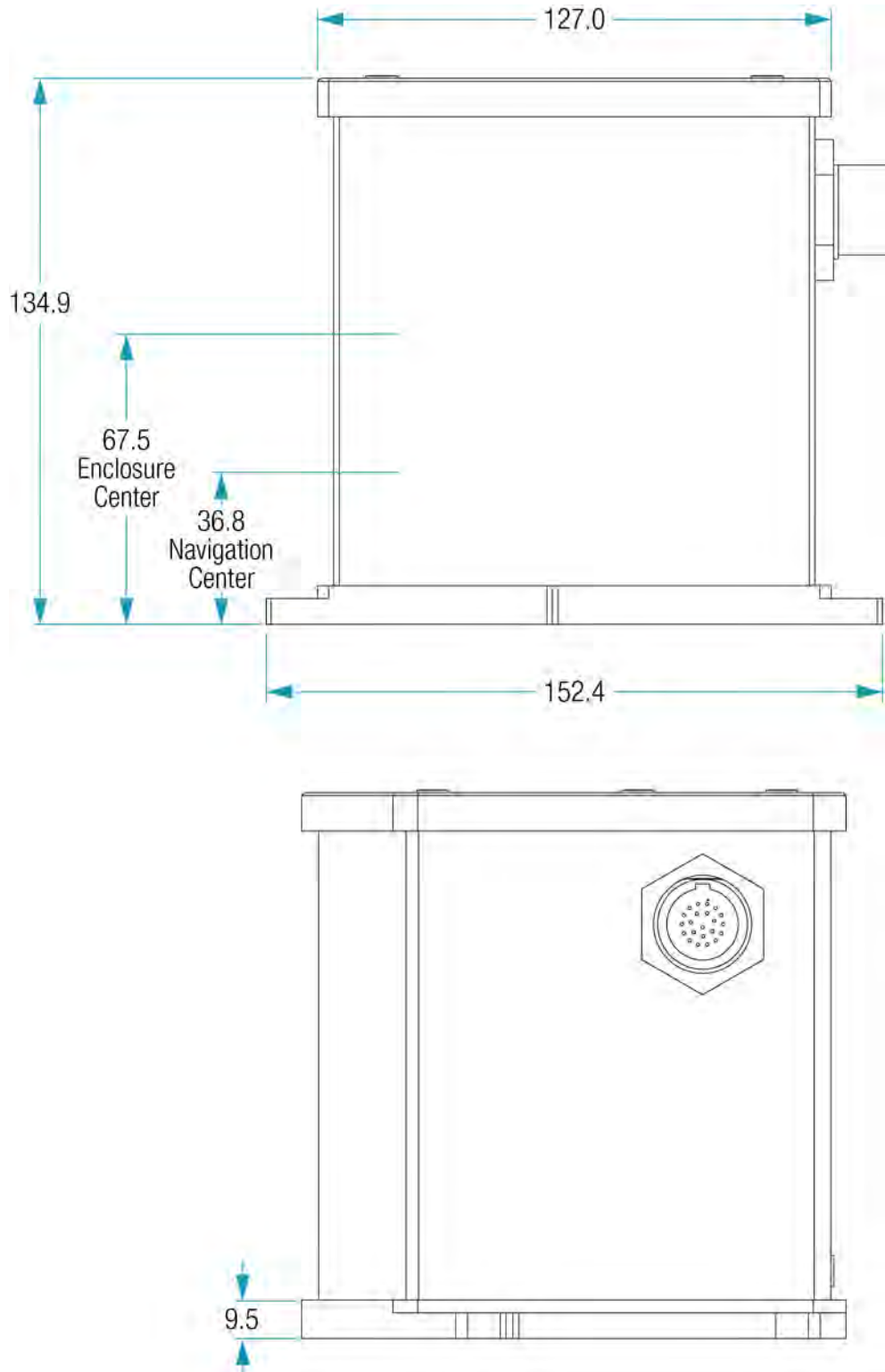

The Centre of Navigation offsets, shown on the LN-200 label, are for the internal IMU and are different than for the enclosure centre. The enclosure centre is labelled as IMU Centre in these figures.

A.2.2 LN-200 IMU performance

Table 42: LN-200 IMU performance

Gyroscope performance	
Technology	FOG
Dynamic range	1420 °/s
Bias repeatability	1.0 °/hr
Angular random walk	0.07 °/√hr
Accelerometer performance	
Technology	MEMS
Dynamic range	40 g
Bias repeatability	0.3 mg
Data rate	
IMU measurement	200 Hz

A.2.3 LN-200 electrical and environmental

Table 43: LN-200 electrical specifications

Electrical	
IMU power consumption	16 W (max)
IMU input voltage	+12 to +28 VDC
Recommended fuse	1.6 A slow blow
Input/Output connectors	MIL-C-38999-III, 22 pin (all IMUs)
IMU interface	RS-232 or RS-422

Table 44: LN-200 environmental specifications

Environmental (LN-200 IMU)	
Operating temperature	-30°C to +60°C (-22°F to 140°F)
Storage temperature	-45°C to +80°C (-49°F to 176°F)
Humidity	95% non-condensing

A.2.4 Interface cable for the LN-200 IMU

The IMU interface cable provides power to the IMU from an external power source and enables communication between the receiver and IMU. The LN-200 IMU uses the Universal IMU Enclosure Interface cable (see *Universal IMU Enclosure interface cable* on page 162).

A.3 Universal IMU Enclosure (HG1700, LN200)

The Universal IMU Enclosure is available with the HG1700 and LN-200 IMUs.

Table 45: Universal IMU Enclosure physical specifications

PHYSICAL	
IMU enclosure size	168 mm x 195 mm x 146 mm
IMU enclosure weight	4.25 kg

See the following sections for more information about the IMUs available in the Universal IMU Enclosure.

- *Universal IMU Enclosure mechanical drawings* on the next page
- *IMU performance* on page 159
- *Electrical and environmental* on page 161
- *Universal IMU Enclosure interface cable* on page 162

A.3.1 Universal IMU Enclosure mechanical drawings



In the following diagrams, the dimensions are in millimetres [inches].

Figure 42: Universal IMU Enclosure side dimensions

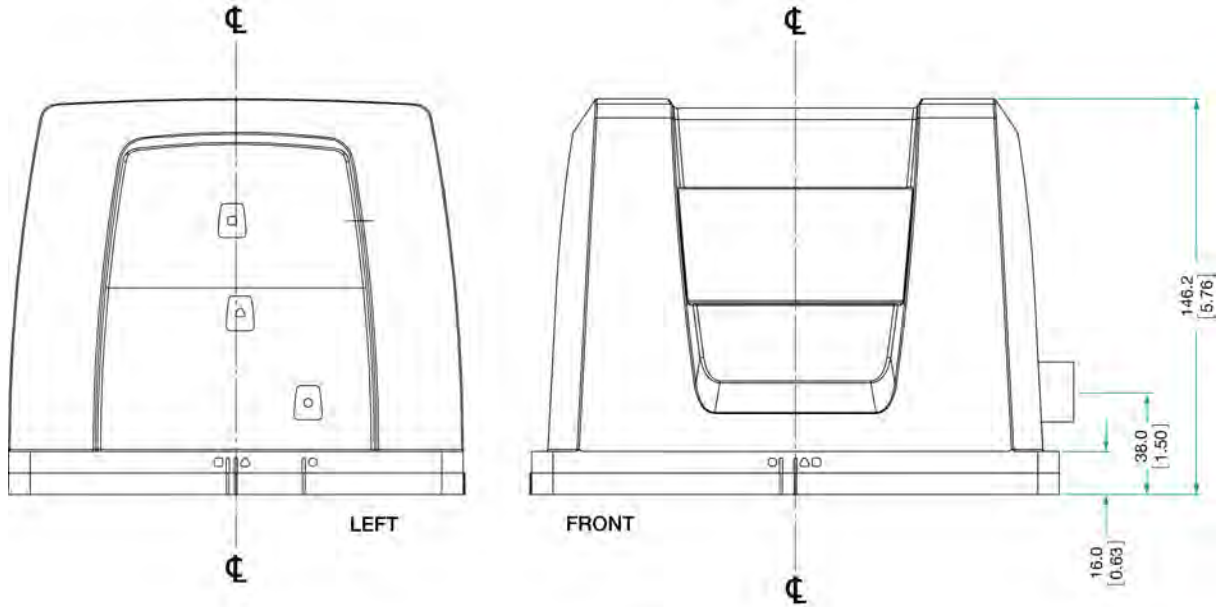

Figure 43: Universal IMU Enclosure top/bottom dimensions

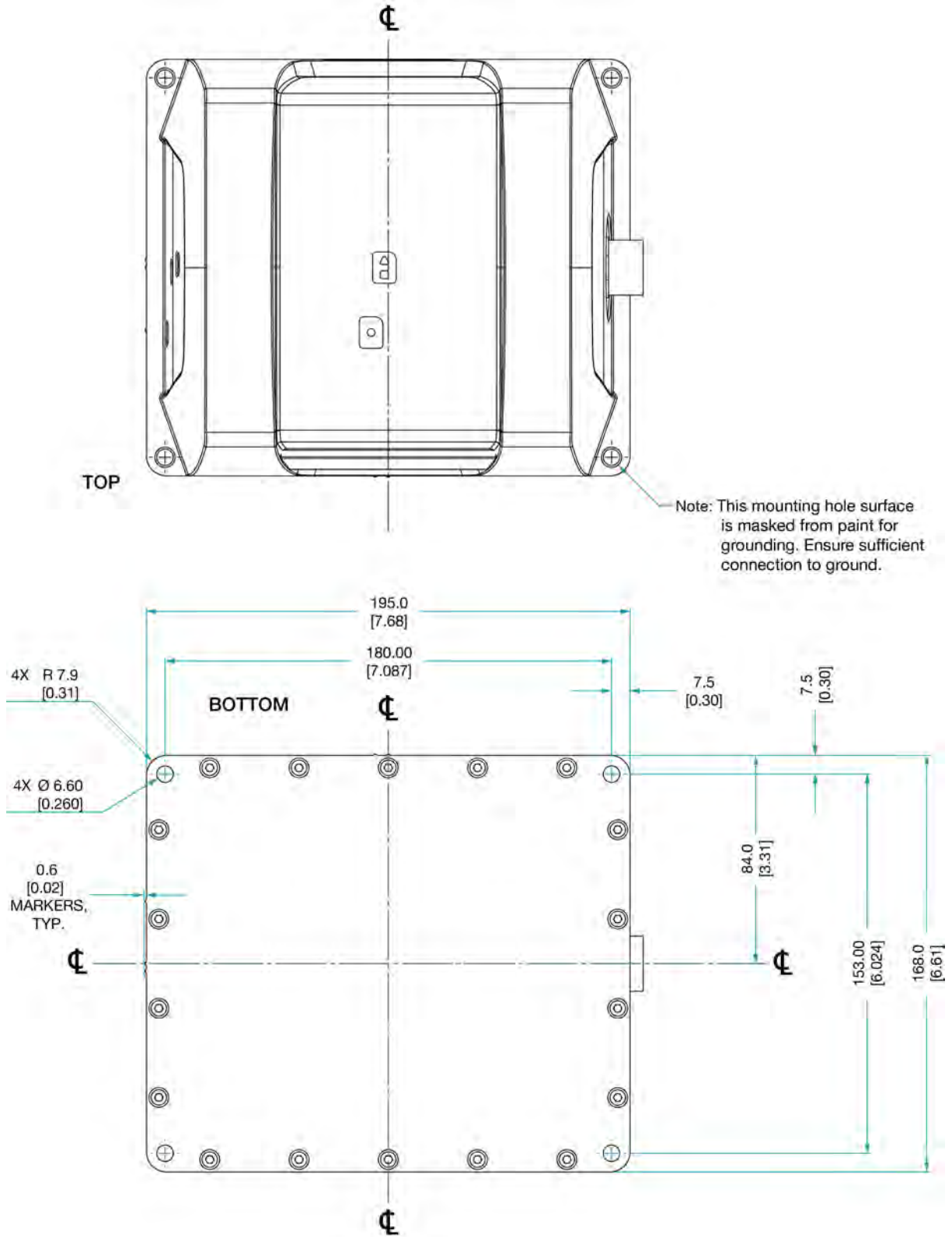

Figure 44: Universal IMU Enclosure centre of navigation

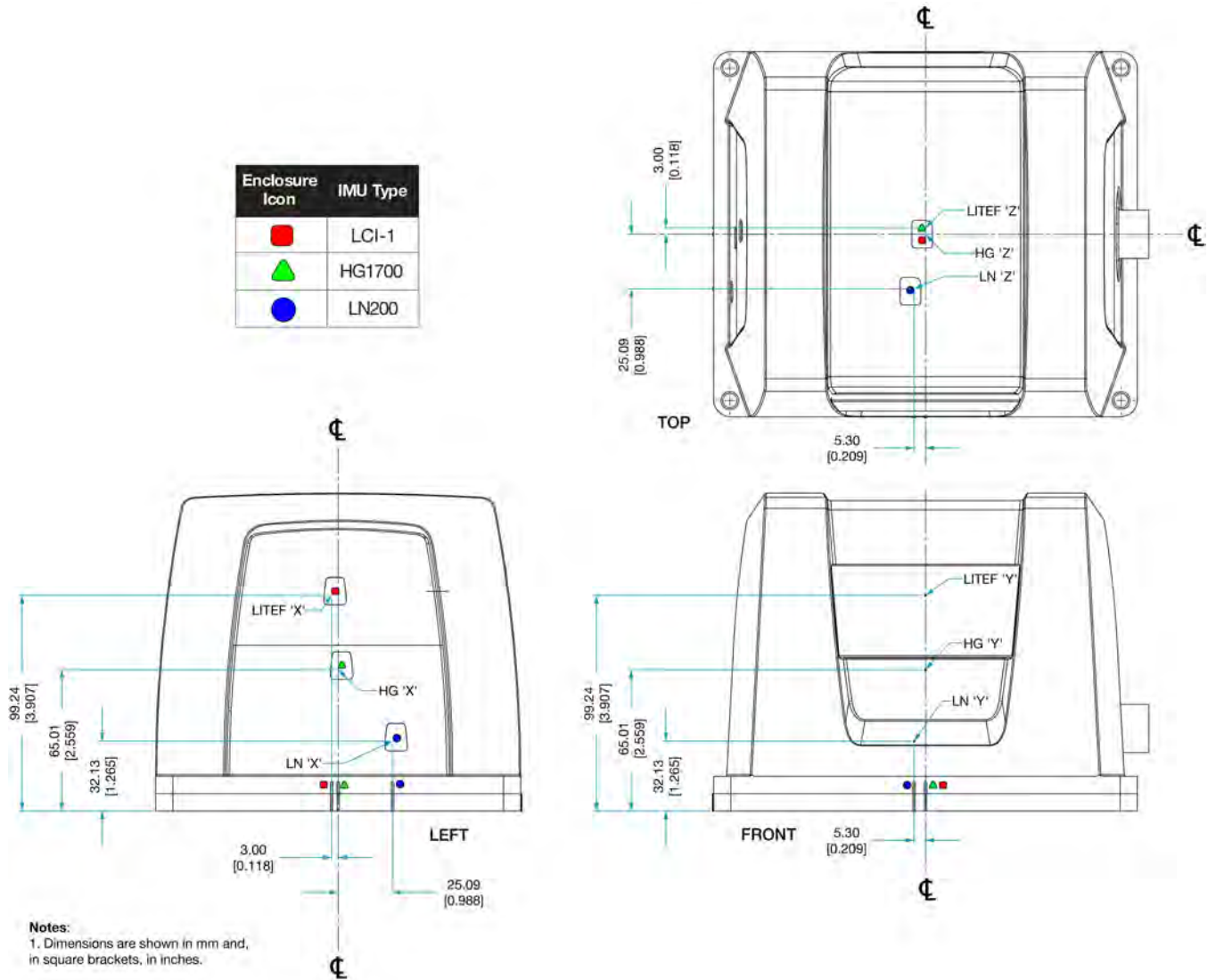
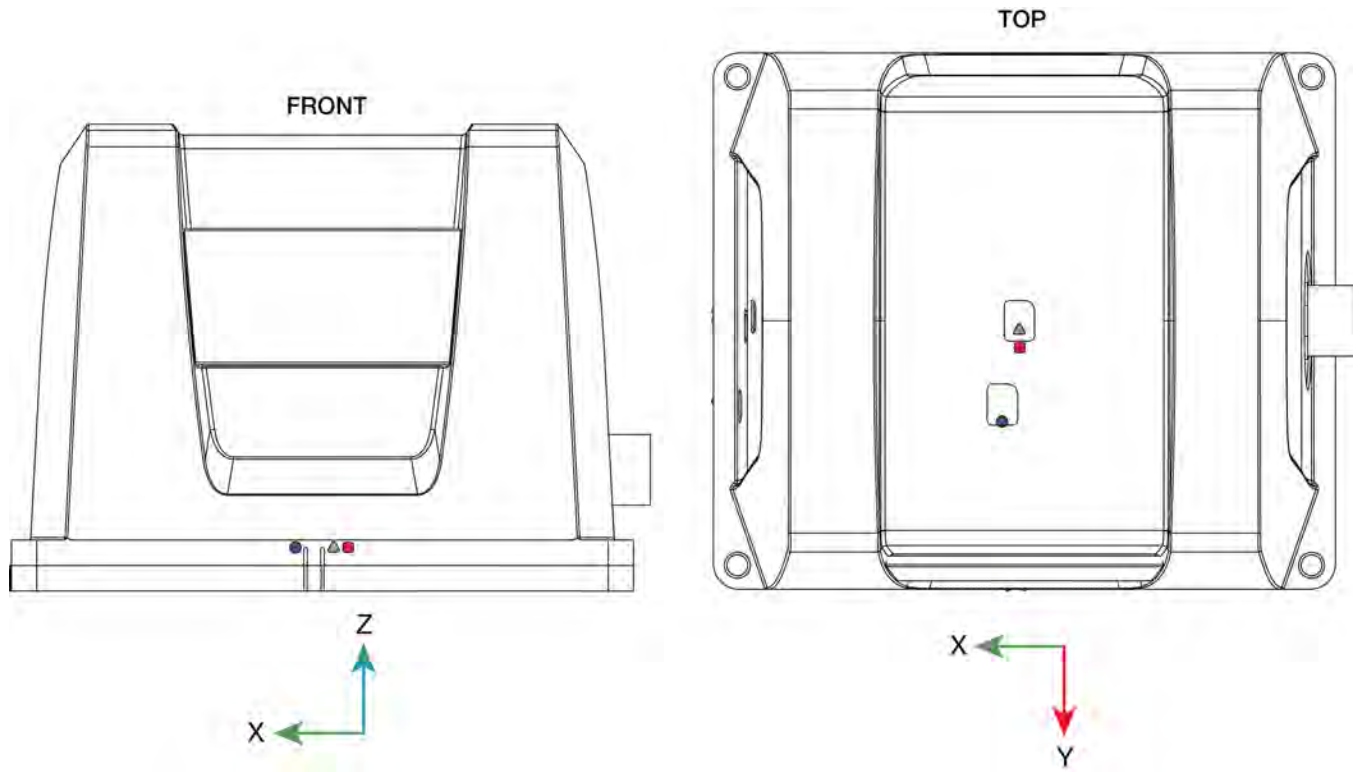

Figure 45: Universal IMU Enclosure frame axis



A.3.2 IMU performance

Table 46: HG1700-AG58 IMU performance

Gyroscope performance	
Technology	Ring laser
Dynamic range	1074 °/s
Bias drift	1.0 °/hr
Angular random walk	0.125 °/√hr
Accelerometer performance	
Technology	RBA
Dynamic range	37 g
Bias drift	1.0 mg
Velocity random walk	0.02 m/s/√hr
Data rate	
IMU measurement	100 Hz

Table 47: HG1700-AG62 IMU performance

Gyroscope performance	
Technology	Ring laser
Dynamic range	1000 °/s
Gyro rate bias	5.0 °/hr
Gyro rate scale factor	150 ppm
Angular random walk	0.5 °/√hr
Accelerometer performance	
Technology	RBA
Dynamic range	50 g
Accelerometer linearity	500 ppm
Accelerometer scale factor	300 ppm
Accelerometer bias	2.0 mg
Data rate	
IMU measurement	100 Hz

Table 48: LN-200 IMU performance

Gyroscope performance	
Technology	FOG
Dynamic range	1420 °/s
Bias repeatability	1.0 °/hr
Angular random walk	0.07 °/√hr
Accelerometer performance	
Technology	MEMS
Dynamic range	40 g
Bias repeatability	0.3 mg
Data rate	
IMU measurement	200 Hz

A.3.3 Electrical and environmental

Table 49: Universal IMU Enclosure electrical specifications

Electrical	
IMU power consumption	HG1700-AG58: 9 W (max) HG1700-AG62: 8 W (max) LN-200: 16 W (typical)
IMU input voltage	+12 to +28 VDC (all IMUs)
Recommended fuse	1.8 A slow blow (all IMUs)
Input/Output connectors	MIL-C-38999-III, 22 pin (all IMUs)
IMU interface	RS-232 or RS-422

Table 50: Universal IMU Enclosure environmental specifications

Environmental	
Temperature	HG1700-AG58, HG1700-AG62 Operating: -30°C to +60°C Storage: -45°C to +80°C
	LN-200 Operating: -30°C to +60°C Storage: -45°C to +80°C
Humidity	Operates at 95% RH, non-condensing (all IMUs)

A.3.4 Universal IMU Enclosure interface cable

The NovAtel part number for the Universal IMU Enclosure interface cable is 01018977 (see *Figure 46: Universal IMU Enclosure interface cable* below). This cable provides power to the IMU from an external power source and enables communication between the receiver and the IMU.

Figure 46: Universal IMU Enclosure interface cable

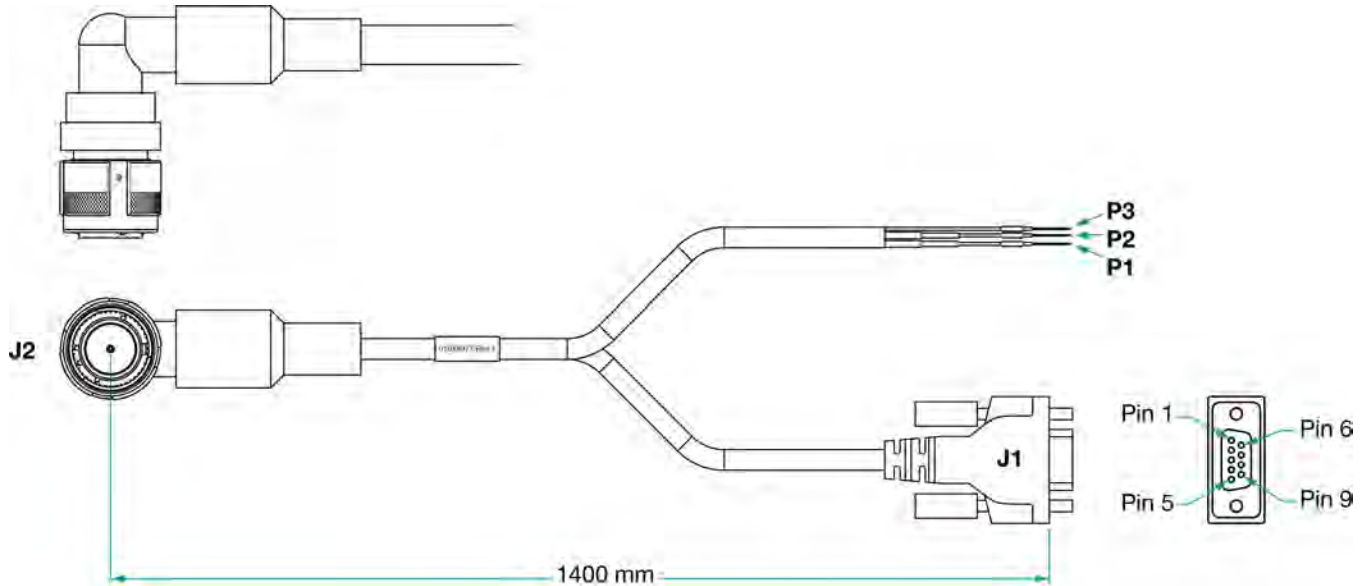

Table 51: Universal IMU Enclosure Interface cable pinout

J2 pin	Function	Connector	Pin/Label
1	$V_{IN} (-)$	P2	Vin (-)
22	$V_{IN} (-)$		
2	Not used		
3	$V_{IN} (+)$	P1	Vin (+)
21	$V_{IN} (+)$		
4	Not used		
5	Not used		
6	Not used		
7	DAS (+)	J1	1
8	Not used		
9	DAS GND (-)	J1	5
10	Not used		
11	OEM_CTS/Rx-	J1	8

J2 pin	Function	Connector	Pin/Label
12	OEM_Rx/Rx+	J1	2
13	Not used		
14	DGND	J1	5
15	DGND	J1	5
16	Not used		
17	Not used		
18	Not used		
19	OEM_Tx/Tx+	J1	3
20	OEM_RTS/Tx-	J1	7
	Shield	P3	Shield



Pins 4, 6 and 9 of the J1 connector are not used.

Custom cable recommendations

The tables below provide recommendations for creating custom cables to replace the Universal IMU Enclosure interface cable (01018977).

Table 52: Connectors

Connector	Description
J1	DB-9, female
J2	MIL-DTL-38999 III, plug

Table 53: Maximum cable length

IMU	RS-232	RS-422
HG1700, LN-200, LCI-1	< 2.0 metres	< 50 metres
IMU-FSAS	N/A	< 1.5 metres

A.4 IMU-CPT

Table 54: IMU-CPT physical specifications

Physical	
IMU size	168 mm W X 152 mm L X 89 mm H
IMU weight	2.29 kg

See the following sections for more information about the IMU-CPT.

- *IMU-CPT mechanical drawings* on the next page
- *IMU-CPT sensor specifications* on page 167
- *IMU-CPT electrical and environmental* on page 168
- *IMU-CPT cable* on page 169

A.4.1 IMU-CPT mechanical drawings



In the following diagrams, the dimensions in inches and [millimetres].

Figure 47: IMU-CPT side and perspective view

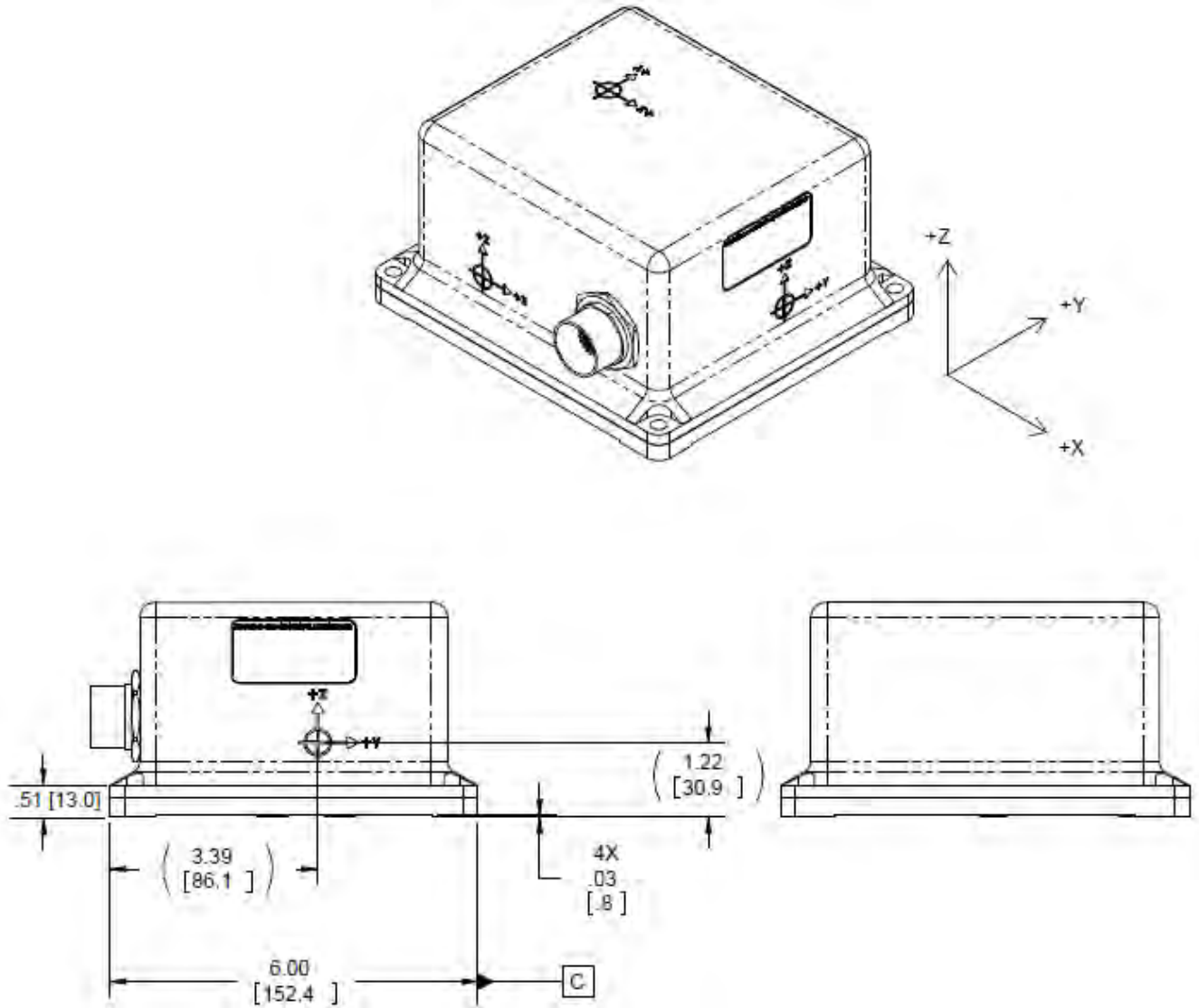
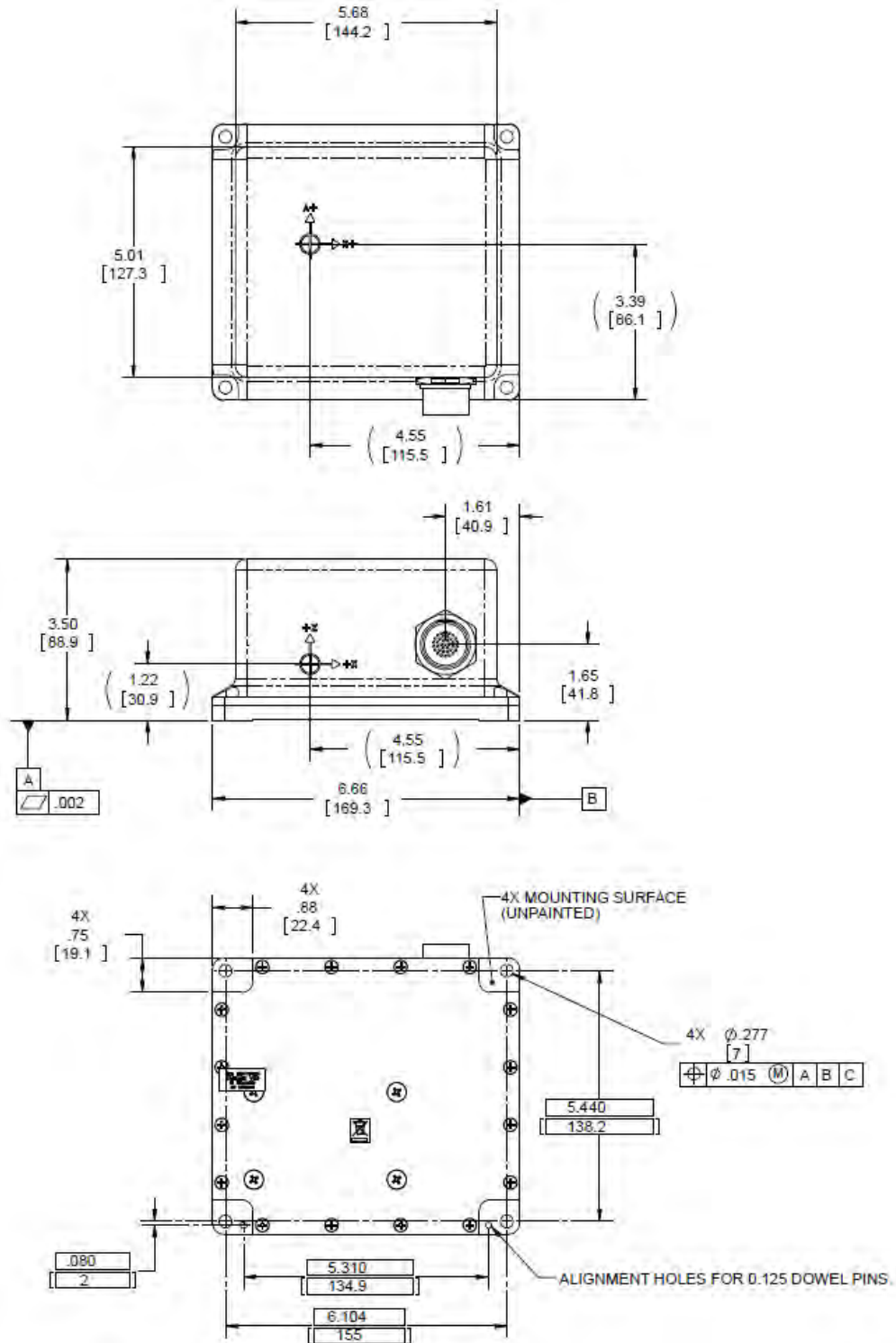

Figure 48: IMU-CPT top, front and bottom view



A.4.2 IMU-CPT sensor specifications

Table 55: IMU-CPT performance

Gyroscope performance	
Bias offset	± 20 °/hr
Turn on to turn on bias repeatability (compensated)	± 3 °/hr
In run bias variation, at constant temperature	1 °/hr @ 1σ
Scale factor error (total)	1500 ppm, 1σ
Scale factor linearity	1000 ppm, 1σ
Temperature dependent SF variation	500 ppm, 1σ
Angular random walk	0.0667 °/ $\sqrt{\text{hr}}$ @ 1σ
Maximum input	± 375 °/s
Accelerometer performance	
Bias offset	± 50 mg
Turn on to turn on bias repeatability	± 0.75 mg
In run bias variation, at constant temperature	0.25 mg @ 1σ
Temperature dependent bias variation	0.5 mg/°C @ 1σ
Scale factor error (total)	4000 ppm, 1σ
Temperature dependent SF variation	1000 ppm, 1σ
Accelerometer noise	55 $\mu\text{g}/\sqrt{\text{Hz}}$ @ 1σ
Bandwidth	50 Hz
Accelerometer bias	± 10 g
Data rate	
IMU measurement	100 Hz

A.4.3 IMU-CPT electrical and environmental

Table 56: IMU-CPT electrical specifications

Electrical	
Input power	9 - 18 VDC
Power consumption	13 W (max)
Recommended fuse	2.0 A slow blow
Power and I/O connector	MIL-DTL-38999 Series 3
Start-up time (valid data)	< 5 seconds

Table 57: IMU-CPT environmental specifications

Environmental	
Temperature, operational	-40°C to +65°C
Temperature, non-operational	-50°C to +80°C
Vibration, operational	6 g rms, 20 Hz -2 KHz
Vibration, non-operational	8 g rms, 20 Hz -2 KHz
Shock, operational	7g 6-10 msec, 1/2 sine
Shock, non-operational	60 g 6-10 msec, 1/2 sine
Altitude	-1000 to 50,000 ft.
Humidity	95% at 35°C, 48 hrs
MTBF	≥ 10,500 hours

A.4.4 IMU-CPT cable

The NovAtel part number for the IMU-CPT cable is 01018966. This cable provides power to the IMU from an external power source and enables communication between the receiver and the IMU.

Figure 49: IMU-CPT development terminated cable

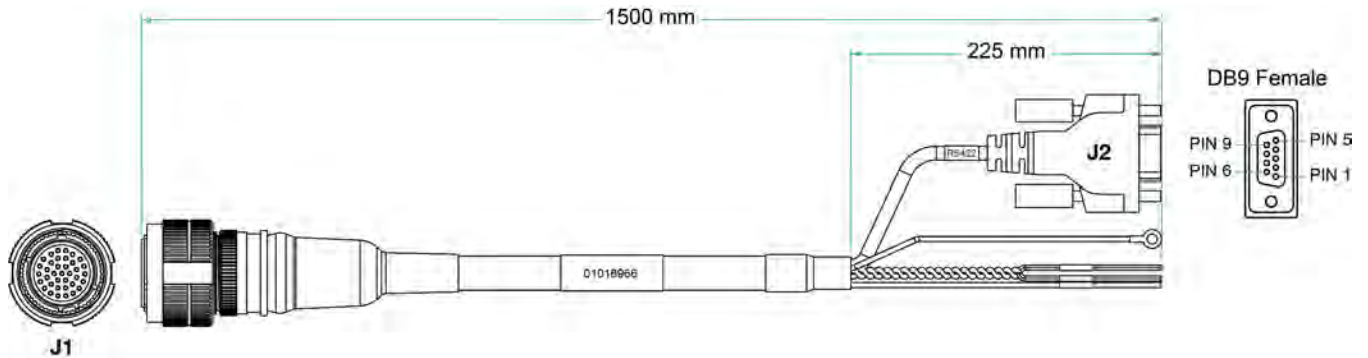

Table 58: IMU-CPT connector pinout descriptions

J1 pins	Function	J2 (female DB9) pins	Bare connectors
1	Power Return		Labelled Pin 1
2	9-16 VDC Power Input		Labelled Pin 2
3-20	Reserved		
21	IMU RS422 TX+	2	
22	IMU RS422 TX-	8	
23-24	Reserved		
25	IMU RS422 Signal Ground	5	
26-34	Reserved		
35	TOV Out	9	
36	External Clock Input	1	
37	Chassis GND		Labelled Pin 37
	Chassis GND		Ring lug

Custom cable recommendations

The tables below provide recommendations for creating custom cables to replace the IMU-CPT cable (01018966).

Table 59: Connectors

Connector	Description
J1	MIL-DTL 38999, 37 connector, plug
J2	DB-9, female

Table 60: Maximum cable length

IMU	RS-422
IMU-CPT	< 1.5 metres

A.5 IMU-FSAS

Table 61: IMU-FSAS physical specifications

Physical	
IMU size	128 mm x 128 mm x 98 mm (5.04" x 5.04" x 3.86")
IMU weight	2.1 kg (4.63 lb.)

See the following sections for more information about the IMU-FSAS.

- *IMU-FSAS mechanical drawings* on the next page
- *IMU-FSAS performance* on page 174
- *IMU-FSAS electrical and environmental* on page 174
- *Interface cable for IMU-FSAS* on page 175
- *IMU-FSAS cable with wheel sensor* on page 175

A.5.1 IMU-FSAS mechanical drawings



In the following diagrams, the dimensions are in millimetres.

Figure 50: IMU-FSAS top dimensions

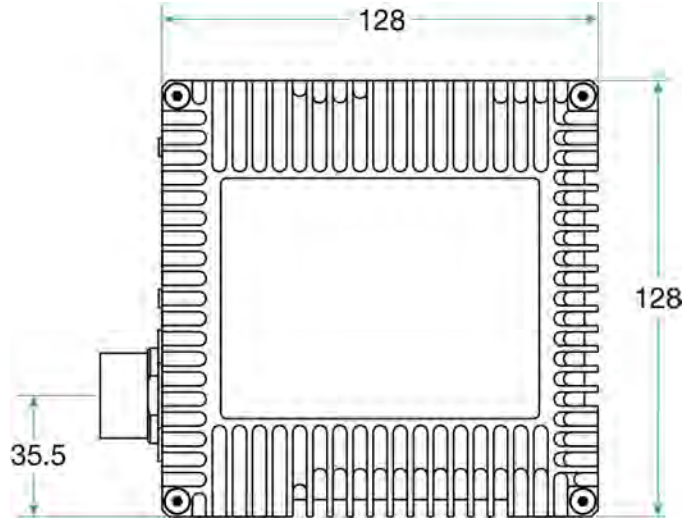

Figure 51: IMU-FSAS bottom dimensions

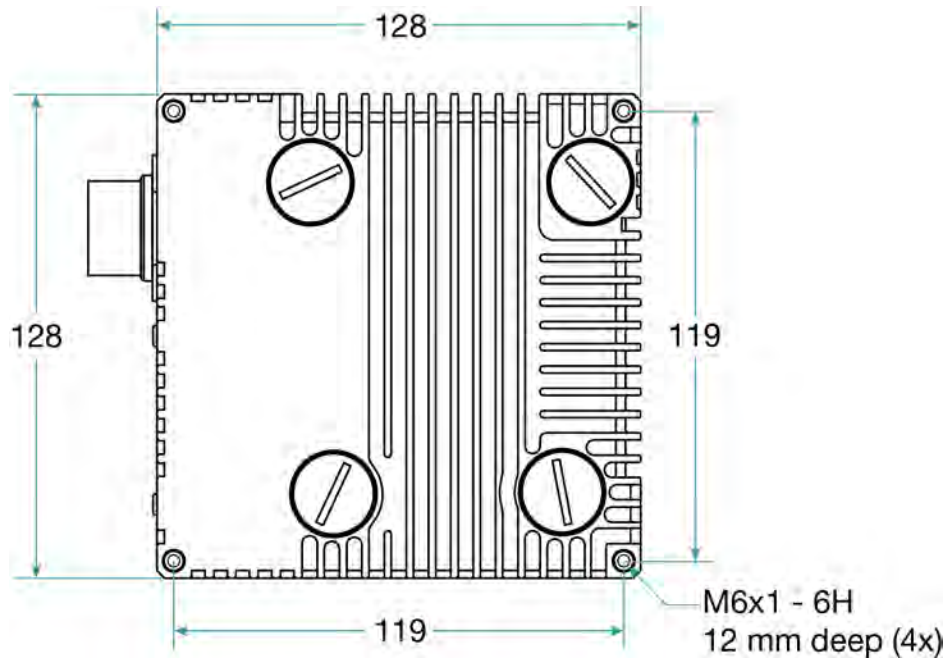

Figure 52: IMU-FSAS side dimensions

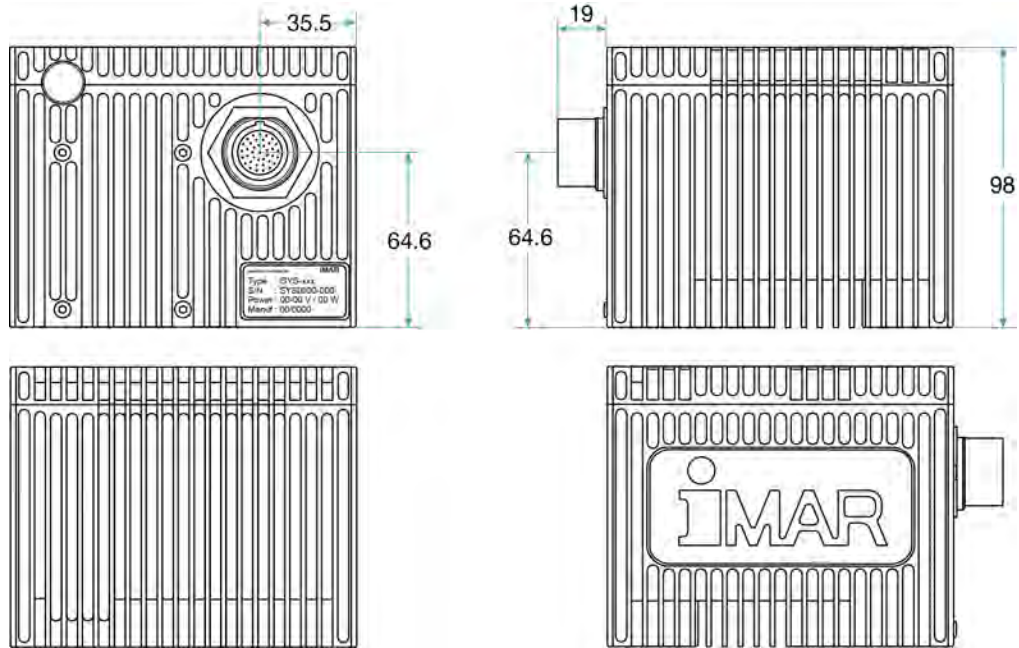
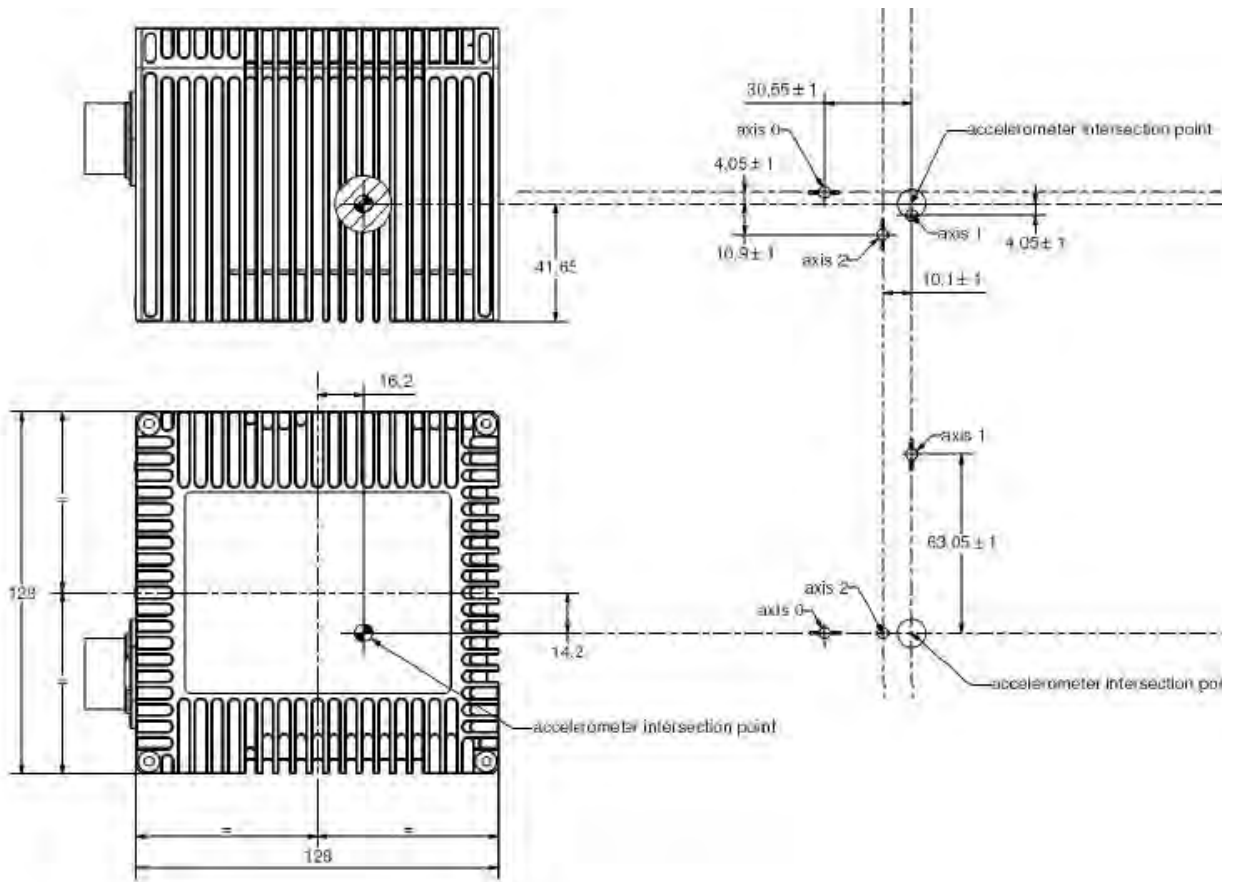

Figure 53: IMU-FSAS centre of navigation



A.5.2 IMU-FSAS performance

Table 62: IMU-FSAS performance

Gyroscope performance	
Gyro input range	±450 °/s
Gyro rate bias	<0.75°/hr
Gyro rate scale factor	300 ppm
Angular random walk	0.1 °/√hr
Accelerometer performance	
Accelerometer range	±5 g (±20 g optional)
Accelerometer scale factor	300 ppm
Accelerometer bias	1.0 mg
Data rate	
IMU measurement	200 Hz

A.5.3 IMU-FSAS electrical and environmental

Table 63: IMU-FSAS electrical specifications

Electrical	
IMU power consumption	16 W (max)
IMU input voltage	+10 to +34 VDC
Recommended fuse	2.0 A slow blow
System power consumption	13.8 W (typical)
Input/Output connector	MIL-C-38999-III
IMU interface	RS-422

Table 64: IMU-FSAS environmental specifications

Environmental	
Operating temperature	-40°C to +71°C (-40°F to 160°F)
Storage temperature	-40°C to +85°C (-40°F to 185°F)
Humidity	95% non-condensing

A.5.4 Interface cable for IMU-FSAS

The IMU interface cable can be one of the following cables:

Cable	NovAtel part number	Comment	For more information
Universal IMU Enclosure Interface cable	01018977	For standard pinout enclosures.	See <i>Universal IMU Enclosure interface cable</i> on page 162
IMU-FSAS cable with Wheel Sensor	01018388	For standard pinout enclosures. Includes an additional connector for wheel sensor cabling.	See <i>IMU-FSAS cable with wheel sensor</i> below

A.5.5 IMU-FSAS cable with wheel sensor

The NovAtel part number for the IMU-FSAS cable with Wheel Sensor is 01018388 (see *Figure 54: IMU-FSAS interface cable with wheel sensor* below). This cable:

- provides power to the IMU from an external power source
- enables input and output between the receiver and the IMU
- enables input from an optional Wheel Sensor

See also *DMI connected to an IMU* on page 122.

Figure 54: IMU-FSAS interface cable with wheel sensor

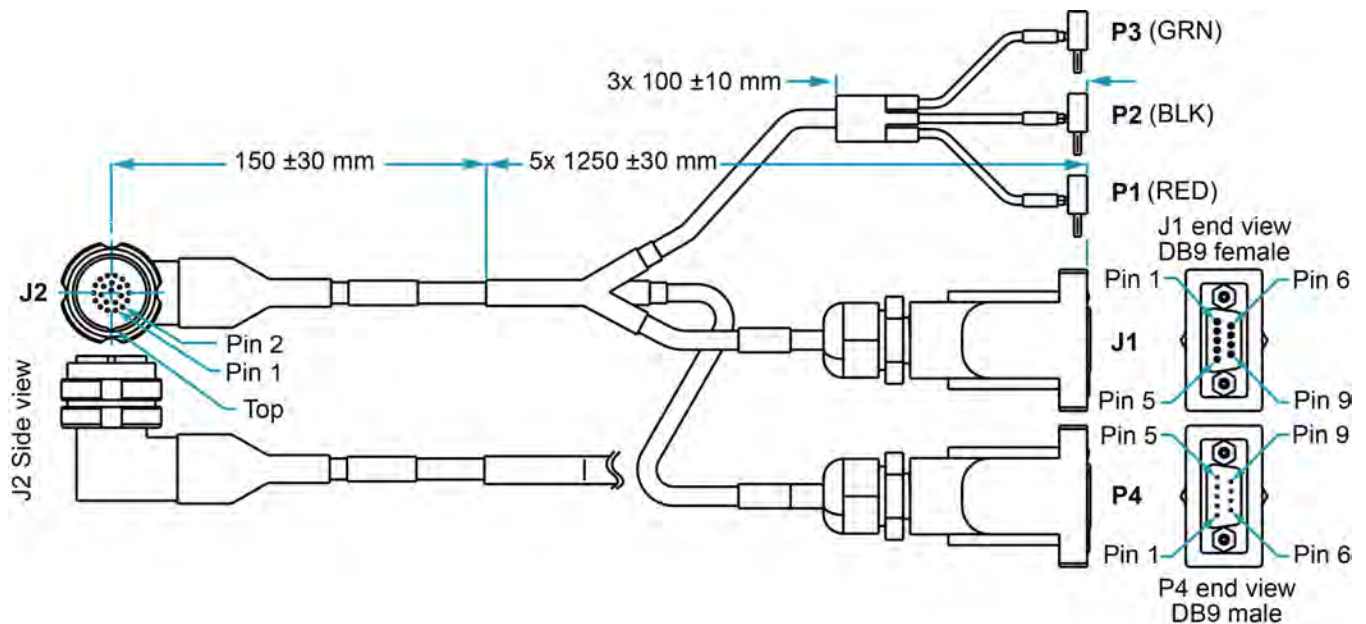

Table 65: IMU-FSAS cable with wheel sensor pinout

MIL-C-38999 III connector pin	Function	Power 4 mm plugs	J1 female DB9	P4 male DB9	Comments
1	Vin(-)	Colour: black Label: Vin (-)			Power ground
22	Vin(-)				
2	ODO_AN			7	Wheel sensor input A(-), opto-coupler: +2 to +6 V (RS-422 compatible)
4	ODO_A			6	Wheel sensor input A(+), opto-coupler: +2 to +6 V (RS-422 compatible)
3	Vin(+)	Colour: red Label: Vin(+)			+10 to +34 VDC
21	Vin(+)				
5	Not used				
6	Not used				
7	DAS(+)		1		Shielded data acquisition signal (LVCMOS to VARF)
9	DAS GN (-)		5		Shielded ground reference for data acquisition and control signals
8	Reserved				
10	Reserved				
11	OEM_CTS/ Rx-		8		Twisted pair; serial data output signal / RS-422(-)
12	OEM_Rx/ Rx+		2		Twisted pair; serial data output signal / RS-422(+)
13	Reserved				
14	DGND		5		Digital ground
15	DGND		5		Digital ground
16	ODO_B			3	Wheel sensor input B(+), opto-coupler: +2 to +6 V (RS-422 compatible)
17	ODO_BN			1	Wheel sensor input B(-), opto-coupler: +2 to +6 V (RS-422 compatible)
18	Reserved				

MIL-C-38999 III connector pin	Function	Power 4 mm plugs	J1 female DB9	P4 male DB9	Comments
19	OEM_Tx/ Tx+		3		Twisted pair; serial data in / RS-422(+)
20	OEM_ RTS/ Tx		7		Twisted pair; serial data in / RS-422(-)

Custom cable recommendations

The tables below provide recommendations for creating custom cables to replace the IMU-FSAS cable with Wheel Sensor (01018388).

Table 66: Connectors

Connector	Description
J1	DB-9, female
J2	MIL-DTL-38999 III, plug
P4	DB-9, male

Table 67: Maximum cable length

IMU	RS-422
IMU-FSAS	< 1.5 metres

A.6 IMU-HG1900

The IMU-HG1900 contains a Honeywell HG1900 IMU.

Table 68: IMU-HG1900 physical specifications

Physical	
IMU enclosure size	130 mm x 130 mm x 125 mm
IMU enclosure weight	2.5 kg

See the following sections for more information about the IMU-HG1900.

- *IMU-HG1900 mechanical drawings* on the next page
- *IMU-HG1900 sensor specifications* on page 181
- *IMU-HG1900 electrical and environmental* on page 182
- *IMU-HG1900 cables* on page 182

A.6.1 IMU-HG1900 mechanical drawings



In the following diagrams, the dimensions are in millimetres.

Figure 55: IMU-HG1900 dimensions

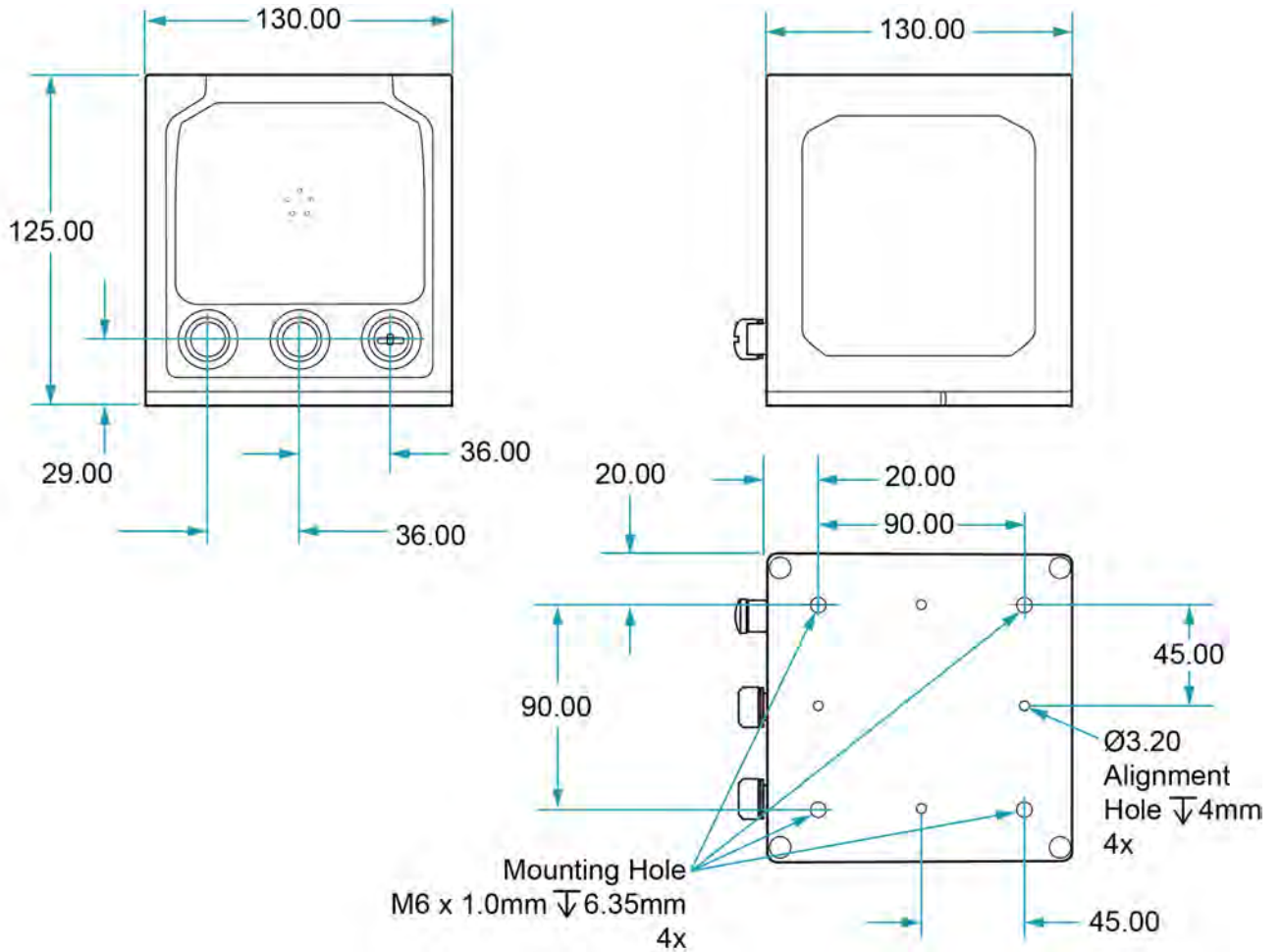
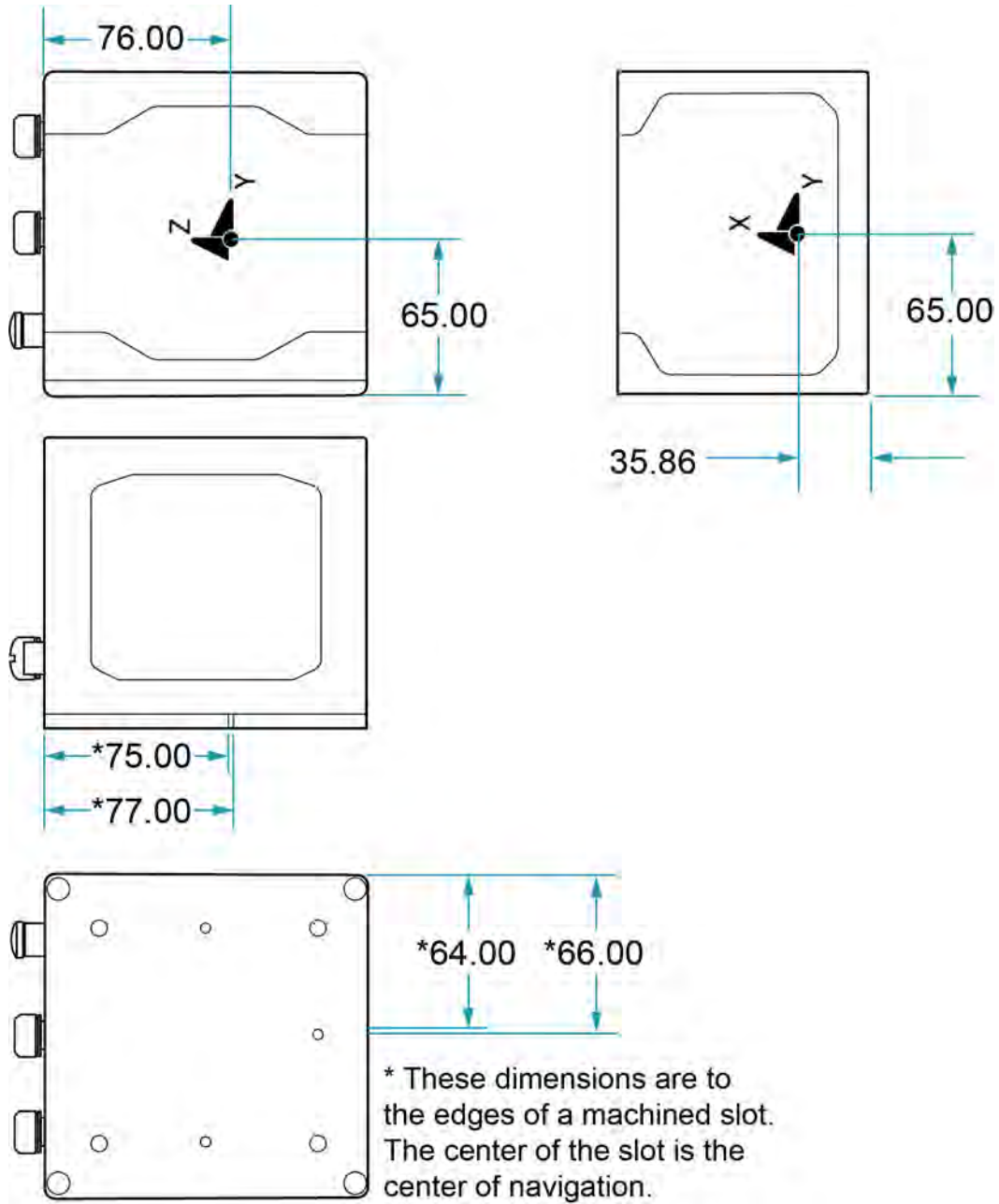

Figure 56: IMU-HG1900 centre of navigation



A.6.2 IMU-HG1900 sensor specifications

Table 69: IMU-HG1900 IMU performance

Gyroscope performance	
Technology	MEMS
Dynamic range	1000 °/s
Bias instability	1 °/hr
Angular random walk	0.06 °/√hr
Accelerometer performance	
Technology	RBA
Dynamic range	30 g
Bias instability	0.3 mg
Velocity random walk	0.02 m/s/√hr
Data rate	
IMU measurement	100 Hz

A.6.3 IMU-HG1900 electrical and environmental

Table 70: IMU-HG1900 electrical specifications

Electrical	
IMU power consumption	8 W (typical)
IMU input voltage	+10 to +34 VDC
Recommended fuse	1.8 A slow blow
IMU interface	RS-422
Connectors	
Power	SAL M12, 5 pin, male
Data	SAL M12, 5 pin, female
Wheel Sensor	SAL M12, 8 pin, male

Table 71: IMU-HG1900 environmental specifications

Environmental	
Operating temperature	-40°C to +55°C
Storage temperature	-40°C to +80°C
Humidity	MIL-STD-810G(Ch1), Method 507.6
Random vibrate	MIL-STD-810G(Ch1), Method 514.7 (2.0 g)
Environment	MIL-STD-810G(Ch1), Method 512.6 IEC 60529 IP67

A.6.4 IMU-HG1900 cables

IMU-HG1900 interface cable

The IMU-HG1900 uses the IMU Enclosure Interface Cable. Refer to *IMU Enclosure interface cable* on page 199 for details about this cable.

IMU-HG1900 power cable

The IMU-HG1900 uses the IMU Enclosure Power Cable. Refer to *IMU Enclosure power cable* on page 201 for details about this cable.

IMU-HG1900 wheel sensor cable

The IMU-HG1900 uses the IMU Enclosure Wheel Sensor Cable. Refer to *IMU Enclosure wheel sensor cable* on page 202 for details about this cable.

A.7 IMU-IGM-A1 and IMU-IGM-S1

This section contains the specifications for both the IMU-IGM-A1 and IMU-IGM-S1.

Table 72: IMU-IGM-A1 physical specifications

Physical	
Enclosure size	152.0 mm x 137.0 mm x 50.5 mm
Weight	475 g
Connectors	
MAIN	DB-15HD Female
AUX	DB-15HD Male

Table 73: IMU-IGM-S1 physical specifications

Physical	
Enclosure size	152.0 mm x 137.0 mm x 50.5 mm
Weight	500 g
Connectors	
MAIN	DB-15HD Female
AUX	DB-15HD Male

See the following sections for more information about the IMU-IGM-A1 or IMU-IGM-S1 IMUs.

- *IMU-IGM-A1 and IMU-IGM-S1 mechanical drawings* on the next page
- *IMU-IGM-A1 and IMU-IGM-S1 ports* on page 186
- *IMU-IGM-A1 and IMU-IGM-S1 sensor specifications* on page 188
- *IMU-IGM-A1 and IMU-IGM-S1 electrical and environmental* on page 189
- *IMU-IGM interface cable* on page 190

A.7.1 IMU-IGM-A1 and IMU-IGM-S1 mechanical drawings



In the following diagrams, the dimensions are in millimetres.

Figure 57: IMU-IGM-A1 dimensions

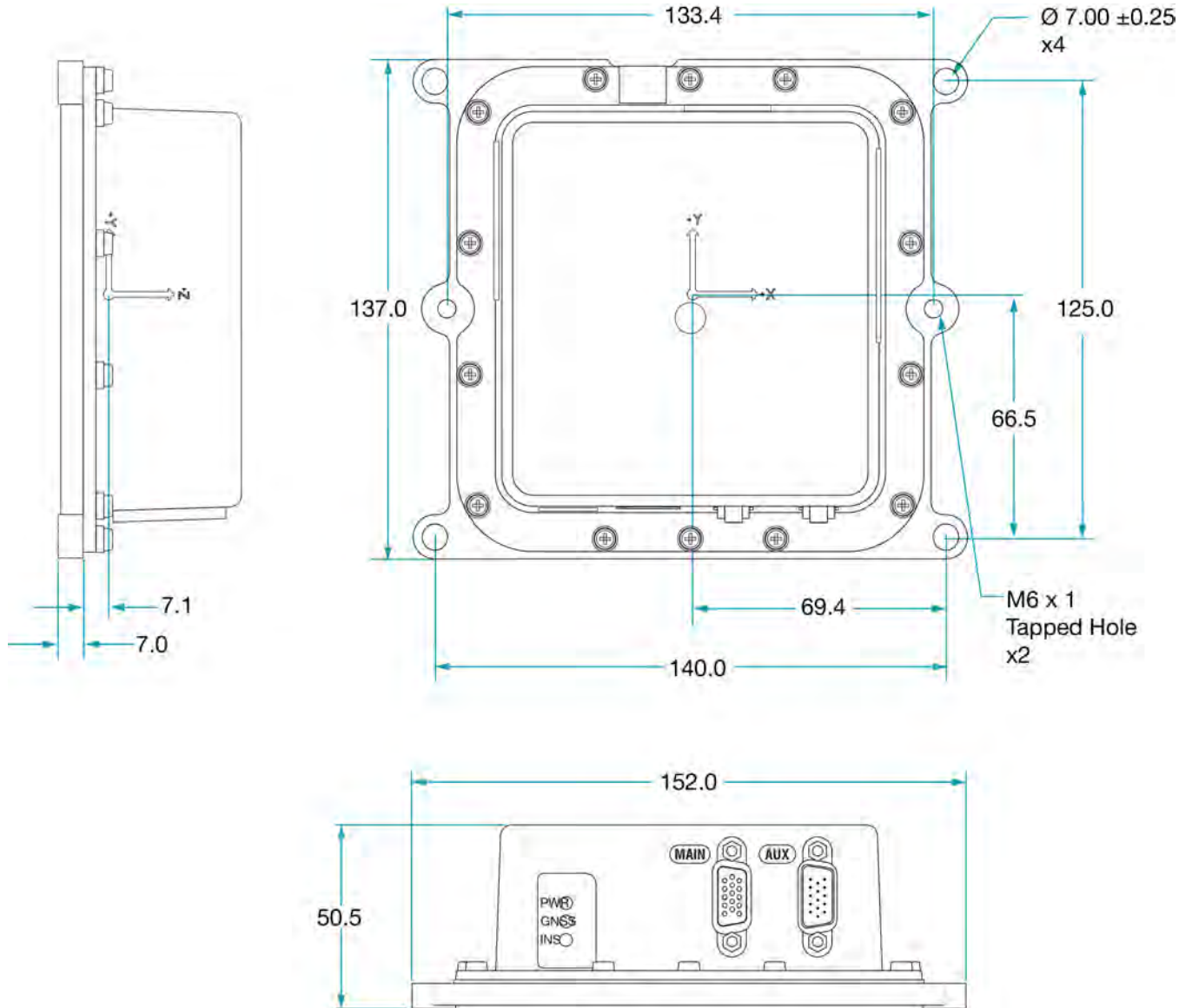

The centre of navigation is at the location marked by the axis labels on the enclosure and indicated on the drawing above. It is not at the depression in the enclosure cover.

Figure 58: IMU-IGM-S1 dimensions

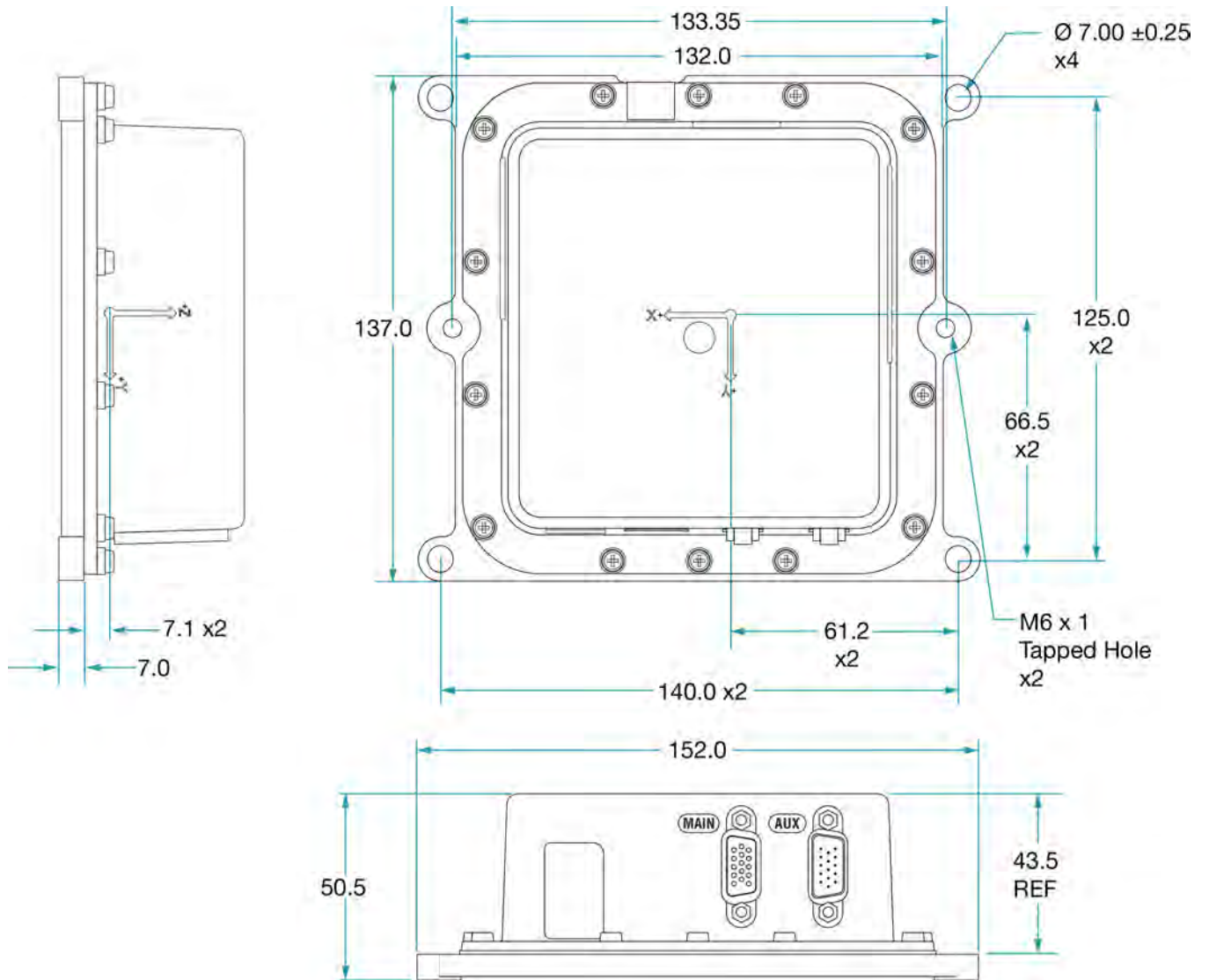

The centre of navigation is at the location marked by the axis labels on the enclosure and indicated on the drawing above. It is not at the depression in the enclosure cover.

A.7.2 IMU-IGM-A1 and IMU-IGM-S1 ports

Table 74: IMU-IGM-A1 and IMU-IGM-S1 Main port pinout

Pin #	Label	Description
1	MIC_TX/MIC_TX+	MODE2 open: MIC port transmit (RS-232) MODE2 low: MIC port transmit positive (RS-422)
2	MIC_TX-	MODE2 open: No connection MODE2 low: MIC port transmit negative (RS-422)
3	DGND	Digital ground
4	V+	Power supply input, positive
5	V-	Power supply input, negative
6	MIC_RX/MIC_RX+	MODE2 open: MIC port receiver (RS-232) MODE2 low: MIC port receive positive (RS-422)
7	MIC_RX-	MODE2 open: No connection MODE2 low: MIC port receive negative (RS-422)
8	DGND	Digital ground
9	Reserved	Reserved
10	Reserved	Reserved
11	DGND	Digital ground
12	Reserved	Reserved
13	MODE2	Mode 2 input, controls MIC port standard
14	Reserved	Reserved
15	Reserved	Reserved

Table 75: IMU-IGM-A1 and IMU-IGM-S1 AUX port pinout

Pin #	Label	Description
1	ODM_A+	Wheel sensor input A positive
2	ODM_B+	Wheel sensor input B positive (No connection on IMU-IGM-S1)
3	Reserved	Reserved
4	WS_VOUT	Wheel sensor output voltage (12 VDC)
5	DGND	Digital ground
6	ODM_A-	Wheel sensor input A negative

Pin #	Label	Description
7	ODM_B-	Wheel sensor input B negative (No connection on IMU-IGM-S1)
8	Reserved	Reserved
9	DGND	Digital ground
10	Reserved	Reserved
11	Reserved	Reserved
12	Reserved	Reserved
13	Reserved	Reserved
14	Reserved	Reserved
15	DGND	Digital ground

A.7.3 IMU-IGM-A1 and IMU-IGM-S1 sensor specifications

Table 76: IMU-IGM-A1 IMU performance

Gyroscope performance	
Technology	MEMS
Gyro input range	± 450 °/s
In run gyro rate bias stability	6.25 °/hr
Angular random walk	0.3 °/ $\sqrt{\text{hr}}$
Accelerometer performance	
Technology	MEMS
Accelerometer range	± 18 g
In run accelerometer bias stability	0.1 mg
Velocity random walk	0.029 m/s/ $\sqrt{\text{hr}}$
Data rate	
IMU measurement	200 Hz

Table 77: IMU-IGM-S1 IMU performance

Gyroscope performance	
Technology	MEMS
Dynamic range	400 °/s
Bias instability	0.3 °/hr
Angular random walk	0.15 °/ $\sqrt{\text{hr}}$
Accelerometer performance	
Technology	MEMS
Dynamic range	10 g
Bias instability	0.04 mg
Velocity random walk	0.07 m/s/ $\sqrt{\text{hr}}$
Data rate	
IMU measurement	125 Hz

A.7.4 IMU-IGM-A1 and IMU-IGM-S1 electrical and environmental**Table 78: IMU-IGM-A1 electrical specifications**

Electrical	
Input voltage	10 - 30 VDC
Power consumption	2.5 W (typical)
Recommended fuse	0.5 A slow blow

Table 79: IMU-IGM-A1 environmental specifications

Environmental	
Temperature, operational	-40°C to +65°C
Temperature, storage	-50°C to +80°C
Humidity	95% Non-condensing

Table 80: IMU-IGM-S1 electrical specifications

Electrical	
Input voltage	10 - 30 VDC
Power consumption	<4.6 W (typical)
Recommended fuse	1.0 A slow blow

Table 81: IMU-IGM-S1 environmental specifications

Environmental	
Temperature, operational	-40°C to +65°C
Temperature, storage	-50°C to +80°C
Humidity	95% Non-condensing

A.7.5 IMU-IGM interface cable

The NovAtel part number for the IMU-IGM interface cable is 01019016. This cable provides power to the IMU-IGM and communication signals between the IMU-IGM and the OEM7 family receiver.



In the following diagram, the dimensions are in millimetres.

Figure 59: IMU-IGM interface cable

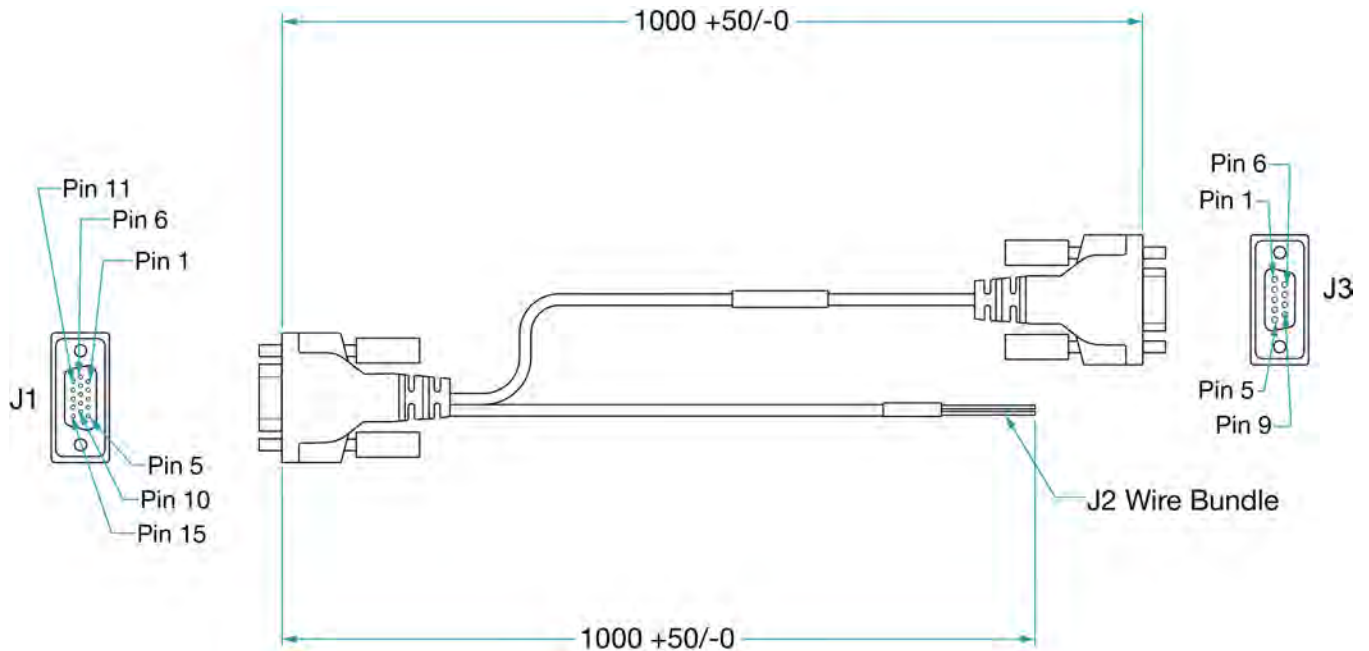

Table 82: IMU-IGM interface cable pinout descriptions

J1 MAIN pin #	Function	J2 wire bundle label	J3 MIC port pin #
1	MIC Port Transmit/Transmit+ (RS-422)		2
2	MIC Port Transmit- (RS-422)		8
3	Digital Ground		
4	Battery +	BATT+	
5	Digital Ground	BATT-	
6	MIC Port Receive/Receive+ (RS-422)		3
7	MIC Port Receive- (RS-422)		7
8	Digital Ground		5
9	Reserved		

J1 MAIN pin #	Function	J2 wire bundle label	J3 MIC port pin #
10	Reserved		
11	Digital Ground		
12	Reserved		
13	MODE 2	MODE 2	
14	Reserved		
15	Reserved		



The MIC port can operate as either an RS-232 or RS-422 serial port.

- To set the MIC port to RS-232, leave the MODE 2 pin open/unconnected.
- To set the MIC port to RS-422, tie the MODE 2 pin low.

Custom cable recommendations

The tables below provide recommendations for creating custom cables to replace the IMU-IGM interface cable (01019016).

Table 83: Connectors

Connector	Description
J1	DB-15HD, male
J2	DB-9, female

Table 84: Maximum cable length

IMU	RS-232	RS-422
IMU-IGM-A1, IMU-IGM-S1	< 1.2 metres	< 50 metres

A.8 IMU-ISA-100C

The IMU-ISA-100C contains an ISA-100C IMU.

Table 85: IMU-ISA-100C physical specifications

Physical	
IMU enclosure size	180 mm x 150 mm x 137 mm
IMU enclosure weight	5.0 kg

See the following sections for more information about the IMU-ISA-100C IMU.

- *IMU-ISA-100C mechanical drawings* on the next page
- *Optional side mounting holes* on page 195
- *IMU-ISA-100C sensor specifications* on page 197
- *IMU-ISA-100C electrical and environmental* on page 198
- *IMU Enclosure interface cable* on page 199
- *IMU Enclosure power cable* on page 201
- *IMU Enclosure wheel sensor cable* on page 202

A.8.1 IMU-ISA-100C mechanical drawings



In the following diagrams, the dimensions are in millimetres.

Figure 60: IMU-ISA-100C dimensions

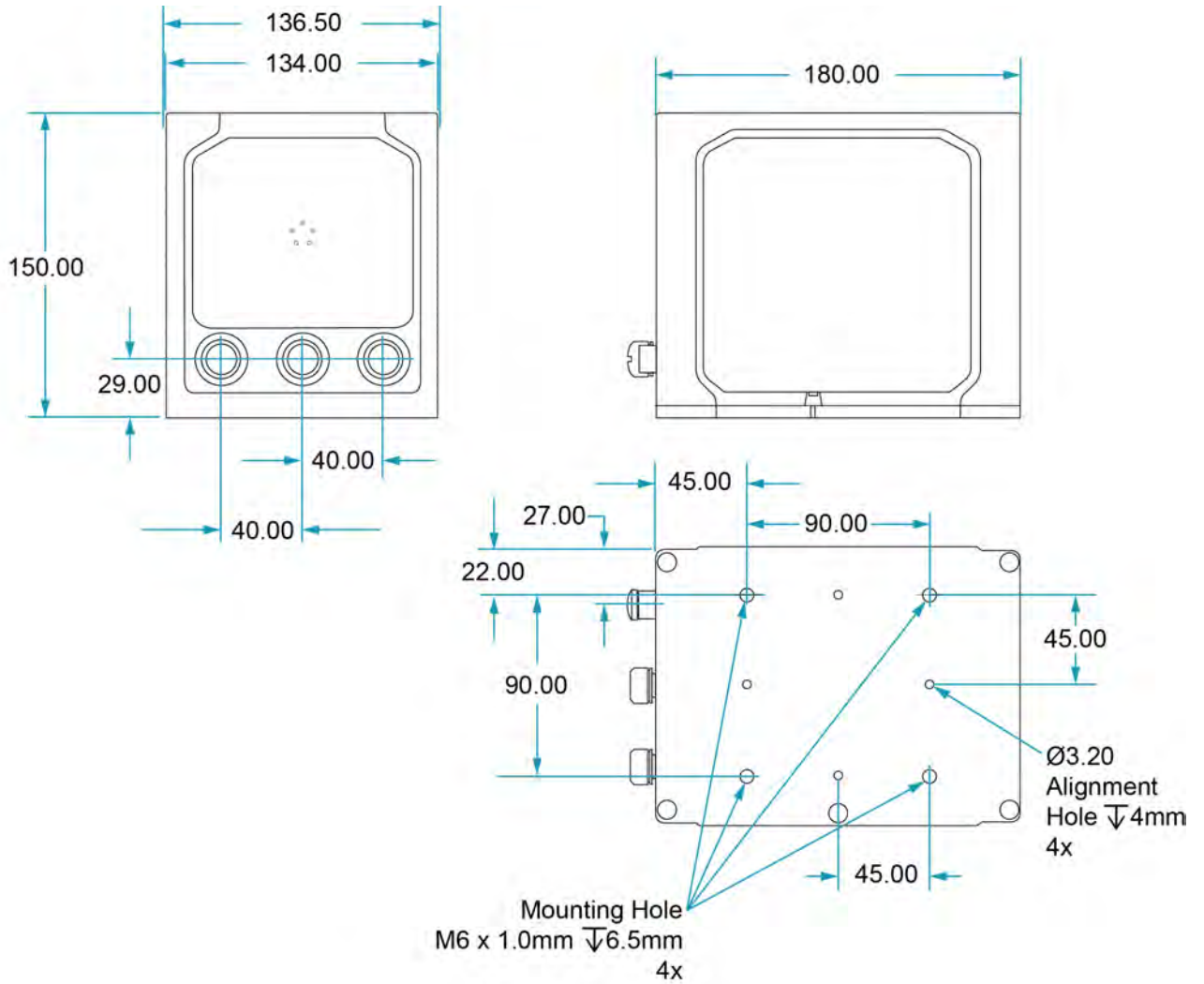
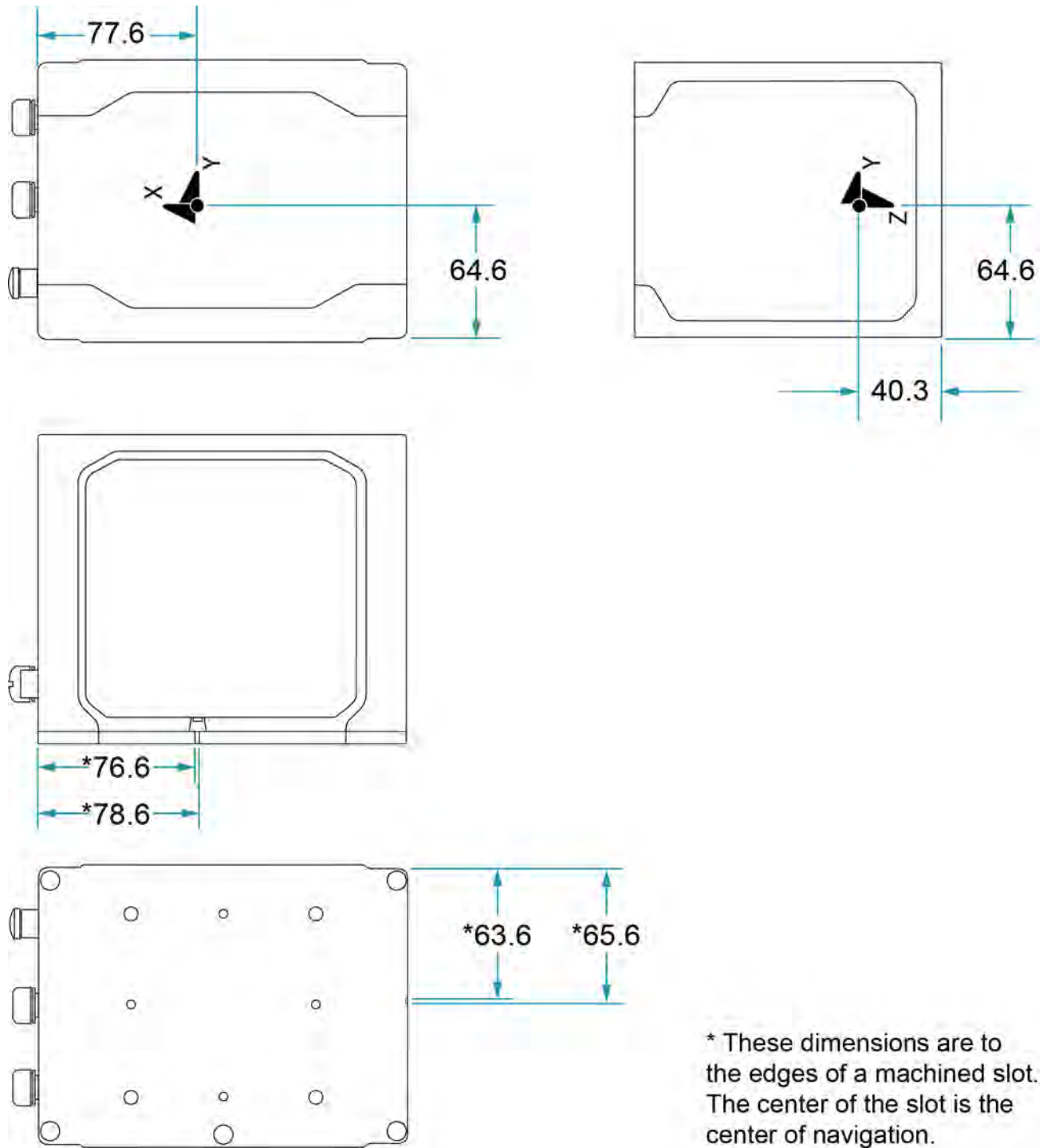

Figure 61: IMU-ISA-100C centre of navigation



A.8.2 Optional side mounting holes

There are mounting and alignment holes on both sides of the IMU enclosure to allow the IMU to be mounted on its side. These holes have the same pattern and spacing as the mounting and alignment holes on the bottom of the IMU enclosure.

To access these holes, the NovAtel label must be removed from the side of the enclosure. A small notch on the side of enclosure allows you to insert a small flat blade screw under the label to start lifting the label.



In the following diagram, the dimensions are in millimetres.

Figure 62: Optional side mounting holes

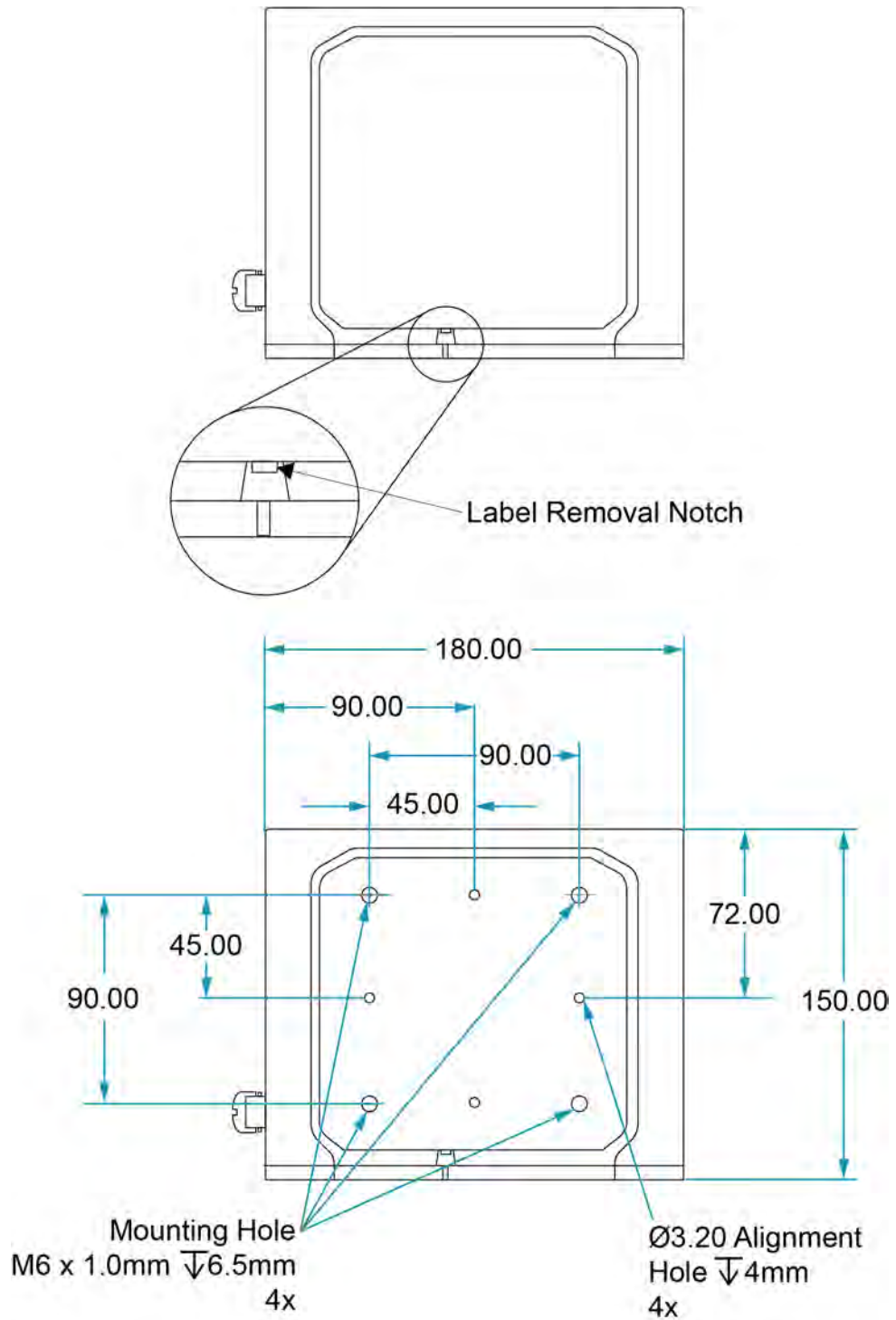

A.8.3 IMU-ISA-100C sensor specifications

Table 86: IMU-ISA-100C IMU performance

Gyroscope performance	
Technology	FOG
Dynamic range	495 °/s
Bias instability ¹	0.05 °/hr
Angular random walk (typical) ¹	0.005 °/√hr
Accelerometer performance	
Technology	MEMS
Dynamic range	10 g
Bias instability ¹	0.1 mg
Velocity random walk (typical) ¹	0.018 m/s/√hr
Data rate	
IMU measurement	200 Hz

1. From room temperature Allan variance method.

A.8.4 IMU-ISA-100C electrical and environmental**Table 87: IMU-ISA-100C electrical specifications**

Electrical	
IMU power consumption	18 W (typical)
IMU input voltage	+10 to +34 VDC
Recommended fuse	2.5 A slow blow
IMU interface	RS-422
Connectors	
Power	SAL M12, 5 pin, male
Data	SAL M12, 5 pin, female
Wheel Sensor	SAL M12, 8 pin, male

Table 88: IMU-ISA-100C environmental specifications

Environmental	
Operating temperature	-40°C to +55°C
Storage temperature	-40°C to +85°C
Humidity	MIL-STD-810G, Method 507.5
Random vibrate	MIL-STD-810G, Method 514.6 (2.0 g)
Environmental	IEC 60529 IP67

A.8.5 IMU Enclosure interface cable

The NovAtel part number for the IMU Enclosure interface cable is 01019319 (see *Figure 63: IMU Enclosure interface cable* below). This cable enables communication between the receiver and the IMU.

i This cable is used for all versions of the IMU Enclosure (IMU-ISA-100C, IMU-LN200, IMU-HG1900 and IMU-μIMU-IC).

i In the following diagram, the dimensions are in millimetres.

Figure 63: IMU Enclosure interface cable

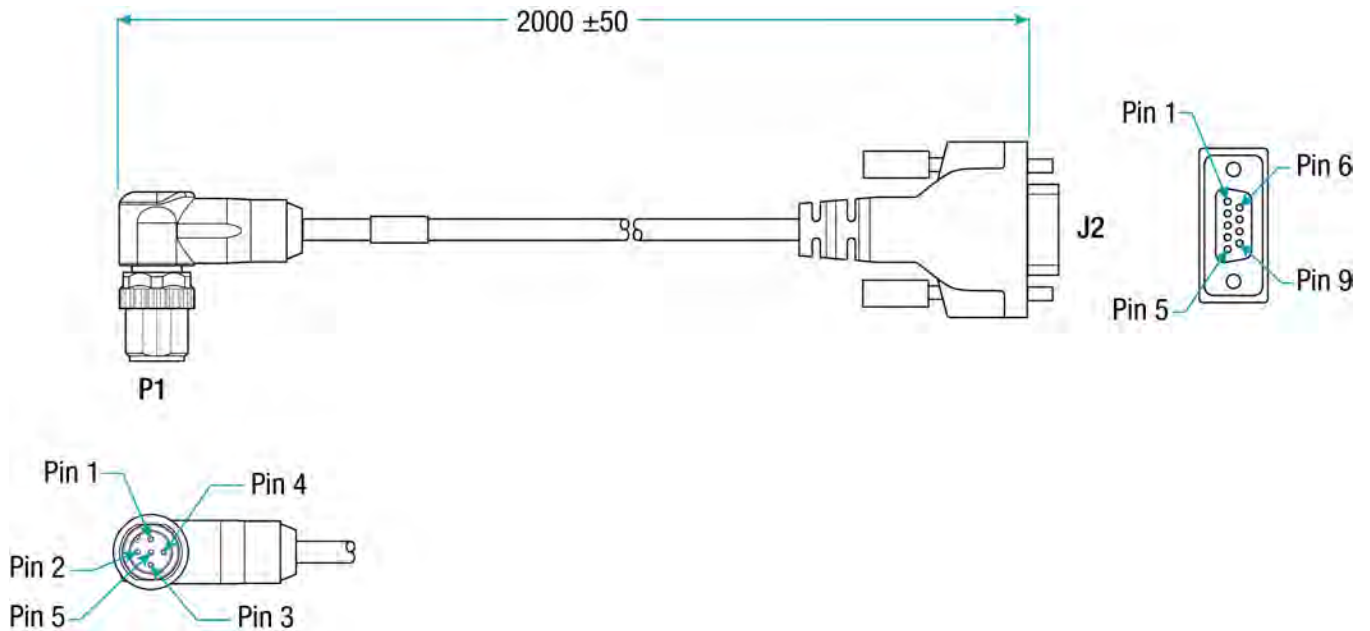

Table 89: IMU Enclosure interface cable pinout

P1 pins (M12)	Function	J2 pins (DB9)
1	TX+	2
2	RX+	3
3	TX-	8
4	RX-	7
5	GND	5
Shield	Shield	Shield

Custom cable recommendations

The tables below provide recommendations for creating custom cables to replace the IMU Enclosure interface cable (01019319).

Table 90: Connectors

Connector	Description
P1	M12x1, 5 position, male
J2	DB-9, female

Table 91: Maximum cable length

IMU	RS-422
IMU-ISA-100C IMU-LN200 IMU-HG1900 IMU- μ IMU-IC	< 50 metres

A.8.6 IMU Enclosure power cable

The NovAtel part number for the IMU Enclosure power cable is 60723136 (see *Figure 64: IMU Enclosure power cable* below). This cable provides power to the IMU from an external power source.

i This cable is used for all versions of the IMU Enclosure (IMU-ISA-100C, IMU-LN200, IMU-HG1900 and IMU- μ IMU-IC).

i In the following diagram, the dimensions are in millimetres.

Figure 64: IMU Enclosure power cable

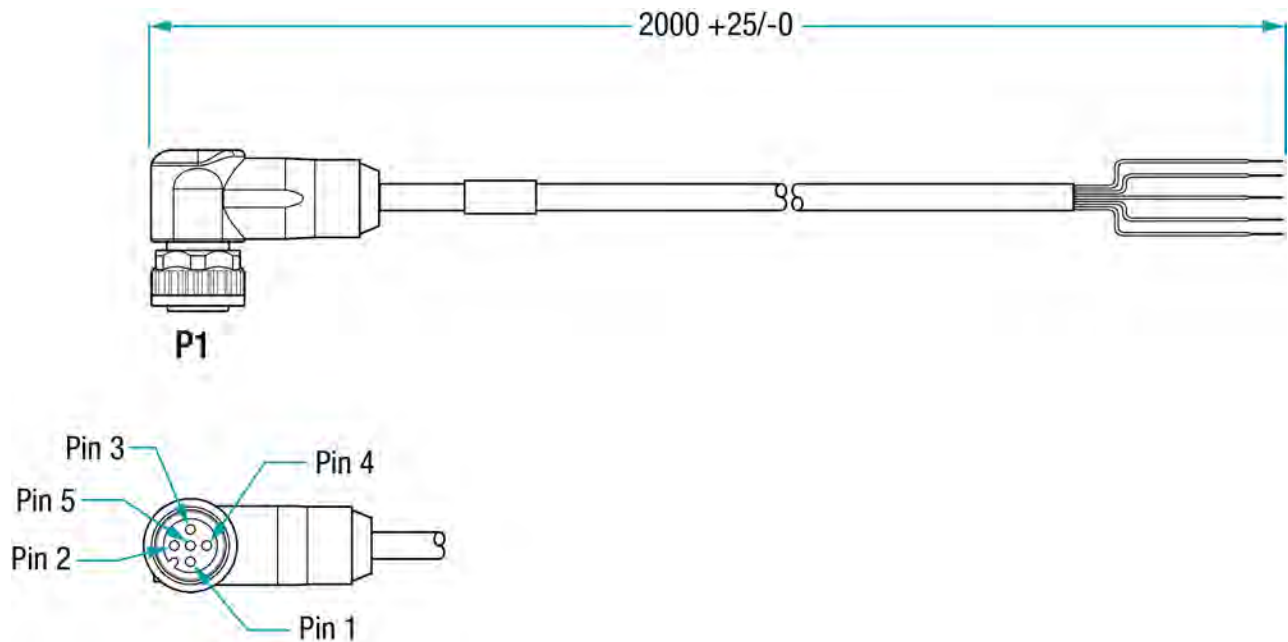

Table 92: IMU Enclosure power cable pinout

P1 pins (M12)	Function	Bare wire colour
1	VIN-	Brown
2	VIN+	White
3	VIN+	Blue
4	VIN-	Black
5	Chassis Ground	Grey

i This cable uses a M12x1, 5 position, female connector.

A.8.7 IMU Enclosure wheel sensor cable

The NovAtel part number for the IMU Enclosure wheel sensor cable is 60723137 (see *Figure 65: IMU Enclosure wheel sensor cable* below). This cable enables communication between the IMU and the wheel sensor.



This cable is used for all versions of the IMU Enclosure (IMU-ISA-100C, IMU-LN200, IMU-HG1900 and IMU-μIMU-IC).



In the following diagram, the dimensions are in millimetres.

See also *DMI connected to an IMU* on page 122.

Figure 65: IMU Enclosure wheel sensor cable

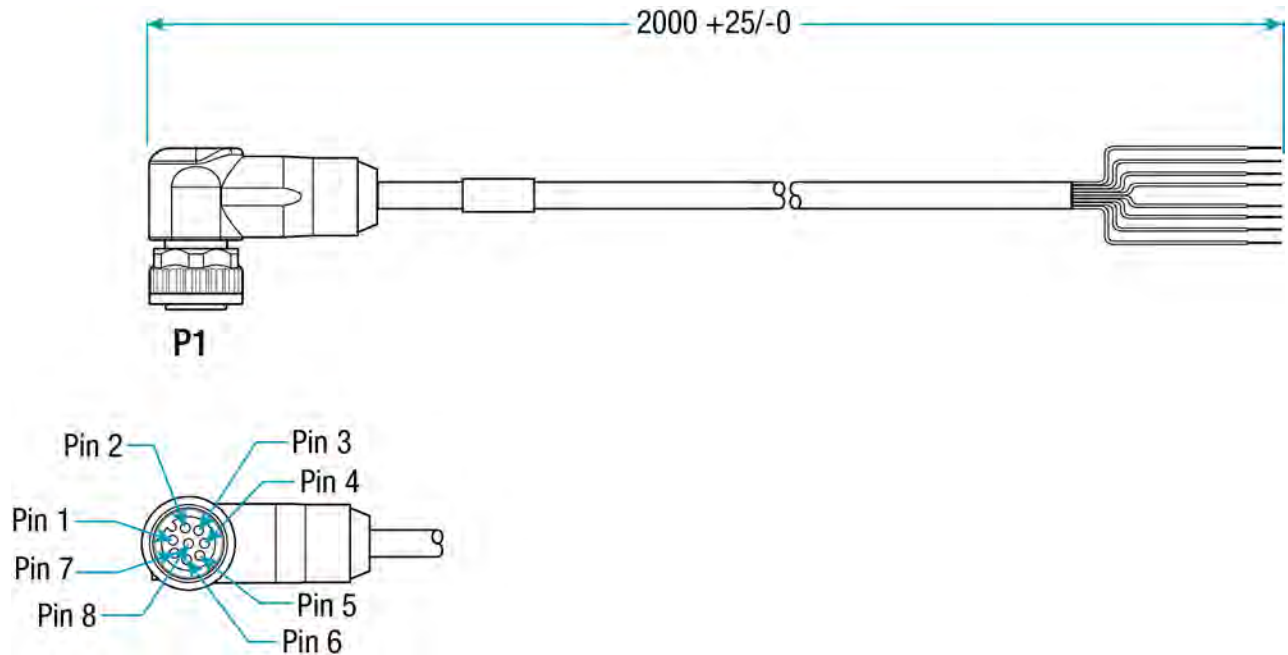

Table 93: IMU Enclosure wheel sensor cable pinout

P1 pins (M12)	Function	Bare wire colour
1	A+	White
2	B+	Brown
3	Chassis Ground	Green
4	A-	Yellow
5	B-	Grey
6	Chassis Ground	Pink

P1 pins (M12)	Function	Bare wire colour
7	Reserved	Blue
8	Reserved	Red

Custom cable recommendations

The tables below provide recommendations for creating custom cables to replace the IMU Enclosure Wheel Sensor cable (60723137).

Table 94: Connectors

Connector	Description
P1	M12x1, 8 position, female
J2	DB-9, female

Table 95: Maximum cable length

IMU	RS-422
IMU-ISA-100C IMU-LN200 IMU-HG1900 IMU- μ IMU-IC	< 50 metres

A.9 IMU-KVH1750

Table 96: IMU-KVH1750 physical specifications

Physical	
Enclosure size (Ø x H)	88.9 mm X 73.7 mm
Weight	<0.7 kg

See the following sections for more information about the IMU-KVH1750.

- *IMU-KVH1750 mechanical drawings* on the next page
- *IMU-KVH1750 sensor specifications* on page 210
- *IMU-KVH1750 electrical and environmental* on page 211
- *IMU-KVH1750 and IMU-P1750 cable* on page 212

A.9.1 IMU-KVH1750 mechanical drawings



In the following diagrams, the dimensions are in millimetres [inches].

Figure 66: IMU-KVH1750 bottom view

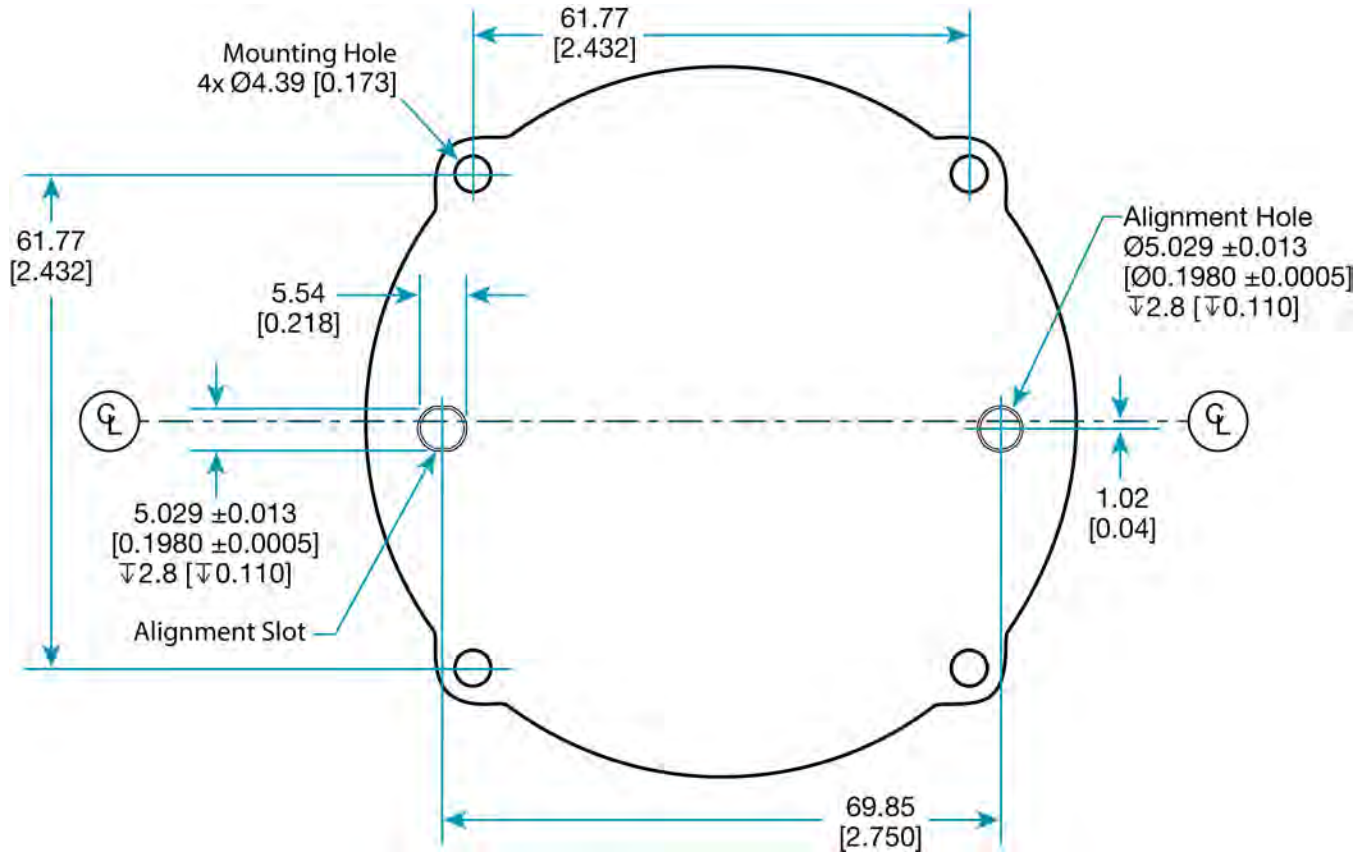

Figure 67: IMU-KVH1750 top view

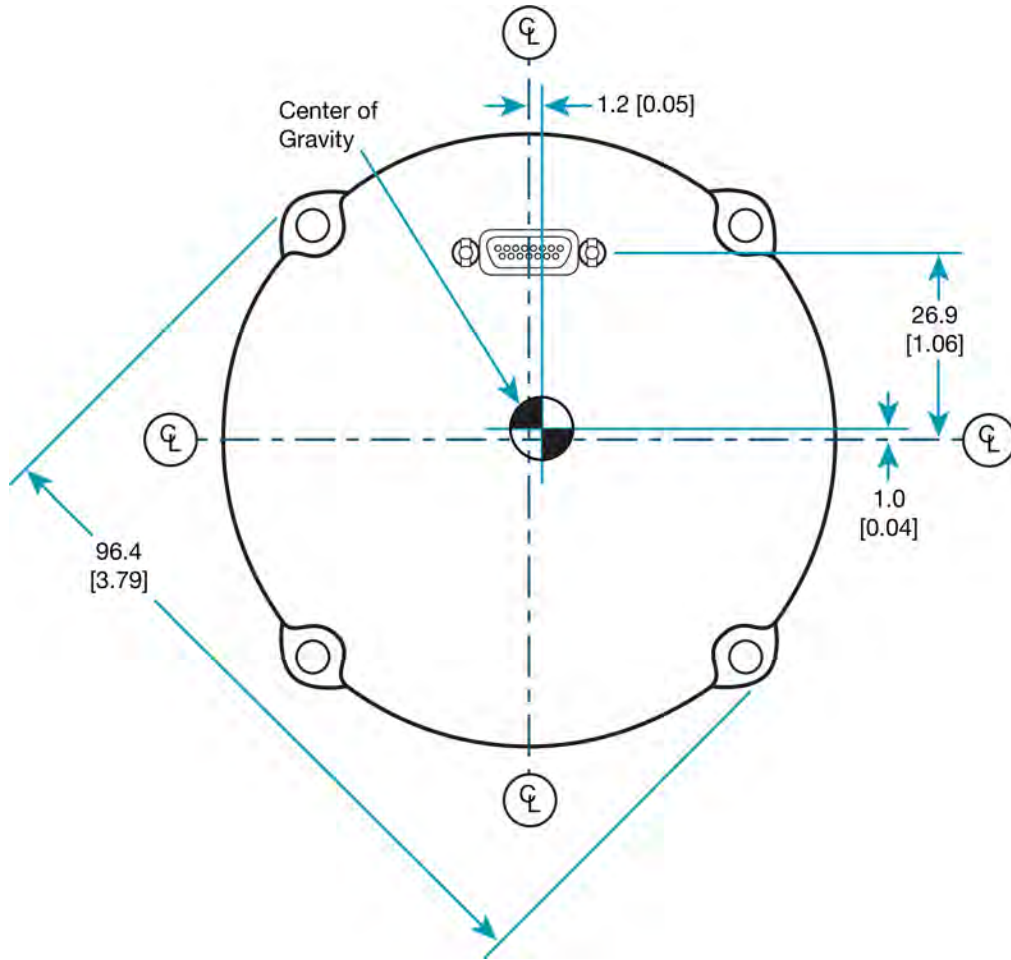

Figure 68: IMU-KVH1750 side view

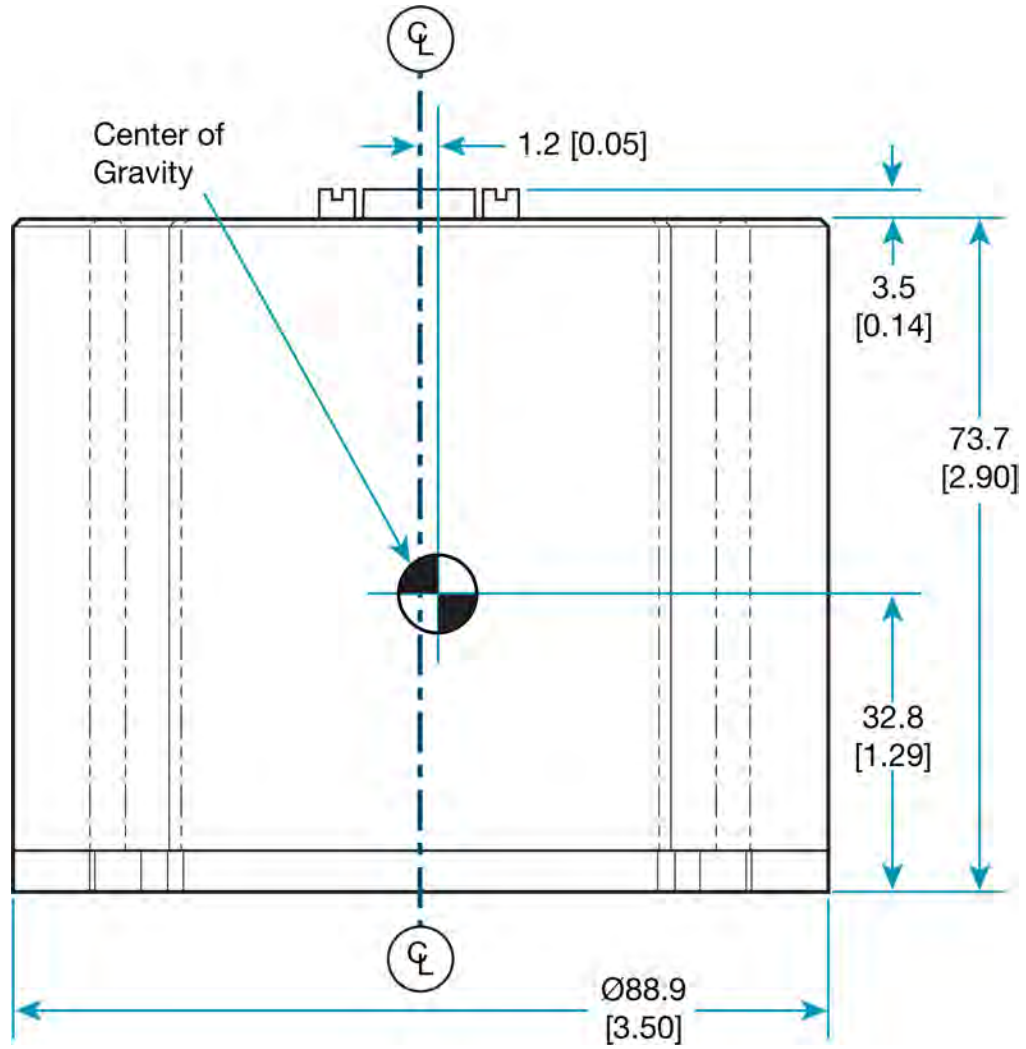
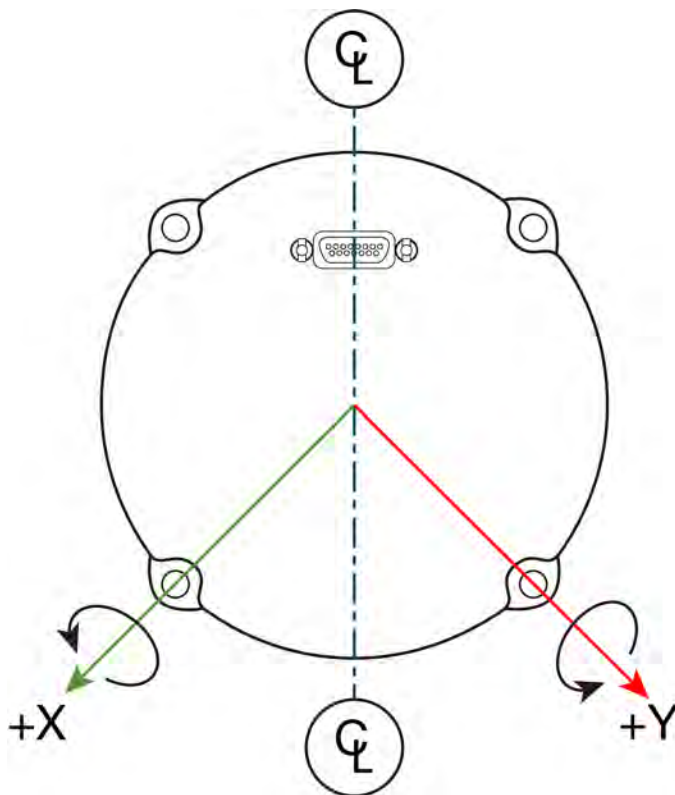
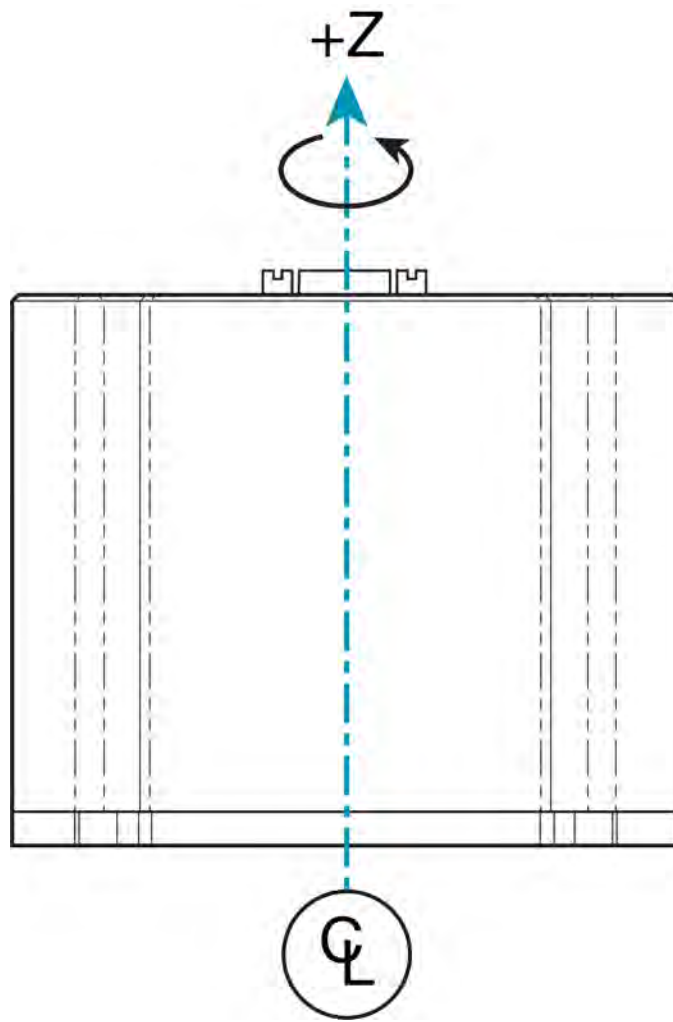

Figure 69: IMU-KVH1750 gyro axes





A.9.2 IMU-KVH1750 sensor specifications

Table 97: IMU-KVH1750 performance

Gyroscope performance	
Maximum input rate	± 490 °/s
Bias stability (constant temperature)	0.05°/hr (typical) 0.1°/hr (max)
Bias temperature sensitivity (full temp.)	0.7°/hr (typical) 1°/hr (max)
Bias offset (at 25° C)	± 2 °/hr
Scale factor (nominal)	1 \pm 0.2%
Scale factor non-linearity (at 25° C)	≤ 50 ppm
Scale factor temperature sensitivity	≤ 200 ppm
Angular random walk	≤ 0.012 °/ $\sqrt{\text{hr}}$
Input axis misalignment	± 0.4 mrad
Accelerometer performance	
Maximum input	± 10 g
Bias stability (at 25° C)	≤ 0.05 mg
Scale factor temperature sensitivity	≤ 100 ppm/°C (typical) 250 ppm/°C (max)
Velocity random walk	0.12 mg/ $\sqrt{\text{Hz}}$
Input axis misalignment	± 1.0 mrad
Data rate	
IMU measurement	200 Hz

A.9.3 IMU-KVH1750 electrical and environmental**Table 98: IMU-KVH1750 electrical specifications**

Electrical	
Input voltage	9 - 36 VDC
Power consumption	5W (typical), 8W (max)
Recommended fuse	1.25 A slow blow
Turn-on time (room temp.)	≤1.25 seconds
Full performance time (room temp.)	≤60 seconds
IMU interface	RS-422
Connectors	
Power and I/O	15-pin Micro-D (male)

Table 99: IMU-KVH1750 environmental specifications

Environmental	
Temperature, operational	-40°C to +75°C
Temperature, non-operational	-50°C to +85°C
Vibration, operational	8 g rms, 20 Hz -2 kHz
Vibration, non-operational	12 g rms, 20 Hz -2 kHz
Shock, operational	9 g (11 ms, sawtooth)
Shock, non-operational	40 g (11 ms, sawtooth)

A.9.4 IMU-KVH1750 and IMU-P1750 cable

The NovAtel part number for the IMU-KVH1750 and IMU-P1750 cable is 01019211. This cable provides power to the IMU from an external power source and enables communication between the receiver and the IMU.



In the following diagram, the dimensions are in millimetres.

Figure 70: IMU-KVH1750 and IMU-P1750 cable

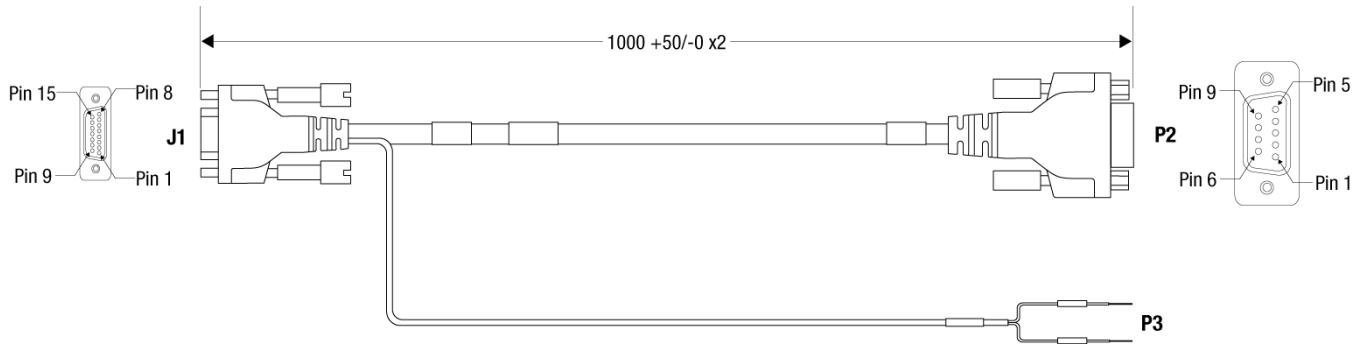

Table 100: IMU-KVH1750 and IMU-P1750 connector pinout descriptions

J1 (15 pin Micro D female)		P2 (female DB9)		P3
Pin #	Signal name	Pin #	Signal name	Labels
1	TX+	2	RX+	
2	TX-	8	RX-	
3	RX-	7	TX-	
4	RX+	3	TX+	
5	Reserved			
6	Reserved			
7	Reserved			
8	Reserved			
9	Power Return			PWR-
10	VDC Power			PWR+
11	MSync	1	IMU Event Out (Sync)	
12	TOV-Out	9	Event In	
13	Reserved			
14	Reserved			
15	Signal Ground	5	Signal Ground	
Shell	Chassis Ground	Shell	Chassis Ground	



A hardware change by KVH regarding KVH1750 IMUs (manufactured after November 2015) expect a differential MSYNC signal input (J1 (15 pin micro D female) of the IMU: Pin 11 MSync+, Pin 7 MSync-). This was previously a single ended input signal on Pin 11 only. The NovAtel VARF signal used to provide the MSYNC to the IMU remains single ended, however significant testing has been completed with the existing IMU-KVH1750 Cable (01019211) in safe environments (no interference sources). No issues or failures have been observed. There are no plans to modify NovAtel cables at this time. However, for any custom or OEM cable solutions, it is recommended to follow KVH guidelines in providing a differential MSYNC signal, converting the VARF to differential and properly shielding for optimal reliability.

Custom cable recommendations

The tables below provide recommendations for creating custom cables to replace the IMU-KVH1750 and IMU-P1750 cable (01019211).

Table 101: Connectors

Connector	Description
J1	Micro-D, 15-pin, female
J2	DB-9, female

Table 102: Maximum cable length

IMU	RS-422
IMU-KVH1750	< 1.5 metres
IMU-P1750	

A.10 IMU-P1750

Table 103: IMU-P1750 physical specifications

Physical	
Enclosure size (Ø x H)	88.9 mm X 73.7 mm
Weight	0.7 kg

See the following sections for more information about the IMU-P1750.

- *IMU-P1750 mechanical drawings* on the next page
- *IMU-P1750 sensor specifications* on page 220
- *IMU-P1750 electrical environmental* on page 221
- *IMU-KVH1750 and IMU-P1750 cable* on page 212

A.10.1 IMU-P1750 mechanical drawings



In the following diagrams, the dimensions are in millimetres [inches].

Figure 71: IMU-P1750 bottom view

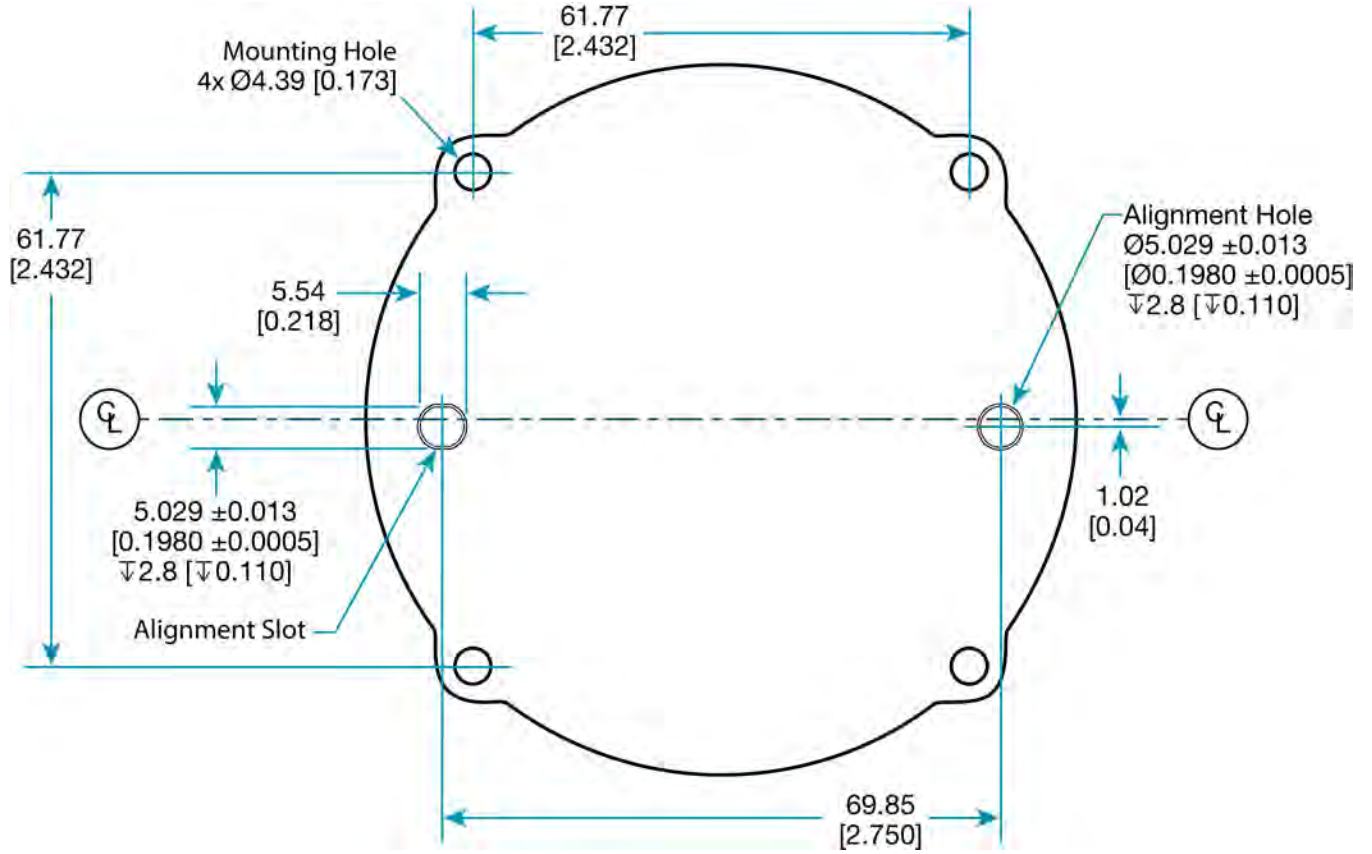

Figure 72: IMU-P1750 top view

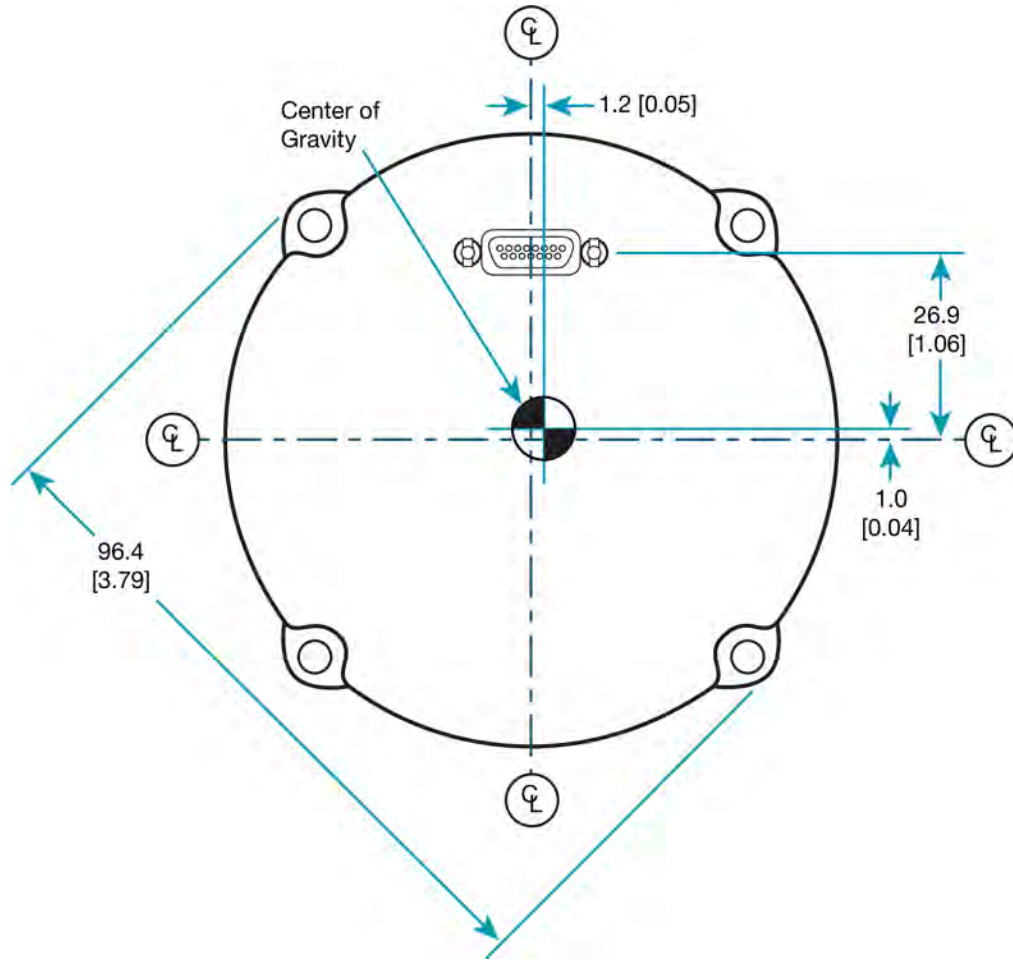

Figure 73: IMU-P1750 side view

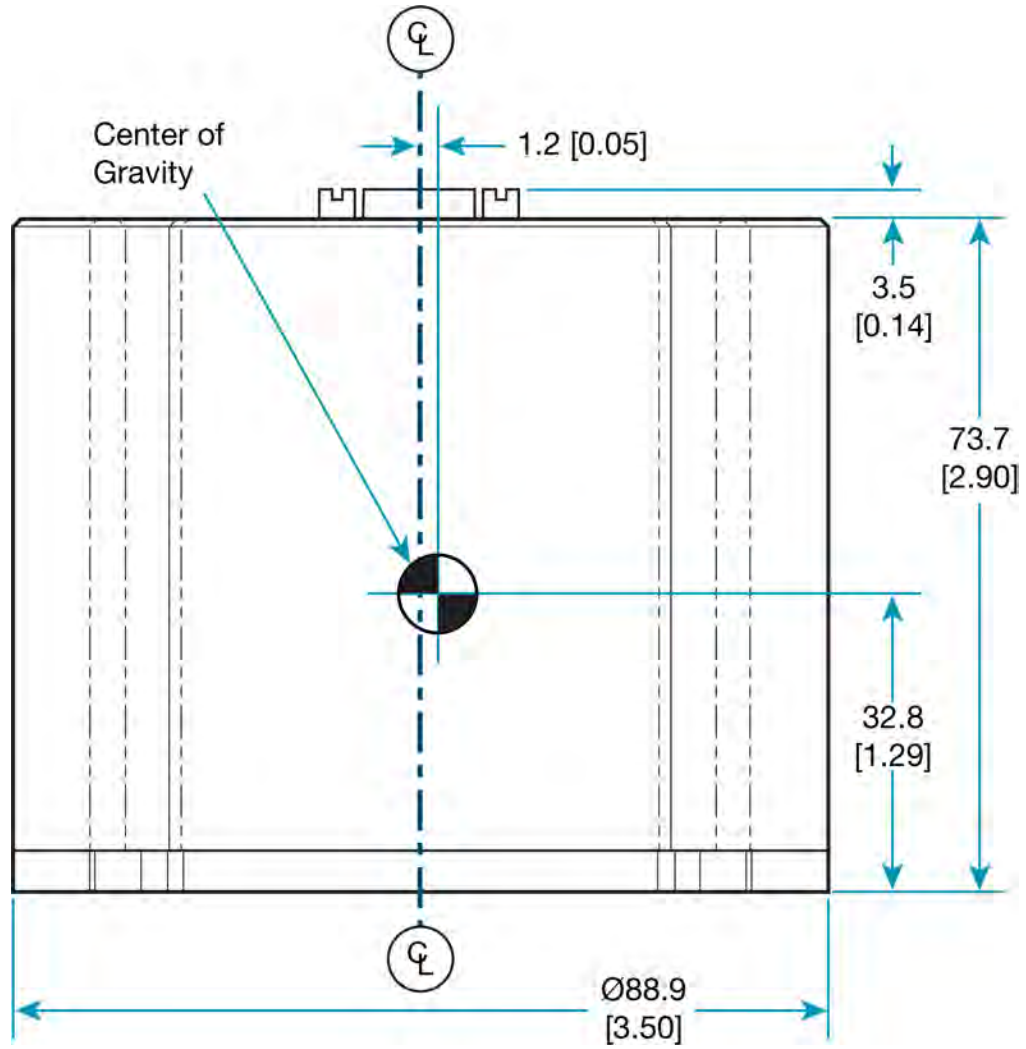
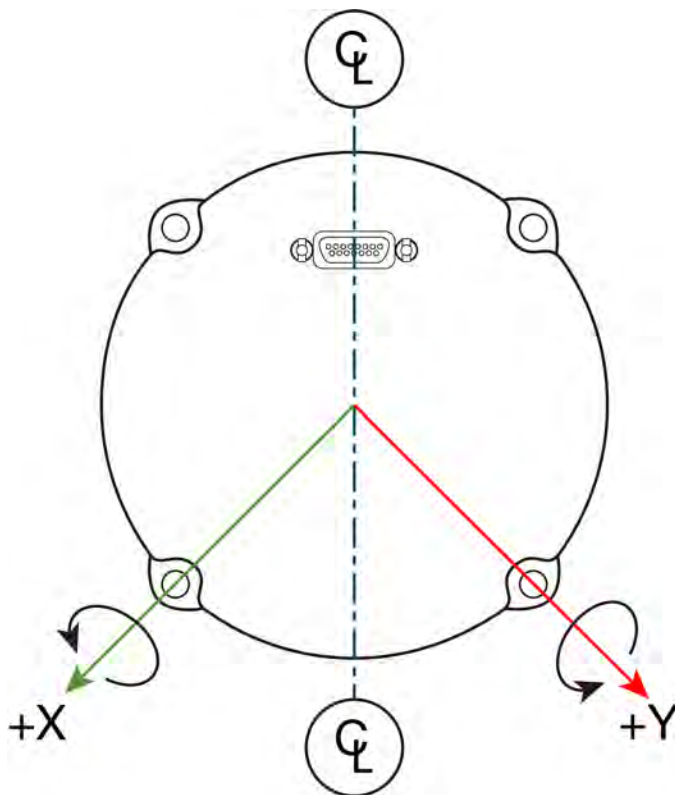
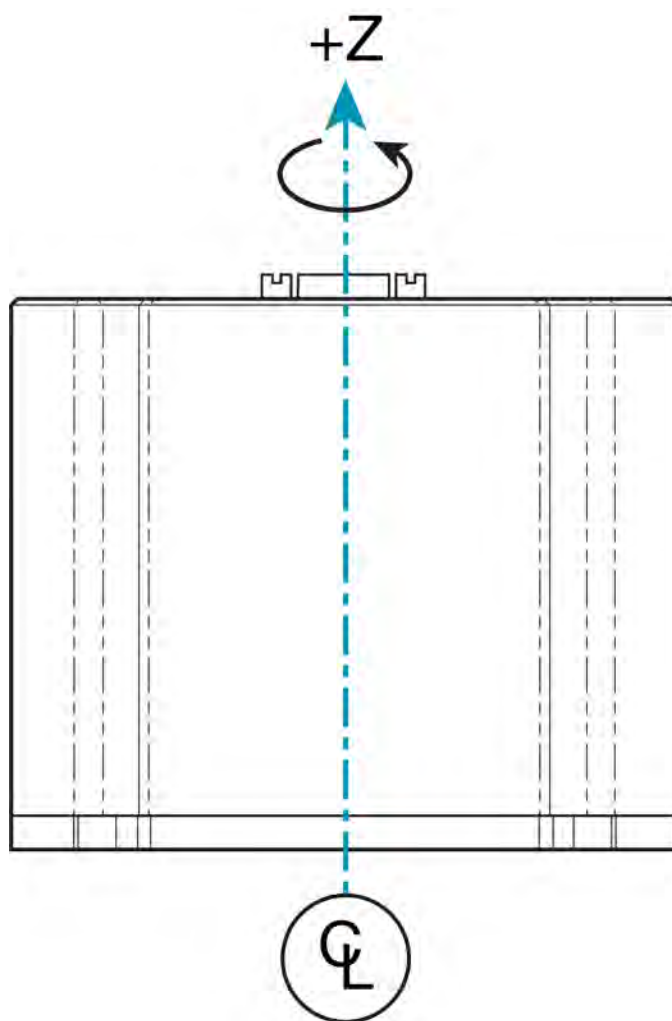

Figure 74: IMU-P1750 gyro axes





A.10.2 IMU-P1750 sensor specifications

Table 104: IMU-P1750 performance

Gyroscope performance	
Technology	FOG
Dynamic range	490 °/s
Bias instability	0.05 °/hr
Angular random walk	0.012 °/√hr
Accelerometer performance	
Technology	MEMS
Dynamic range	16 g
Bias instability	0.024 mg
Velocity random walk	0.032 m/s/√hr
Data rate	
IMU measurement	200 Hz

A.10.3 IMU-P1750 electrical environmental**Table 105: IMU-P1750 electrical specifications**

Electrical	
Input voltage	9 - 36 VDC
Power consumption	5W (typical), 8W (max)
Recommended fuse	1.25 A slow blow
IMU interface	RS-422
Connectors	
Power and I/O	15-pin Micro-D (male)

Table 106: IMU-P1750 environmental specifications

Environmental	
Temperature, operational	-40°C to +75°C
Temperature, non-operational	-50°C to +85°C
Vibration, operational	8 g rms, (20 - 2000 Hz random)
Vibration, non-operational	12.5 g rms, (20 - 2000 Hz random)
Shock, operational	9 g (11 ms, sawtooth)
Shock, non-operational	40 g (11 ms, sawtooth)

A.11 IMU-LN200

The IMU-LN200 contains an LN200 or LN200C IMU.

Table 107: IMU-LN200 physical specifications

Physical	
IMU enclosure size	150 mm x 134 mm x 134 mm
IMU enclosure weight	3.2 kg

See the following sections for more information about the IMU-LN200.

- *IMU-LN200 mechanical drawings* on the next page
- *IMU-LN200 sensor specifications* on page 225
- *IMU-LN200 electrical and environmental* on page 226
- *IMU-LN200 cables* on page 226

A.11.1 IMU-LN200 mechanical drawings



In the following diagrams, the dimensions are in millimetres.

Figure 75: IMU-LN200 dimensions

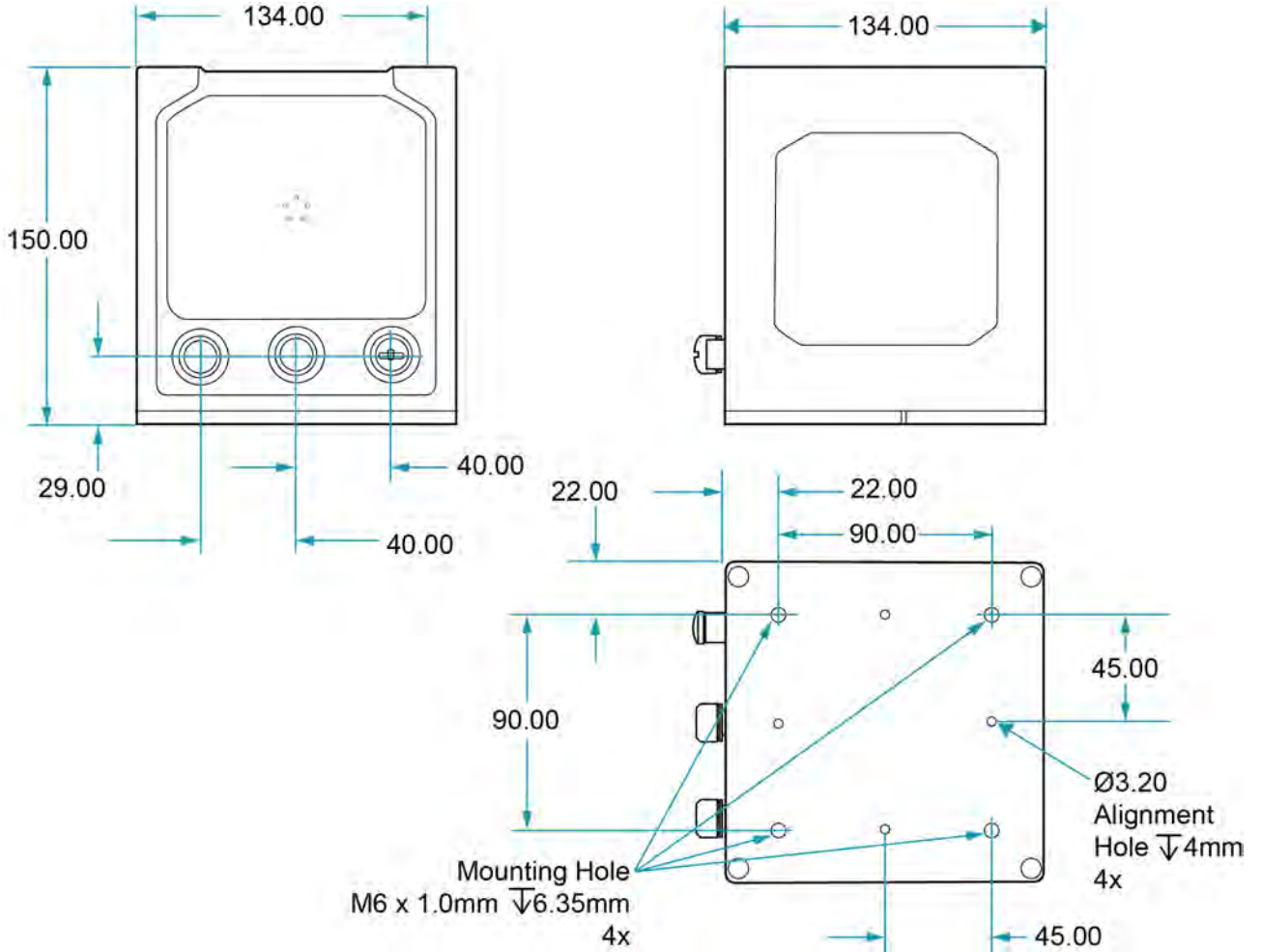
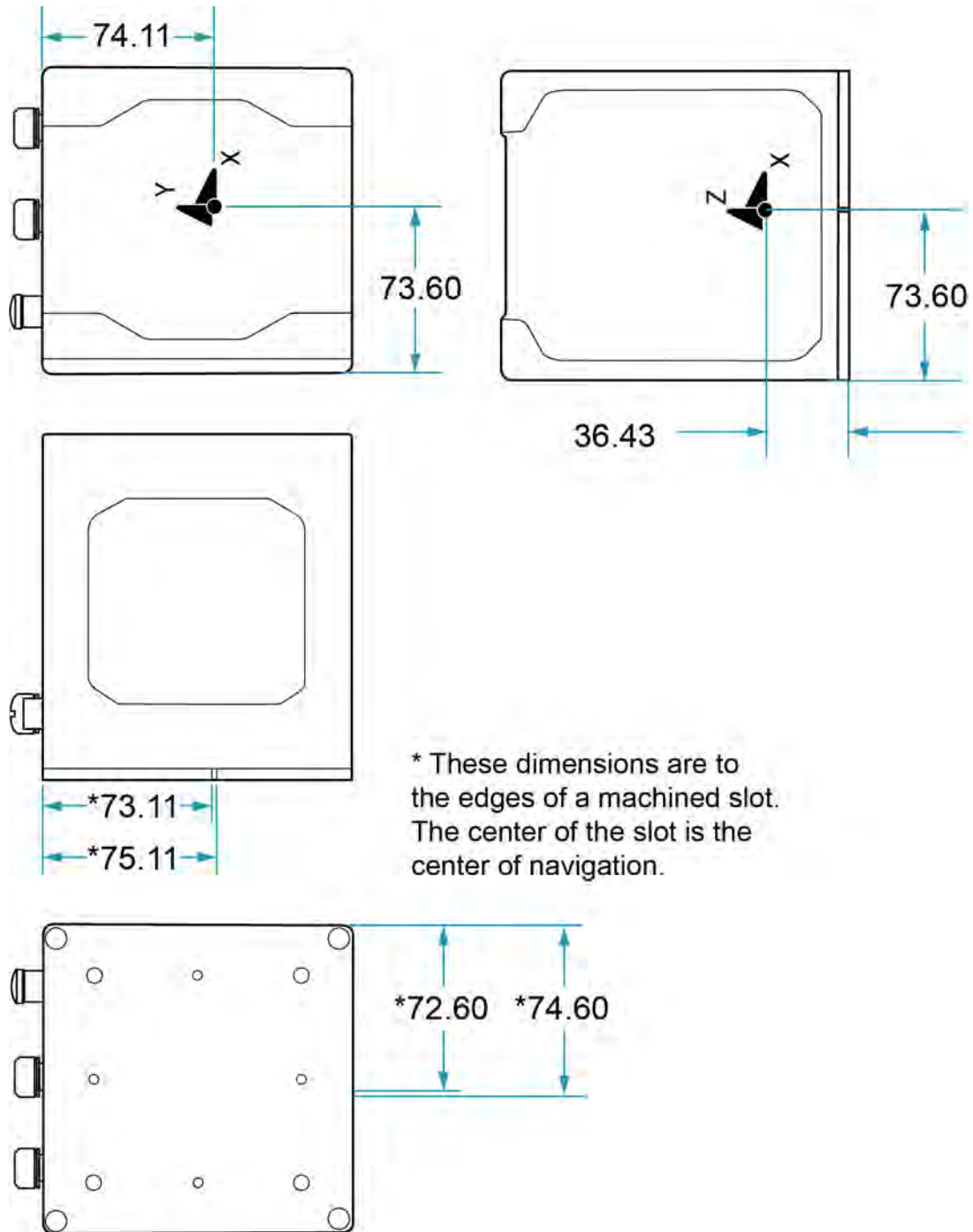

Figure 76: IMU-LN200 centre of navigation



A.11.2 IMU-LN200 sensor specifications**Table 108: LN-200 IMU performance**

Gyroscope performance	
Technology	FOG
Dynamic range	1420 °/s
Bias repeatability	1.0 °/hr
Angular random walk	0.07 °/√hr
Accelerometer performance	
Technology	MEMS
Dynamic range	40 g
Bias repeatability	0.3 mg
Data rate	
IMU measurement	200 Hz

Table 109: IMU-LN200C IMU performance

Gyroscope performance	
Technology	FOG
Dynamic range	490 °/s
Bias repeatability	1.0 °/hr
Angular random walk	0.07 °/√hr
Accelerometer performance	
Technology	MEMS
Dynamic range	15 g
Bias repeatability	0.3 mg
Data rate	
IMU measurement	200 Hz

A.11.3 IMU-LN200 electrical and environmental

Table 110: IMU-LN200 electrical specifications

Electrical	
IMU power consumption	17 W (typical)
IMU input voltage	+10 to +34 VDC
Recommended fuse	2.5 A slow blow
IMU interface	RS-422
Connectors	
Power	SAL M12, 5 pin, male
Data	SAL M12, 5 pin, female
Wheel Sensor	SAL M12, 8 pin, male

Table 111: IMU-LN200 environmental specifications

Environmental	
Operating temperature	-40°C to +55°C
Storage temperature	-40°C to +80°C
Humidity	MIL-STD-810G(Ch1), Method 507.6
Random vibrate	MIL-STD-810G(Ch1), Method 514.7 (2.0 g)
Environment	MIL-STD-810G(Ch1), Method 512.6 IEC 60529 IP67

A.11.4 IMU-LN200 cables

IMU-LN200 interface cable

The IMU-LN200 uses the IMU Enclosure Interface Cable. Refer to *IMU Enclosure interface cable* on page 199 for details about this cable.

IMU-LN200 power cable

The IMU-LN200 uses the IMU Enclosure Power Cable. Refer to *IMU Enclosure power cable* on page 201 for details about this cable.

IMU-LN200 wheel sensor cable

The IMU-LN200 uses the IMU Enclosure Wheel Sensor Cable. Refer to *IMU Enclosure wheel sensor cable* on page 202 for details about this cable.

A.12 IMU- μ IMU-IC

The IMU- μ IMU-IC contains a Litef μ IMU.

Table 112: IMU- μ IMU-IC physical specifications

Physical	
IMU enclosure size	130 mm x 130 mm x 115 mm
IMU enclosure weight	2.57 kg

See the following sections for more information about the IMU- μ IMU-IC.

- *IMU- μ IMU-IC mechanical drawings* on the next page
- *IMU- μ IMU-IC sensor specifications* on page 230
- *IMU- μ IMU-IC electrical and environmental* on page 231
- *IMU- μ IMU-IC cables* on page 231

A.12.1 IMU- μ IMU-IC mechanical drawings



In the following diagrams, the dimensions are in millimetres.

Figure 77: IMU- μ IMU-IC dimensions

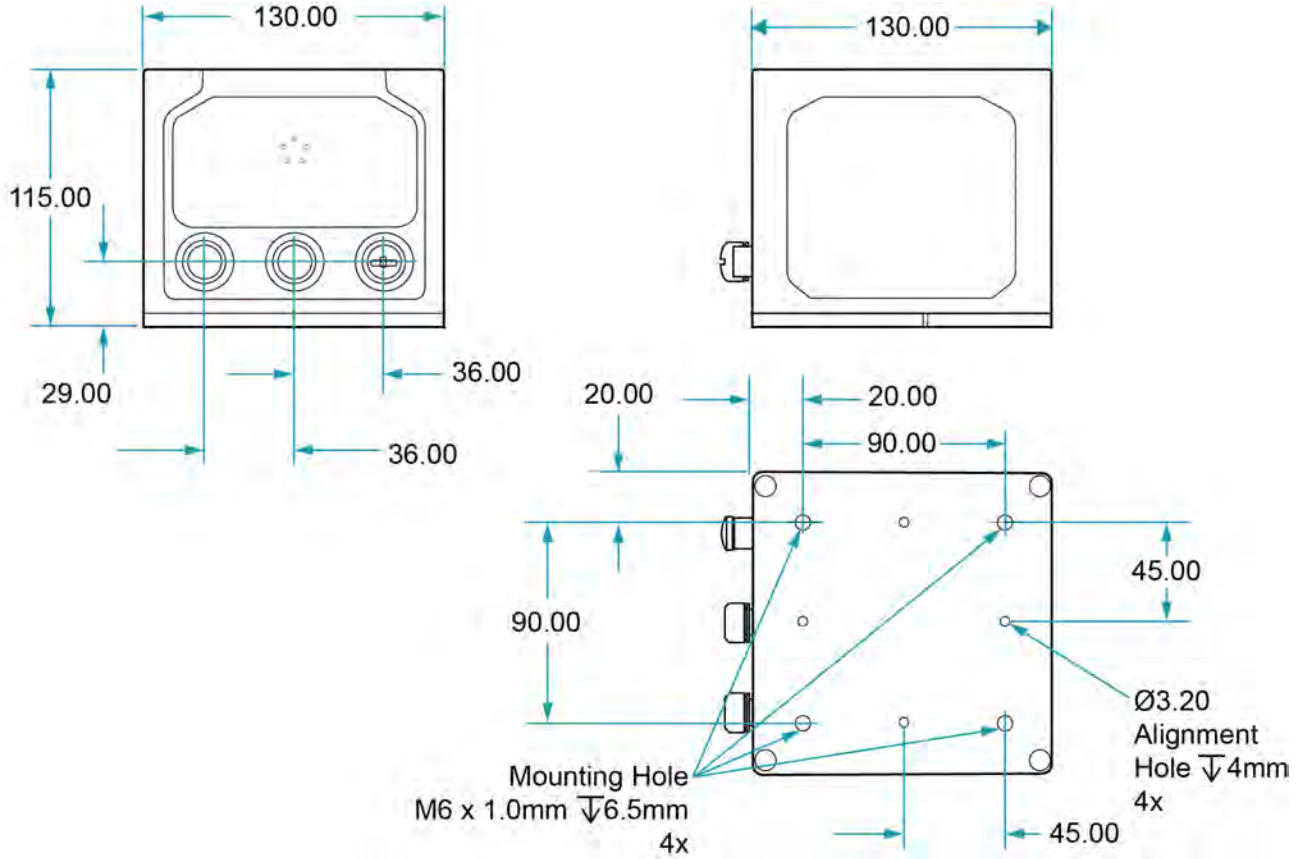
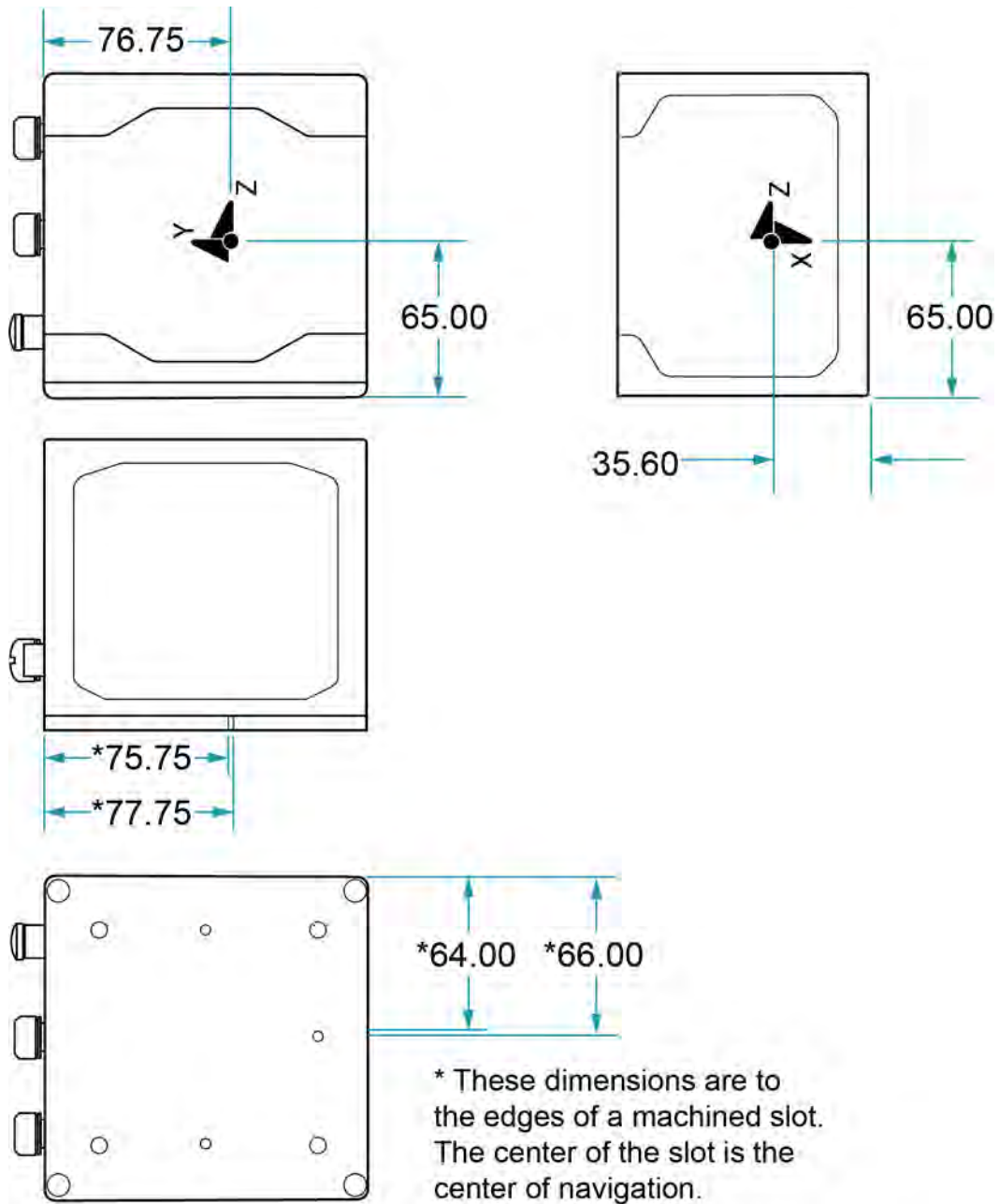

Figure 78: IMU- μ IMU-IC centre of navigation



A.12.2 IMU- μ IMU-IC sensor specifications

Table 113: IMU- μ IMU-IC IMU performance

Gyroscope performance	
Technology	MEMS
Dynamic range	499 °/s
Bias instability ¹	6 °/hr
Angular random walk ¹	0.12 °/ $\sqrt{\text{hr}}$
Accelerometer performance	
Technology	MEMS
Dynamic range	15 g
Bias instability ¹	3 mg
Velocity random walk ¹	0.150 m/s/ $\sqrt{\text{hr}}$
Data rate	
IMU measurement	200 Hz

1. Maximum value over temperature and lifetime estimations.

A.12.3 IMU- μ IMU-IC electrical and environmental

Table 114: IMU- μ IMU-IC electrical specifications

Electrical	
IMU power consumption	11 W (typical)
IMU input voltage	+10 to +34 VDC
Recommended fuse	1.8 A slow blow
IMU interface	RS-422
Connectors	
Power	SAL M12, 5 pin, male
Data	SAL M12, 5 pin, female
Wheel Sensor	SAL M12, 8 pin, male

Table 115: IMU- μ IMU-IC environmental specifications

Environmental	
Operating temperature	-40°C to +55°C
Storage temperature	-40°C to +71°C
Humidity	MIL-STD-810G(Ch1), Method 507.6
Random vibrate	MIL-STD-810G(Ch1), Method 514.7 (2.0 g)
Environment	MIL-STD-810G(Ch1), Method 512.6 IEC 60529 IP67

A.12.4 IMU- μ IMU-IC cables

IMU- μ IMU-IC interface cable

The IMU- μ IMU-IC uses the IMU Enclosure Interface Cable. Refer to *IMU Enclosure interface cable* on page 199 for details about this cable.

IMU- μ IMU-IC power cable

The IMU- μ IMU-IC uses the IMU Enclosure Power Cable. Refer to *IMU Enclosure power cable* on page 201 for details about this cable.

IMU- μ IMU-IC wheel sensor cable

The IMU- μ IMU-IC uses the IMU Enclosure Wheel Sensor Cable. Refer to *IMU Enclosure wheel sensor cable* on page 202 for details about this cable.

A.13 OEM-IMU-ADIS-16488



The OEM-IMU-ADIS-16488 requires a MEMS Interface Card (MIC) to connect to an OEM719 or OEM729 receiver. See *MIC – MEMS Interface Card* on page 277.

To connect the OEM-IMU-ADIS-16488 to an OEM7600, OEM7700 or OEM7720 receiver, you can use either a MIC or a direct connection via the SPI port.

Table 116: OEM-IMU-ADIS-16488 physical specifications

Physical	
IMU size	47 mm x 44 mm x 14 mm
IMU weight	48 g
IMU with mounting PCB size	71.1 mm x 45.7 mm x 17.6 mm

See the following sections for more information about the OEM-IMU-ADIS-16488.

- *OEM-IMU-ADIS-16488 mechanical drawings* on the next page
- *OEM-IMU-ADIS-16488 sensor specifications* on page 236
- *OEM-IMU-ADIS-16488 electrical and environmental* on page 236
- *OEM-IMU-ADIS-16488 SPI connection* on page 237
- *OEM-IMU-ADIS-16488 IMU-to-MIC cable assembly* on page 238

A.13.1 OEM-IMU-ADIS-16488 mechanical drawings

The following two drawings include the OEM-IMU-ADIS-16488 interface board. The OEM-IMU-ADIS-16488 with interface board is intended for use with a MIC.



In the following diagrams, the dimensions are in millimetres.

Figure 79: OEM-IMU-ADIS-16488 dimensions – with interface board

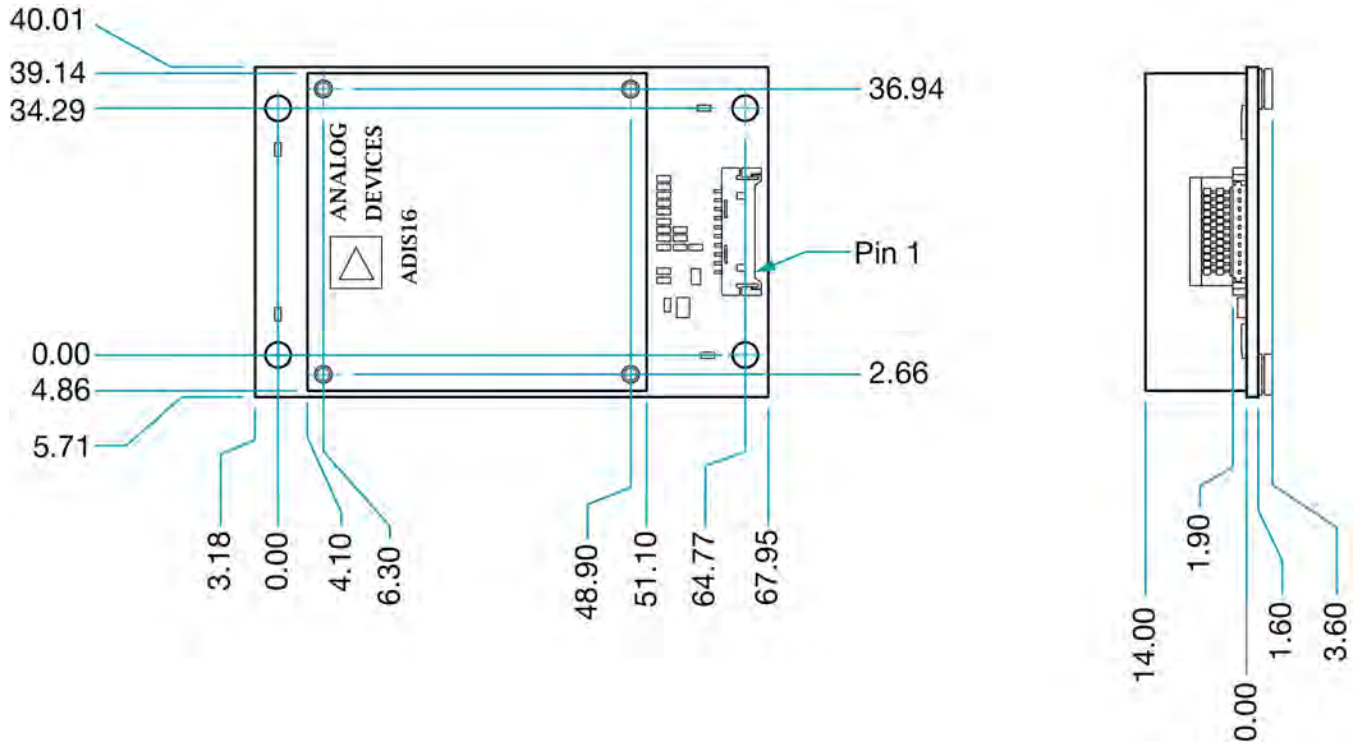
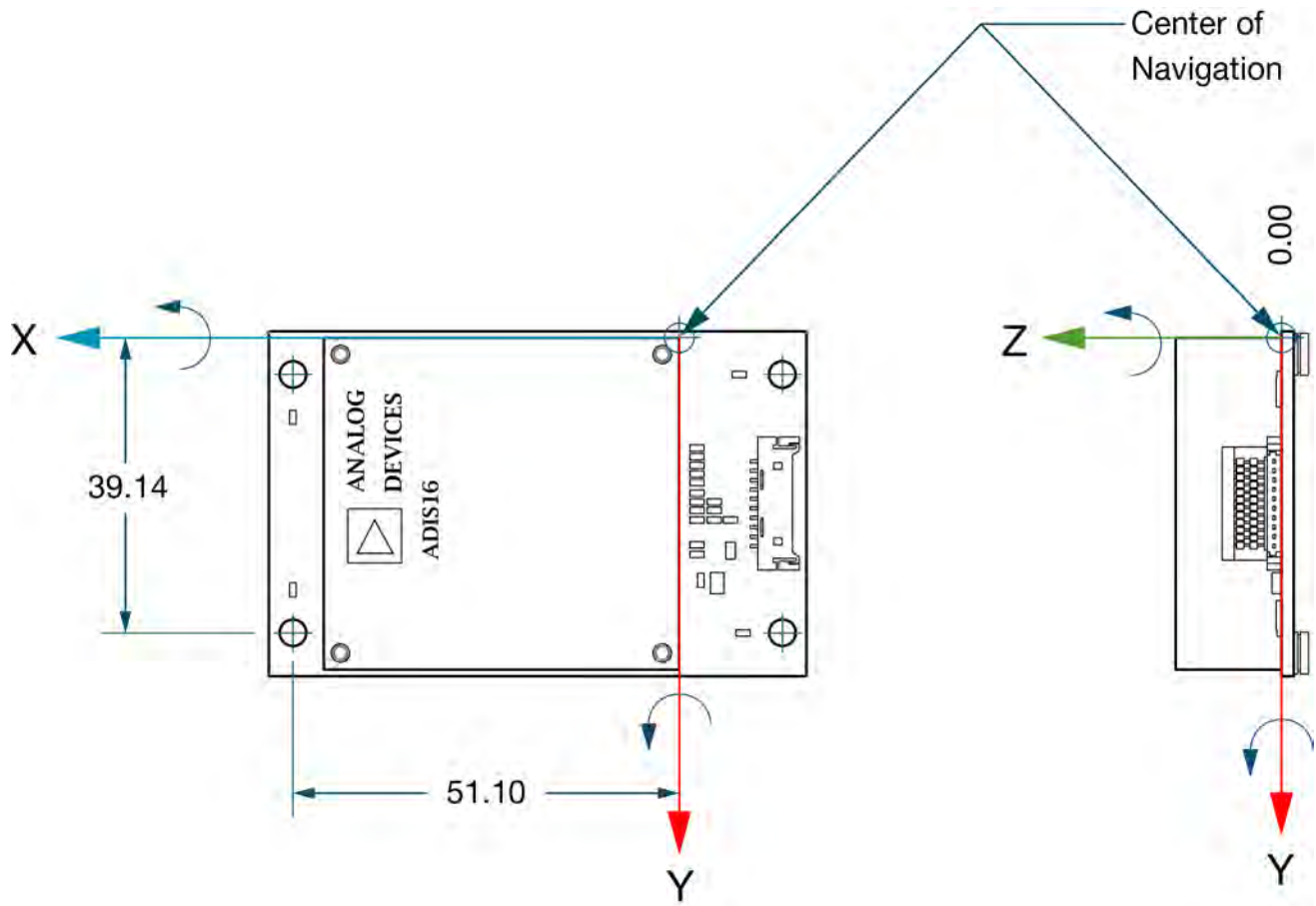
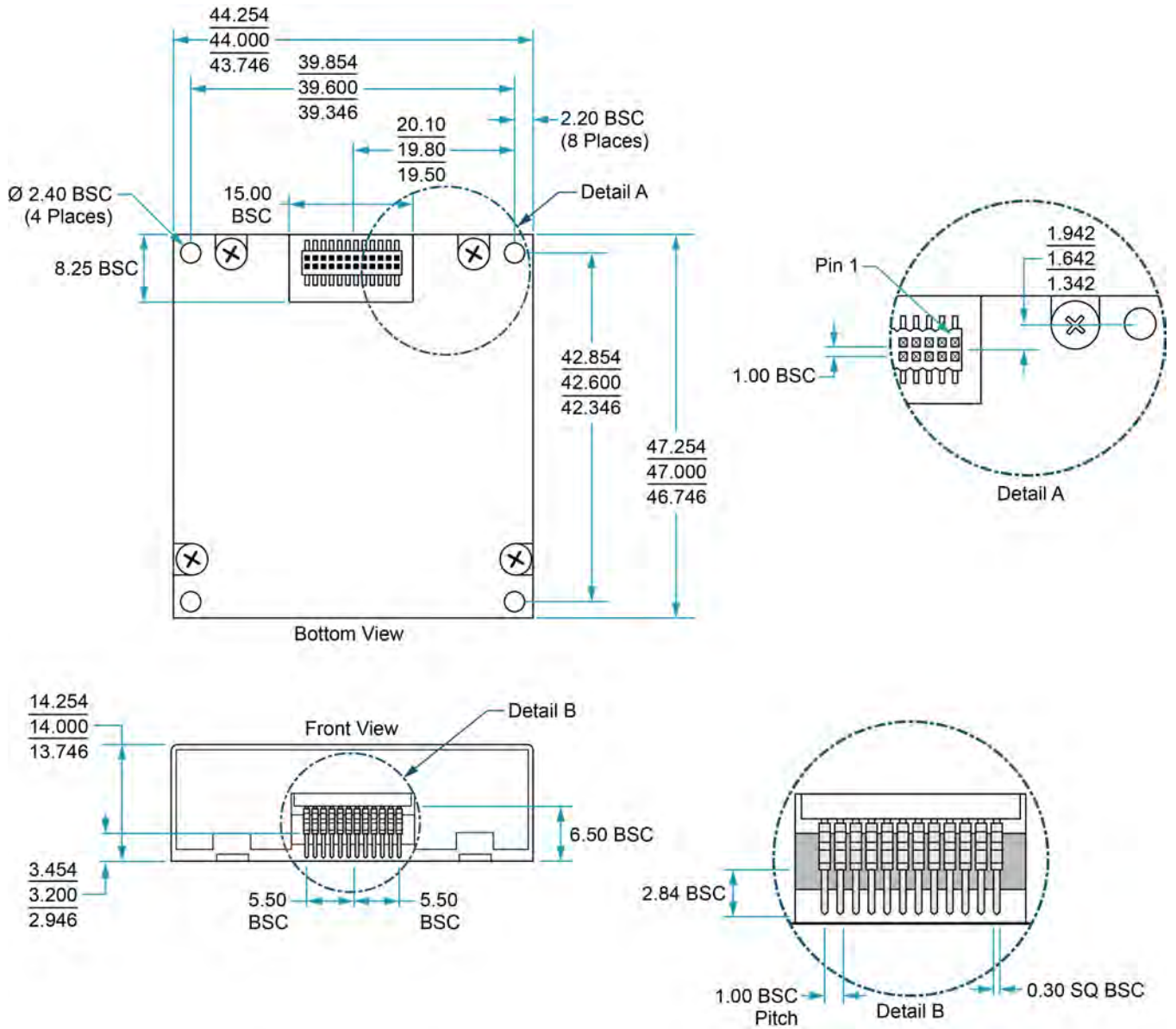

Figure 80: OEM-IMU-ADIS-16488 centre of navigation



The following diagram shows the OEM-IMU-ADIS-16488 without the interface board. The OEM-IMU-ADIS-16488 without interface board is for applications where the IMU connects directly to the OEM7 receiver using a SPI port.

Figure 81: OEM-IMU-ADIS-16488 dimensions



A.13.2 OEM-IMU-ADIS-16488 sensor specifications

Table 117: OEM-IMU-ADIS-16488 performance

Gyroscope performance	
Gyro input range	± 450 °/s
In-run gyro rate bias stability	6.25 °/hr
Angular random walk	0.30 °/ $\sqrt{\text{hr}}$
Accelerometer performance	
Accelerometer range	± 18 g
In-run accelerometer bias stability	0.1 mg
Velocity random walk	0.029 m/s/ $\sqrt{\text{hr}}$
Data rate	
IMU measurement	200 Hz

A.13.3 OEM-IMU-ADIS-16488 electrical and environmental

Table 118: OEM-IMU-ADIS-16488 electrical specifications

Electrical	
Input power	+3.0 to + 3.6 VDC +3.3 VDC typical
Power consumption	254 mA typical
Recommended fuse	0.5 A slow blow
IMU interface	SPI

Table 119: OEM-IMU-ADIS-16488 environmental specifications

Environmental	
Temperature, operational	-40°C to +85°C
Temperature, non-operational	-40°C to +105°C

A.13.4 OEM-IMU-ADIS-16488 SPI connection

The following table shows the connections required when connecting the OEM-IMU-ADIS-16488 IMU to a SPI compatible OEM7 receiver, such as the OEM7600, OEM7700 or OEM7720.



Pins not shown on the following table are not connected.

Table 120: Receiver to OEM-IMU-ADIS-16488 pin connections

ADIS-16488		Receiver		Description
Pin	Pin name	Pin	Pin name	
3	SCLK	44	SPI_SCLK	SPI Serial Clock
4	SDO	43	SPI_MISO	SPI Data Output
5	SDI	41	SPI_MOSI	SPI Data Input
6	\overline{CS}	42	SPI_nCS	SPI Chip Select
7	DIO1	26	EVENT_OUT2	Synchronization signal
8	\overline{RST}	–	–	<p>Reset IMU</p> <p>RST must be high for the IMU to be active.</p> <p>To enable the IMU when the receiver is powered on, connect this pin to Pin 1 or Pin 2 of the receiver interface connector through a 10 kΩ resistor (recommended).</p> <p>Can also connect this pin to any stable 3.3 VDC power supply or output configuration to have more control over when IMU is enabled. When using this configuration note that:</p> <ul style="list-style-type: none"> pin 8 must be pulled low for greater than 100 ms to properly soft-reset the IMU pin has an internal pull-up resistor
9	DIO2	29	EVENT_IN2	Data ready
10-12	VDD	–	–	3.3 VDC power supply
13-15	GND	–	–	Digital ground



In the table above, the receiver pin numbers are for OEM7600, OEM7700 and OEM7720 receivers. For the location of the receiver card pins, refer to the [OEM7 Installation and Operation User Manual](#).

For more information about connecting using a SPI port, refer to *Connect an OEM-IMU-ADIS-16488 directly to an OEM7 receiver card* on page 41.

A.13.5 OEM-IMU-ADIS-16488 IMU-to-MIC cable assembly

The NovAtel part number for the OEM-IMU-ADIS-16488 IMU-to-MIC interface cable is 01019008 (*Figure 82: OEM-IMU-ADIS-16488 IMU-to-MIC cable assembly* below). This cable provides power to the IMU and enables communication between the MIC and the IMU.

Figure 82: OEM-IMU-ADIS-16488 IMU-to-MIC cable assembly

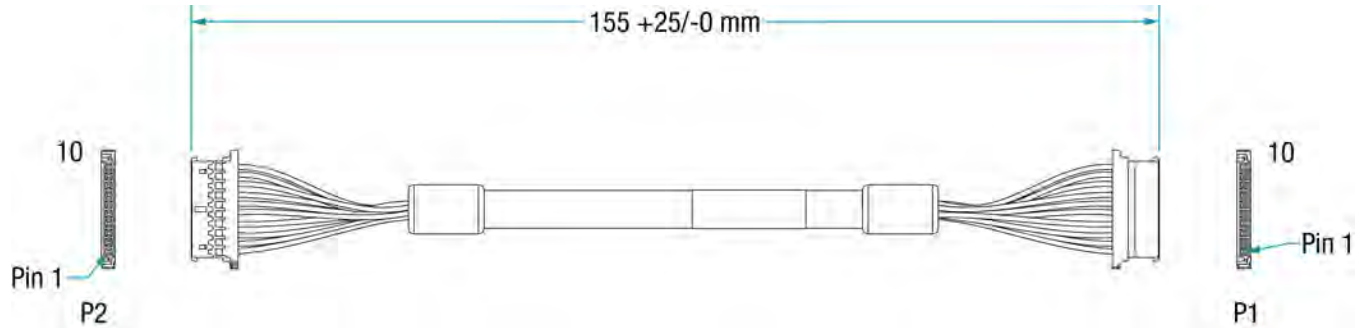

Table 121: OEM-IMU-ADIS-16488 IMU-to-MIC cable pinout

P2 pin	Signal name	P1 pin
1	IMU_VDD	1
2	IMU_VDD	2
3	SPI_NSS	3
4	SPI_CLK	4
5	Ground	5
6	SPI_MOSI	6
7	SPI_MISO	7
8	Ground	8
9	ADIS_IMU_DIO1	9
10	ADIS_IMU_DIO2	10

A.14 OEM-IMU-EG320N

Table 122: OEM-IMU-EG320N physical specifications

Physical	
IMU size	24 mm x 24 mm x 10 mm
IMU weight	10 g

See the following sections for more information about the OEM-IMU-EG320N IMU.

- *OEM-IMU-EG320N mechanical drawings* on the next page
- *OEM-IMU-EG320N sensor specifications* on page 241
- *OEM-IMU-EG320N electrical and environmental* on page 242
- *OEM-IMU-EG320N interface connector* on page 243

A.14.1 OEM-IMU-EG320N mechanical drawings



The following graphics are courtesy of Seiko Epson Corporation.



In the following diagram, the dimensions are in millimetres.

Figure 83: EG320N dimensions

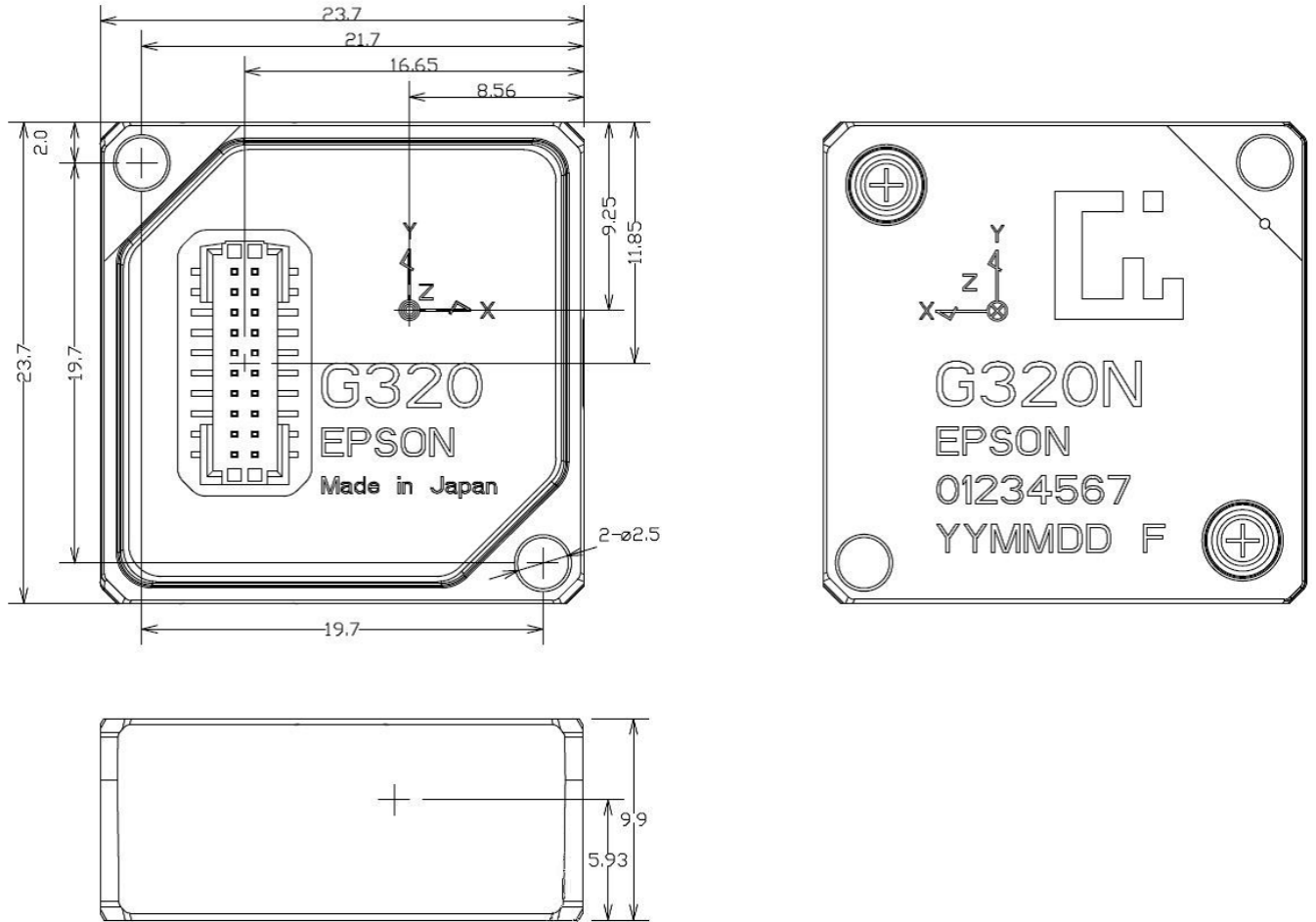

A.14.2 OEM-IMU-EG320N sensor specifications



IMU specifications are provided by the Seiko Epson Corporation. For more information about the IMU specifications, refer to the Epson website.



Peak vibration amplitude in the frequency range of 700 Hz to 900 Hz must be minimized to achieve optimal SPAN performance.

Table 123: OEM-IMU-EG320N performance

Gyroscope performance	
Technology	MEMS
Dynamic range	150 °/s
Bias instability	3.5 °/hr
Angular random walk	0.1 °/√hr
Accelerometer performance	
Technology	MEMS
Dynamic range	5 g
Bias instability	0.1 mg
Velocity random walk	0.05 m/s/√hr
Data rate	
IMU measurement	125 Hz 200 Hz

A.14.3 OEM-IMU-EG320N electrical and environmental**Table 124: OEM-IMU-EG320N electrical specifications**

Electrical	
Input power	+3.15 to +3.45 VDC +3.3 VDC typical
Power consumption	0.1 W nominal
Recommended fuse	0.25 A slow blow

Table 125: OEM-IMU-EG320N environmental specifications

Environmental	
Temperature, operational	-40°C to +85°C
Temperature, storage	-40°C to +85°C
Vibration, operating	MIL-STD-810G, 7.7 g RMS, 20 - 2000 Hz
Shock, operating	MIL-STD-810G, 40 g, 11 ms
Shock, survival	1000 g, half sine, 0.5 ms

A.14.4 OEM-IMU-EG320N interface connector



This graphic is courtesy of Seiko Epson Corporation.

Figure 84: OEM-IMU-EG320N pin locations

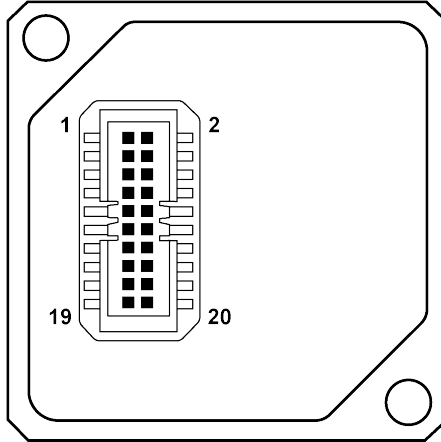

Table 126: OEM-IMU-EG320N connector

Pin	Pin name	Description
1	SCLK	SPI Serial Clock
2	SDO	SPI Data Output
3	GND	Digital ground
4	GND	Digital ground
5	SDI	SPI Data Input
6	\overline{CS}	SPI Chip Select
7*	SOUT	UART Data Out
8	GND	Digital ground
9*	SIN	UART Data In
10	VCC	3.3 VDC power supply
11	VCC	3.3 VDC power supply
12	VCC	3.3 VDC power supply
13	DRDY(GPIO1)	Data Ready
14	GPIO2(EXT)	External Trigger
15	GND	Digital ground

Pin	Pin name	Description
16	$\overline{\text{RST}}$	Reset IMU RST must be high for the IMU to be active.
17	NC	Do not connect
18	NC	Do not connect
19	NC	Do not connect
20	NC	Do not connect



The OEM-IMU-EG320N requires a Samtec CLM-110-02-H-D mating connector.

A.15 OEM-IMU-EG370N

Table 127: OEM-IMU-EG370N physical specifications

Physical	
IMU size	24 mm x 24 mm x 10 mm
IMU weight	10 g

See the following sections for more information about the OEM-IMU-EG370N IMU.

- *OEM-IMU-EG370N mechanical drawings* on the next page
- *OEM-IMU-EG370N sensor specifications* on page 247
- *OEM-IMU-EG370N electrical and environmental* on page 247
- *OEM-IMU-EG370N interface connector* on page 248

A.15.1 OEM-IMU-EG370N mechanical drawings



The following graphics are courtesy of Seiko Epson Corporation.



In the following diagram, the dimensions are in millimetres.

Figure 85: EG370N dimensions

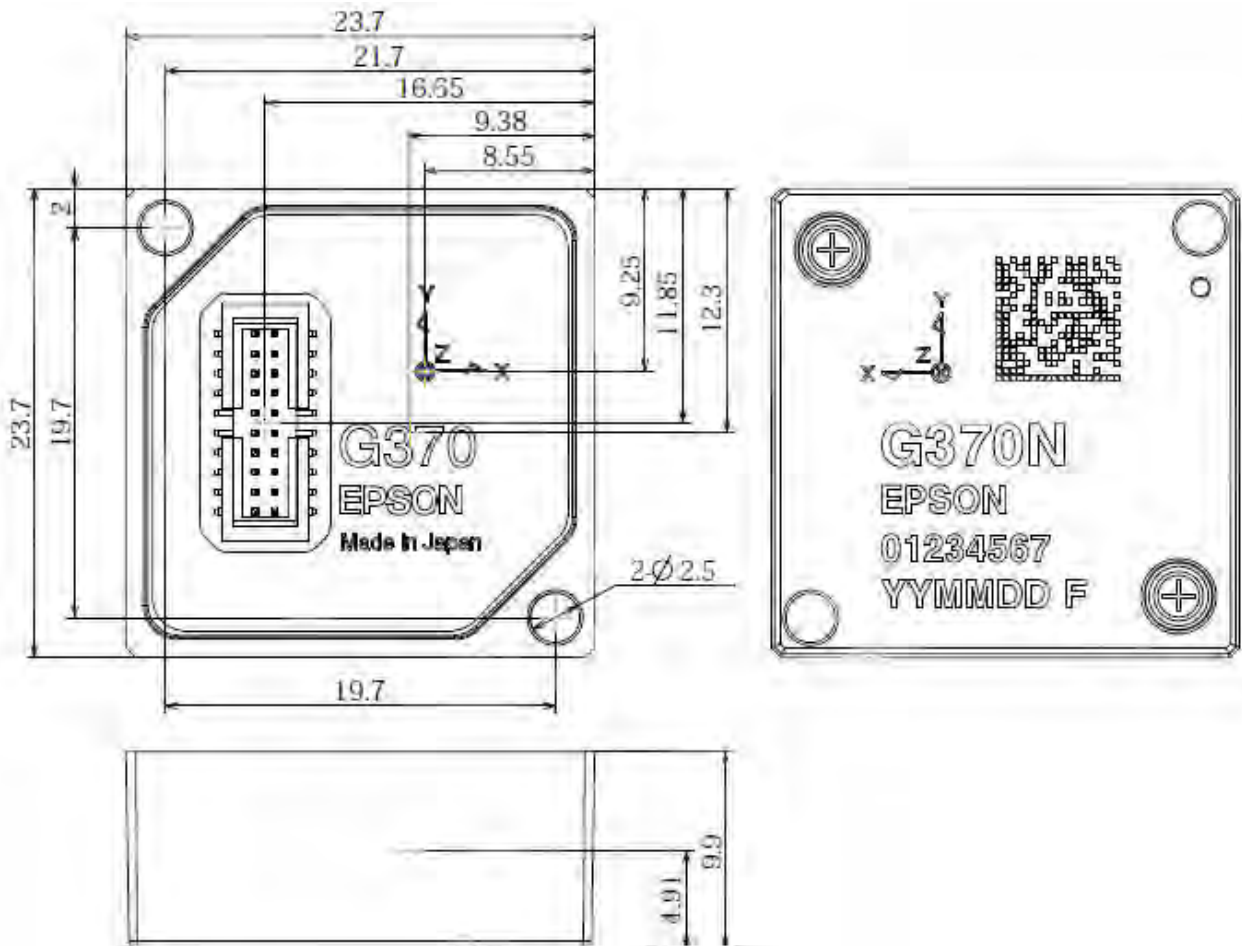

A.15.2 OEM-IMU-EG370N sensor specifications



IMU specifications are provided by the Seiko Epson Corporation. For more information about the IMU specifications, refer to the Epson website.

Table 128: OEM-IMU-EG370N performance

Gyroscope performance	
Technology	MEMS
Dynamic range	450 °/s
Bias instability	0.8 °/hr
Angular random walk	0.06 °/√hr
Accelerometer performance	
Technology	MEMS
Dynamic range	10 g
Bias instability	0.012 mg
Velocity random walk	0.025 m/s/√hr
Data rate	
IMU measurement	200 Hz

A.15.3 OEM-IMU-EG370N electrical and environmental

Table 129: OEM-IMU-EG370N electrical specifications

Electrical	
Input power	+3.15 to +3.45 VDC +3.3 VDC typical
Power consumption	0.1 W nominal
Recommended fuse	0.25 A slow blow

Table 130: OEM-IMU-EG370N environmental specifications

Environmental	
Temperature, operational	-40°C to +85°C
Temperature, non-operational	-40°C to +85°C
Vibration, operating	MIL-STD-810G, 7.7 g RMS, 20 - 2000 Hz
Shock, operating	MIL-STD-810G, 40 g, 11 ms
Shock, survival	1000 g, half sine, 0.5 ms

A.15.4 OEM-IMU-EG370N interface connector



This graphic is courtesy of Seiko Epson Corporation.

Figure 86: OEM-IMU-EG370N pin locations

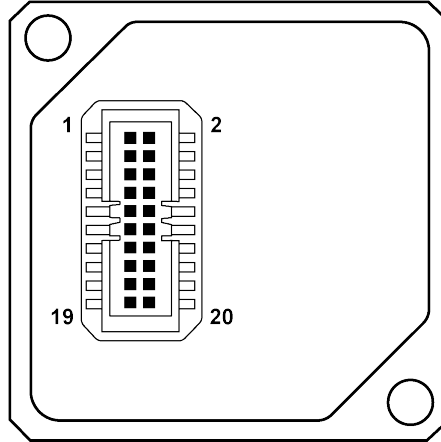

Table 131: OEM-IMU-EG370N connector

Pin	Pin name	Description
1	SCLK	SPI Serial Clock
2	SDO	SPI Data Output
3	GND	Digital ground
4	GND	Digital ground
5	SDI	SPI Data Input
6	\overline{CS}	SPI Chip Select
7*	SOUT	UART Data Out
8	GND	Digital ground
9*	SIN	UART Data In
10	VCC	3.3 VDC power supply
11	VCC	3.3 VDC power supply
12	VCC	3.3 VDC power supply
13	DRDY(GPIO1)	Data Ready
14	GPIO2(EXT)	External Trigger
15	GND	Digital ground

Pin	Pin name	Description
16	$\overline{\text{RST}}$	Reset IMU RST must be high for the IMU to be active.
17	NC	Do not connect
18	NC	Do not connect
19	NC	Do not connect
20	NC	Do not connect



The OEM-IMU-EG370N requires a Samtec CLM-110-02-H-D mating connector.

A.16 OEM-IMU-HG4930

Table 132: OEM-IMU-HG4930 physical specifications

Physical	
IMU size	64.8 mm diameter × 35.7 mm height
IMU weight	200 g

See the following sections for information about the OEM-IMU-HG4930 IMU.

- *OEM-IMU-HG4930 mechanical drawings* on the next page
- *OEM-IMU-HG4930 sensor specifications* on page 252
- *OEM-IMU-HG4930 electrical and environmental* on page 252
- *OEM-IMU-HG4930 interface connector* on page 253

A.16.1 OEM-IMU-HG4930 mechanical drawings

Figure 87: OEM-IMU-HG4930 centre of navigation

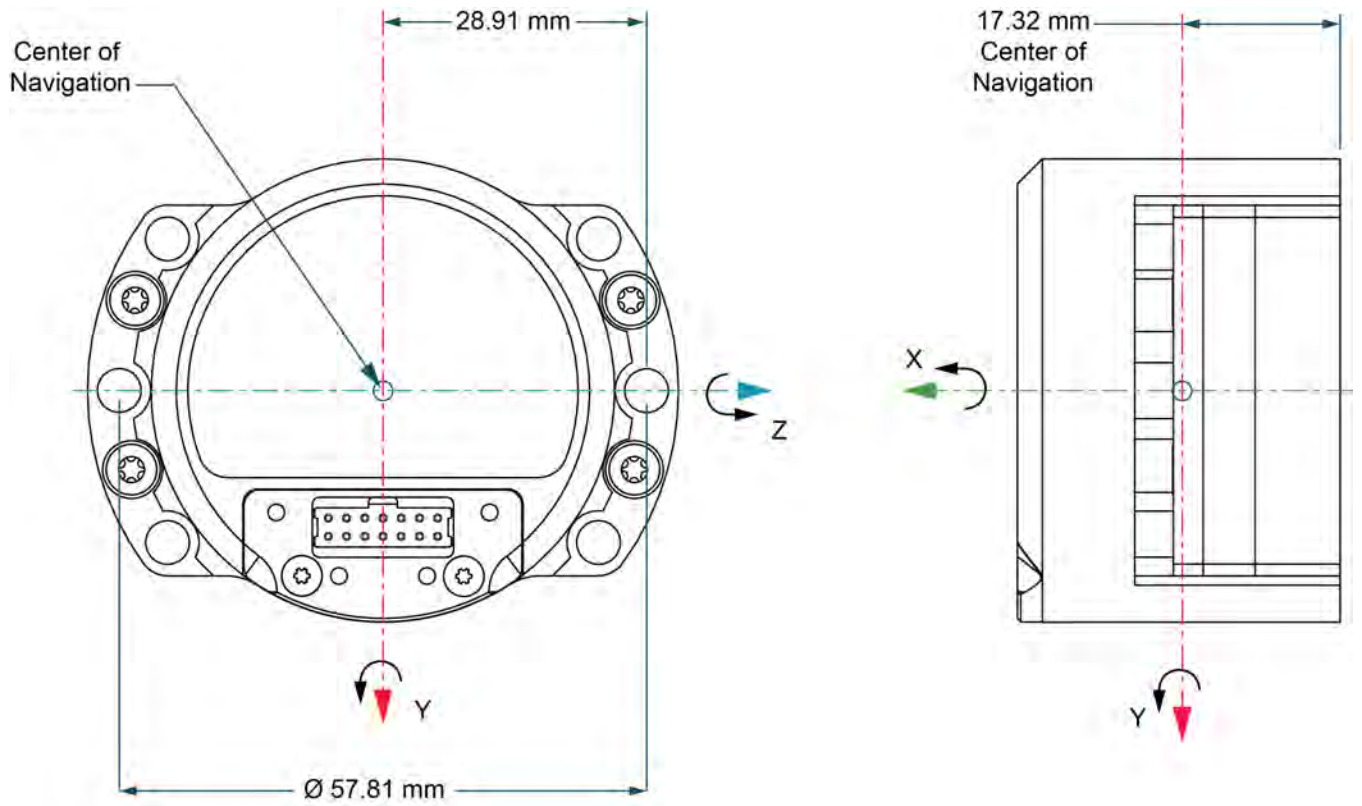

For additional mechanical drawings, visit the Honeywell Aerospace website (aerospace.honeywell.com).

A.16.2 OEM-IMU-HG4930 sensor specifications

Table 133: OEM-IMU-HG4930 performance

Gyroscope performance	
Technology	MEMS
Dynamic range ¹	400 °/s
Bias instability	0.45 °/hr
Angular random walk	0.06 °/√hr
Accelerometer performance	
Technology	MEMS
Dynamic range	20 g
Bias instability	0.075 mg
Velocity random walk	0.06 m/s/√hr
Data rate	
IMU measurement – AN01	100 Hz
IMU measurement – AN04	100 Hz or 400 Hz

A.16.3 OEM-IMU-HG4930 electrical and environmental

Table 134: OEM-IMU-HG4930 electrical specifications

Electrical	
Input power	+5.0 VDC
Power consumption	<3 W typical
Recommended fuse	1.6 A slow blow
Connector	14 pin header

Table 135: OEM-IMU-HG4930 environmental specifications

Environmental	
Temperature, operational	-40°C to +71°C
Temperature, storage	-40°C to +80°C
Random vibration	MIL-STD-810G(Ch1), Method 514.7 (2.0g)

1. Performance specifications qualified to 325 °/s.

A.16.4 OEM-IMU-HG4930 interface connector

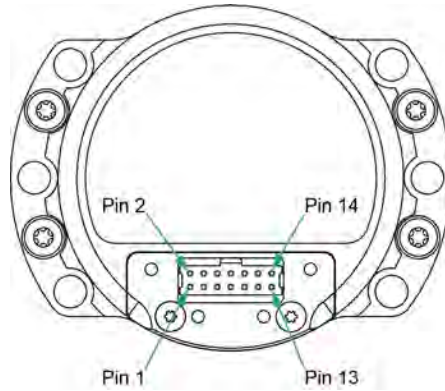

Table 136: OEM-IMU-HG4930 connector

Pin	Pin name	Description
1	GND	Ground
2	+5V	+5 VDC power supply input
3	TMI	Timing input
4	No connect	No connect
5	No connect	No connect
6	Reserved	Reserved
7	No connect	No connect
8	No connect	No connect
9	SER_DATA_OUT_H	Serial Data High Output (RS-485)
10	SER_DATA_OUT_L	Serial Data Low Output (RS-485)
11	TTL_TX	Transmit data (RS-232) Serial communication port
12	TTL_RX	Receive data (RS-232) Serial communication port
13	No connect	No connect
14	No connect	No connect

A.17 OEM-IMU-ISA-100C



The OEM-IMU-ISA-100C requires a Universal IMU Controller Card to connect to a NovAtel receiver. See *UIC – Universal IMU Controller* on page 290.

Table 137: OEM-IMU-ISA-100C physical specifications

Physical	
IMU size	100 mm x 130 mm x 125 mm
IMU weight	2 kg

See the following sections for more information about the OEM-IMU-ISA-100C IMU.

- *OEM-IMU-ISA-100C mechanical drawings* on the next page
- *OEM-IMU-ISA-100C sensor specifications* on page 258
- *OEM-IMU-ISA-100C electrical and environmental* on page 258
- *OEM-IMU-ISA-100C IMU to UIC cable assembly* on page 259

A.17.1 OEM-IMU-ISA-100C mechanical drawings



The following graphics are courtesy of Northrop Grumman LITEF GmbH.



In the following diagrams, the dimensions are in millimetres.

Figure 88: OEM-IMU-ISA-100C centre of gravity

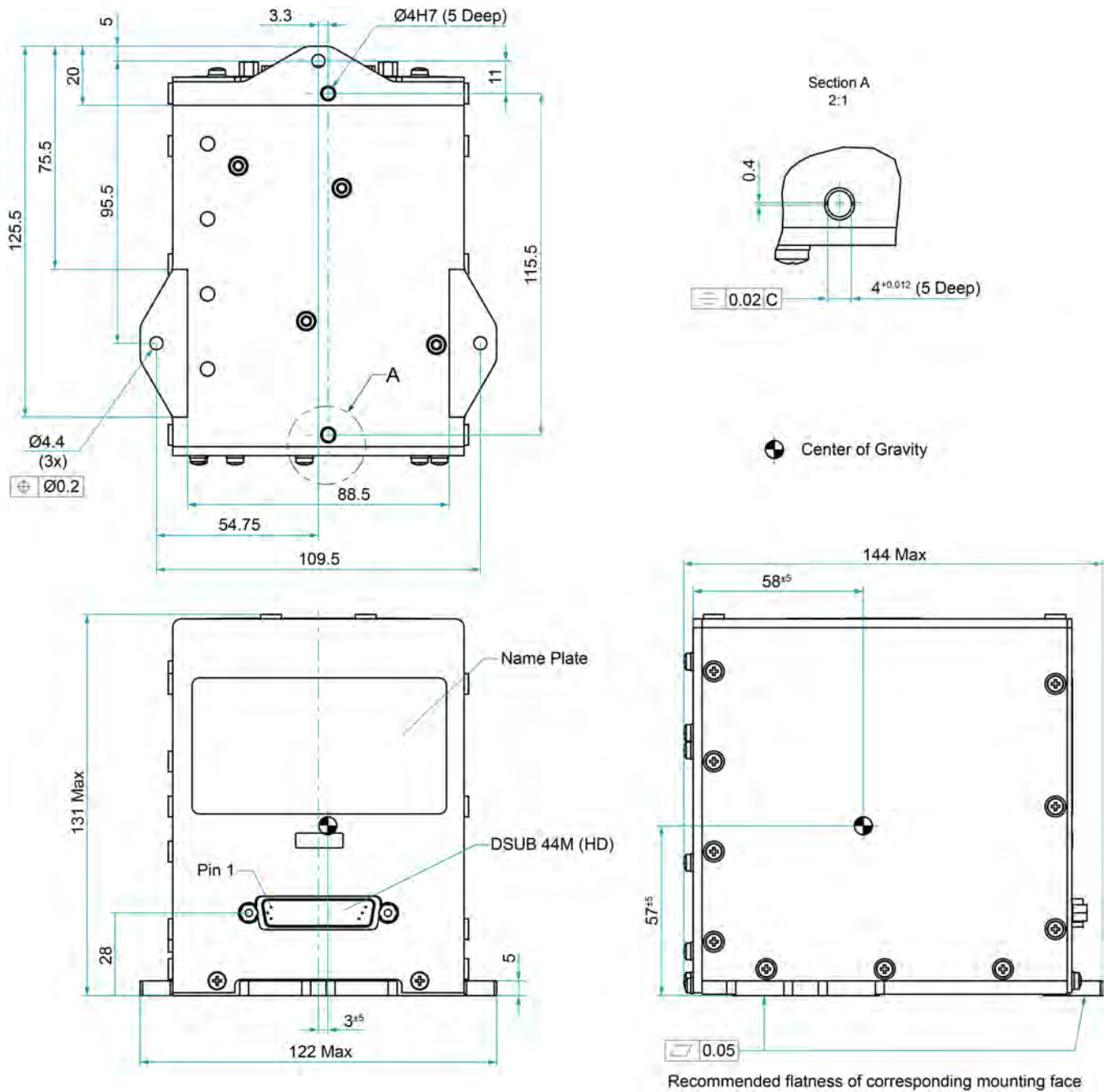
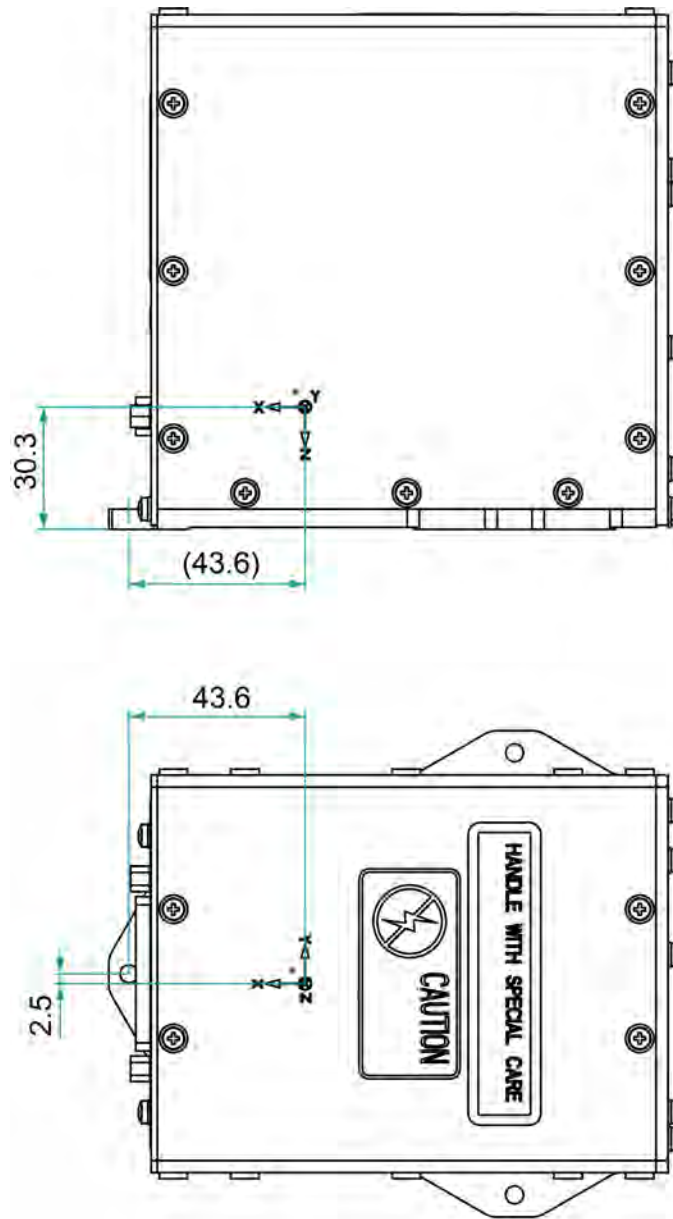
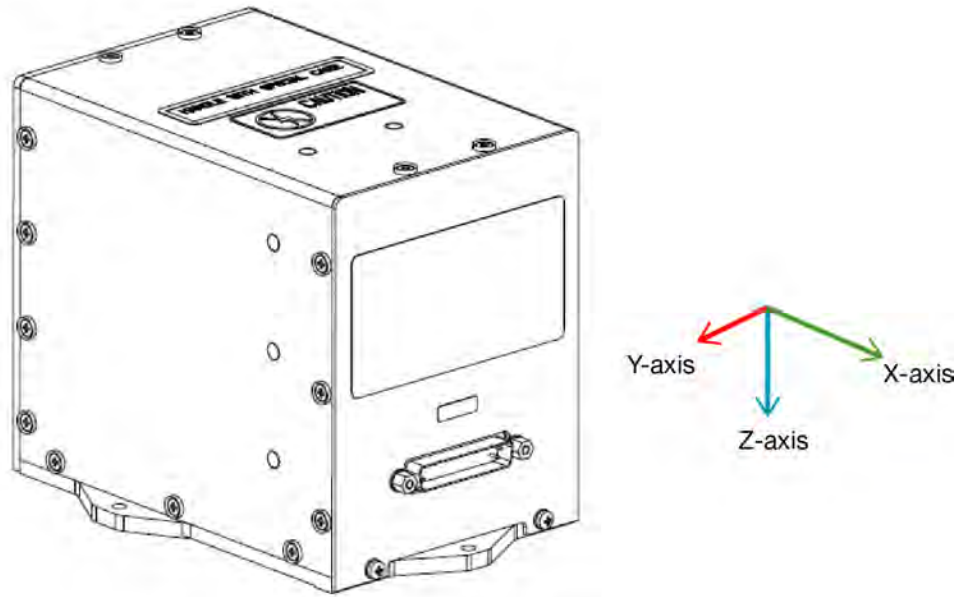

Figure 89: OEM-IMU-ISA-100C centre of accelerometers



* Dynamic Center of Accelerometers

Figure 90: OEM-IMU-ISA-100C coordinate axis



A.17.2 OEM-IMU-ISA-100C sensor specifications

Table 138: OEM-IMU-ISA-100C IMU performance

Gyroscope performance	
Technology	FOG
Dynamic range	495 °/s
Bias instability	0.05 °/hr
Angular random walk (typical)	0.005 °/√hr
Accelerometer performance	
Technology	MEMS
Dynamic range	10 g
Bias instability	0.1 mg
Velocity random walk (typical)	0.018 m/s/√hr
Data rate	
IMU measurement	200 Hz

A.17.3 OEM-IMU-ISA-100C electrical and environmental

Table 139: OEM-IMU-ISA-100C electrical specifications

Electrical	
Input power	+3.3 V, ±5.25 V, ±15 V, -15 V (optional)
Power consumption	≤10 W (typical) 16 W (maximum)
Recommended fuse	1.6 A slow blow
Connector	44 pin HD D-Sub, male

Table 140: OEM-IMU-ISA-100C environmental specifications

Environmental	
Temperature, operational	-40°C to +71°C

A.17.4 OEM-IMU-ISA-100C IMU to UIC cable assembly

The NovAtel part number for the OEM-IMU-ISA-100C IMU to UIC interface cable is 01019393 (*Figure 91: OEM-IMU-ISA-100C IMU to UIC cable assembly* below). This cable provides power to the IMU and enables communication between the UIC and the IMU.

Figure 91: OEM-IMU-ISA-100C IMU to UIC cable assembly

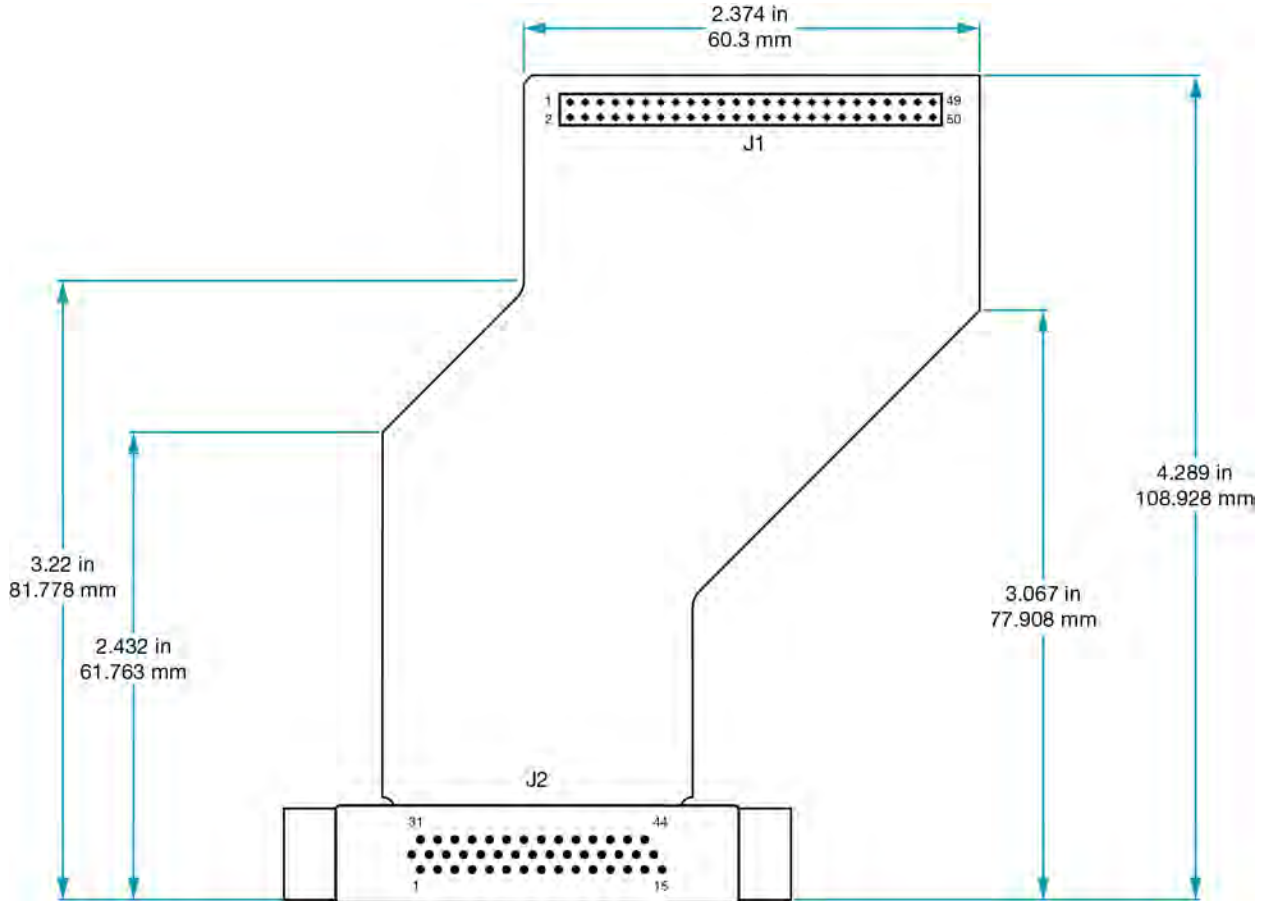

Table 141: OEM-IMU-ISA-100C IMU to UIC cable pinout

J2 pin (ISA-100C)	Signal	J1 pin (UIC)
1	GND	9
2	3.3 V	1
3	GND	4
4	GND	5
5	GND	6
6	GND	8
7	GND	10
8	GND	15

J2 pin (ISA-100C)	Signal	J1 pin (UIC)
9	GND	16
10	GND	21
11	GND	22
12	5.25 V	43
13	-5.25 V	49
14	-5.25 V	50
15	-5.25 V	
16	15 V	7
17	3.3 V	3
18	GND	28
19	–	–
20	–	–
21	NOGOx	18
22	–	–
23	GND	29
	GND	35
24	TXC+	32
25	SYNC-	34
26	GND	41
27	TXD+	40
28	–	–
29	GND	42
30	5.25 V	44
31	3.3 V	2
32	3.3 V	
33	PWRDOWNx	12
34	RESETIMUx	14
35	–	–
36	GND	45
37	–	–
38	TXC-	30

J2 pin (ISA-100C)	Signal	J1 pin (UIC)
39	GND	48
40	SYNC+	36
41	TXD-	38
42	–	–
43	GND	48
44	5.25 V	46

A.18 OEM-IMU-STIM300



The OEM-IMU-STIM300 can use a MEMS Interface Card (MIC) or a direct RS-422 link to connect to an OEM7 receiver.

For information about using a MIC, see *MIC – MEMS Interface Card* on page 277.

For information about using a direct RS-422 link, see *Connect an OEM-IMU-STIM300 directly to an OEM7 receiver* on page 45.

Table 142: OEM-IMU-STIM300 physical specifications

Physical	
IMU size	45 mm x 39 mm x 22 mm
IMU weight	55 g

See the following sections for more information about the OEM-IMU-STIM300 IMU.

- *OEM-IMU-STIM300 mechanical drawings* on the next page
- *OEM-IMU-STIM300 sensor specifications* on page 264
- *OEM-IMU-STIM300 electrical and environmental* on page 264
- *OEM-IMU-STIM300 direct connection* on page 265
- *OEM-IMU-STIM300 IMU-to-MIC cable assembly* on page 268

A.18.1 OEM-IMU-STIM300 mechanical drawings



The following graphics are courtesy of Sensoror AS.



In the following diagrams, the dimensions are in millimetres.

Figure 92: OEM-IMU-STIM300 dimensions

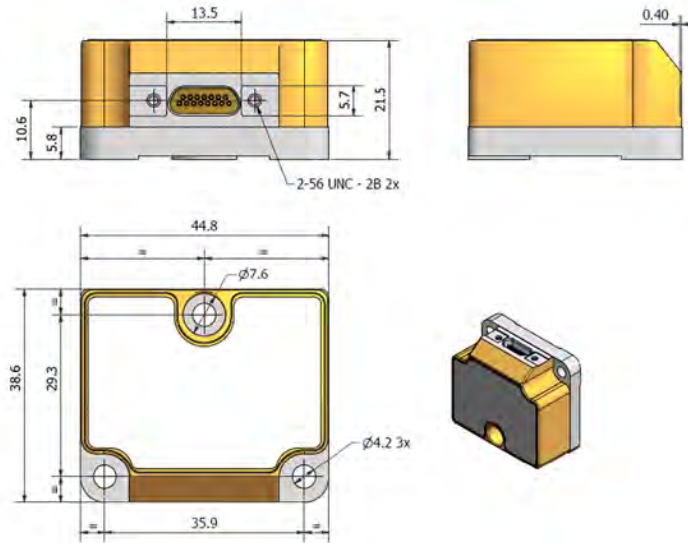
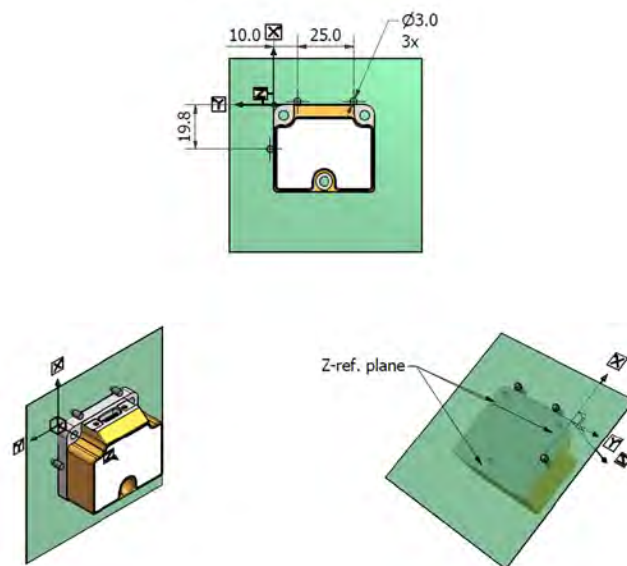

Figure 93: OEM-IMU-STIM300 centre of navigation



A.18.2 OEM-IMU-STIM300 sensor specifications



IMU specifications are provided by the Safran Sensing Technologies. For more information about the IMU specifications, refer to the Safran website.

Table 143: OEM-IMU-STIM300 performance

Gyroscope performance	
Technology	MEMS
Dynamic range	400 °/s
Bias instability	0.3 °/hr
Angular random walk	0.15 °/√hr
Accelerometer performance	
Technology	MEMS
Dynamic range	10 g
Bias instability	0.04 mg
Velocity random walk	0.07 m/s/√hr
Data rate	
IMU measurement	125 Hz

A.18.3 OEM-IMU-STIM300 electrical and environmental

Table 144: OEM-IMU-STIM300 electrical specifications

Electrical	
Input power	+4.5 to +5.5 VDC +5.0 VDC typical
Power consumption	1.5 W nominal
Recommended fuse	0.63 A slow blow
Connector	15 pin Micro-D, female

Table 145: OEM-IMU-STIM300 environmental specifications

Environmental	
Temperature, operational	-40°C to +85°C
Temperature, storage	-55°C to +90°C

A.18.4 OEM-IMU-STIM300 direct connection

The following table shows the connections required when connecting the OEM-IMU-STIM300 to an OEM7 receiver using a RS-422 link.



Pins not shown on the following tables are not connected.

Table 146: OEM7 receiver card to OEM-IMU-STIM300 pin connections



STIM300		RS-422 line driver		Receiver	
Pin	Pin name	Output	Input	Pin name	Description
1	STIM TxD-	RS422 B-	–	–	Part of RS-422 transmit pair from STIM300
2	STIM RxD-	RS422 A-	–	–	Part of RS-422 receive pair from STIM300
4	STIM TOV	–	–	EVENT_IN2 OEM719: 7 OEM729: 7 OEM7600 : 29 OEM7700: 29 OEM7720: 29	 Interface Circuit Required The STIM TOV output uses 5V logic, but the OEM7 EVENT_IN lines are not 5V tolerant. A circuit to convert from 5V logic to 3.3V levels is required.
8	5V Pwr	–	–	–	5 VDC power supply
9	STIM TxD+	RS422 B+	–	–	Part of RS-422 transmit pair from STIM300
10	STIM RxD+	RS422 A+	–	–	Part of RS-422 receive pair from STIM300
12	GND	–	–	–	Any receiver ground pin
13	GND	–	–	–	Any receiver ground pin
15	GND	–	–	–	Any receiver ground pin
–	–	–	LVC MOS A IN	COMx_TXD	Any receiver COM port transmit and receive pair
–	–	–	LVC MOS B IN	COMx_RXD	
–	–	–	GND	–	Any receiver ground pin

Table 147: OEM729 COM1 or PwrPak7 to OEM-IMU-STIM300 pin connections

STIM300		Receiver		Description
Pin	Pin name	Pin	Pin name	
1	STIM TxD-	OEM729 COM1: 15 PwrPak7 COM1: 4 COM2: 12	COMx_ RXD-	Part of RS-422 transmit pair from STIM300
2	STIM RxD-	OEM729 COM1: 17 PwrPak7 COM1: 1 COM2: 19	COMx_ TXD-	Part of RS-422 receive pair from STIM300
4	STIM TOV	OEM729: 7 PwrPak7: 23	EVENT_ IN2	<div style="border: 1px solid red; padding: 5px; background-color: #ffe6e6;">  <p>Interface Circuit Required The STIM TOV output uses 5V logic, but the OEM729 EVENT_IN lines are not 5V tolerant. A circuit to convert from 5V logic to 3.3V levels is required on the OEM729.</p> </div> <p>The PwrPak7 input strobes are 5V tolerant and can be connected directly to the STIM TOV output.</p>
8	5V Pwr	–	–	5 VDC power supply
9	STIM TxD+	OEM729 COM1: 18 PwrPak7 COM1: 3 COM2: 20	COMx_ RXD+	Part of RS-422 transmit pair from STIM300
10	STIM RxD+	OEM729 COM1: 20 PwrPak7 COM1: 2 COM2: 10	COMx_ TXD+	Part of RS-422 receive pair from STIM300
12	GND	OEM729 GND: 1, 23, 24 PwrPak7 GND: 11, 14, 17	GND	Connect the STIM300 ground pin to any receiver ground pin. This establishes a common ground and ensures proper signal detection.
13	GND			
15	GND			



For the location of the receiver ground pins and transmit and receive pairs, refer to the [OEM7 Installation and Operation User Manual](#) or [PwrPak7 Installation and Operation User Manual](#).

For more information about connecting using a SPI port, refer to *Connect an OEM-IMU-STIM300 directly to an OEM7 receiver* on page 45.

A.18.5 OEM-IMU-STIM300 IMU-to-MIC cable assembly

The NovAtel part number for the OEM-IMU-STIM300 IMU-to-MIC interface cable is 01019161 (*Figure 94: OEM-IMU-STIM300 IMU-to-MIC cable assembly* below). This cable provides power to the IMU and enables communication between the MIC and the IMU.



In the following diagram, the dimensions are in millimetres.

Figure 94: OEM-IMU-STIM300 IMU-to-MIC cable assembly

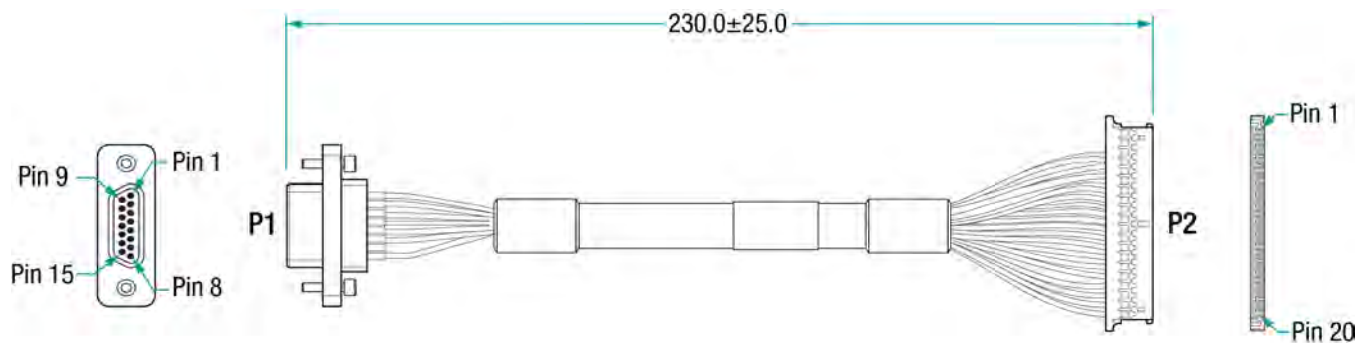

Pins not shown on the following table are not connected.

Table 148: OEM-IMU-STIM300 IMU-to-MIC cable pinout

P2 pin (MIC)	Signal	P1 pin (STIM300)
6	Ground	12
7	Ground	13
8	VSUP (5V input)	8
9	VSUP (5V input)	
10	Ground	15
11	Transmit Data+	10
12	Transmit Data-	2
13	Receive Data+	9
14	Receive Data-	1
17	IMU DAS	4
19	IMUTYPE1	15

A.19 OEM-IMU- μ IMU-IC / OEM-IMU- μ IMU-IC-UART



The specifications in this section apply to both the OEM-IMU- μ IMU-IC and OEM-IMU- μ IMU-IC-UART.



The OEM-IMU- μ IMU-IC requires a Universal IMU Controller to connect to a NovAtel receiver. See *UIC – Universal IMU Controller* on page 290.

Table 149: OEM-IMU- μ IMU-IC / OEM-IMU- μ IMU-IC-UART physical specifications

Physical	
IMU size (\varnothing x H)	85 mm x 60 mm
IMU weight	0.68 kg

See the following sections for more information about the OEM-IMU- μ IMU-IC / OEM-IMU- μ IMU-IC-UART.

- *OEM-IMU- μ IMU-IC / OEM-IMU- μ IMU-IC-UART mechanical drawings* on page 271
- *OEM-IMU- μ IMU-IC / OEM-IMU- μ IMU-IC-UART sensor specifications* on page 273
- *OEM-IMU- μ IMU-IC / OEM-IMU- μ IMU-IC-UART electrical and environmental* on page 274
- *OEM-IMU- μ IMU-IC to UIC cable assembly* on page 275

A.19.1 OEM-IMU- μ IMU-IC / OEM-IMU- μ IMU-IC-UART comparison

While the OEM-IMU- μ IMU-IC and OEM-IMU- μ IMU-IC-UART provide the same SPAN performance, there are differences in how the IMU is integrated into the SPAN system.

	OEM-IMU- μ IMU-IC	OEM-IMU- μ IMU-IC-UART
Communication connection	The UIC provides the communication interface between the IMU and receiver.	The IMU connects directly to a receiver serial port.
Input voltage	The UIC provides power to the IMU. The UIC requires 10 – 34 VDC. See <i>UIC electrical and environmental</i> on page 294.	The IMU requires 5 VDC.
Power consumption	<8 W + 4W for the UIC	<8 W
DMI input	Yes. DMI input is handled by the UIC.	No. Requires manual input of wheel ticks using the RAWDMI command.
Event signals	The UIC handles timing with the IMU.	Requires the SYNCOUT signal on the IMU to be connected to an EVENTIN on the receiver. (EVENTIN2 is the default)

	OEM-IMU- μ IMU-IC	OEM-IMU- μ IMU-IC-UART
Cables	An IMU to UIC cable is available from NovAtel. See <i>OEM-IMU-μIMU-IC to UIC cable assembly</i> on page 275.	A cable is not available from NovAtel. A Micro-D 31 connector is required on the IMU end of the cable.

A.19.2 OEM-IMU- μ IMU-IC / OEM-IMU- μ IMU-IC-UART mechanical drawings



The following graphics are courtesy of Northrop Grumman LITEF GmbH.



In the following diagrams, the dimensions are in millimetres.

Figure 95: OEM-IMU- μ IMU-IC / OEM-IMU- μ IMU-IC-UART top dimensions

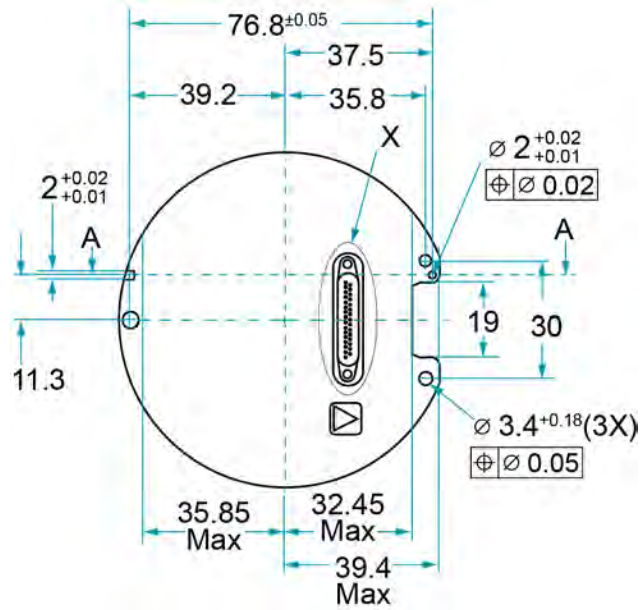

Figure 96: OEM-IMU- μ IMU-IC / OEM-IMU- μ IMU-IC-UART side dimensions

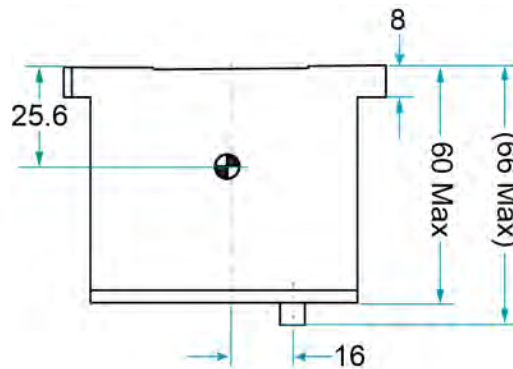

Figure 97: OEM-IMU- μ IMU-IC / OEM-IMU- μ IMU-IC-UART bottom dimensions

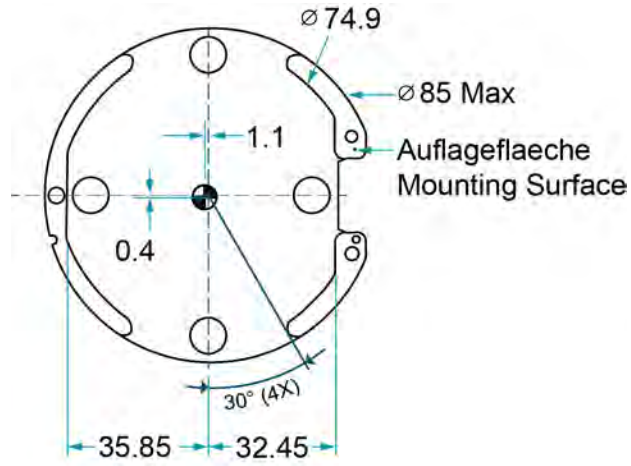
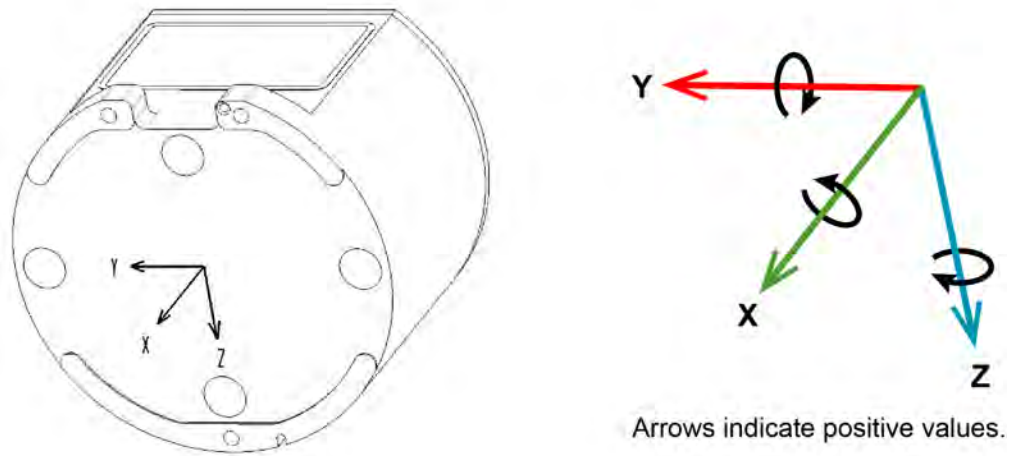

Figure 98: OEM-IMU- μ IMU-IC / OEM-IMU- μ IMU-IC-UART coordinate axis



A.19.3 OEM-IMU- μ IMU-IC / OEM-IMU- μ IMU-IC-UART sensor specifications

Table 150: OEM-IMU- μ IMU-IC / OEM-IMU- μ IMU-IC-UART performance

Gyroscope performance	
Technology	MEMS
Dynamic range	499 °/s
Bias instability ¹	6 °/hr
Angular random walk ¹	0.12 °/ $\sqrt{\text{hr}}$
Accelerometer performance	
Technology	MEMS
Dynamic range	15 g
Bias instability ¹	3 mg
Velocity random walk ¹	0.15 m/s/ $\sqrt{\text{hr}}$
Data rate	
IMU measurement	
OEM-IMU- μ IMU-IC	200 Hz
OEM-IMU- μ IMU-IC-UART	400 Hz

1. Maximum value over temperature and lifetime estimations.

A.19.4 OEM-IMU- μ IMU-IC / OEM-IMU- μ IMU-IC-UART electrical and environmental**Table 151: OEM-IMU- μ IMU-IC electrical specifications**

Electrical	
Input power	+5.0 VDC Provided by the UIC. See <i>UIC electrical and environmental</i> on page 294.
Power consumption	<8 W
Recommended fuse	2.5 A slow blow
Connector	31 pin Micro-D, plug

Table 152: OEM-IMU- μ IMU-IC-UART electrical specifications

Electrical	
Input power	+5.0 VDC
Power consumption	<8 W
Recommended fuse	2.5 A slow blow
Connector	31 pin Micro-D, plug

Table 153: OEM-IMU- μ IMU-IC / OEM-IMU- μ IMU-IC-UART environmental specifications

Environmental	
Temperature, operational	-45°C to +70°C
Temperature, storage 48 hours	-55°C to +71°C

A.19.5 OEM-IMU- μ IMU-IC to UIC cable assembly

The NovAtel part number for the OEM-IMU- μ IMU-IC to UIC interface cable is 01019760 (*Figure 99: OEM-IMU- μ IMU-IC to UIC cable assembly* below). This cable provides power to the IMU and enables communication between the UIC and the IMU.



In the following diagram, the dimensions are in millimetres.

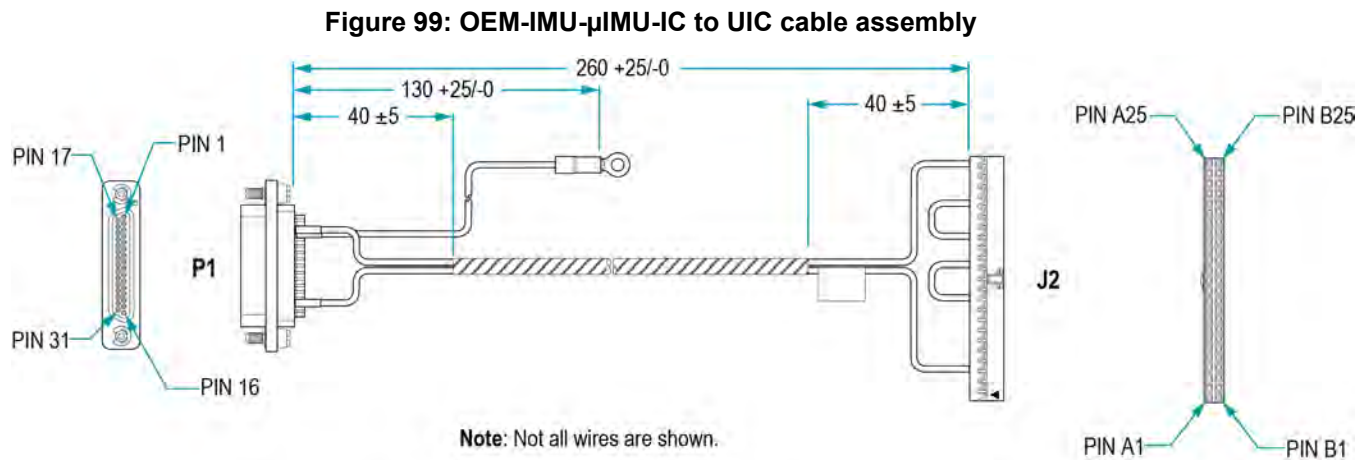

Table 154: OEM-IMU- μ IMU-IC to UIC cable pinout

P1 pin (μ IMU)	Signal	J2 pin (UIC)
1	Ground	B2
2	Ground	A3
3	Transmit Data+	B20
4	Transmit Data-	B19
5	Transmit Clock-	B15
6	Transmit Clock+	B16
7	Ground	B3
8	Ground	B4
13	NOGO	B9
16	SYNC-	B17
17	IMU_5V25	A22
18	IMU_5V25	B22
19	IMU_5V25	B23
20	Ground	A21 B21

P1 pin (μ IMU)	Signal	J2 pin (UIC)
21	Ground	B5 B11
22	Ground	A23 B24
26	Lug Ring	-
27	IMU_PDWARN	B6
30	IMU_RESET	B7
31	SYNC+	B18
	IMU_TYPE_3	A15 to A18
	IMU_TYPE_1	A13 to A11

A.20 MIC – MEMS Interface Card

Table 155: MIC physical specifications

Physical	
MIC size	74.9 mm x 45.7 mm x 19.5 mm (2.94" x 1.80" x 0.76")
MIC weight	31 g (0.0683 lb)

See the following sections for more information about the MIC.

- *MIC mechanical drawings* on the next page
- *MIC electrical and environmental* on page 280
- *MIC connectors* on page 281
- *OEM-HG1930 IMU-to-MIC cable assembly* on page 286
- *HG1700 and OEM-HG1900 IMU-to-MIC cable assembly* on page 288

A.20.1 MIC mechanical drawings



In the following diagrams, the dimensions are in millimetres [inches].

Figure 100: MIC dimensions

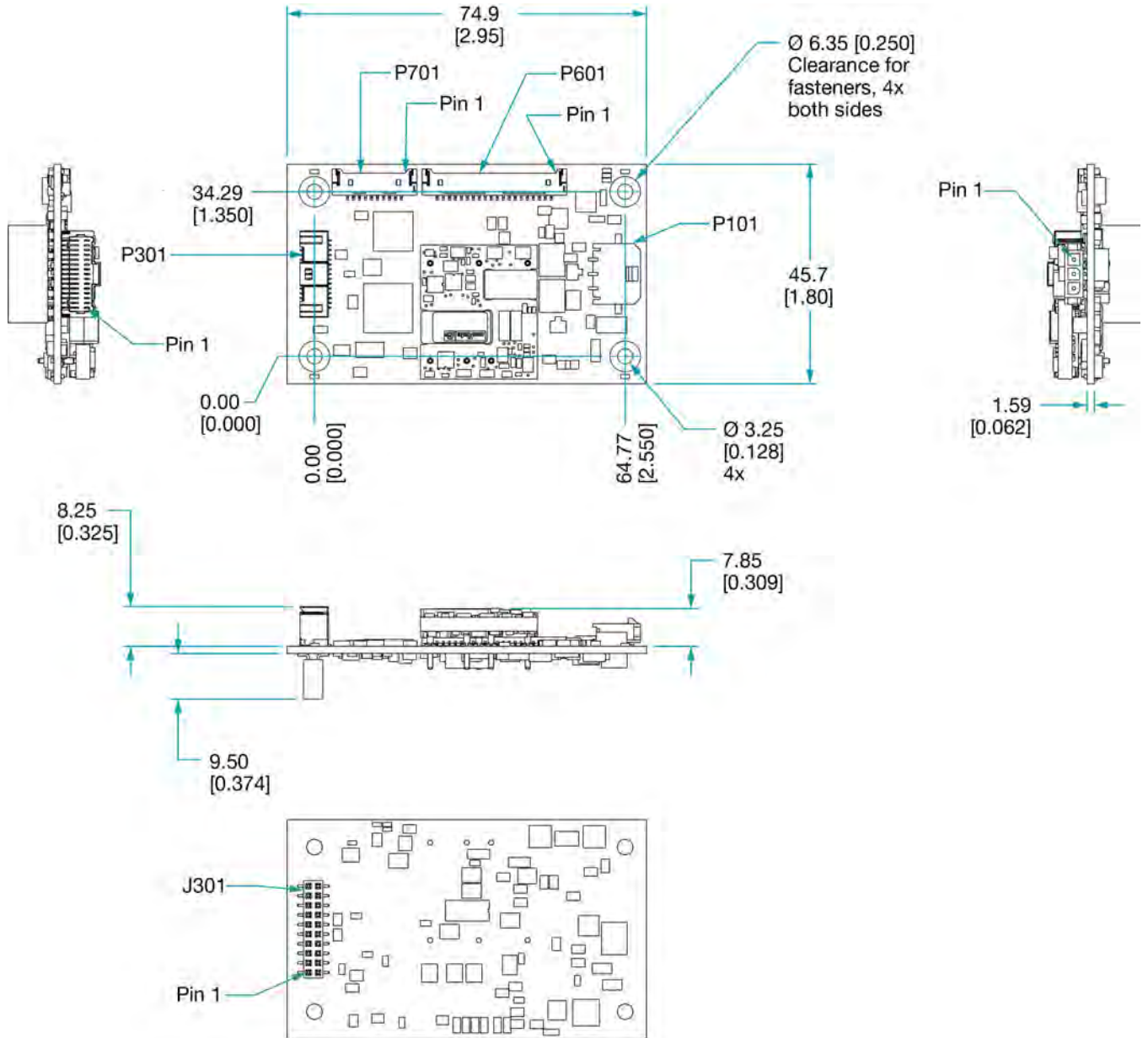
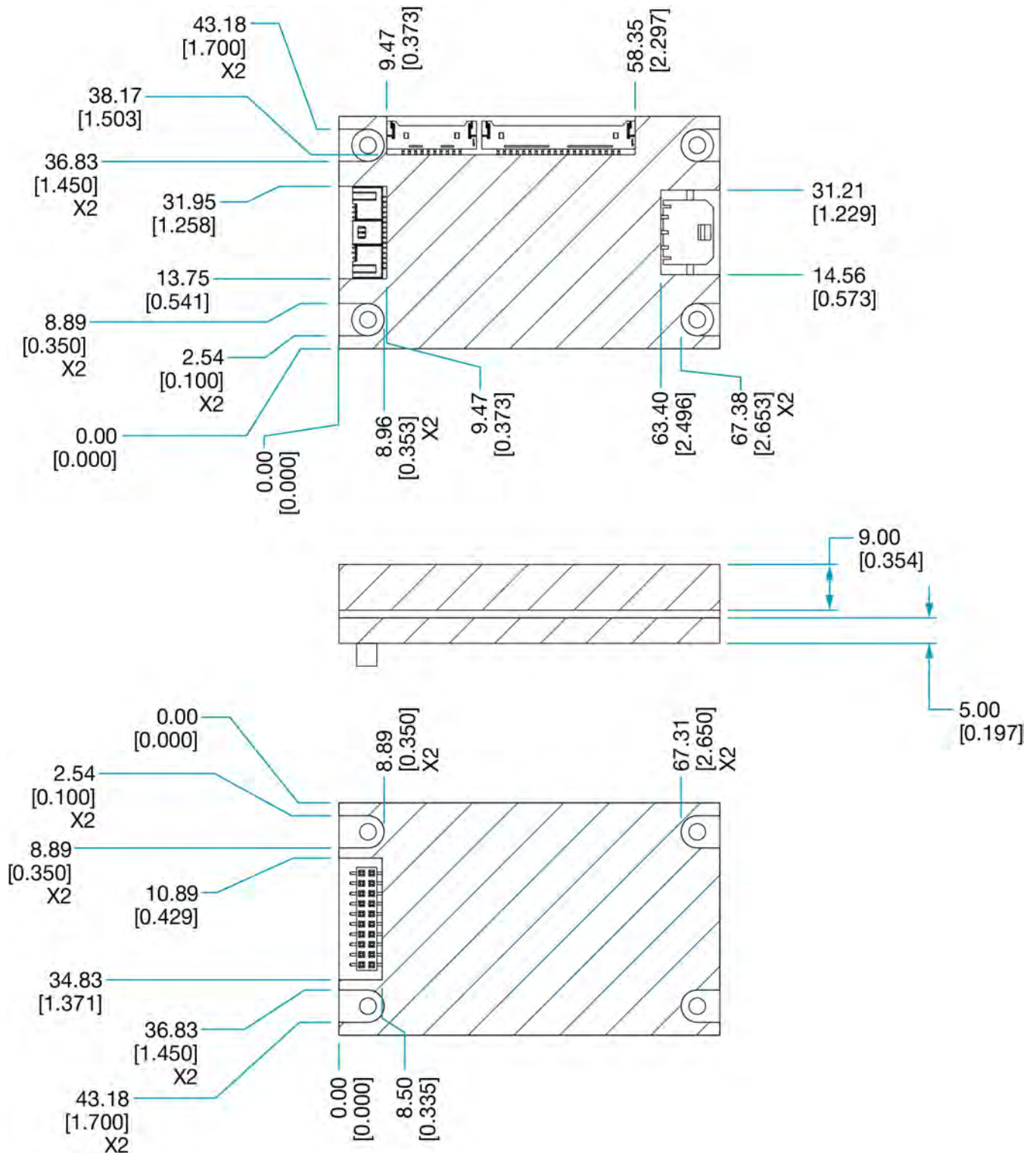

Figure 101: MIC keep-out zone



Cross hatched areas indicate “keep-out” areas intended for NovAtel circuitry. NovAtel reserves the right to modify components and component placements inside cross hatched keep-out zones, while maintaining design, form, fit and function.

A.20.2 MIC electrical and environmental

Table 156: MIC electrical specifications

Electrical	
MIC input voltage	10 VDC to 30 VDC
Power consumption ¹	+5 VDC @ 1 Amp for IMU +3.3 VDC @ 1 Amp for IMU +15 VDC @ 0.5 Amp for IMU -15 VDC @ 0.08 Amp for IMU +3.3 VDC @ 0.6 Amp for OEM719
IMU data interfaces	UART and SDLC over RS-422

Table 157: MIC environmental specifications

Environmental	
Operating temperature	-40°C to +75°C (-40°F to 167°F)
Storage temperature	-55°C to +90°C (-67°F to 194°F)
Random vibe	MIL-STD-810G (Cat 24, 7.7 g RMS)
Sine vibe	IEC 60068-2-6
Bump	IEC 68-2-29 (25 g)
Shock	MIL-STD-810G (40 g)

1. Sample system power consumption: 5.7 W when powering an OEM-HG1900 IMU and OEM719 receiver, in board stack configuration, from VIN=15 VDC at +25°C.

A.20.3 MIC connectors

Table 158: MIC connectors

Connector	Description	Part number	Mating connector part number
J301	20-pin OEM719 mating connector	ASP-163577-01 SAMTEC	Connects only to OEM719 receiver.
P101	3-pin locking power connector	43650-0313 Molex Electronics	43645-0300 Molex Electronics
P301	30-pin locking communication connector	501571-3007 Molex Electronics	501189-3010 Molex Electronics
P601	20-pin locking IMU connector for HG1700, OEM-HG1900, OEM-HG1930 and OEM-IMU-STIM300 IMUs	53780-2070 Molex Electronics	51146-2000 Molex Electronics
P701	10-pin locking IMU connector for OEM-IMU-ADIS-16488 IMUs	53780-1070 Molex Electronics	51146-1000 Molex Electronics

Table 159: Pinout for power connector (P101)

Pin	Signal	Type	Description	Comments
1	VIN+	Power	Power input	+10 VDC to +30 VDC
2	VIN-	Power	Power return	Connect to negative terminal of battery
3	GND	Power	Chassis ground	

Table 160: Pinout for user interface connector (P301)

Pin	Signal	Type	Description	Comments
1	N/C			
2	N/C			
3	LED3	Output	Status LED 3 / Self-test	
4	LED2	Output	Status LED 2 / GPS Time Status	
5	DGND	Power	Digital ground	
6	LED1	Output	Status LED 1 / IMU Data Status	

Pin	Signal	Type	Description	Comments
7	Reserved	N/A	Leave as no connect	
8	DGND	Power	Digital ground	
9	Reserved	N/A	Leave as no connect	
10	Reserved	N/A	Leave as no connect	
11	N/C	N/A		
12	N/C	N/A		
13	USB D-	Bidirectional	USB interface data (-)	Only available in board stackup with OEM719 In standalone, no connect
14	USB D+/ COM3 RX	Bidirectional	USB interface data (+)/ COM3 receive data	Only available in board stackup with OEM719 In standalone, no connect The USB port is enabled by default and the COM3 port is disabled by default. If you enable the COM3 port, the USB port is disabled.
15	RESETIN	Input	OEM719 reset in	Only available in board stackup with OEM719 In standalone, no connect
16	VARF/ CAN1 RX	Output/ Input	Variable frequency output/ CAN1 receive data	Only available in board stackup with OEM719 In standalone, no connect The VARF output is enabled by default and the CAN1RX input is disabled by default. If you disable VARF, the CAN1RX input is enabled.
17	EVENT2/ CAN1 TX	Input/ Output	Event2 input/ CAN1 transmit data	Only available in board stackup with OEM719 In standalone, no connect The Event2 input is enabled by default and the CAN1TX output is disabled by default. If you disable EVENT2, the CAN1TX output is enabled.
18	CAN2 RX	Input	CAN2 receive data	Only available in board stackup with OEM719 In standalone, no connect
19	EVENT1/ COM3 TX	Input	Event1 input/ COM3 transmit data	Only available in board stackup with OEM719 In standalone, no connect The Event1 input is enabled by default and the COM3 port is disabled by default. If you enable the COM3 port, the Event1 input is disabled.
20	DGND	Power	Digital ground	

Pin	Signal	Type	Description	Comments
21	MIC TX	Output		In board stackup with OEM719, this pin is for firmware download In standalone use, this pin can be used for either firmware download and/or for IMU data communication to a SPAN receiver
22	MIC RX	Input		In board stackup with OEM719, this pin is for firmware download In standalone use, this pin can be used for either firmware download and/or for IMU data communication to a SPAN receiver
23	DGND	Power		
24	USER_TXD2	Output		In board stackup with OEM719, this is the access to the OEM719 COM2 port In standalone, no connect
25	USER_RXD2	Input		In board stackup with OEM719, this is the access to the OEM719 COM2 port In standalone, no connect
26	DGND	Power	Digital ground	
27	PV	Output	Access to OEM719 position valid	Only available in board stackup with OEM719 In standalone, no connect
28	DGND	Power	Digital ground	
29	1PPS	Output	Access to OEM719 1PPS	Only available in board stackup with OEM719 In standalone, no connect
30	CAN2 TX	Output	CAN2 transmit data	Only available in board stackup with OEM719 In standalone, no connect



All signal I/O with the exception of USB port are at LVCMOS levels.

Table 161: Pinout for IMU connector (P601)

Pin	Signal	Type	Description	Comments
1	GND		Chassis ground	
2	GND		Chassis ground	
3	15V	Output Power	Positive 15 VDC supply	Enabled/disabled depending on the IMU type detected

Pin	Signal	Type	Description	Comments
4	15V	Output Power	Positive 15 VDC supply	Enabled/disabled depending on the IMU type detected
5	-15V	Output Power	Negative 15 VDC supply	Enabled/disabled depending on the IMU type detected
6	DGND		Digital ground	Enabled/disabled depending on the IMU type detected
7	DGND		Digital ground	Enabled/disabled depending on the IMU type detected
8	IMU VDD	Output Power	Positive voltage supply for IMU logic circuits	IMU_VDD can be +3.3 VDC or +5 VDC depending on the IMU type detected
9	IMU VDD	Output Power	Positive voltage supply for IMU logic circuits	
10	DGND	Power	Digital ground	
11	Tx Data+	Output	Serial data out+	Non-inverting
12	Tx Data-	Output	Serial data out-	Inverting
13	RX Data+	Input	Serial data in+	Non-inverting RS-422 data input
14	RX Data-	Input	Serial data in-	Inverting RS-422 data input
15	CLK+	Bidirectional	Serial data clock+	Non-inverting portion of RS-422 link
16	CLK-	Bidirectional	Serial data clock-	Inverting portion of RS-422 link
17	IMU DAS	Bidirectional	Data acquisition signal	Provides synchronization for IMU data (LVCMOS level)
18	IMUTYPE0	Input	detect IMU type	LVCMOS level, not 5V tolerant
19	IMUTYPE1	Input	detect IMU type	LVCMOS level, not 5V tolerant
20	IMUTYPE2	Input	detect IMU type	LVCMOS level, not 5V tolerant



All signal I/O are at LVCMOS levels.

Table 162: Pinout for IMU connector (P701)

Pin	Signal	Type	Description	Comments
1	IMU_VDD	Output Power	Positive voltage supply for IMU logic circuits	IMU_VDD must be +3.3 VDC
2	IMU_VDD	Output Power	Positive voltage supply for IMU logic circuits	
3	SPI_NSS		Slave Select	LVCMOS level, not 5V tolerant
4	SPI_SCK	Output	Serial Clock	LVCMOS level, not 5V tolerant

Pin	Signal	Type	Description	Comments
5	DGND		Digital Ground	
6	SPI_MOSI	Output	Master Output / Slave Input	LVC MOS level, not 5V tolerant
7	SPI_MISO	Input	Master Input / Slave Output	LVC MOS level, not 5V tolerant
8	DGND		Digital Ground	
9	IMU_DIO1	Bidirectional		LVC MOS level, not 5V tolerant
10	IMU_DIO2	Bidirectional		LVC MOS level, not 5V tolerant

Table 163: MIC LED indicator drivers

Board state	Status LED 1	Status LED 2	Status LED 3
Bootup	Toggles at 2 Hz Self-test	Off	On
Normal Operation	On	Toggles at 2 Hz GPS Time	Toggles at 2 Hz IMU Data
No IMU Connected	Toggles at 1 Hz Error	Toggles at 2 Hz GPS Time	Toggles at 1 Hz Error



When the MIC boots up, it requires approximately 10 seconds to perform a self-test.

If a software update has been performed, the board can take up to 70 seconds at startup to complete the reprogramming.

A.20.4 OEM-HG1930 IMU-to-MIC cable assembly

The NovAtel part number for the OEM-HG1930 IMU-to-MIC interface cable is 01018827 (*Figure 102: OEM-HG1930 IMU-to-MIC cable assembly* below). This cable provides power to the IMU and enables communication between the MIC and the IMU.



In the following diagram, the dimensions are in millimetres.

Figure 102: OEM-HG1930 IMU-to-MIC cable assembly

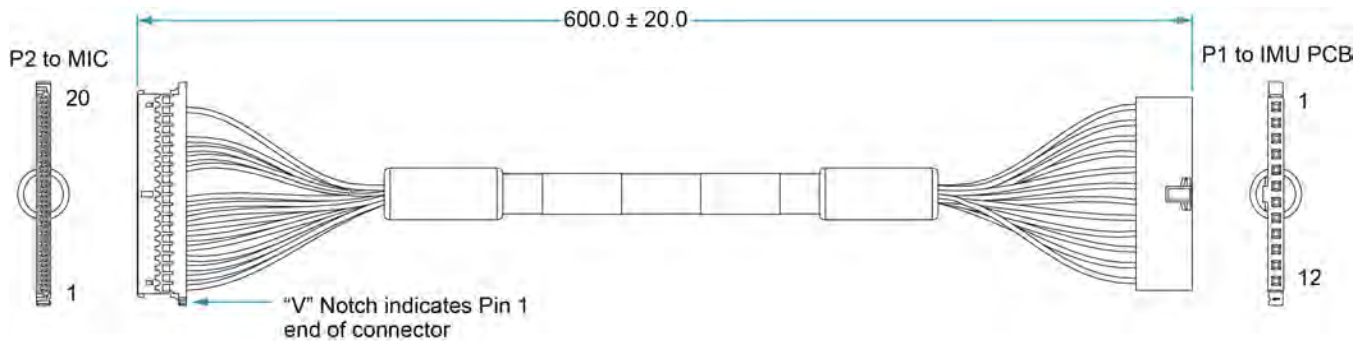

Table 164: OEM-HG1930 IMU-to-MIC cable assembly

P1 IMU cable end (FCI-MINITEK) Pin	P2 MIC cable end Pin
1	15
2	16
3	13
4	14
5	8
7	7
6	9
8	10
11	3
	4
12	6
	19
9	5
10	1
	2



For more information, refer to the IMU documentation provided by Honeywell.

A.20.5 HG1700 and OEM-HG1900 IMU-to-MIC cable assembly

The NovAtel part number for the HG1700 and OEM-HG1900 IMU-to-MIC interface cable is 01018828 (Figure 103: HG1700 and OEM-HG1900 IMU-to-MIC cable assembly below). This cable provides power to the IMU and enables communication between the MIC and the IMU.



In the following diagram, the dimensions are in millimetres.

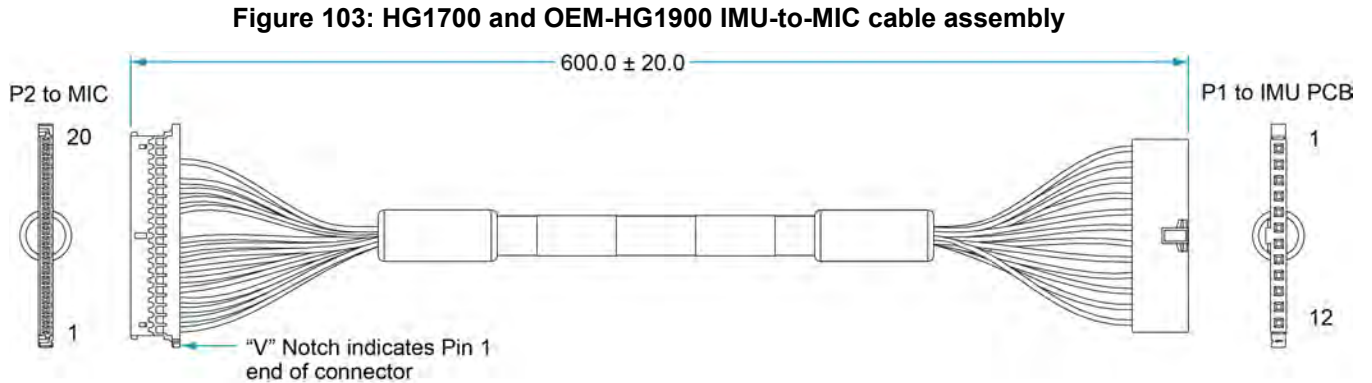

Table 165: HG1700 and OEM-HG1900 IMU-to-MIC cable assembly

P1 IMU cable end (FCI-MINITEK)	P2 MIC cable end
Pin	Pin
1	15
2	16
3	13
4	14
5	8
7	7
6	9
8	10
11	3
	4
12	6
	18
9	5
10	1
	2



For more information, refer to the IMU documentation provided by Honeywell.

A.21 UIC – Universal IMU Controller

Table 166: UIC physical specifications

Physical	
UIC size	100 mm x 113 mm x 17.54 mm (3.94" x 4.45" x 0.69")
UIC weight	125 g (0.28 lb)

See the following sections for more information about the UIC.

- *UIC mechanical drawings* on the next page
- *UIC electrical and environmental* on page 294
- *UIC connectors* on page 295
- *OEM-HG1900 IMU to UIC cable assembly* on page 299
- *LN200 IMU to UIC cable assembly* on page 300

A.21.1 UIC mechanical drawings



In the following diagrams, the dimensions are in millimetres.

Figure 104: UIC dimensions and keep out zones

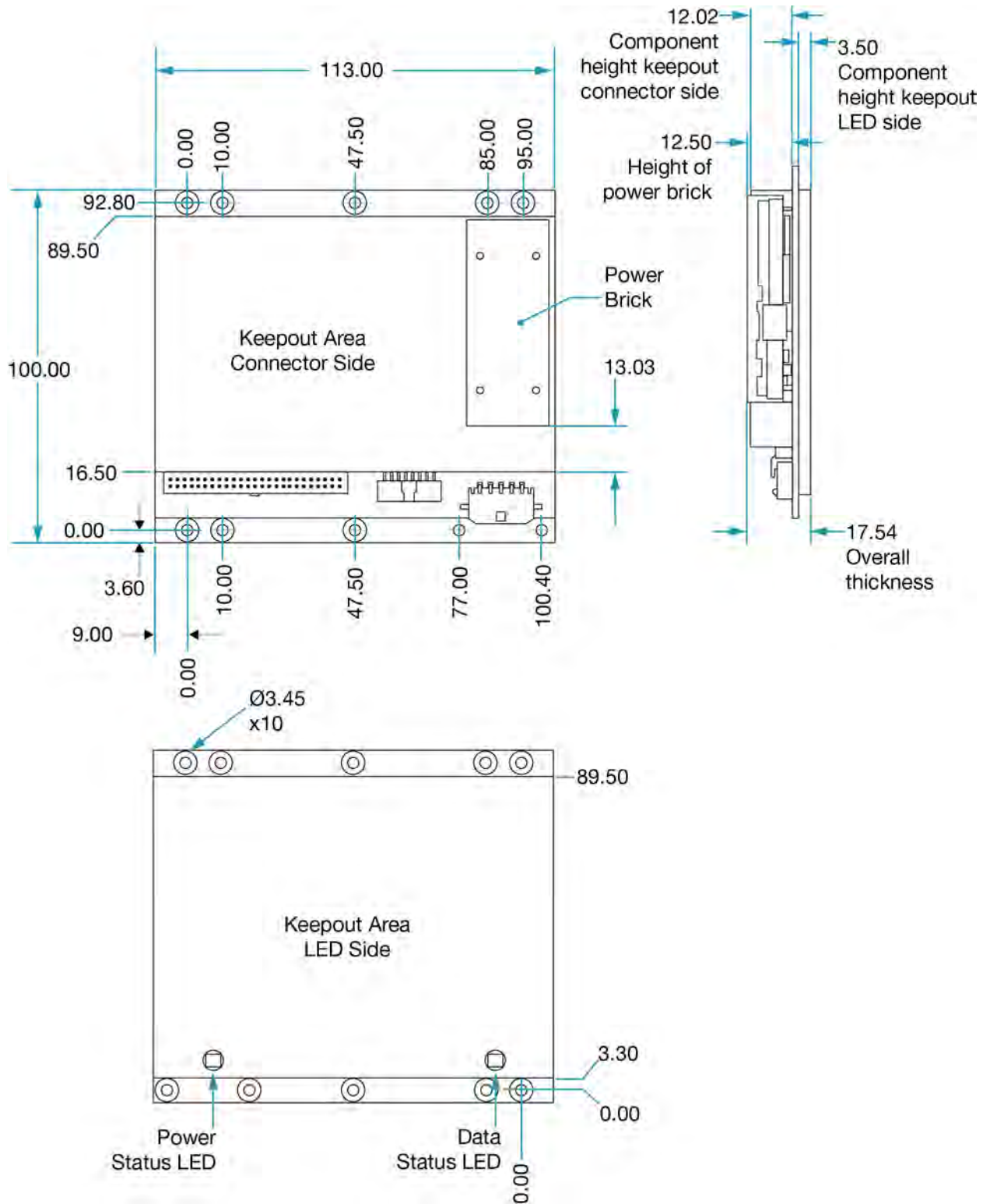
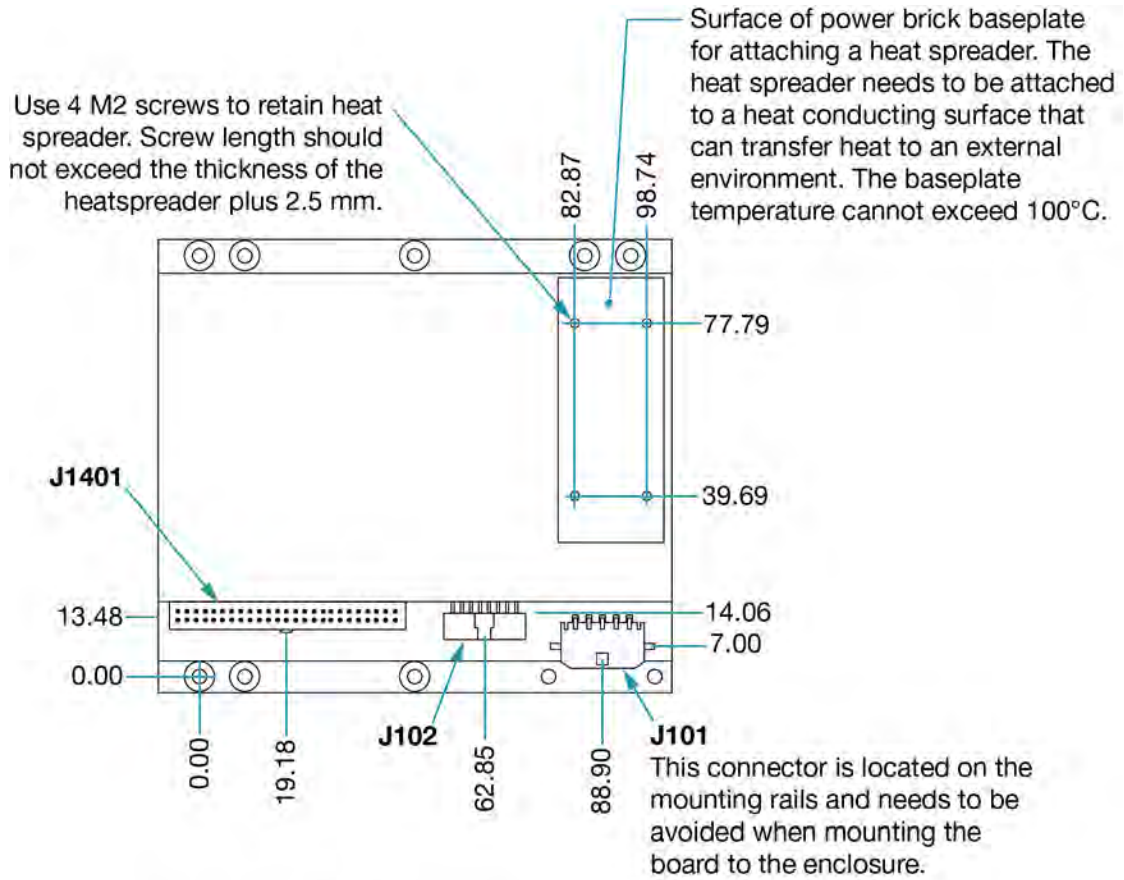
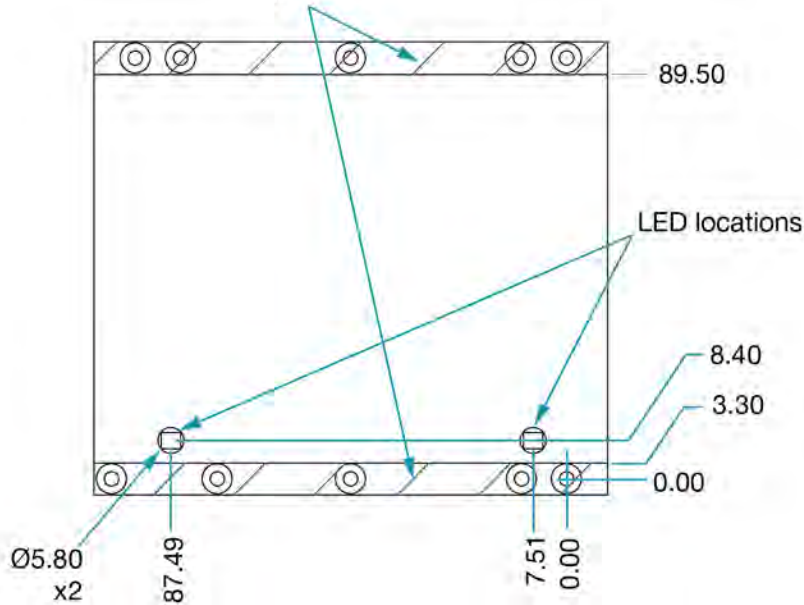

Figure 105: UIC connectors, LEDs and heat sink details



Cross hatching indicates mounting rail on both sides with noted exception for J101 connector.



A.21.2 UIC electrical and environmental**Table 167: UIC electrical specifications**

Electrical	
UIC input voltage	10 VDC to 34 VDC
Power consumption (at 12 VDC input)	4 W
IMU data interfaces	UART and SDLC over RS-422

Table 168: UIC environmental specifications

Environmental	
Operating temperature	-40°C to +75°C (-40°F to 167°F)
Storage temperature	-55°C to +90°C (-67°F to 194°F)
Random vibe	MIL-STD-810G (Cat 24, 7.7 g RMS)
Sine vibe	IEC 60068-2-6
Bump	IEC 68-2-29 (25 g)
Shock	MIL-STD-810G (40 g)

A.21.3 UIC connectors

Table 169: UIC connectors

Connector	Description	Part number	Mating connector part number
J101	5-pin UIC power connector ¹	43650-0513 Molex Electronics	43645-0500 Molex Electronics
J102	16-pin UIC to receiver communication connector ²	98464-G61-16LF FCI Electronics	90311-016LF FCI Electronics
J1401	50-pin UIC to IMU communication connector	LTMM-125-02-L-D (Samtec)	SQT-125-01-L-D (Samtec)

Table 170: Pinout for power connector (J101)

Pin	Signal	Type	Description	Comments
1	VIN+	Power	Power input	+10 VDC to +34 VDC
2	VIN+	Power	Power input	+10 VDC to +34 VDC
3	VIN-	Power	Power return	Connect to negative terminal of battery
4	VIN-	Power	Power return	Connect to negative terminal of battery
5	GND	Power	Chassis ground	

Table 171: Pinout for UIC to receiver communications connector (J102)

Pin	Signal ³	Type	Description	Comments
A1	UIC_RX+	Input	RS-422 serial data in+	RS-422 serial port for UIC to receiver communication
A2	UIC_RX-	Input	RS-422 serial data in-	
A3	UIC_TX+	Output	RS-422 serial data out+	
A4	UIC_TX-	Output	RS-422 serial data out-	
A5	A+	Input	Wheel sensor input A (+)	Connects to the wheel sensor.
A6	A-	Input	Wheel sensor input A (-)	Connects to the wheel sensor.
A7	Reserved			
A8	Reserved			

1. A filter module (similar to Delta FL 75L07) in series with the power cable maybe needed to pass conducted emission.

2. A tubular ferrite bead (similar to Laird Technologies 28B0375-300) maybe attached to the data cable to reduce radiated emissions.

3. All signal I/O are at LVCMOS levels (not 5V tolerant).

Pin	Signal1	Type	Description	Comments
B1	Reserved			
B2	Reserved			
B3	EVENT_OUT+	Output	Event output (+)	
B4	EVENT_OUT-	Output	Event output (-)	
B5	B+	Input	Wheel sensor input B (+)	Connects to the wheel sensor.
B6	B-	Input	Wheel sensor input B (-)	Connects to the wheel sensor.
B7	Reserved (do not connect)			
B8	CGND	Power	Chassis ground	

Table 172: Pinout for UIC to IMU communications connector (J1401)

Pin	Signal2	Type	Description
1	3.3V	Output Power	Positive 3.3 VDC supply
2	3.3V	Output Power	Positive 3.3 VDC supply
3	3.3V	Output Power	Positive 3.3 VDC supply
4	GND	Power	Digital ground
5	GND	Power	Digital ground
6	GND	Power	Digital ground
7	15V	Output Power	Positive 15 VDC supply
8	GND	Power	Digital ground
9	-15V	Output Power	Negative 15 VDC supply
10	GND	Power	Digital ground
11	NSS		SPI Slave Select
12	PWRDOWNx	Output	Power down warning
13	SCK	Output	SPI Serial Clock
14	RESETIMUx	Output	Reset IMU
15	GND	Power	Digital ground
16	GND	Power	Digital ground
17	MISO	Input	SPI Master Input / Slave Output

1. All signal I/O are at LVCMOS levels (not 5V tolerant).

2. All signal I/O are at LVCMOS levels (not 5V tolerant).

Pin	Signal1	Type	Description
18	NOGOx		
19	MOSI	Output	SPI Master Output / Slave Input
20	DIO2		
21	GND	Power	Digital ground
22	GND	Power	Digital ground
23	IMU_TYPE0	Input	Detect IMU type 0
24	IMU_EVENT_IN		
25	IMU_TYPE1	Input	Detect IMU type 1
26	IMU_EVENT_OUT		
27	IMU_TYPE2	Input	Detect IMU type 2
28	GND	Power	Digital ground
29	IMU_TYPE3	Input	Detect IMU type 3
30	TXC-		
31	IMU_DATA_OUT1-		
32	TXC+		
33	IMU_DATA_OUT1+		
34	SYNC-		
35	GND	Power	Digital ground
36	SYNC+		
37	IMU_DATA_OUT2-		
38	TXD-		
39	IMU_DATA_OUT2+		
40	TXD+		
41	GND	Power	Digital ground
42	GND	Power	Digital ground
43	5.25V	Output Power	Positive 5.25 VDC supply
44	5.25V	Output Power	Positive 5.25 VDC supply
45	GND	Power	Digital ground
46	5.25V	Output Power	Positive 5.25 VDC supply

1. All signal I/O are at LVCMOS levels (not 5V tolerant).

Pin	Signal1	Type	Description
47	GND	Power	Digital ground
48	GND	Power	Digital ground
49	-5.25V	Output Power	Negative 5.25 VDC supply
50	-5.25V	Output Power	Negative 5.25 VDC supply

1. All signal I/O are at LVCMOS levels (not 5V tolerant).

A.21.4 OEM-HG1900 IMU to UIC cable assembly

The NovAtel part number for the OEM-HG1900 IMU to UIC interface cable is 01019762 (*Figure 106: OEM-HG1900 IMU to UIC cable assembly* below). This cable provides power to the IMU and enables communication between the IMU and the UIC.



In the following diagram, the dimensions are in millimetres.

Figure 106: OEM-HG1900 IMU to UIC cable assembly

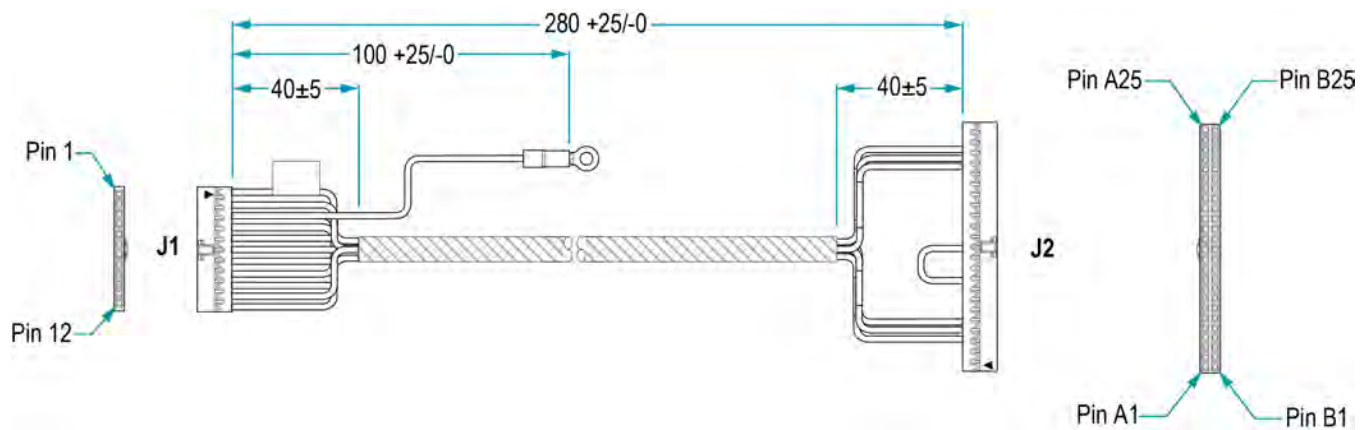

Table 173: OEM-HG1900 IMU to UIC cable pinout

J1 pin (to HG1900)	J2 pin (to UIC)
1	A3 B5
2	A4
3	Lug Ring
4	A5
5	A23
6	B21
7	B22
8	A22
9	B19
10	B20
11	A16
12	A17
	A11 to A12

A.21.5 LN200 IMU to UIC cable assembly

The NovAtel part number for the LN200 IMU to UIC interface cable is 01019763 (Figure 107: OEM-IMU-LN200 IMU to UIC cable assembly below). This cable provides power to the IMU and enables communication between the MIC and the IMU.



In the following diagram, the dimensions are in millimetres.

Figure 107: OEM-IMU-LN200 IMU to UIC cable assembly

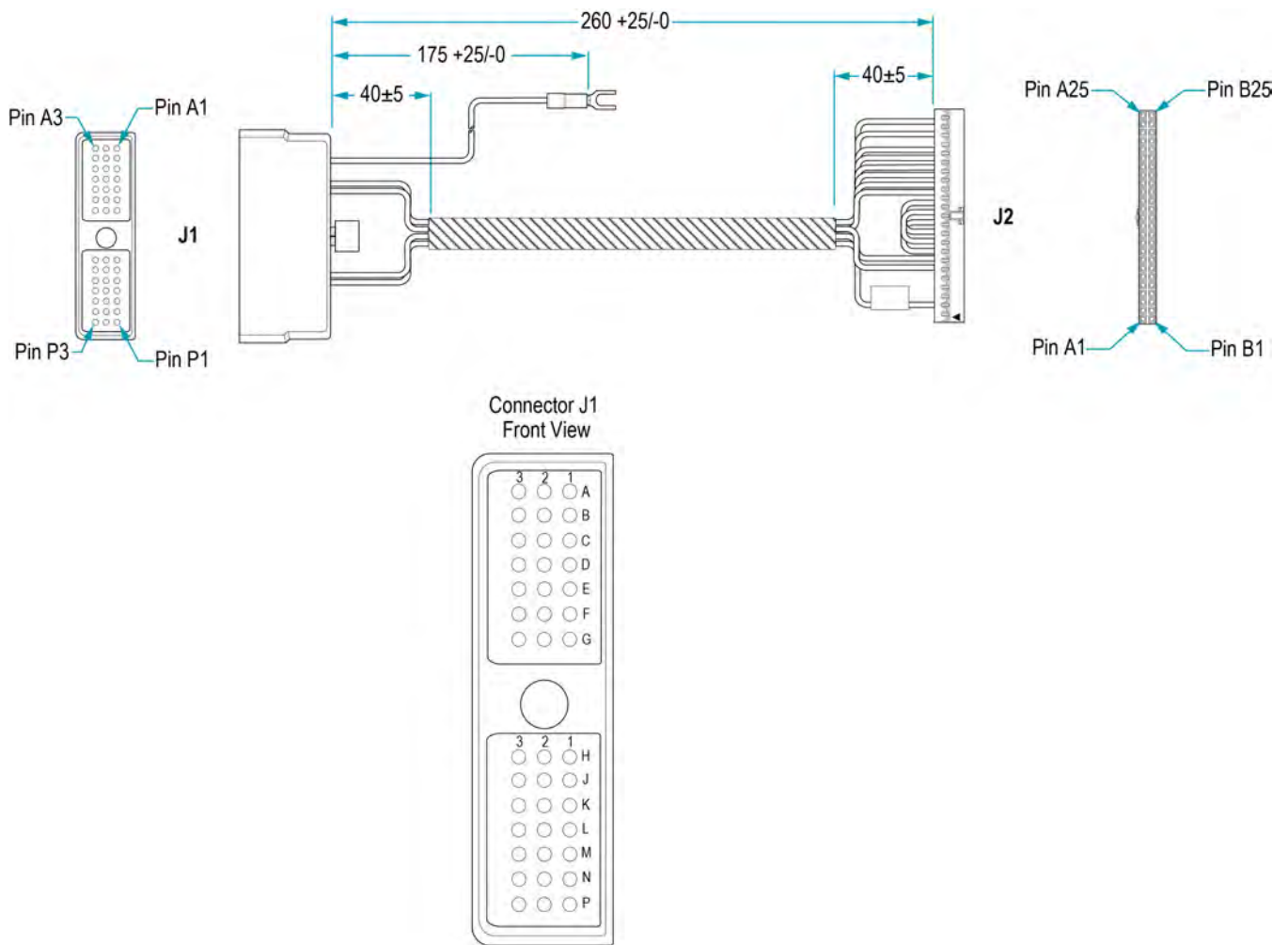

Table 174: OEM-IMU-LN200 IMU to UIC cable pinout

J1 pin (to LN200)	J2 pins(to UIC)
A2	B19
A3	B15
B1	B20
B2	B16

J1 pin (to LN200)		J2 pins(to UIC)
C1		A3 B14
D1		A24 B24
D2		A21 B21
D3		Lug Fork
E1		A22
E2		B22
E3		B23
F3		A4
G2		A5
K1		B4 B5
L2		B18
L3		B17
		A8 to A13
		A11 to 12
		A15 to A18

Appendix B HG1700 IMU in Universal Enclosure



Important! Assemble in accordance with applicable industry standards. Ensure all ESD measures are in place, in particular, use a ground strap before exposing or handling any electronic items, including the IMU. Take care to prevent damaging or marring painted surfaces, O-rings, sealing surfaces and the IMU.

The following procedure provides the necessary information to install the HG1700 sensor into the Universal Enclosure (NovAtel part number 01018589), both illustrated below. The steps required for this procedure are:

- Disassemble the Universal Enclosure
- Install the HG1700 Sensor Unit
- Reassemble the Universal Enclosure

Figure 108: Required parts

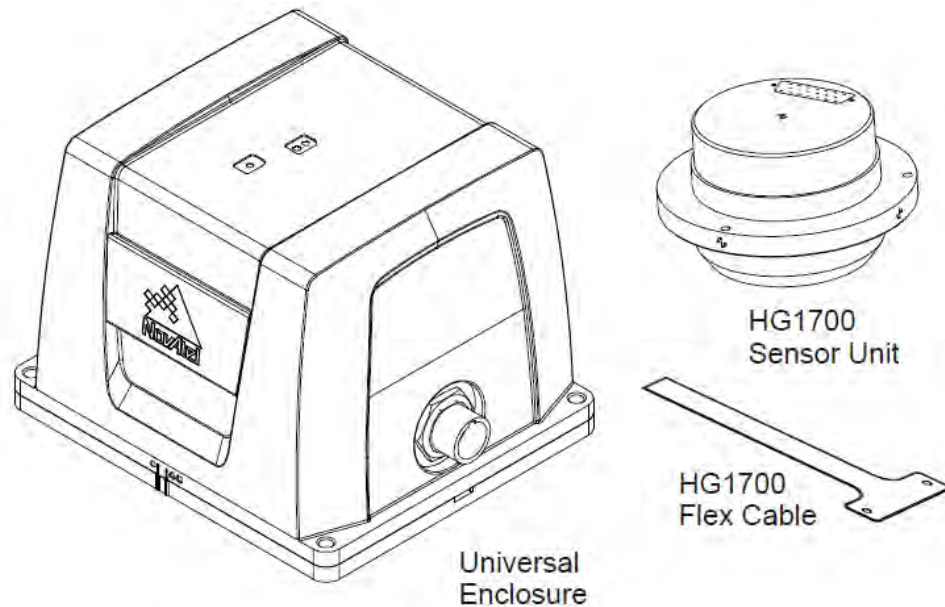

Use thread-locking fluid on all fasteners except for the flex cable connectors.



Torque values for all fasteners, including those for the flex cable, are as follows:

- Size 2-56: 0.20-0.25 N-m (1.8-2.2 lb-in) [28-35 oz/in]
- Size M4: 1.36-1.58 N-m (12.0-14.0 lb-in)
- Size 8-32: 1.55-1.70 N-m (13.7-15.0 lb-in)

B.1 Disassemble the Universal enclosure

Disassemble the Universal Enclosure as follows:

1. Using a 3 mm hex bit, remove the M4 screws (they will be reused) and the base, as shown in *Figure 109: Remove base* below. Ensure the O-rings come with the base when it is removed, and that they are not damaged.

Figure 109: Remove base

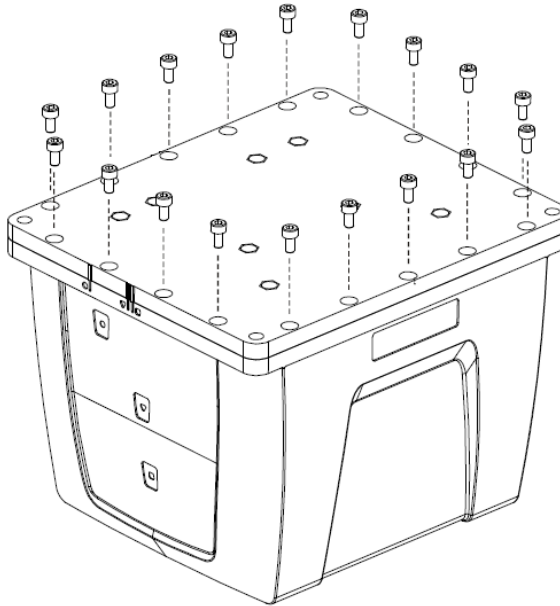

2. Using a 30 mm socket, remove the jam nut and free the wiring harness connector from the body, as shown in *Figure 110: Disconnect wiring harness from enclosure body* below. Retain the O-ring and the jam nut for reassembly.

Figure 110: Disconnect wiring harness from enclosure body

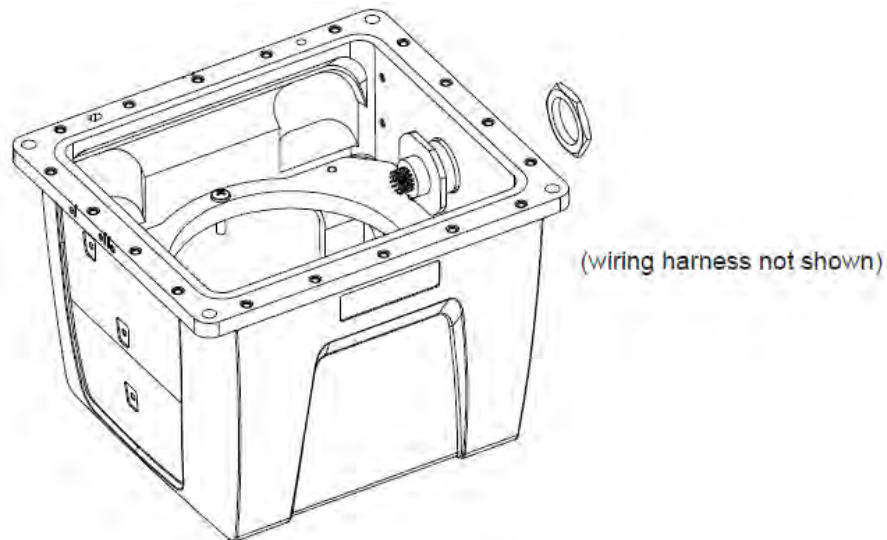

3. Using a 2.5 mm hex bit, unscrew the M4 screws and remove the IMU mounting plate, bracket and cable harness, as shown in *Figure 111: Remove IMU mounting plate and bracket* on the next page:

Figure 111: Remove IMU mounting plate and bracket

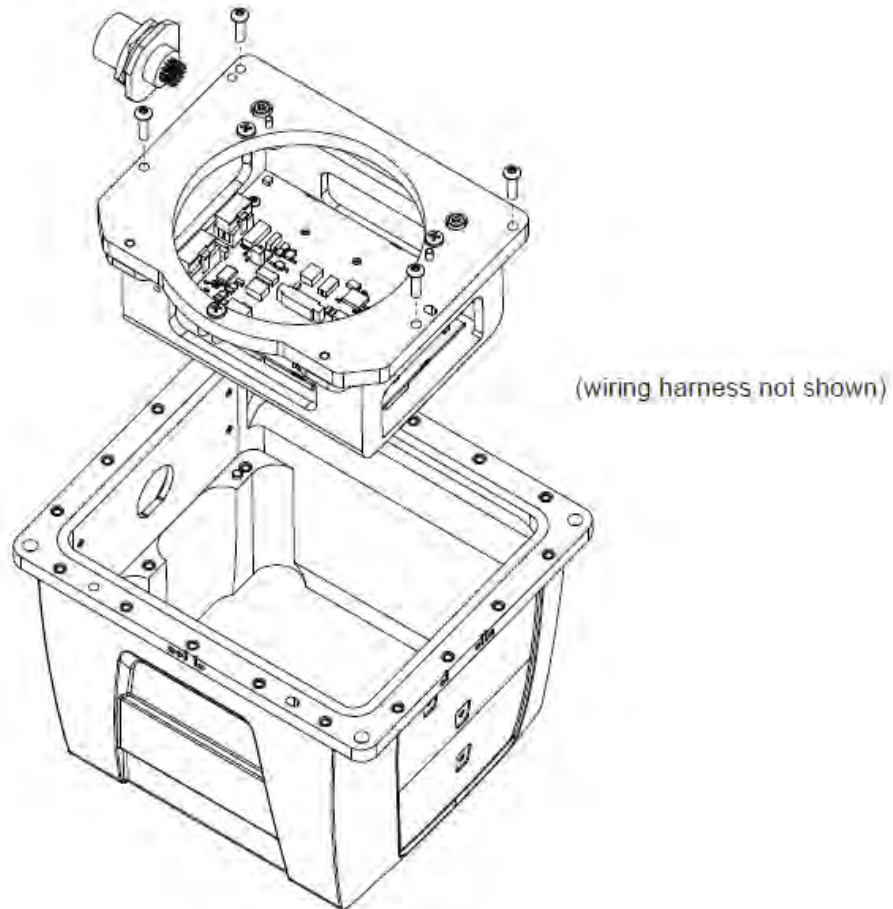

B.2 Install the HG1700 sensor unit

To install the HG1700 sensor unit in the Universal Enclosure:

1. Using a Phillips screwdriver, remove the 8-32 IMU mounting screws from the IMU mounting plate, as shown in *Figure 112: Remove IMU mounting screws* on the next page.

Figure 112: Remove IMU mounting screws

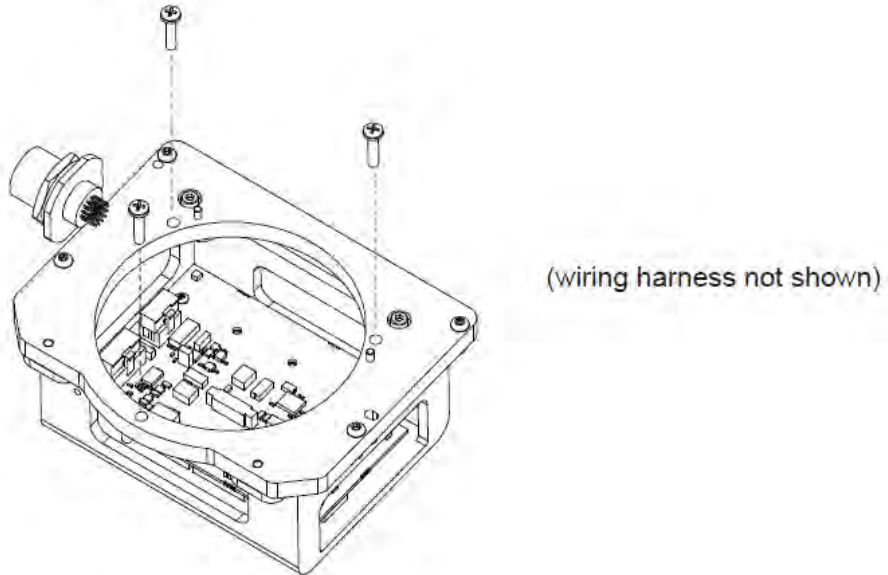

2. Check the connection of the internal cable harness to the board assembly and route as shown in *Figure 113: Connect IMU to IMU mounting plate* below. Before you connect the IMU cable harness, make sure the connector on the board assembly is clicked open. Connect the IMU cable harness to the IMU (fasten the 2-56 screws but do not use thread-locking fluid), then connect to the board assembly. Ensure the cable housing latches.

Figure 113: Connect IMU to IMU mounting plate

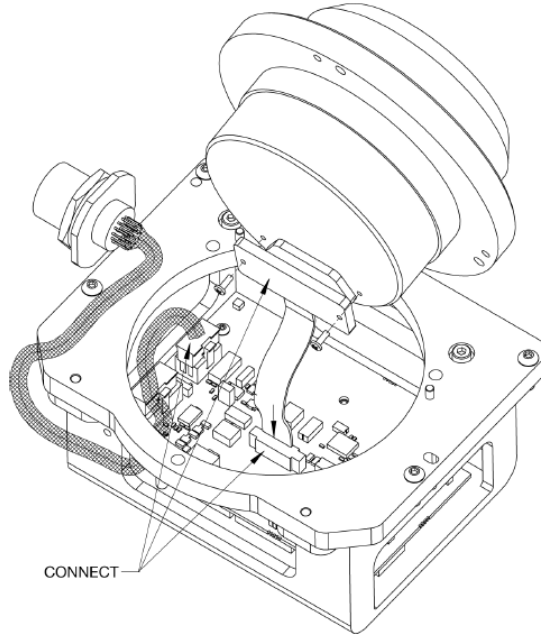

3. Being careful of the connectors and the orientation, align the pilot holes of the IMU with the pilot pins of the mounting plate. Gently place the IMU and mounting plate together, being careful not to pinch the cable harness. Screw the IMU and mounting plate together, using thread-locking fluid on the 8-32 screws, as shown in *Figure 114: Installing IMU to mounting plate* on the next page.

Figure 114: Installing IMU to mounting plate

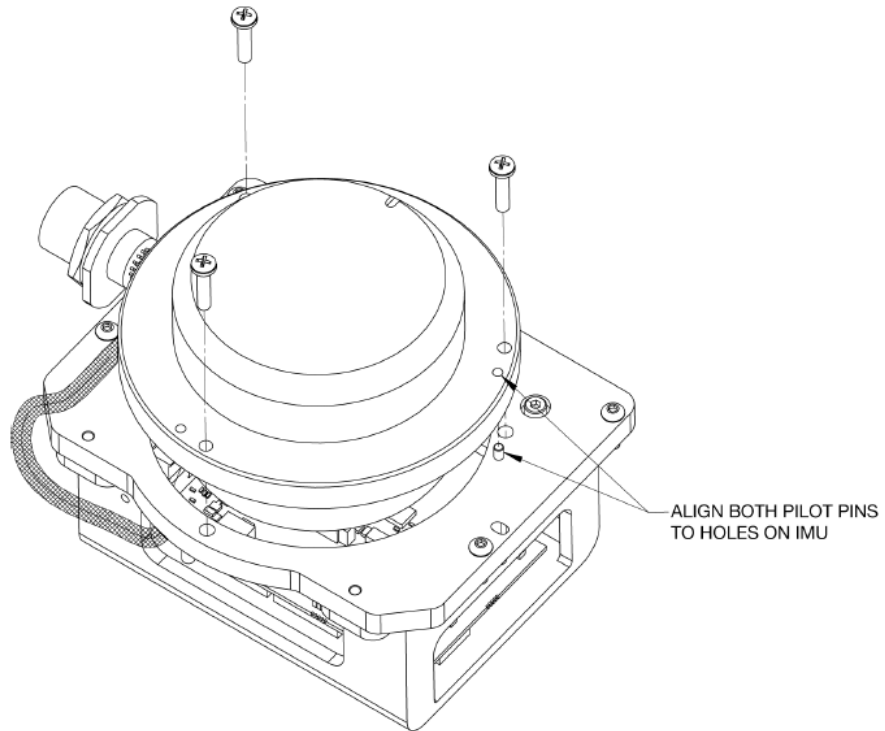

4. Starting with the round pilot hole, shown in *Figure 115: Assemble Into enclosure body* on the next page, align the pilot holes of the assembled plate (noting the orientation) with the pilot pins of the enclosure body. Lower the assembly into place, then fasten using thread-locking fluid on the M4 screws.

Figure 115: Assemble Into enclosure body

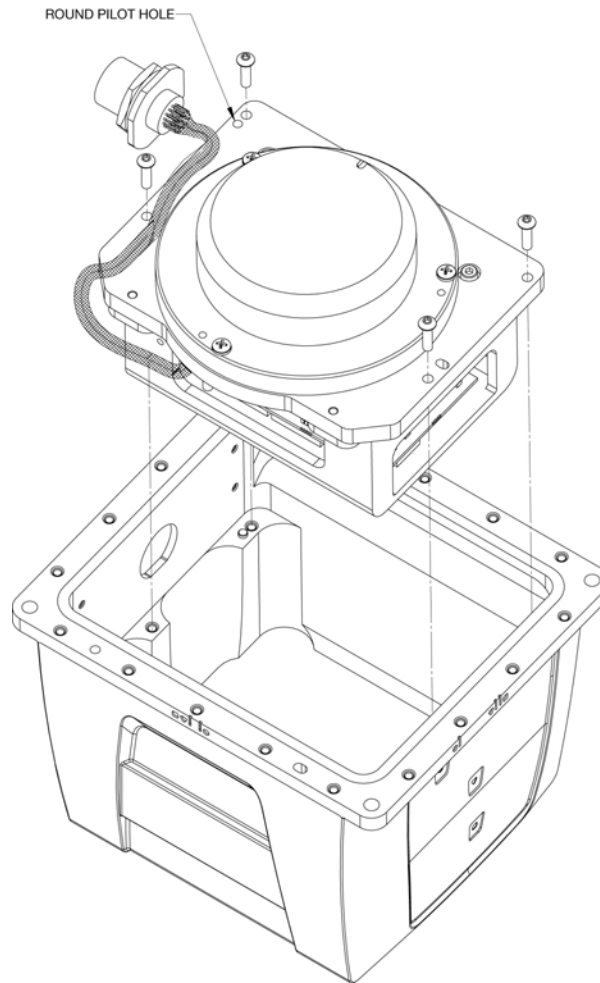

5. Connect the internal cable harness to the enclosure body, as shown in *Figure 116: Fasten internal cable harness* on the next page. During this step, ensure the connector O-ring (supplied with the connector of the internal cable harness) remains flat within the connector's groove, and make sure the groove is clean and free of debris. Fasten the connector to the enclosure body wall using the jam nut supplied with the connector. Apply thread-locking fluid then, with a 30 mm socket, tighten the jam nut to 6.9 N-m (61 lb-in/5.1 lb-ft).

Figure 116: Fasten internal cable harness

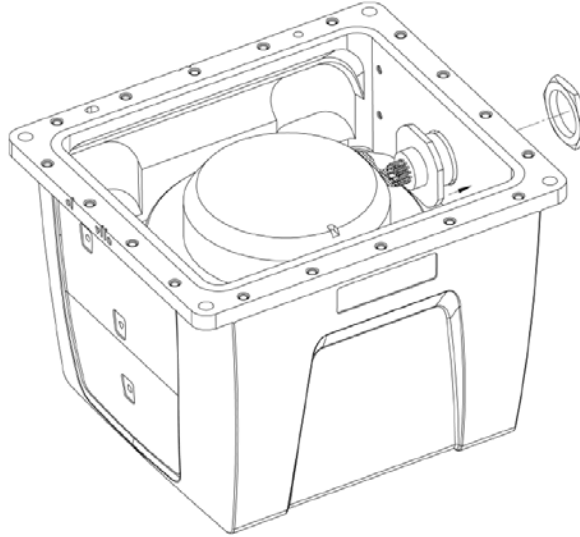

6. Ensure the O-rings are in place. If they are not, as necessary, make sure the grooves of the enclosure base are clean and free of debris, using isopropyl alcohol. As shown in *Figure 117: Install O-rings* below, install the outer environmental and inner EMI O-rings in the enclosure base, being careful not to stretch or twist them. O-rings must remain flat within the grooves during the remainder of the assembly procedure.

Figure 117: Install O-rings

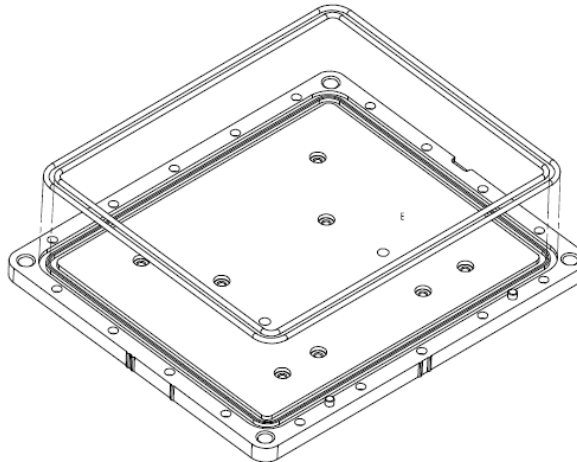

7. Clean the surface of the enclosure body, where it mates with the O-rings, using isopropyl alcohol. As shown in *Figure 118: Install enclosure body on the base* on the next page, align the reference markers and pilot holes/pins of the enclosure body and base. Carefully lower the body onto the base, observing the O-rings and alignment of corners. Press the enclosure body into place, starting with the round pilot hole indicated in *Figure 118: Install enclosure body on the base* on the next page.

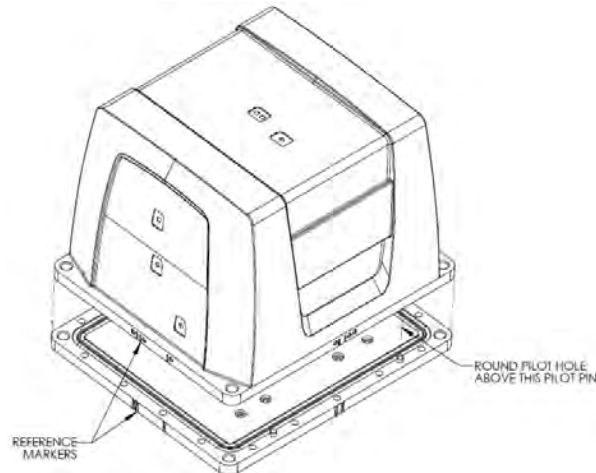
Figure 118: Install enclosure body on the base

8. While squeezing and holding the enclosure body and base together to maintain tight contact, carefully turn the assembly over and place it on its top, as shown in *Figure 119: Screw enclosure base to body* below. Using a 3 mm hex bit, lightly fasten four equally spaced M4 screws to hold the parts together. Apply thread-locking fluid to each screw before inserting. Install the remaining screws in similar fashion. Tighten all screws then check all of them again for tightness. Tighten these screws to 1.36-1.58 N-m (12-14 lb-in). Do not over-tighten.

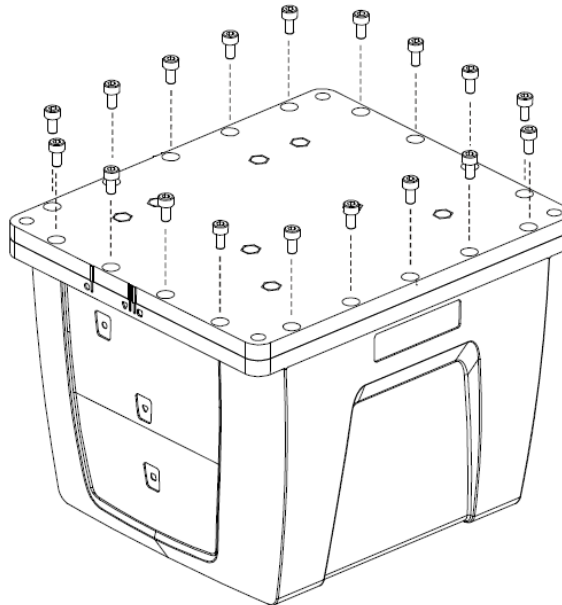
Figure 119: Screw enclosure base to body

9. Ensure the product identification label, the logo plate and the centre of navigation labels are properly affixed and contain the correct information. The final assembled unit will be similar to that shown in *Figure 120: Final assembly* on the next page.

Figure 120: Final assembly

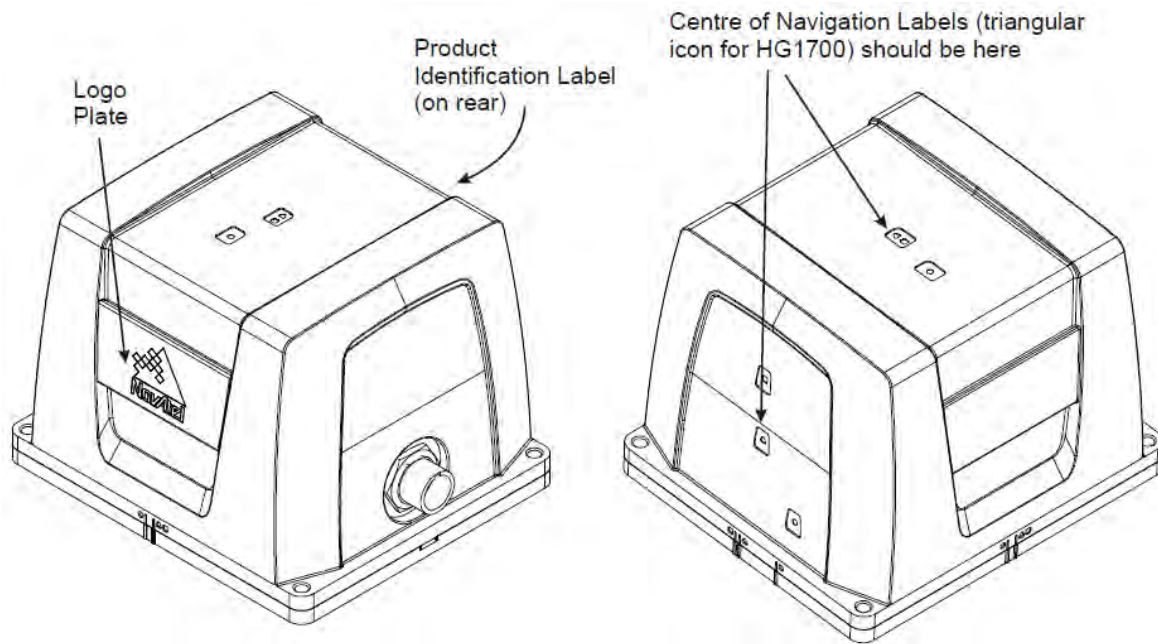

Appendix C LN-200 IMU in Universal enclosure



Important! Assemble in accordance with applicable industry standards. Ensure all ESD measures are in place, in particular, use a ground strap before exposing or handling any electronic items, including the IMU. Take care to prevent damaging or marring painted surfaces, O-rings, sealing surfaces, and the IMU.

The following procedure provides the necessary information to install the LN-200 sensor into the Universal Enclosure (NovAtel part number 01018590), both illustrated below. The steps required for this procedure are:

- Disassemble the Universal Enclosure
- Install the LN-200 Sensor Unit
- Reassemble the Universal Enclosure

Figure 121: Required parts

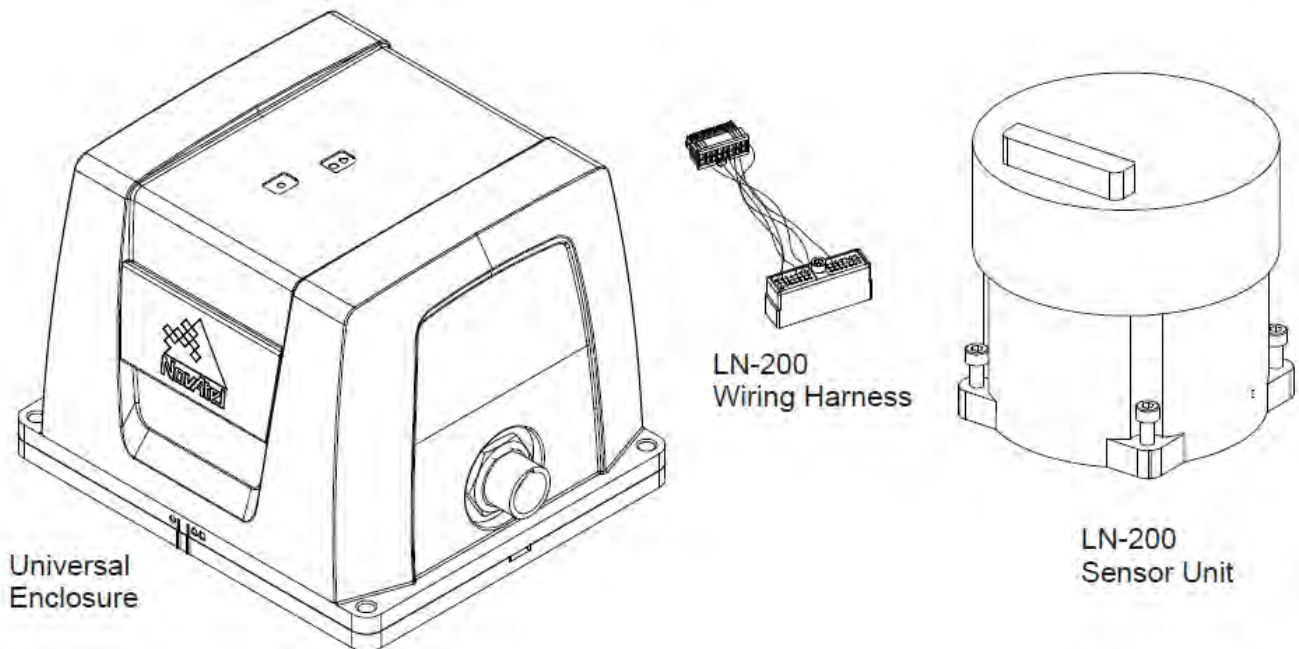

Use thread-locking fluid on all fasteners except for the cable harness connectors.



Torque values for all fasteners, including those for the cable harness screws, are as follows:

- Size 6-32: 0.79-0.90 N-m (7.0-8.0 lb-in)
- Size M4: 1.36-1.58 N-m (12.0-14.0 lb-in)

C.1 Disassemble the Universal enclosure

Disassemble the Universal Enclosure as follows:

1. Using a 3 mm hex bit, remove the M4 screws (they will be reused) and the base, as shown in *Figure 122: Remove base* below.

Figure 122: Remove base

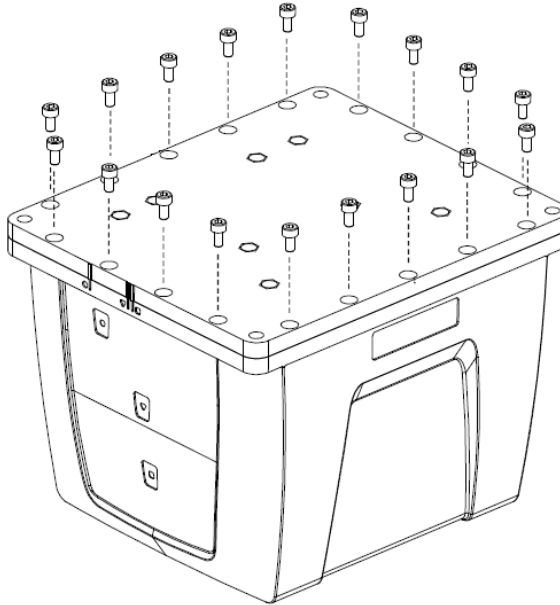

2. While squeezing and holding the assembly tightly together, carefully turn the assembly over and set it down as shown in *Figure 123: Disconnect wiring harness from SDLC card* below. Raise the enclosure body, and disconnect the internal cable harness at the SDLC board. Ensure the O-rings remain with the base when it is removed, and that they are not damaged.

Figure 123: Disconnect wiring harness from SDLC card

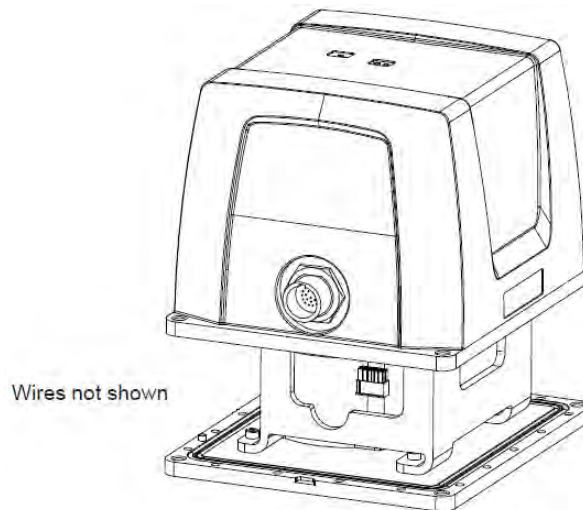

3. Lift the enclosure lid off the assembly to expose the IMU bracket, shown in *Figure 124: IMU bracket* on the next page. Disconnect the harness at the SDLC card and remove.

Figure 124: IMU bracket

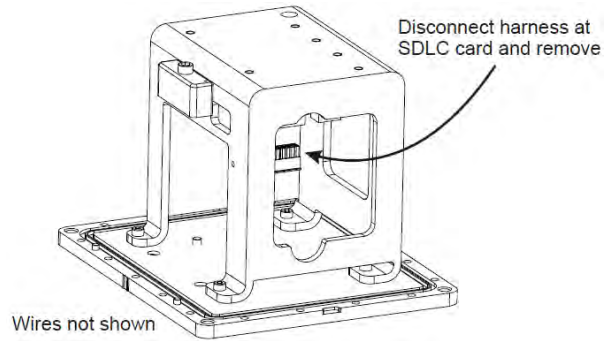

4. Using a 3 mm hex bit, unscrew 4 mm screws and remove the IMU bracket with SDLC, as shown in *Figure 125: Remove IMU bracket/SDLC below.*

Figure 125: Remove IMU bracket/SDLC

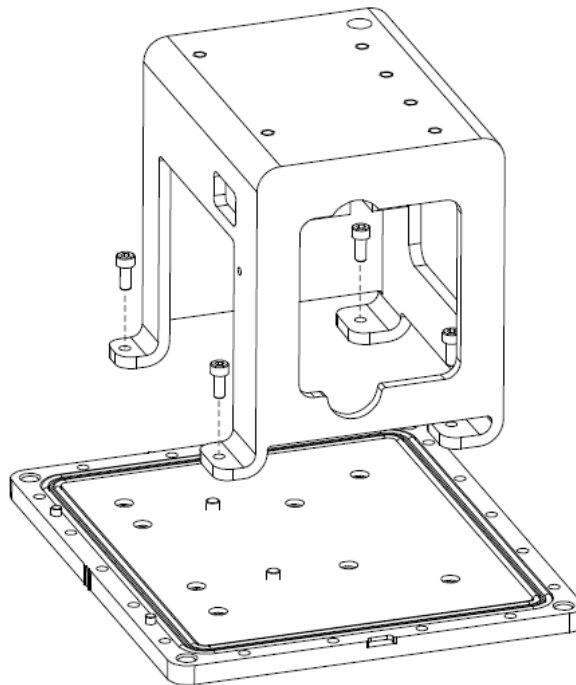

C.2 Install the LN-200 sensor unit

To install the LN-200 sensor unit in the Universal Enclosure:

1. Using a 3 mm hex bit, remove original captive 6-32 screws and washers (4 each) from the LN-200 IMU. Add three washers under each of the original washers and fasten the IMU to the enclosure base, as shown in *Figure 126: Install LN-200 IMU to base on the next page.* Use thread-locking fluid on each screw.

Figure 126: Install LN-200 IMU to base

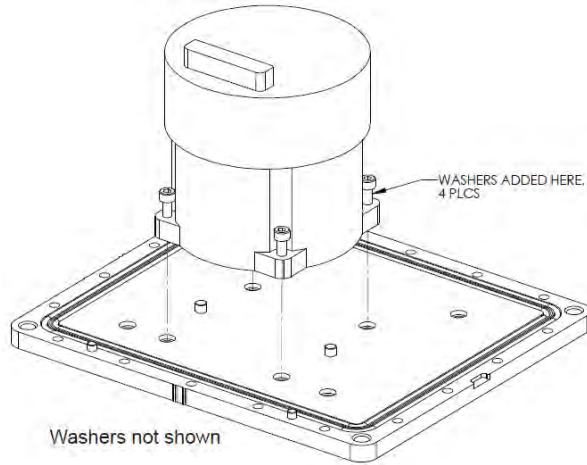

2. Using a long 3 mm hex bit, install the IMU bracket/SDLC to the base, as shown in *Figure 127: Install bracket to base* below. Use thread-locking fluid on each M4 screw.

Figure 127: Install bracket to base

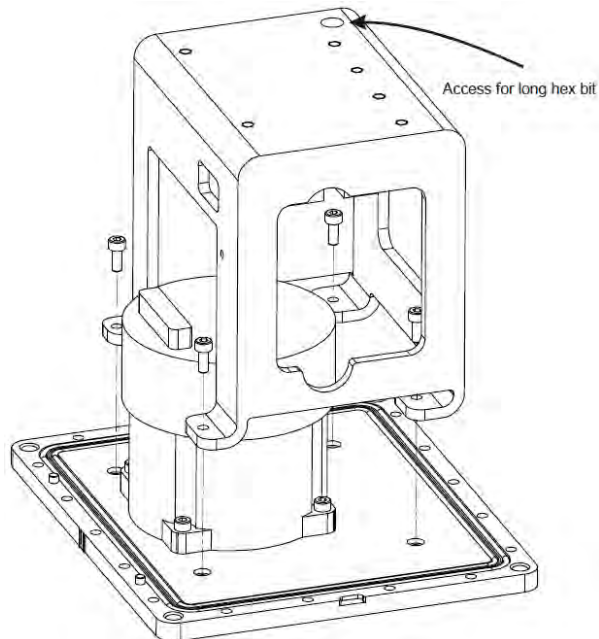

3. Connect the cable harness to the board assembly and IMU, routing it as shown in *Figure 128: Making connections* on the next page. Ensure latching of the cable connector housings and fasten the 6-32 screw at the IMU end using a 5/32" hex bit. Do not use thread-locking fluid and do not over tighten.

Figure 128: Making connections

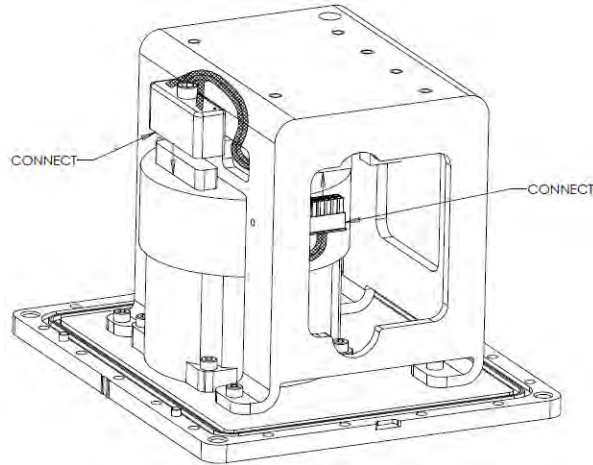

Make sure the tape of the harness is positioned for maximum protection.

4. While carefully holding the body over the bracket, connect the internal cable harness to the board assembly, as shown in *Figure 129: Connect internal cable harness* below.

Figure 129: Connect internal cable harness

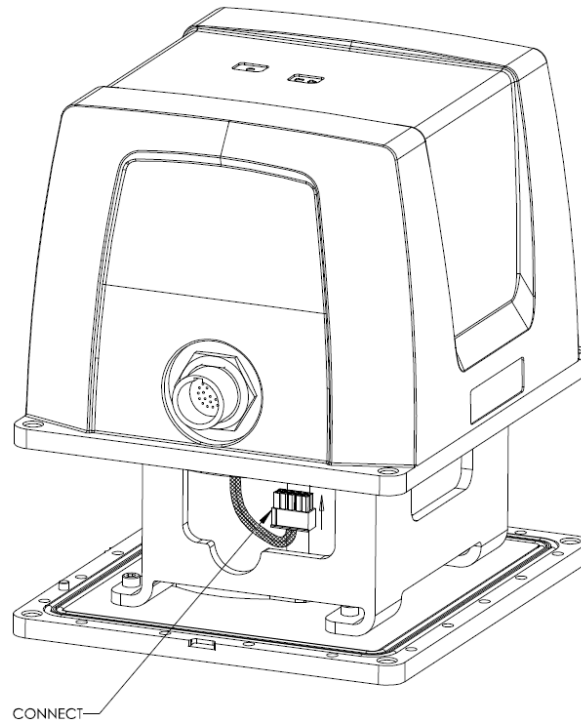

5. Clean the surface of the enclosure body, where it will mate with the O-rings, using isopropyl alcohol. While ensuring all wires will fit inside the bracket without being pinched, align the reference markers and pilot holes/screws of the enclosure body and base, and carefully lower the body onto the base, observing the O-rings and the alignment of corners. Start with the round pilot hole indicated in *Figure*

130: Installing the enclosure body to the base on the next page, then press the assembly into place.

Figure 130: Installing the enclosure body to the base

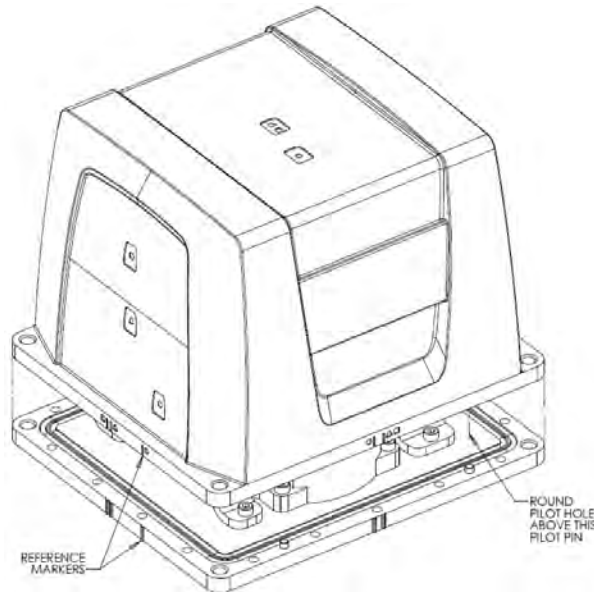

6. While squeezing and holding the enclosure body and base together to maintain tight contact, carefully turn the assembly over and place it on its top, as shown in *Figure 131: Screw enclosure base to body* below. Using a 3 mm hex bit, lightly fasten four equally spaced M4 screws to hold the parts together. Use thread-locking fluid on all screws. Install the remaining screws in similar fashion. Tighten all screws to 1.36-1.58 N-m (12-14 lb-in). Do not over-tighten.

Figure 131: Screw enclosure base to body

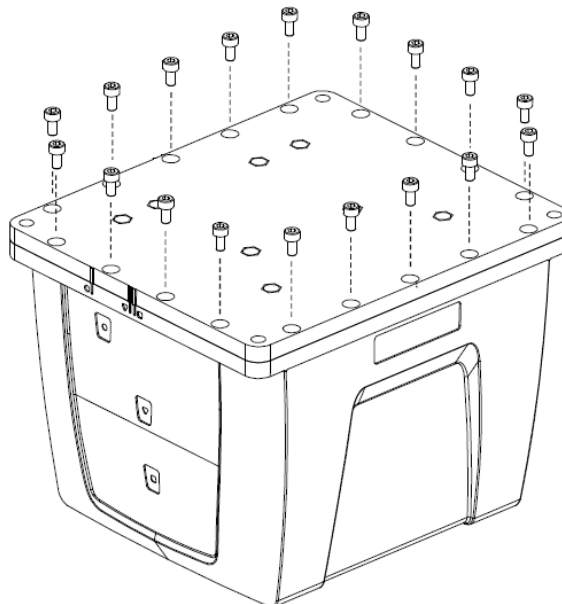

7. Ensure the product identification label, the logo plate and the centre of navigation labels are properly affixed and contain the correct information. The final assembled unit is shown in *Figure 132: Final assembly* on the next page.

Figure 132: Final assembly

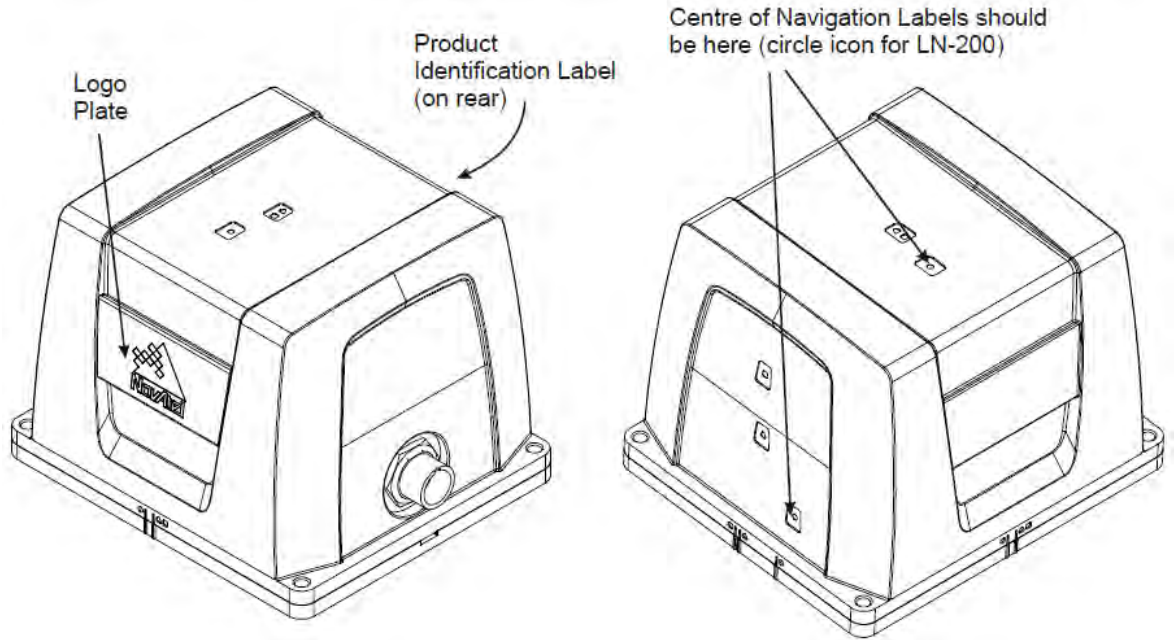

Appendix D HG1700 IMU in SPAN HG enclosure

The following procedure provides the necessary information to install the HG1700 sensor into the SPAN HG Enclosure (NovAtel part number 01017898). The steps required for this procedure are:

- Disassemble the SPAN HG Enclosure
- Install the HG1700 Sensor Unit
- Make Electrical Connections
- Reassemble the SPAN HG Enclosure



Ensure you use a ground strap before installing the internal circuit boards. Do NOT scratch any surfaces of the unit.

Figure 133: Required parts

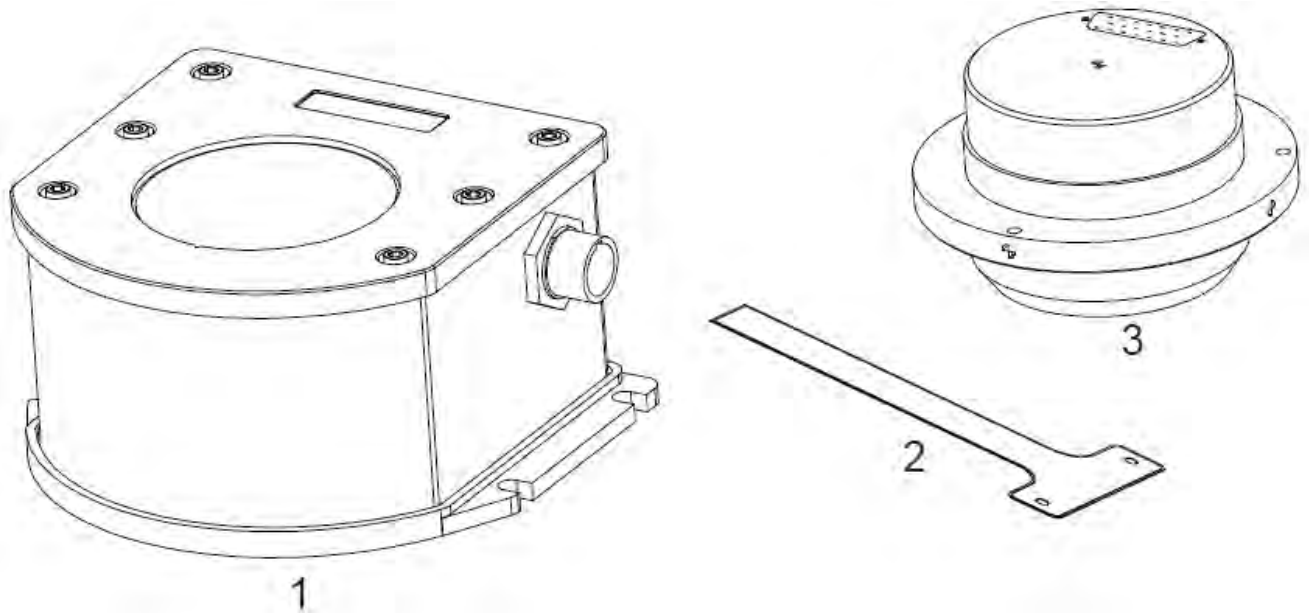

Reference	Description
1	SPAN IMU Enclosure
2	HG1700 Flex Cable
3	HG1700 Sensor Unit

D.1 Disassemble the SPAN IMU enclosure

The SPAN IMU assemblyman steps are as follows:

1. Remove the six bolts from the top cover using a hex key, as shown in *Figure 134: Bolts and hex key* on the next page:

Figure 134: Bolts and hex key

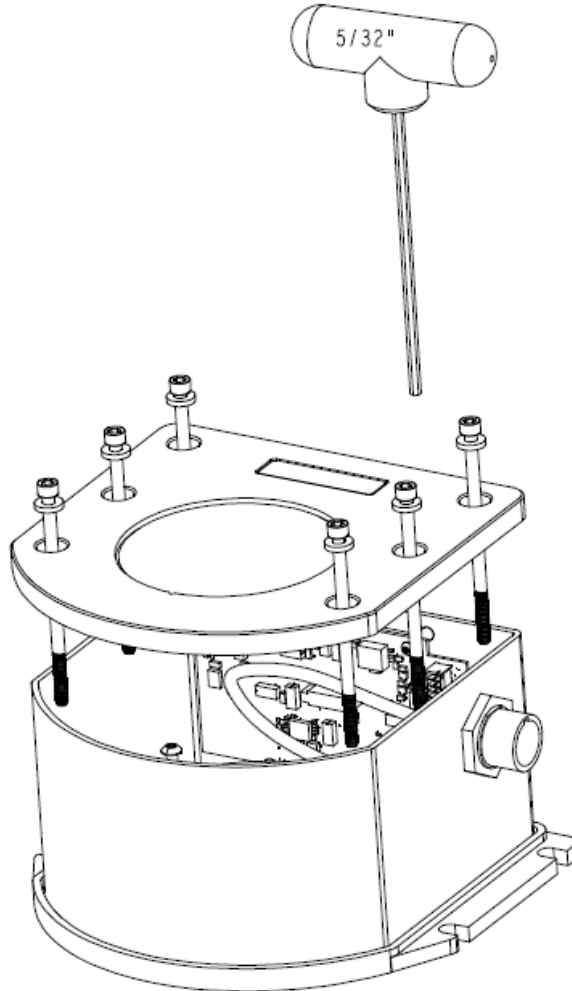

2. Set aside the bolts with their sealing washers.
3. Lift the top cover off the tube body and set it aside, as shown in *Figure 135: Lift top cover, tube body and 3 ring spacer screws* on the next page.
4. Lift the tube body away from its base plate and set it aside.
5. Remove the 3 ring spacer screws and set them aside.

Figure 135: Lift top cover, tube body and 3 ring spacer screws

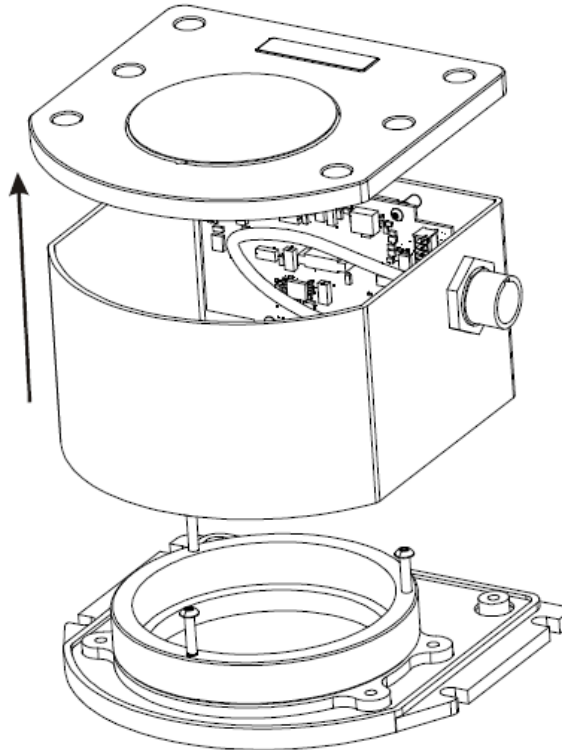

D.2 Install the HG1700 sensor unit

To re-assemble the SPAN IMU with the HG1700 sensor, see *Figure 136: SPAN IMU re-assembly* on the next page and follow these steps:

1. Mount the HG1700 sensor with the attached #8 screws. Apply threadlock to the screw threads. Use a hex key to torque each screw to 10 in-lbs.
2. Fit the tube body over the HG1700 sensor and onto the base plate.

Figure 136: SPAN IMU re-assembly

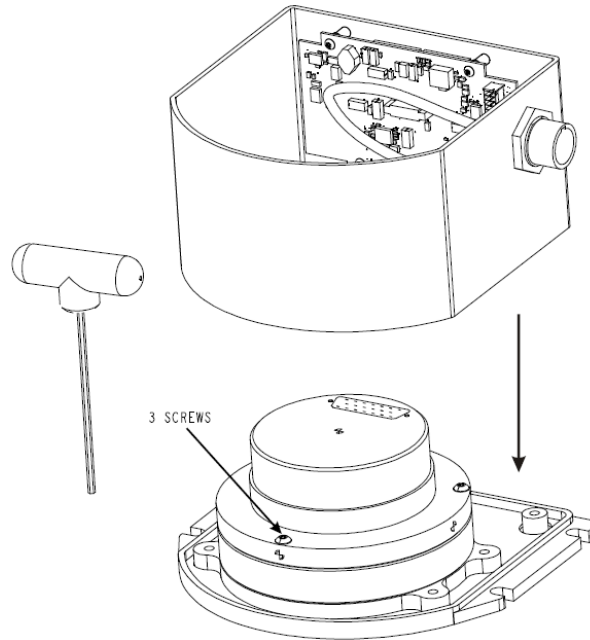

D.3 Make the electrical connections

To make the electrical connections you need a 3/32" hex key, the flex cable and the partially assembled SPAN IMU from *Install the HG1700 sensor unit* on the previous page. Now follow these steps:

1. Attach the flex cable to the HG1700 sensor ensuring that all the pins are fully connected. Check also that the pins are fully seated and that the flex cable stiffener around the pins is not bent upward, see *Figure 137: Attach flex cable* on the next page.

Figure 137: Attach flex cable

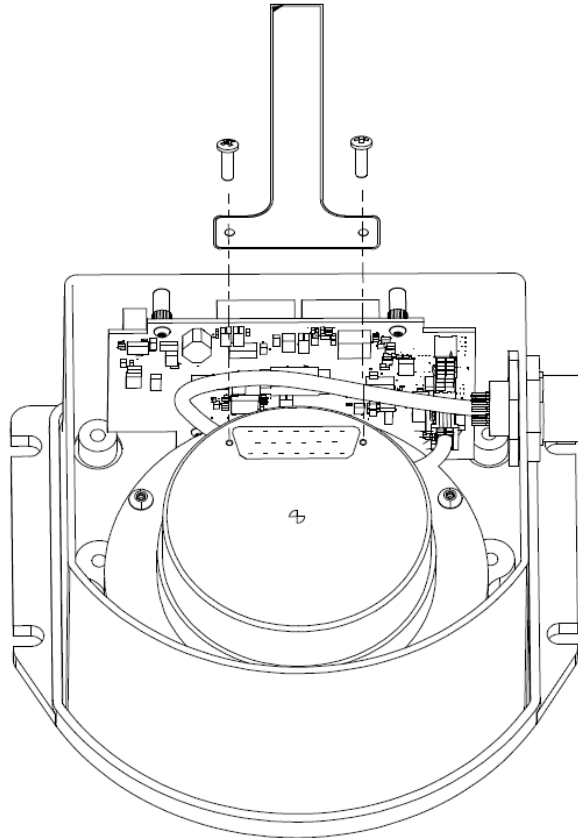

2. Tighten the screws to 4 in-lbs.
3. Connect the opposite end of the flex cable to the corresponding connector on the IMU card ensuring that the contacts on the flex cable mate with the contacts on the connector, as shown in *Figure 137: Attach flex cable* above.
4. Check that the flex cable is locked in place.

Figure 138: Incorrect (bowed) flex cable installation below shows an incorrect installation of the flex cable where it is bowed in the middle. It will not operate properly in this position. **Figure 139: Correct (flat) flex cable installation** below shows the proper installation of the flex cable. Notice how the flex cable sits flush against the IMU surface.

Figure 138: Incorrect (bowed) flex cable installation



Figure 139: Correct (flat) flex cable installation

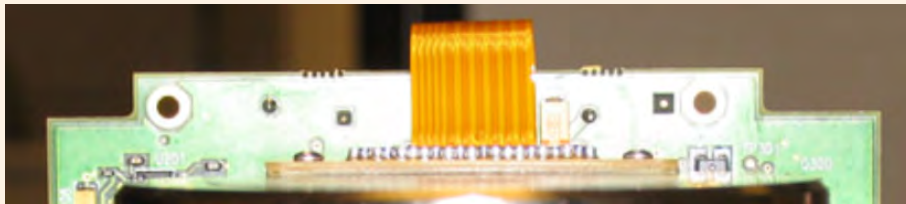

D.4 Re-Assemble the SPAN IMU enclosure

Use a hex key to align the long bolts with the threaded holes in the base, as shown in *Figure 134: Bolts and hex key* on page 319. Apply threadlock to threads. Finger tighten all bolts and torque them in a cross pattern to 12 in-lbs. The fully assembled IMU enclosure is shown in *Figure 140: HG1700 SPAN IMU* below.

Figure 140: HG1700 SPAN IMU

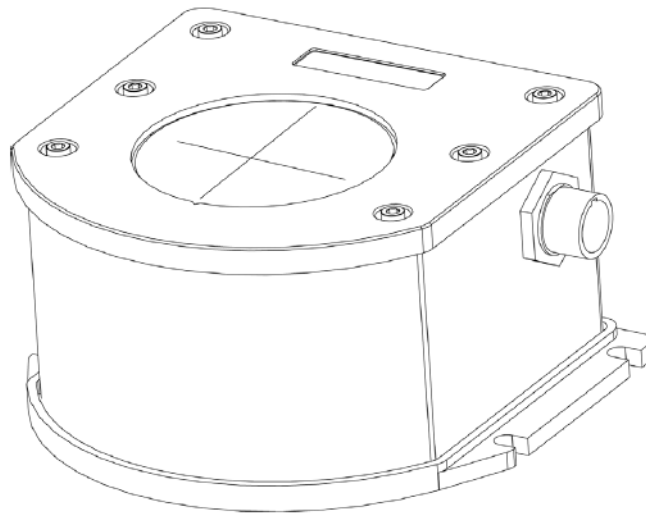

Appendix E LN-200 IMU in SPAN IMU enclosure

The following procedure provides the necessary information to install the LN-200 sensor (NovAtel part number 80023515) into the SPAN IMU enclosure (NovAtel part number 01017656) using the LN-200 wiring harness (NovAtel part number 01017655). The steps required for this procedure are:

- Disassemble the SPAN IMU Enclosure
- Install the LN-200 Sensor Unit
- Make Electrical Connections
- Reassemble the SPAN IMU Enclosure



Important! Ensure you use a ground strap before installing the internal circuit boards. Do NOT scratch any surfaces of the unit.

Figure 141: Required parts

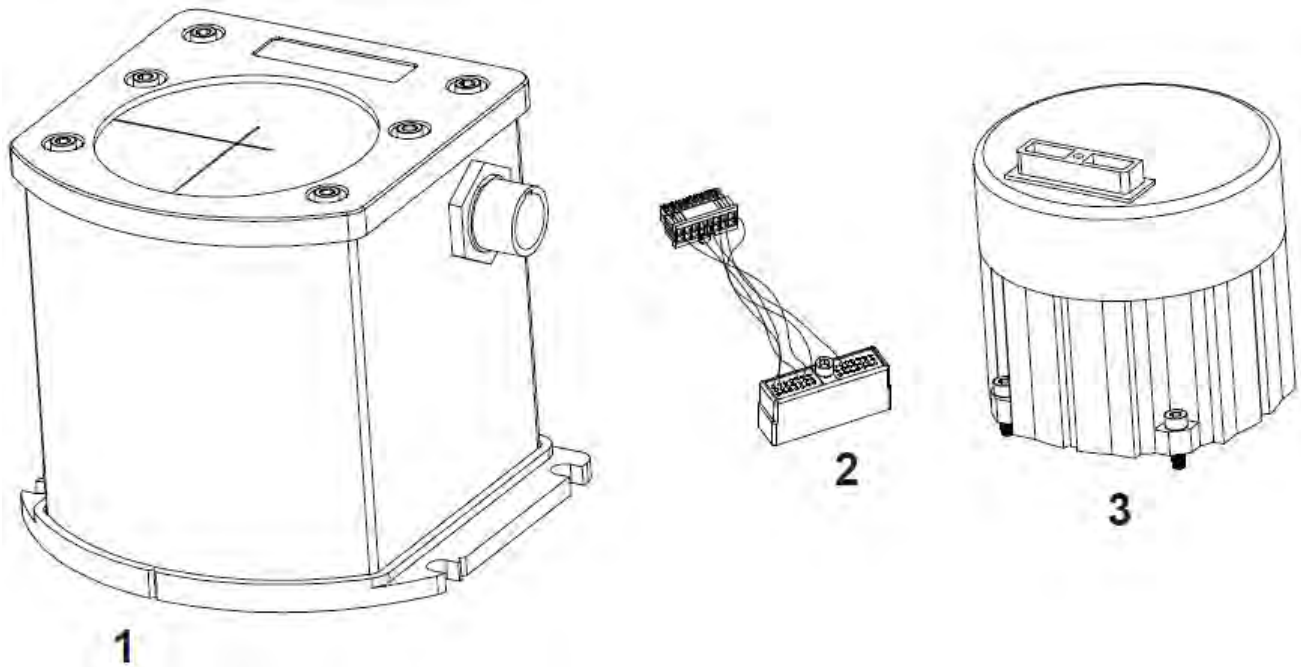

Reference	Description
1	SPAN IMU Enclosure
2	LN-200 Wiring Harness
3	LN-200 Sensor Unit

E.1 Disassemble the SPAN IMU enclosure

The SPAN IMU disassembly steps are as follows:

1. Remove the six bolts from the top cover using a hex key, as shown in *Figure 142: Bolts and hex key* below:

Figure 142: Bolts and hex key

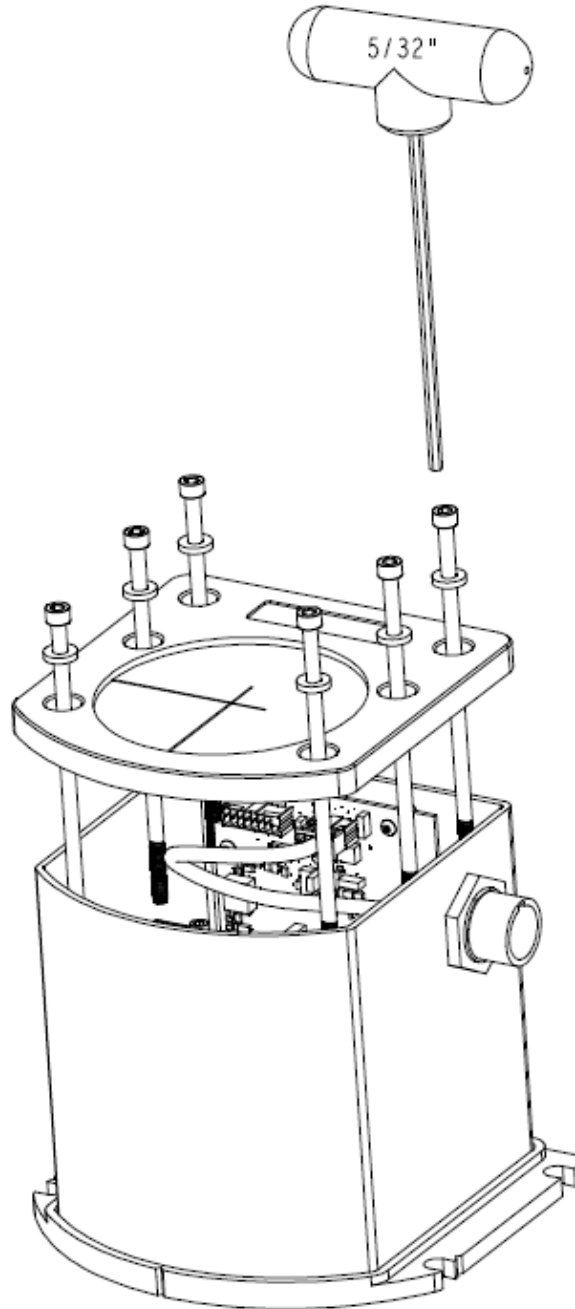

2. Set aside the bolts with their sealing washers.
3. Lift the top cover off the tube body and set it aside.
4. Lift the tube body away from its base plate and set it aside, as shown in *Figure 143: Lift top cover and tube body* on the next page.

Figure 143: Lift top cover and tube body

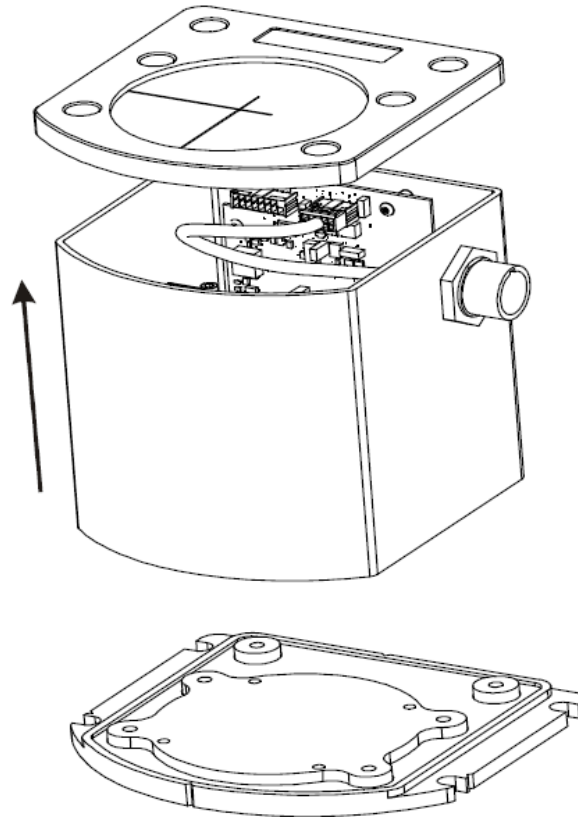

E.2 Install the LN-200 sensor unit

To install the LN-200 sensor, follow these steps:

1. Mount the LN-200 sensor with the attached M4 screws. Apply threadlock to the screw threads. Use a hex key to torque each screw to 10 in-lbs.
2. Fit the tube body over the LN-200 sensor and onto the base plate.

Figure 144: SPAN IMU re-assembly

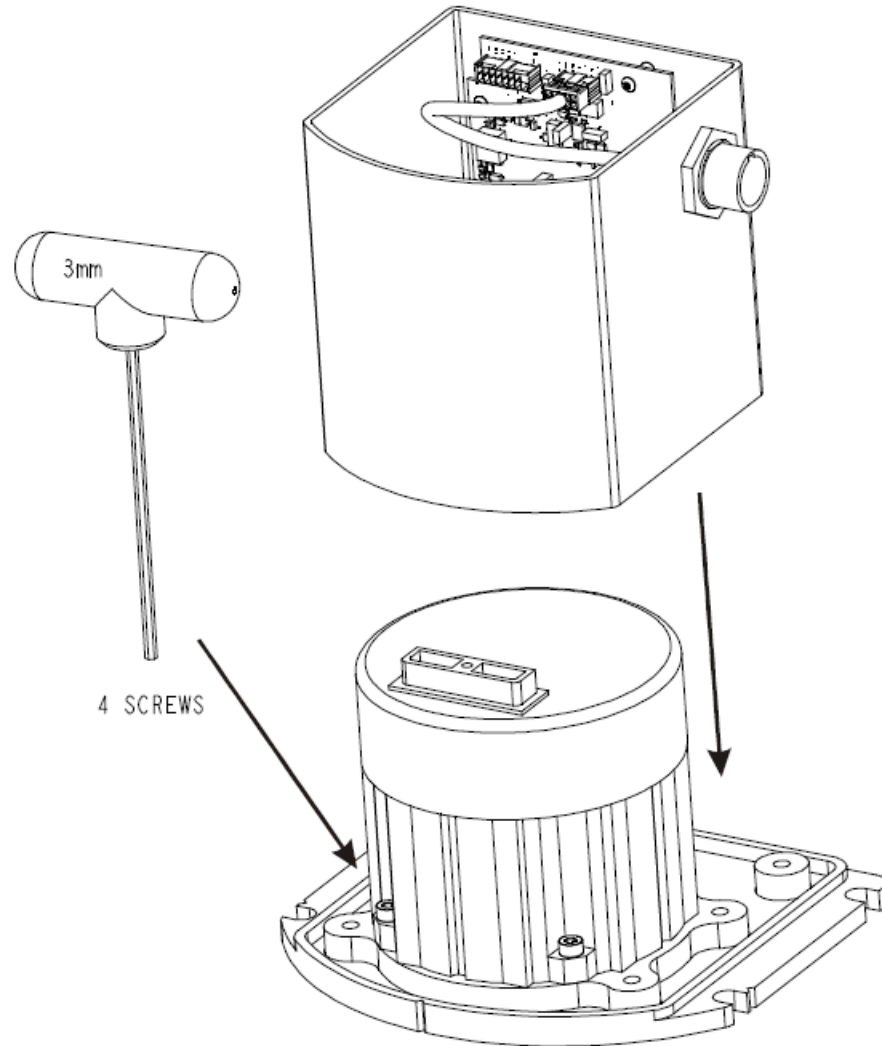

E.3 Make the electrical connections

To make the electrical connections you will need a 3/32" a hex key, the wiring harness and the partially assembled SPAN IMU from *Install the LN-200 sensor unit* on the previous page. Now follow these steps:

1. Attach the LN-200 wire harness to the mating connector on the LN-200. Check that the connector is fully seated, as shown in *Figure 145: Attach wiring harness* on the next page.

Figure 145: Attach wiring harness

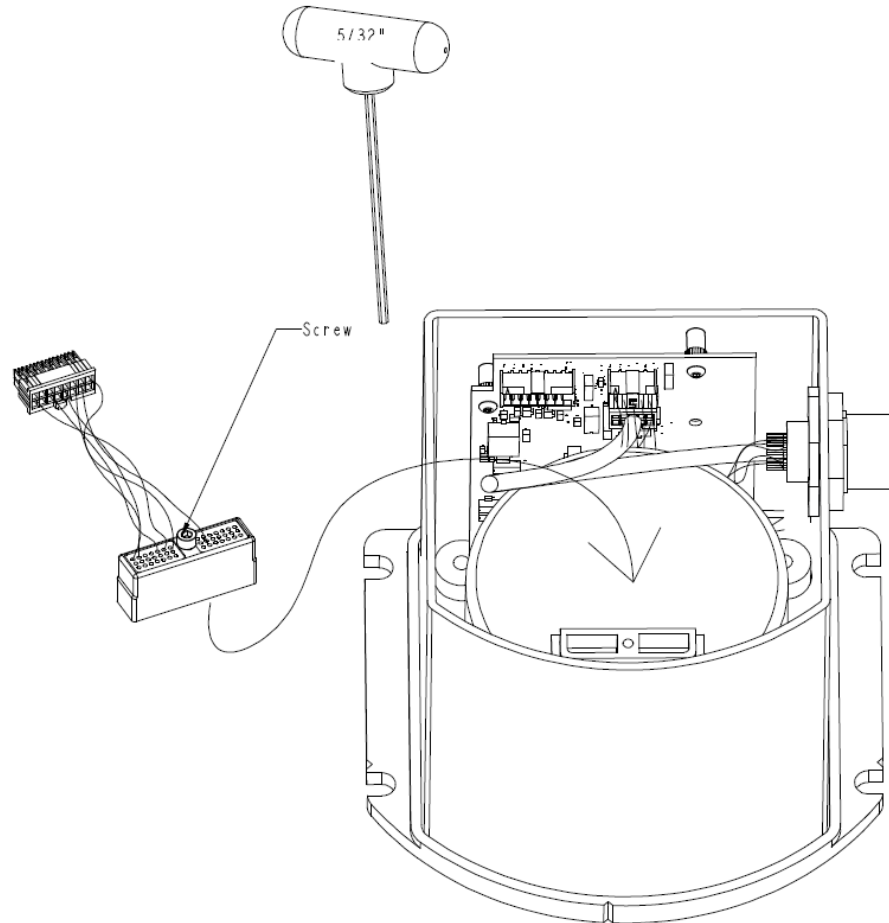

2. Connect the Samtec connector at the other end of the wiring harness to the corresponding connector on the internal IMU card, as shown in *Figure 146: Attach Samtec connector* on the next page. Ensure that the connector is locked in place.

Figure 146: Attach Samtec connector

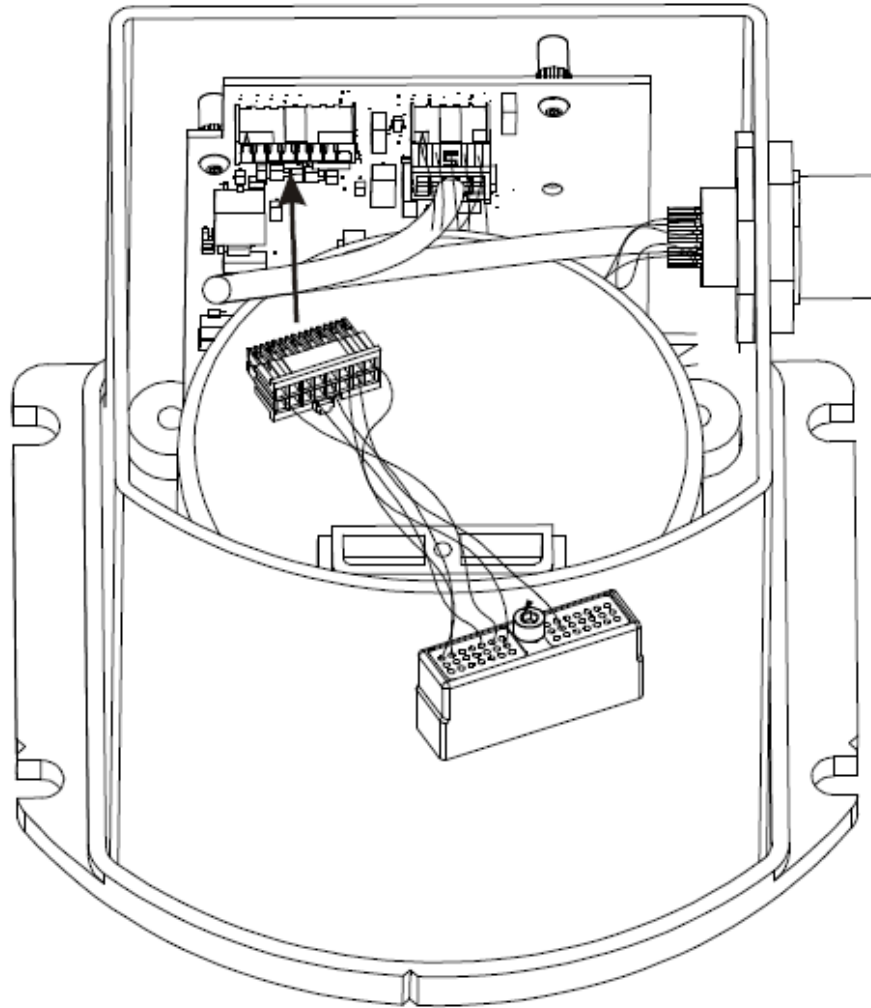

E.4 Re-Assemble the SPAN IMU enclosure

Use a hex key to align the long bolts with the threaded holes in the base, as shown in *Figure 142: Bolts and hex key* on page 325. Apply threadlock to threads. Finger tighten the 6 bolts then torque them in a cross pattern to 12 in-lbs. The fully assembled IMU enclosure is shown in *Figure 147: LN-200 SPAN IMU* on the next page.

Figure 147: LN-200 SPAN IMU

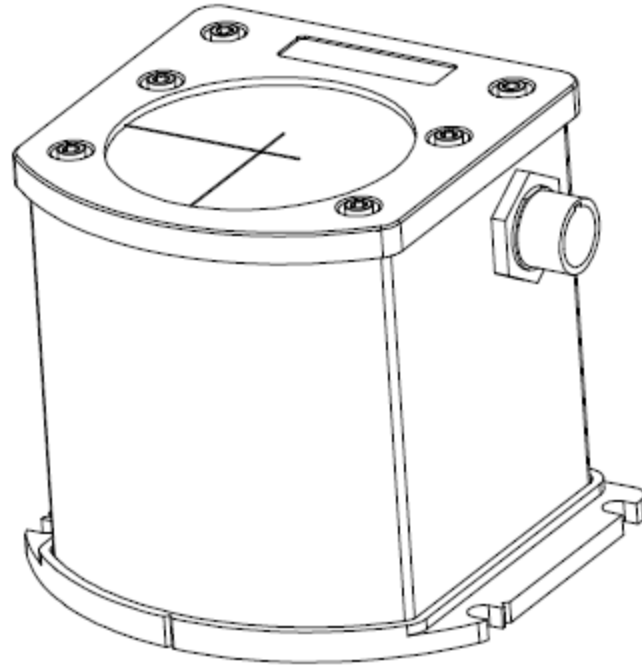

Appendix F Frequently asked questions

1. How do I know if my IMU is connected properly?
 - a. Refer to the **VERSION** log. If your IMU is communicating with a SPAN enabled receiver, the IMU details will be included in the log.
 - b. When powered, the HG-1700 IMU makes a noticeable humming sound. If no sound is heard, check that the cable between the receiver and IMU is connected properly.
 - c. Most IMUs do not make noise. Check that the IMU interface cable is properly connected to the receiver.
For the IMU-ISA-100C, IMU-FSAS, IMU-CPT, IMU-HG1900, IMU-LN200, IMU- μ IMU-IC, IMU-P1750 and IMU-KVH1750, ensure the IMU interface cable is connected to an RS-422 capable port and the port is configured to use RS-422.
 - d. If the cable is connected properly, check the flex cable mounted on top of the IMU. Refer to the instructions in this manual on proper IMU installation to ensure that the cable is seated properly on the IMU pins. See *HG1700 IMU in Universal Enclosure* on page 302 or *LN-200 IMU in Universal enclosure* on page 311 for more details.
 - e. Check the input power supply. A minimum of 12 V should be supplied to the system for stable IMU performance. The supply should also be able to output at least 12 W over the entire operating temperature range.
2. What is the minimum configuration I need to do to get the system running?
 - a. Set the IMU type and IMU communication port with the **CONNECTIMU** command.
 - b. Specify the translational offset between the IMU centre of navigation and the primary GNSS antenna phase centre with the **SETINSTRANSLATION** command.
 - c. Specify the rotational offset between the IMU Body frame and the Vehicle frame, with the **SETINSROTATION** command.
3. What types of IMUs are supported?

SPAN currently supports the following IMUs:

 - ADIS-16488 from Analog Devices
 - EG320N and EG370N from Epson
 - HG1700, HG1900, HG1930 and HG4930 from Honeywell
 - IMU-FSAS from iMar
 - KVH 1750, KVH P-1750 and IMU-CPT from KVH
 - ISA-100C and μ IMU from Northrop Grumman LITEF
 - LN-200 from Litton
 - STIM300 from Sensoror

Use the **CONNECTIMU** command to specify the type of IMU used.
4. Why don't I have any INS data?
 - a. By default, the raw IMU data begins flowing at system start up. If there is no INS data, check that the system has been configured properly.

- b. If the **INSCOMMAND** command has been set to **START_FINE_TIME**, the RAWIMU logs are not available until the system has solved for time. This requires that an antenna is attached and satellites are visible to the system. You can verify that time is solved by checking the time status in the header of any standard header log such as BESTPOS. When the time status reaches FINETIME, the inertial filter starts and IMU data is available.
5. How can I access the inertial solution?
- The GNSS+INS solution is available from a number of specific logs dedicated to the inertial filter. The **INSPOS** log, **INSPVA** log, **INSVEL** log, **INSSPD** log and **INSATT** log are the most commonly used logs for extracting the INS solution. These logs can be logged at any rate up to the rate of the IMU data (100, 125, 200 or 400 Hz depending on your IMU model). The solution can also be triggered by the mark input signal by requesting the **MARKxPVA** logs.
6. Can I still access the GNSS-only solution while running SPAN?
- The GNSS only solution used when running the OEM7 receiver without the IMU is still available when running SPAN. Logs such as the **PSRPOS** log and **RTKPOS** log are still available. The **BESTGNSSPOS** log is also available to provide the best available GNSS only solution. To manage processor load, any non-INS logs should be logged at a maximum rate of 5 Hz when running SPAN. Only INS-specific logs should be logged at rates higher than 5 Hz when running SPAN.
7. What will happen to the INS solution when I lose GNSS satellite visibility?
- When GNSS tracking is interrupted, the INS solution bridges through the gaps with what is referred to as free-inertial navigation. The IMU measurements are used to propagate the solution. Errors in the IMU measurements accumulate over time to degrade the solution accuracy. For example, after one minute of GNSS outage, the horizontal position accuracy is approximately 2.5 m when using an HG1700 AG58. The SPAN solution continues to be computed for as long as the GNSS outage lasts, but the solution uncertainty increases with time. This uncertainty can be monitored using the **INSSTDEV** log or **INSSTDEVS** log.
8. Why can SPAN not align with my IMU-KVH1750 or IMU-P1750?
- SPAN requires that the IMU-KVH1750 and IMU-P1750 be configured with non-default settings. If you have obtained your IMU-KVH1750 or IMU-P1750 directly from KVH, or have manually changed the IMU configuration, refer to *IMU-KVH1750 and IMU-P1750 baud rate conversion* on page 56 for information about configuring the IMU for operation with SPAN.



Further details on the command and logs in this section are available in the [OEM7 Commands and Logs Reference Manual](#).

Appendix G Importance of antenna selection

An antenna behaves both as a spatial and frequency filter, therefore, selecting the right GNSS antenna is critical for optimizing performance. An antenna must match the receiver's capabilities and specifications, as well as meet size, weight, environmental and mechanical specifications for the intended application.

Factors to consider when choosing a GNSS antenna include:

1. Constellation and signals

Each GNSS constellation and SBAS has its own signal frequencies and bandwidths. An antenna must cover the signal frequencies transmitted by the constellation and bandwidth supported by the GNSS receiver.

2. Antenna gain

Gain is a key performance indicator of a GNSS antenna. Gain can be defined as the relative measure of an antenna's ability to direct or concentrate radio frequency energy in a particular direction or pattern. A minimum gain is required to achieve a minimum carrier-to-power-noise ratio (C/No) to track GNSS satellites. The antenna gain is directly related to the overall C/No of the navigation GNSS receivers. Hence, antenna gain helps define the tracking ability of the system.

3. Element Gain

The element gain defines how efficient the antenna element is at receiving the signals. In any signal chain, you are only as good as the weakest link, so an antenna element with low element gain might be compensated by an increased low noise amplifier gain. However, the signal-to-noise ratio or C/No is still degraded.

4. Antenna beamwidth and gain roll-off

Gain roll-off is a factor of beamwidth, and specifies how much the gain changes over the elevation angle of the antenna. From the antenna's point of view, the satellites rise from the horizon towards zenith and fall back to the horizon. The variation in gain between zenith (directly overhead) and the horizon is known as the gain roll-off. Different antenna technologies have different gain roll-off characteristics.

5. Phase centre stability

The phase centre of the antenna is the point where the signals transmitted from satellites are collected. When a receiver reports a location fix, that location is essentially the phase centre of the antenna.

The electrical phase centre of any antenna will vary with the position of the transmitting signal it is receiving by as much as a few millimetres. As GNSS satellites move across the sky, the electrical phase centre of the signal received will typically move with the satellite position unless the antenna has been carefully designed to minimize Phase Centre Offset (PCO) and Phase Centre Variation (PCV).

The PCO with respect to the Antenna Reference Point (ARP) is the difference between the mechanical centre of antenna rotation and electrical phase centre location. The PCO is also frequency dependent which means that there can be a different offset for each signal frequency. The PCV identifies how much the phase centre moves with respect to the satellite elevation angles.

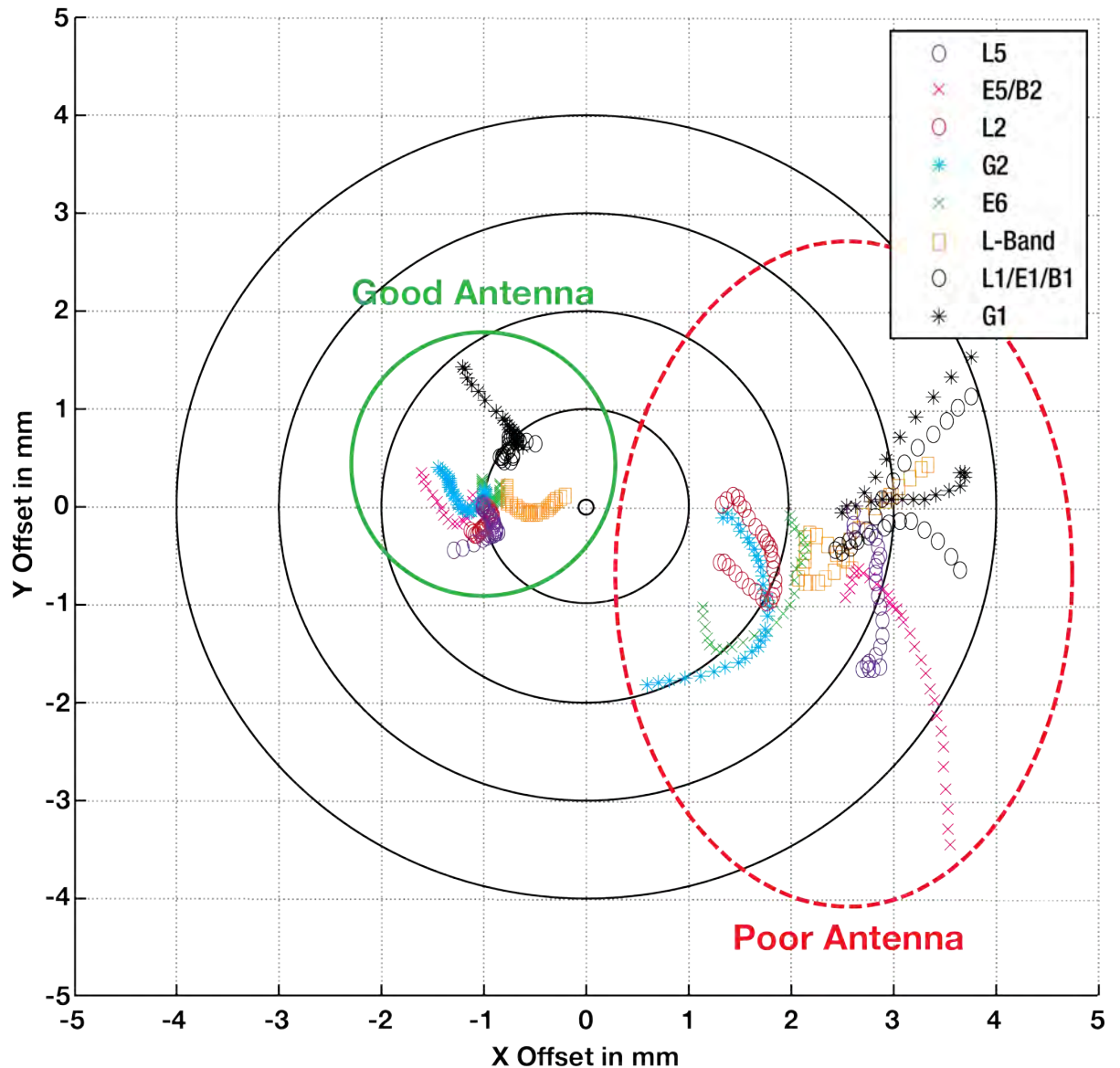
Figure 148: Plot of good and poor antenna phase centre variation over elevation angle 0-90°

Many users can accept accuracies of less than a metre so these small phase centre variations cause a negligible amount of position error. But if you require high precision, Real Time Kinematic (RTK) receivers can achieve position accuracies of 2-4 cm and a few millimetres of phase centre error translates to a 10-15% error in reported position. For RTK survey applications, geodetic grade antennas offer superior PCO/PCV performance.

6. The application

An antenna has to meet the performance, environmental, mechanical, and operational requirements of the intended application. For example, GNSS antennas used for aviation applications should ideally be TSO/FAA certified and be rugged enough to handle extreme temperatures and vibration profiles. Survey rover antennas should be able to survive rough handling by surveyors including a pole drop.

The table below highlights some of the important desirable features needed for a GNSS antenna based upon the user's application.

Desirable Feature	Survey	GIS	Reference Station	Aviation/Aerial Survey	Marine	Construction/Mining	Precision Agriculture	Vehicle Tracking	Dock Operations	Unmanned Aircraft	Unmanned Vehicle	Timing
Low Profile				•		•		•		•		
Ultra-low PCO/PCV	•		•									
Low PCO/PCV		•		•		•	•			•	•	
High Vibration				•		•	•		•	•	•	
Rugged	•	•	•			•			•			
Single Frequency												•
Multi Constellation	•	•	•	•	•	•	•		•	•	•	
Multi Frequency (RTK)	•	•	•		•	•	•		•	•	•	
L-band frequency (Correction Services)					•		•					
Narrow Bandwidth												•
Weatherproof	•	•	•	•	•	•	•	•	•	•	•	•
Corrosion Resistant			•		•	•			•			•
High Multipath Suppression	•		•		•	•	•		•		•	
Pole Mount	•	•	•		•	•			•			•
Magnetic/Surface Mount						•	•	•	•		•	
TSO/FAA Certification				•						•		
Extended Temperature Range			•	•						•		
Small Form-factor/ Lightweight		•								•		
High Altitude Operation			•	•						•		

Appendix H Accessories and replacement parts

The following tables list the replacement parts available for your NovAtel OEM7 receiver. For assistance or to order additional components, contact your local NovAtel dealer or Customer Support.

Table 175: OEM7 receivers

NovAtel part	Description
OEM719	OEM7 receiver card with OEM6 compatible 20 pin header
OEM729	OEM7 receiver card with OEM6 compatible 24 pin and 16 pin headers
OEM7600	OEM7 receiver card with high density 60 pin socket and small form factor
OEM7700	OEM7 receiver card with high density 60 pin socket
OEM7720	OEM7 receiver card with dual antenna inputs and high density 60 pin socket
PwrPak7	OEM7 enclosure with Wi-Fi and built in data storage
PwrPak7D	Dual antenna OEM7 enclosure with Wi-Fi and built-in data storage
PwrPak7-E1	Single enclosure SPAN GNSS+INS receiver with EG320N IMU, Wi-Fi and built-in data storage
PwrPak7D-E1	Single enclosure SPAN GNSS+INS receiver with dual antenna inputs, EG320N IMU, Wi-Fi and built-in data storage
PwrPak7-E2	Single enclosure SPAN GNSS+INS receiver with EG370N IMU, Wi-Fi and built-in data storage
PwrPak7D-E2	Single enclosure SPAN GNSS+INS receiver with dual antenna inputs, EG370N IMU, Wi-Fi and built-in data storage
PwrPak7M	OEM7 enclosure (no Wi-Fi or data storage)
PwrPak7DM	Dual antenna OEM7 enclosure (no Wi-Fi or data storage)
PwrPak7M-E1	Single enclosure SPAN GNSS+INS receiver with an EG320N IMU (no Wi-Fi or data storage)
PwrPak7DM-E1	Single enclosure SPAN GNSS+INS receiver with dual antenna inputs and EG320N IMU (no Wi-Fi or data storage)
PwrPak7M-E2	Single enclosure SPAN GNSS+INS receiver with an EG370N IMU (no Wi-Fi or data storage)
PwrPak7DM-E2	Single enclosure SPAN GNSS+INS receiver with dual antenna inputs and EG370N IMU (no Wi-Fi or data storage)
PwrPak7Q-E2	Single enclosure SPAN GNSS+INS receiver with EG370N IMU and built-in data storage (no Wi-Fi)
PwrPak7DQ-E2	Single enclosure SPAN GNSS+INS receiver with dual antenna inputs, EG370N IMU and built-in data storage (no Wi-Fi)
CPT7	Single enclosure SPAN GNSS+INS receiver with dual antenna inputs, HG4930 IMU and built-in data storage
CPT7700	Single enclosure SPAN GNSS+INS receiver with HG4930 IMU and built-in data storage

Table 176: SPAN compatible IMUs

NovAtel part	Description
IMU-CPT	KVH CPT IMU
IMU-FSAS-EI	IMAR IMU-FSAS IMU
IMU-HG1900	Honeywell HG1900-CA50 IMU in an IMU enclosure
IMU-H58	Honeywell HG1700-AG58 IMU in a SPAN HG IMU Enclosure
IMU-H62	Honeywell HG1700-AG62 IMU in a SPAN HG IMU Enclosure
IMU-IGM-A1	Analog Devices ADIS-16488 IMU in an IMU-IGM enclosure
IMU-IGM-S1	Sensoror STIM300 IMU in an IMU-IGM enclosure
IMU-ISA-100C	Litef ISA-100C IMU in an Universal IMU Enclosure
IMU-KVH1750	KVH 1750 IMU
IMU-LN200	Northrop Grumman LN-200-L IMU in an IMU enclosure
IMU-P1750	KVH P-1750 IMU
IMU- μ IMU-IC	Litef μ IMU-IC IMU in an IMU enclosure
OEM-IMU-ADIS-16488	Analog Devices ADIS16488 IMU
OEM-IMU-EG320N	Epson G320N IMU
OEM-IMU-EG370N	Epson G370N IMU
OEM-HG1900	Honeywell HG1900-CA50 IMU
OEM-H1930-CA50	Honeywell HG1930-CA50 IMU
OEM-IMU-HG4930-AN01	Honeywell HG4930 AN01 IMU
OEM-IMU-HG4930-AN04	Honeywell HG4930 AN04 IMU
OEM-IMU-ISA-100C	Litef ISA-100C IMU
OEM-IMU-LN200	Northrop Grumman LN-200-L IMU
OEM-IMU-STIM300	Sensoror STIM300 IMU
OEM-IMU- μ IMU-IC	Litef μ IMU-IC IMU
OEM-IMU- μ IMU-IC-UART	Litef μ IMU-IC IMU with an RS-422 interface
UIMU-HG1700-AG58	Honeywell HG1700_AG58 IMU in a Universal IMU Enclosure
UIMU-HG1700-AG62	Honeywell HG1700_AG62 IMU in a Universal IMU Enclosure
UIMU-LN200	Northrop Grumman LN-200-L IMU in a Universal IMU enclosure
IMU Interface Cards	
OEM-IMU-ADIS-MIC OEM-IMU-STIM-MIC	MEMS Interface Card (MIC) for MEMS IMUs
OEM-IMU-ISA-UIC	Universal IMU Controller (UIC) for OEM-IMU-ISA-100C

Table 177: GNSS antennas

NovAtel part	Description
High performance antennas	
GNSS 502	GPS L1/L2, GLONASS L1/L2, BeiDou B1/B2b, Galileo E1/E5b, QZSS L1/L2, L-band
GNSS-503	GPS L1/L2/L5, GLONASS L1/L2, BeiDou B1/B2a/B2b, Galileo E1/E5a/E5b/E6, QZSS L1/L2/L5, NavIC L5, L-band
GNSS-802	GPS L1/L2, GLONASS L1/L2, BeiDou B1, Galileo E1, QZSS L1/L2
GNSS-802L	GPS L1/L2, GLONASS L1/L2, BeiDou B1, Galileo E1, QZSS L1/L2, L-band
GNSS-804	GPS L1/L2, GLONASS L1/L2, BeiDou B1/B2I/B2b, Galileo E1/E5b, QZSS L1/L2
GNSS-804L	GPS L1/L2, GLONASS L1/L2, BeiDou B1/B2I/B2b, Galileo E1/E5b, QZSS L1/L2, L-band
GNSS-850	GPS L1/L2/L5, GLONASS L1/L2/L3, BeiDou B1/B2I/B2a/B2b/B3, Galileo E1/E5a/E5b/E6, QZSS L1/L2/L5/L6, NavIC L5, L-band
Compact antennas	
2G15A-XTB-1	2.6" circular form factor (GPS L1)
3G15A-XT-1	3.5" circular form factor (GPS L1)
3GNSSA-XT-1	3.5" circular form factor (GPS L1/L2/L5, GLONASS L1/L2, BeiDou B1/B2a/B2b, Galileo E1/E5a/E5b, QZSS L1/L2/L3, NavIC L5, L-band)
42G1215A-XT-1	ARINC-743 bolt pattern (GPS L1/L2)
42GNSSA-XT-1	ARINC-743 bolt pattern (GPS L1/L2/L5, GLONASS L1/L2, BeiDou B1/B2a/B2b, Galileo E1/E5a/E5b, QZSS L1/L2/L3, NavIC L5, L-band)
G3Ant-2A196MNS-4	2.7" circular form factor (GPS L1, GLONASS L1, BeiDou B1, Galileo E1 and L-band)
G3Ant-42A4T1	ARINC-743 bolt pattern (GPS L1, GLONASS L1, BeiDou B1, Galileo E1, L-band)
G3Ant-4AT1	Mini-ARINC pattern (GPS L1, GLONASS L1, Galileo E1, BeiDou B1, L-band)
G5Ant-3AMT1	3.5" circular form factor (GPS L1/L2, GLONASS L1/I2, BeiDou B1/B2a, Galileo E1/E5a, L-band)
G5Ant-3AT1	3.5" circular form factor (GPS L1/L2, GLONASS L1/I2, BeiDou B1, Galileo E1, L-band)
G5Ant-42AT1	ARINC-743 bolt pattern (GPS L1/L2, GLONASS L1/L2, BeiDou B1, Galileo E1, L-band)
G5Ant-42AT1-A	ARINC-743 bolt pattern (GPS L1/L2, GLONASS L1/I2, BeiDou B1/B2a, Galileo E1/E5a, L-band)

Table 178: IMU interface cables

NovAtel part	Description
01018388	IMU-FSAS IMU with Wheel Sensor Interface cable
01018966	IMU-CPT IMU interface cable
01018977	Universal IMU Enclosure Interface cable
01019007	OEM-IMU-ADIS-16488 IMU Cable Kit
01019013	IMU-IGM Stack Up Cable
01019015	SPAN-IGM Auxiliary Port Interface Cable
01019016	IMU-IGM Interface Cable
01019040	SPAN-IGM/IMU-IGM Bracket Kit
01019174	OEM-IMU-STIM300 Cable
01019211	IMU-KVH1750 and IMU-P1750 Interface Cable
01019319	IMU Enclosure Interface Cable
01019393	UIC to OEM-IMU-ISA-100C Interface Cable
01019760	UIC to OEM-IMU- μ IMU-IC Interface Cable
01019762	UIC to OEM-HG1900 Interface Cable
01019763	UIC to LN200 Interface Cable
60723136	IMU Enclosure Power Cable
60723137	IMU Enclosure Wheel Data Cable

Table 179: GNSS antenna cables

NovAtel part	Description
GPS-C006	5 metres – TNC to TNC cable
GPS-C016	15 metres – TNC to TNC cable
GPS-C032	30 metres – TNC to TNC cable
60723177	2.5 metres – SMA to TNC cable
60723178	5 metres – SMA to TNC cable

