



HEXAGON



**OEM7
Installation and Operation
User Manual**

OEM7 Installation and Operation User Manual

Publication Number: OM-20000168

Revision Level: v18

Revision Date: April 2022

Firmware Version:

- 7.08.10 / OM7MR0810RN0000: OEM719, OEM729, OEM7700
- 7.08.00 / OM7MR0800RN0000: OEM7600, OEM7720

To download the latest firmware and/or software visit: novatel.com/support/support-materials/firmware-download.

Warranty

NovAtel Inc. warrants that its GNSS products are free from defects in materials and workmanship, subject to the conditions set forth on our web site: novatel.com/products/novatel-warranty-and-return-policies.

Return Instructions

To return products, refer to the instructions found at: novatel.com/products/novatel-warranty-and-return-policies.

Proprietary Notice

ALIGN, GLIDE, NovAtel, NovAtel CORRECT, OEM6, OEM7, PwrPak7, RTK ASSIST, SPAN, STEADYLINE and TerraStar are trademarks of NovAtel, Inc., entities within the Hexagon Autonomy & Positioning division, their affiliated entities, and/or their licensors. All other trademarks are properties of their respective owners.

©2022 NovAtel Inc. All rights reserved. NovAtel is part of Hexagon. NovAtel makes no representation or warranty regarding the accuracy of the information in this publication. This document gives only a general description of the product(s) or service(s) offered by NovAtel and, except where expressly provided otherwise, shall not form part of any contract. Such information, the products and conditions of supply are subject to change without notice.

Table of Contents

Figures

Tables

Receiver Card Notices

Customer Support

Chapter 1 Introduction

1.1 OEM7 Receiver Card Overview	21
1.1.1 OEM7 Family Card	21
1.1.2 Enclosure	22
1.1.3 GNSS Antenna	22
1.1.4 Power Supply	22
1.1.5 Optional External Frequency Reference	22
1.1.6 Data Communications Equipment	22
1.1.7 OEM719 Receiver Overview	23
1.1.8 OEM729 Receiver Overview	24
1.1.9 OEM7600 Receiver Overview	25
1.1.10 OEM7700 Receiver Overview	26
1.1.11 OEM7720 Receiver Overview	27
1.2 Related Documents and Information	28

Chapter 2 OEM7 Family Receiver Cards Installation

2.1 Additional Equipment Required	29
2.2 Selecting a GNSS Antenna	29
2.3 Choosing a Coaxial Cable	30
2.4 Power Supply Requirements for Receiver Cards	30
2.5 Card Installation Overview	31
2.5.1 Electrostatic Discharge (ESD) Precautions	31
2.6 Mounting the Printed Circuit Board	31
2.6.1 Planning the Mount Location	32
2.6.2 Board to Board Spacing	32
2.6.3 Mounting Options	33
2.6.4 Mounting the OEM7600	37
2.6.5 Thermal Dissipation	38
2.6.6 OEM7720 Accessory Heat Spreader	38
2.6.7 Vibration	39
2.7 Preparing the Data, Signal and Power Interface	39
2.8 Mounting the GNSS Antenna	45
2.9 Connecting the Antenna to the Receiver Card	46
2.9.1 Antenna LNA Power	47
2.10 Applying Power to the Receiver Card	47
2.11 Connecting Data Communications Equipment	47

2.11.1	Serial Ports	47
2.11.2	USB Ports	51
2.11.3	Ethernet Ports	52
2.11.4	SPI Ports	53
2.12	Check that the Receiver is Operating	53

Chapter 3 OEM7 Receiver Operation

3.1	Communications with the Receiver	55
3.1.1	USB Communications	56
3.1.2	Serial Port Communications	56
3.1.3	Ethernet Communications	58
3.1.4	ICOM Communications	59
3.1.5	CAN Bus Communications	59
3.2	Getting Started	59
3.2.1	Communicating with the Receiver	60
3.3	Transmitting and Receiving Corrections	60
3.3.1	Defining Antenna and Base Antenna	62
3.3.2	Base Station Configuration	62
3.3.3	Rover Station Configuration	63
3.3.4	Configuration Notes	64
3.4	ALIGN Heading Master and Remote Configurations	64
3.4.1	Automatic Set Up for Direct-Wire Connection between Master and Rover via COM2	65
3.4.2	Manual Set Up via COM2	65
3.5	GLIDE	65
3.5.1	Dual-Frequency GLIDE	66
3.5.2	PDP and GLIDE Configurations	66
3.6	STEADYLINE	66
3.6.1	Prefer Accuracy	67
3.7	Enabling SBAS Positioning	67
3.8	Enabling PPP	68
3.8.1	TerraStar Subscriptions	68
3.8.2	Veripos Subscriptions	70
3.9	RTK ASSIST	70
3.10	Transferring Time Between Receivers	71
3.10.1	GPS to Receiver Time Synchronization	71
3.10.2	Time Definitions	71
3.10.3	Procedures to Transfer Time	72
3.11	Interference Toolkit	76
3.11.1	Monitoring GNSS Signals	76
3.11.2	Disable/Enable Detection	78
3.11.3	Monitoring Signals Using a Command Line	78
3.11.4	Monitoring Signals Using NovAtel Application Suite	79
3.11.5	Remove Interference Signals	79
3.11.6	Interference Toolkit Commands and Logs	80
3.12	Logging and Retrieving Data Overview	81
3.12.1	Pass-Through Logging	81
3.12.2	Saving Logs to a File	81

3.12.3 Logging Using NovAtel Application Suite or Setup & Monitor (Web)	82
3.13 Additional Features and Information	83
3.13.1 Strobes	83
3.13.2 Status Indicator	83
3.13.3 External Oscillator	83

Chapter 4 Built-In Status Tests

4.1 Receiver Status Word	85
4.2 Error Strobe Signal	85
4.3 RXSTATUSEVENT Log	86
4.4 RXSTATUS Log	86
4.4.1 Status Word	86
4.4.2 Error Word	87
4.4.3 Status Code Arrays	87
4.4.4 Receiver Status Code	88
4.4.5 Auxiliary Status Codes	88
4.4.6 Set and Clear Mask for all Status Code Arrays	88
4.5 Status LED	88

Chapter 5 Ethernet Configuration

5.1 Required Hardware	90
5.2 Static IP Address Configuration	90
5.2.1 Static IP Address Configuration—Receiver	91
5.2.2 Static IP Address Configuration—Windows 7	92
5.2.3 Confirming Ethernet Setup	92
5.3 Dynamic IP Address Configuration	93
5.4 Base/Rover Configuration through Ethernet Connectivity	94
5.5 Large Ethernet Port Data Throughput	95

Chapter 6 NTRIP Configuration

6.1 NTRIP Configuration Over Ethernet	96
---------------------------------------	----

Chapter 7 CAN Bus

7.1 Default Configuration	99
7.2 Configuring the CAN Bus	99
7.2.1 Configuration Notes	99
7.2.2 Example of Enabling the CAN Bus	100
7.2.3 Example of Modifying the CAN Bus Parameters	100
7.2.4 Example of Detecting an Address Claim Failure and Reconfiguring	100
7.2.5 Address Claim Procedure	101
7.3 NMEA2000 Logging	101
7.3.1 Example of NMEA2000 Log Configuration	102
7.4 Corrections Over CAN	102
7.4.1 Example for Receiving Corrections from Any Source	102
7.4.2 Example for Transmitting Corrections to 0x1C Node	102
7.5 NovAtel Messages Over CAN	102

7.6	Configuring OEM7 Receivers to Use OEM6 CAN Settings	103
7.6.1	Configuration on OEM6	103
7.6.2	Configuration on OEM7	103

Chapter 8 Troubleshooting

8.1	Examining the RXSTATUS Log	106
8.2	Examining the AUX1 Status Word	109
8.3	High Temperature Environments	110
8.3.1	Indicators of an Error State	110
8.3.2	Recovering from a Temperature Status Error	111
8.3.3	Mitigating High Receiver Temperature	111
8.3.4	Monitoring the Receiver Temperature	111
8.4	Safe Mode	112
8.4.1	Reset Loop Detection	112
8.4.2	Recovery Steps	112

Chapter 9 NovAtel Firmware

9.1	Firmware Updates and Model Upgrades	114
9.1.1	Firmware Updates	114
9.1.2	Model Upgrades	114
9.2	Authorization Code	114
9.3	Downloading Firmware Files	115
9.3.1	Format of Firmware Files	115
9.4	Updating or Upgrading Using the WinLoad Utility	116
9.4.1	Open a File to Download	116
9.4.2	Communications Settings	117
9.4.3	Downloading Firmware	118
9.5	Updating the Firmware Using NovAtel Application Suite	118
9.6	Updating the Firmware Using Setup & Monitor (Web)	119
9.7	Updating Using SoftLoad Commands	119
9.7.1	Implementing SoftLoad	119
9.7.2	Use SoftLoad Customer Support utilities	120
9.7.3	Self-Implement the SoftLoad process	125
9.8	Update Setup & Monitor (Web)	131
9.8.1	Update Setup & Monitor (Web) Content Using NovAtel Application Suite	131
9.8.2	Update Setup & Monitor (Web) Content Using Setup & Monitor (Web)	131
9.9	Upgrading Using an Auth-Code	132
9.9.1	Entering an Auth-Code Using NovAtel Application Suite	132
9.9.2	Entering an Auth-Code Using Setup & Monitor (Web)	132
9.9.3	Entering an Auth-Code Using the Command Line	133

APPENDIX A OEM719 Technical Specifications

A.1	OEM719 Performance Specifications	135
A.2	OEM719 Mechanical Specifications	137
A.3	OEM719 Electrical and Environmental Specifications	144
A.4	OEM719 Data Communication Specifications	146

A.5 OEM719 Strobe Specifications	148
A.6 OEM719 Interface Connector	150
A.6.1 P1701 Main Connector 20-Pin Header	150

APPENDIX B OEM729 Technical Specifications

B.1 OEM729 Performance Specifications	155
B.2 OEM729 Mechanical Specifications	157
B.3 OEM729 Electrical and Environmental Specifications	160
B.4 OEM729 Data Communication Specifications	163
B.5 OEM729 Strobe Specifications	165
B.6 OEM729 Interface Connectors	167
B.6.1 P1802 Main Connector 24-Pin Header	167
B.6.2 P1803 Expansion Connector 16-Pin Header	171

APPENDIX C OEM7600 Technical Specifications

C.1 OEM7600 Performance Specifications	175
C.2 OEM7600 Mechanical Specifications	177
C.3 OEM7600 Electrical and Environmental Specifications	179
C.4 OEM7600 Data Communication Specifications	181
C.5 OEM7600 Strobe Specifications	183
C.6 OEM7600 Interface Connector	185
C.6.1 P2001 Main Connector 60-Pin Socket	185

APPENDIX D OEM7700 Technical Specifications

D.1 OEM7700 Performance Specifications	196
D.2 OEM7700 Mechanical Specifications	198
D.3 OEM7700 Electrical and Environmental Specifications	201
D.4 OEM7700 Data Communication Specifications	203
D.5 OEM7700 Strobe Specifications	205
D.6 OEM7700 Interface Connector	207
D.6.1 P2001 Main Connector 60-Pin Socket	207

APPENDIX E OEM7720 Technical Specifications

E.1 OEM7720 Performance Specifications	218
E.2 OEM7720 Mechanical Specifications	221
E.3 OEM7720 Electrical and Environmental Specifications	224
E.4 OEM7720 Data Communication Specifications	226
E.5 OEM7720 Strobe Specifications	228
E.6 OEM7720 Interface Connector	230
E.6.1 P1901 Main Connector 60-Pin Socket	230

APPENDIX F Receiver Card Interface Examples

F.1 EVENT_IN, EVENT_OUT and PPS Signal Protection	241
F.2 Position Valid (PV) LED Driver	243

F.3 Communication Ports	244
F.4 CAN Controller Ports	245
F.5 USB Interface	246
F.6 Ethernet Port	249

APPENDIX G Importance of Antenna Selection

APPENDIX H Accessories and Replacement Parts

H.1 Manufacturers' Part Numbers	256
H.1 USB Devices Supported	257
H.1.1 Restrictions on connecting mass storage devices	258

APPENDIX I Electrostatic Discharge (ESD) Practices

I.1 Handling ESD Sensitive Devices	259
I.2 Prime Static Accumulators	259
I.3 Handling Printed Circuit Boards	260

Figures

Figure 1: OEM7 Receiver System	21
Figure 2: OEM719 Receiver Board	23
Figure 3: OEM729 Receiver Board	24
Figure 4: OEM7600 Receiver Board	25
Figure 5: OEM7700 Receiver Board	26
Figure 6: OEM7720 Receiver Board	27
Figure 7: Mounting with Standoffs	34
Figure 8: Mounting with Rails	34
Figure 9: Mounting with Rails and Clamping Bars	34
Figure 10: Mounting the High-Density, 60 Pin Connector	36
Figure 11: Mounting the OEM7600	37
Figure 12: OEM7720 Heat Spreader Mounting Geometry	39
Figure 13: OEM719 Connector and Indicator Locations	41
Figure 14: OEM729 Connector and Indicator Locations	42
Figure 15: OEM7600 Connector and Indicator Locations	43
Figure 16: OEM7700 Connector and Indicator Locations	44
Figure 17: OEM7720 Connector and Indicator Locations	45
Figure 18: COM3 and USB Multiplexed on OEM719	49
Figure 19: OEM729 COM3 Multiplexed with EVENT2 and USERGPIO	50
Figure 20: COM5 Multiplexed with COM2 Flow Control	51
Figure 21: Basic OEM7 Receiver Connection Interfaces (example)	55
Figure 22: Basic Differential Setup	61
Figure 23: Positioning Change Without STEADYLINE	67
Figure 24: STEADYLINE Prefer Accuracy	67
Figure 25: Transfer COARSE Time from Fine Clock to Cold Clock Receiver	73
Figure 26: Transfer FINE Time from Fine Clock to Cold Clock Receiver	74
Figure 27: Transfer FINE Time from Fine Clock to Warm Clock Receiver	75
Figure 28: 1 PPS Alignment	75
Figure 29: Location of Receiver Status Word	86
Figure 30: Reading the Bits in the Receiver Status Word	86
Figure 31: Location of Receiver Error Word	87
Figure 32: Reading the Bits in the Receiver Error Word	87
Figure 33: Status Code Arrays	88
Figure 34: Status LED Flash Sequence Example	89
Figure 35: Cross-Over Ethernet Cable Configuration—OEM7 Receiver	91

Figure 36: Dynamic IP Address Configuration through a DHCP Server—OEM7 Receiver	93
Figure 37: Base/Rover Ethernet Setup—OEM7 Receiver	94
Figure 38: NTRIP System	96
Figure 39: WinLoad's Open Window	116
Figure 40: Open File in WinLoad	117
Figure 41: COM Port Setup	117
Figure 42: OEM719 Dimensions	137
Figure 43: OEM719 Keep-outs	138
Figure 44: OEM719A Dimensions	139
Figure 45: OEM719A Keep-outs	140
Figure 46: OEM719B Dimensions	141
Figure 47: OEM719B Keep-outs	142
Figure 48: OEM719 Mounting Surface	143
Figure 49: OEM729 Dimensions	157
Figure 50: OEM729 Keep-outs	158
Figure 51: OEM729 Mounting Surfaces	159
Figure 52: OEM7600 Dimensions	177
Figure 53: OEM7600 Interface Board Details	178
Figure 54: OEM7700 Dimensions	198
Figure 55: OEM7700 Keep-outs	199
Figure 56: OEM7700 Mounting Surfaces	200
Figure 57: OEM7720 Dimensions	221
Figure 58: OEM7720 Keep-outs	222
Figure 59: OEM7720 Mounting Surfaces	223
Figure 60: Protection and Buffering for EVENT_IN, PPS and EVENT_OUT signals	241
Figure 61: OEM7 Buffer for Driving High-Brightness LEDs from PV	243
Figure 62: OEM7 CAN Transceiver Example	245
Figure 63: OEM7 USB Device Interface Example	246
Figure 64: OEM7 USB Host Device Interface Example	247
Figure 65: Ethernet Reference Schematic	249
Figure 66: Plot of Good and Poor Antenna Phase Center Variation over Elevation Angle 0-90°	252

Tables

Table 1: NovAtel Mounting Rails	36
Table 2: OEM7 Communication and I/O Connectors	40
Table 3: OEM7 Antenna Connectors	46
Table 4: OEM7 Card Default Serial Port Configurations	47
Table 5: Available USB Ports	51
Table 6: USB Port Mode	52
Table 7: Serial Ports Supported	57
Table 8: Default NAME	99
Table 9: Troubleshooting Based on Symptoms	105
Table 10: Resolving a Receiver Error Word	107
Table 11: Resolving an Error in the Receiver Status Word	108
Table 12: Resolving an Error in the AUX1 Status Word	109
Table 13: OEM719 Physical Description	134
Table 14: OEM719 Receiver Performance	135
Table 15: OEM719 Environmental Specifications	144
Table 16: OEM719 Power Requirements	144
Table 17: OEM719 RF Input/LNA Power Output	144
Table 18: OEM719 Data Communication Interfaces	146
Table 19: OEM719 Strobe Description	148
Table 20: OEM719 Strobe Electrical Specification	149
Table 21: OEM729 Physical Description	154
Table 22: OEM729 Receiver Performance	155
Table 23: OEM729 Environmental Specifications	160
Table 24: OEM729 Power Requirements	160
Table 25: OEM729 RF Input/LNA Power Output	160
Table 26: OEM729 External Oscillator Input	161
Table 27: Data Communications Interface	163
Table 28: OEM729 Strobes Description	165
Table 29: OEM729 Strobe Electrical Specifications	166
Table 30: OEM7600 Physical Description	174
Table 31: OEM7600 Receiver Performance	175
Table 32: OEM7600 Environmental Specifications	179
Table 33: OEM7600 Power Requirements	179
Table 34: OEM7600 RF Input/LNA Power Output	179
Table 35: Data Communications Interface	181

Table 36: OEM7600 Strobes Description	183
Table 37: OEM7600 Strobe Electrical Specifications	184
Table 38: OEM7700 Physical Description	195
Table 39: OEM7700 Receiver Performance	196
Table 40: OEM7700 Environmental Specifications	201
Table 41: OEM7700 Power Requirements	201
Table 42: OEM7700 RF Input/LNA Power Output	201
Table 43: Data Communications Interface	203
Table 44: OEM7700 Strobes Description	205
Table 45: OEM7700 Strobe Electrical Specifications	206
Table 46: OEM7720 Physical Description	217
Table 47: OEM7720 Receiver Performance	218
Table 48: OEM7720 Environmental Specifications	224
Table 49: OEM7720 Power Requirements	224
Table 50: OEM7720 RF Input/LNA Power Output	224
Table 51: Data Communications Interface	226
Table 52: OEM7720 Strobes Description	228
Table 53: OEM7720 Strobe Electrical Specifications	229
Table 54: EVENT_IN, EVENT_OUT and PPS Pin Designation	242
Table 55: Bill of Materials (critical components)	242
Table 56: PV Pin Designation	243
Table 57: PV LED Driver Bill of Materials (critical components)	243
Table 58: CAN Transceiver Pin Designation	245
Table 59: CAN Transceiver Example Bill of Materials (critical components)	245
Table 60: USB Device Interface Pin Designation	246
Table 61: USB Device Interface Example Bill of Materials	247
Table 62: USB Host Interface Pin Designation	248
Table 63: USB Host Interface Example Bill of Materials	248
Table 64: Ethernet Pin Designation	249
Table 65: Ethernet Transformer Characteristics	250
Table 66: Bill of Materials (critical components)	250
Table 67: OEM7 Receivers	254
Table 68: GNSS Antennas	255
Table 69: GNSS Antenna Cables	256
Table 70: Receiver Card Mounting Accessories	256
Table 71: Targeted Peripheral List for OEM7 USB Embedded Host	257

Table 72: Devices Tested for OEM7 USB Embedded Host	257
Table 73: Static-Accumulating Materials	260

Receiver Card Notices

The following notices apply to the OEM7 family products.



Changes or modifications to this equipment, not expressly approved by NovAtel Inc., could void the user's authority to operate this equipment.

FCC

The devices covered by this manual comply with part 15 of the FCC Rules. Operation is subject to the following two conditions: (1) this device may not cause harmful interference, and (2) this device must accept any interference received, including interference that may cause undesired operation.

The equipment listed has been tested and found to comply with the limits for a Class B digital device, pursuant to part 15 of the FCC Rules. The Class B limits are designed to provide reasonable protection against harmful interference in a residential installation. The equipment listed generates, uses, and can radiate radio frequency energy and, if not installed and used in accordance with the instructions, may cause harmful interference to radio communications. However, there is no guarantee that interference will not occur in a particular installation. If this equipment does cause harmful interference to radio or television reception, which can be determined by turning the equipment off and on, the user is encouraged to try to correct the interference by one or more of the following measures:

- Reorient or relocate the receiving antenna
- Increase the separation between the equipment and the receiver
- Connect the equipment to an outlet on a circuit different from that to which the receiver is connected
- Consult the dealer or an experienced radio/TV technician for help

Innovation, Science and Economic Development (ISED) Canada

OEM7 Class B digital device complies with Canadian ICES-003.

OEM7 appareils numérique de la classe B sont conforme à la norme NMB-003 du Canada.

This device complies with ISED license-exempt RSS-GEN and RSS-247. Operation is subject to the following two conditions: (1) this device may not cause interference and (2) this device must accept any interference, including interference that may cause undesired operation of the device.

Cet appareil est conforme à la norme ISED RSS-GEN et RSS-247. Son fonctionnement est soumis aux deux conditions suivantes: (1) cet appareil ne doit pas provoquer d'interférences et (2) cet appareil doit accepter toute interférence, y compris les interférences pouvant entraîner un fonctionnement indésirable de l'appareil.

European Union (EU) / United Kingdom (UK)

NovAtel Inc. declares that the OEM7 GNSS receiver is in compliance with:

1. EU Directive 2014/53/EU
2. UK Regulations S.I. 2017/1206

The full text of the Declaration of Conformity may be obtained from the NovAtel website at: novatel.com/products/novatel-compliance.

WEEE

If you purchased your OEM7 family product in Europe or the United Kingdom, please return it to your dealer or supplier at the end of life. The objectives NovAtel's environment policy are, in particular, to preserve, protect and improve the quality of the environment, protect human health and utilise natural resources prudently and rationally. Sustainable development advocates the reduction of wasteful consumption of natural resources and the prevention of pollution. Waste Electrical and Electronic Equipment (WEEE) is a regulated area. Where the generation of waste cannot be avoided, it should be reused or recovered for its material or energy. WEEE

products may be recognized by their wheeled bin label ()

See novatel.com/products/novatel-compliance/novatel-environmental-compliance for more information.

RoHS

The OEM7 GNSS receivers are in conformity with:

1. Directive 2011/65/EU of the European Parliament and of the council of 8 June 2011 on the restriction of the use of certain hazardous substances in electrical and electronic equipment.
2. the Restriction of the Use of Certain Hazardous Substances in Electrical and Electronic Equipment (Amendment) Regulations 2012 (S.I. 2012/3032).

Lightning Protection

For a permanent or a fixed station installation, NovAtel recommends the installation of a lightning protection device for the GNSS antenna cable and/or radio antenna cable at the building entry point in accordance with the local electrical code.

Equipment protection measures should include:

- Selection of a suitable Lightning/Surge protection device
- Safety/Equipment rack grounding
- Lightning/Surge Protection of power lines and communication ports at the building entry point

For more information regarding the selection of surge protection devices for your application, the following websites are provided as a reference.

www.polyphaser.com/

www.hubersuhner.com



Only qualified personnel, such as electricians mandated by the governing body in the country of installation, may install lightning protection devices.

Conventions

The following conventions are used in this manual:



Information that supplements or clarifies text.



A caution that actions, operation or configuration may lead to incorrect or improper use of the hardware.



A warning that actions, operation or configuration may result in regulatory noncompliance, safety issues or equipment damage.

Customer Support

NovAtel Knowledge Base

If you have a technical issue, visit the NovAtel Support page at novatel.com/support. Through the *Support* page you can contact Customer Support, find papers and tutorials or download the latest firmware. To access the latest user documentation, visit docs.novatel.com/OEM7.

Before Contacting Customer Support

Before contacting NovAtel Customer Support about a software problem, perform the following steps:



If logging data over an RS-232 serial cable, ensure that the configured baud rate can support the data bandwidth (see **SERIALCONFIG** command). NovAtel recommends a minimum suggested baud rate of 230400 bps.

1. Log the data suggested in the appropriate *Troubleshooting Logs* section to a file on your computer for 15 minutes.
 - *General Troubleshooting Logs* on the next page
 - *Tracking and Interference Troubleshooting Logs* on the next page
 - *SPAN Troubleshooting Logs* on page 19
 - *RTK Troubleshooting Logs* on page 19
 - *PPP Troubleshooting Logs* on page 20
 - *ALIGN Troubleshooting Logs* on page 20

If using NovAtel Application Suite, log the Troubleshooting message set for 15 minutes.

2. Send the data file to NovAtel Customer Support: support.novatel@hexagon.com
3. You can also issue a **FRESET** command to the receiver to clear any unknown settings.



The **FRESET** command will erase all user settings. You should know your configuration (by requesting the RXCONFIGA log) and be able to reconfigure the receiver before you send the **FRESET** command.

If you are having a hardware problem, send a list of the troubleshooting steps taken and the results.

Contact Information

Log a support request with NovAtel Customer Support using one of the following methods:

Log a Case and Search Knowledge:

Website: novatel.com/support

Log a Case, Search Knowledge and View Your Case History: (login access required)

Web Portal: <https://novatelsupport.force.com/community/login>

E-mail:

support.novatel@hexagon.com

Telephone:

U.S. and Canada: 1-800-NOVATEL (1-800-668-2835)

International: +1-403-295-4900

General Troubleshooting Logs

```
LOG RXSTATUSB ONCHANGED
LOG RAWEPHEMB ONNEW
LOG GLORAWEPHEMB ONNEW
LOG BESTPOSB ONTIME 1
LOG RANGE B ONTIME 1
LOG RXCONFIGA ONCE
LOG VERSIONA ONCE
LOG LOGLISTA ONCE
LOG PORTSTATSA ONTIME 10
LOG PROFILEINFOA ONCE
LOG HWMONITORA ONTIME 10
```

Tracking and Interference Troubleshooting Logs

```
LOG VERSIONA ONCE
LOG RXCONFIGA ONCE
LOG CHANCONFIGLISTB ONCE
LOG PASSTHROUGH A ONNEW
LOG RXSTATUSB ONCHANGED
LOG CLOCKSTEERINGB ONCHANGED
LOG RAWEPHEMB ONNEW
LOG GLORAWEPHEMB ONNEW
LOG GALINAVRAWEPHEMERISB ONNEW
LOG BDSEPHEMERISB ONNEW
LOG QZSSEPHEMERISB ONNEW
LOG NAVICEPHEMERISB ONNEW
LOG RAWALMB ONNEW
LOG GLORAWALMB ONNEW
LOG GALALMANACB ONNEW
LOG BDSALMANACB ONNEW
LOG QZSSALMANACB ONNEW
LOG NAVICALMANACB ONNEW
LOG IONUTCB ONNEW
LOG GLOCLOCKB ONNEW
LOG GALCLOCKB ONNEW
LOG BDSLOCKB ONNEW
LOG TRACKSTATB ONTIME 1
LOG RANGE B ONTIME 1
LOG BESTPOSB ONTIME 1
LOG SATVIS2B ONTIME 30
LOG ITDETECTSTATUSB ONCHANGED
```

For dual antenna receivers, add these logs:

```
LOG TRACKSTATB_1 ONTIME 1
LOG RANGE B_1 ONTIME 1
```

For interference issues add this log.

```
LOG ITPSDDETECTB ONNEW
```

For interference issues, when you have enough datalink bandwidth to handle large logs, add this log:

```
LOG ITPSDFINALB ONNEW
```

SPAN Troubleshooting Logs

```
LOG RXSTATUSB ONCHANGED
LOG RAWEPHEMB ONNEW
LOG GLORAWEPHEMB ONNEW
LOG GALINAVRAWEPHEMERISB ONNEW
LOG BDSEPEHEMERISB ONNEW
LOG BESTPOSB ONTIME 1
LOG RANGE B ONTIME 1
LOG RXCONFIGA ONCE
LOG VERSIONA ONCE
LOG RAWIMUSXB ONNEW
LOG INSUPDATESTATUSB ONCHANGED
LOG INSPVAXB ONTIME 1
LOG INSCONFIGA ONCHANGED
LOG BESTGNSSPOSB ONTIME 1
```

RTK Troubleshooting Logs

```
LOG RXSTATUSB ONCHANGED
LOG RAWEPHEMB ONNEW
LOG GLORAWEPHEMB ONNEW
LOG QZSSRAWEPHEMB ONNEW
LOG BDSRAWNAVSUBFRAMEB ONNEW
LOG GALFNAVRAWEPHEMERISB ONNEW
LOG GALINAVRAWEPHEMERISB ONNEW
LOG RANGE B ONTIME 1.0
LOG BESTPOSB ONTIME 1.0
LOG RXCONFIGB ONCE
LOG VERSIONB ONCE
LOG TRACKSTATB ONTIME 1.0
LOG RTKPOSB ONTIME 1.0
LOG MATCHEDPOSB ONNEW
LOG MATCHEDSATS B ONNEW
LOG RTKSATS B ONTIME 1.0
LOG PSRPOSB ONTIME 1.0
LOG RAWALMB ONNEW
LOG IONUTCB ONNEW
LOG GLORAWALMB ONNEW
LOG GLOCLOCKB ONNEW
LOG PASSTHROUGH B ONNEW
LOG CLOCKMODEL B ONTIME 1.0
LOG REFSTATION B ONNEW
LOG RTKVELB ONTIME 1.0
```

PPP Troubleshooting Logs

LOG RXSTATUSB ONCHANGED
LOG GPSEPHEMB ONNEW
LOG GLOEPHEMERISB ONNEW
LOG QZSSEPHEMERISB ONNEW
LOG BDSEPHEMERISB ONNEW
LOG BDSBCNAV1EPHEMERISB ONNEW (firmware versions 7.08.03 and 7.08.10 and later)
LOG BDSBCNAV2EPHEMERISB ONNEW (firmware versions 7.08.03 and 7.08.10 and later)
LOG BDSBCNAV3EPHEMERISB ONNEW (firmware versions 7.08.03 and 7.08.10 and later)
LOG GALFNAVEPHEMERISB ONNEW
LOG GALINAVEPHEMERISB ONNEW
LOG RANGE B ONTIME 1.0
LOG BESTPOS B ONTIME 1.0
LOG RXCONFIG B ONCE
LOG VERSION B ONCE
LOG TRACKSTAT B ONTIME 10.0
LOG LBANDTRACKSTAT B ONTIME 1.0
LOG PPPPOS B ONTIME 1.0
LOG PPPSAT B ONTIME 1.0
LOG TERRASTARINFO B ONCHANGED
LOG TERRASTARSTATUS B ONCHANGED
LOG PSRPOS B ONTIME 1.0
LOG ALMANAC B ONNEW
LOG GLOALMANAC B ONNEW
LOG GALALMANAC B ONNEW
LOG BDSALMANAC B ONNEW
LOG QZSSALMANAC B ONNEW
LOG IONUTCB ONNEW
LOG GLOCLOCK B ONNEW
LOG LBANDBEAMTABLE B ONCHANGED

ALIGN Troubleshooting Logs

LOG RXSTATUSB ONCHANGED
LOG RAWEPHEMB ONNEW
LOG GLORAWEPHEMB ONNEW
LOG GALINAVRAWEPHEMERISB ONNEW
LOG BDSEPHEMERISB ONNEW
LOG BESTPOS B ONTIME 1
LOG RANGE B ONTIME 1
LOG RXCONFIG A ONCE
LOG VERSION A ONCE
LOG LOGLISTA ONCE
LOG PORTSTATSA ONTIME 10
LOG ALIGNBSLNENUB ONNEW
LOG ALIGNBSLNXYZB ONNEW
LOG ALIGNDOPB ONNEW
LOG HEADING2B ONNEW
LOG MASTERPOS B ONNEW
LOG ROVERPOS B ONNEW (This log can only be output if you have Y model ALIGN)
LOG HEADINGSATSA ONNEW (This log can only be output on the ALIGN rover)
LOG DUALANTENNAHEADING B ONTIME 1.0
LOG TRACKSTAT B_1 ONTIME 1 (Dual antenna receivers only)
LOG RANGE B_1 ONTIME 1 (dual antenna receivers only)

Chapter 1 Introduction

The OEM7 family offers Global Navigation Satellite System (GNSS) receivers and integrated L-Band capability. The OEM7 family supports existing and planned GPS, GLONASS, BeiDou, Galileo and QZSS frequencies and is capable of full code and Real-Time Kinematic (RTK) positioning.

OEM7 Family Receiver Cards

- OEM719 – refer to *OEM719 Receiver Overview* on page 23 for details
- OEM729 – refer to *OEM729 Receiver Overview* on page 24 for details
- OEM7600 – refer to *OEM7600 Receiver Overview* on page 25 for details
- OEM7700 – refer to *OEM7700 Receiver Overview* on page 26 for details
- OEM7720 – refer to *OEM7720 Receiver Overview* on page 27 for details

1.1 OEM7 Receiver Card Overview

In addition to the NovAtel OEM7 receiver card, an OEM7 receiver system requires the following:

- Enclosure and wiring harness
- Power supply
- Data communications equipment
- GNSS antenna

An OEM7 receiver system is illustrated in *Figure 1: OEM7 Receiver System* below and described in the sections that follow.

Figure 1: OEM7 Receiver System

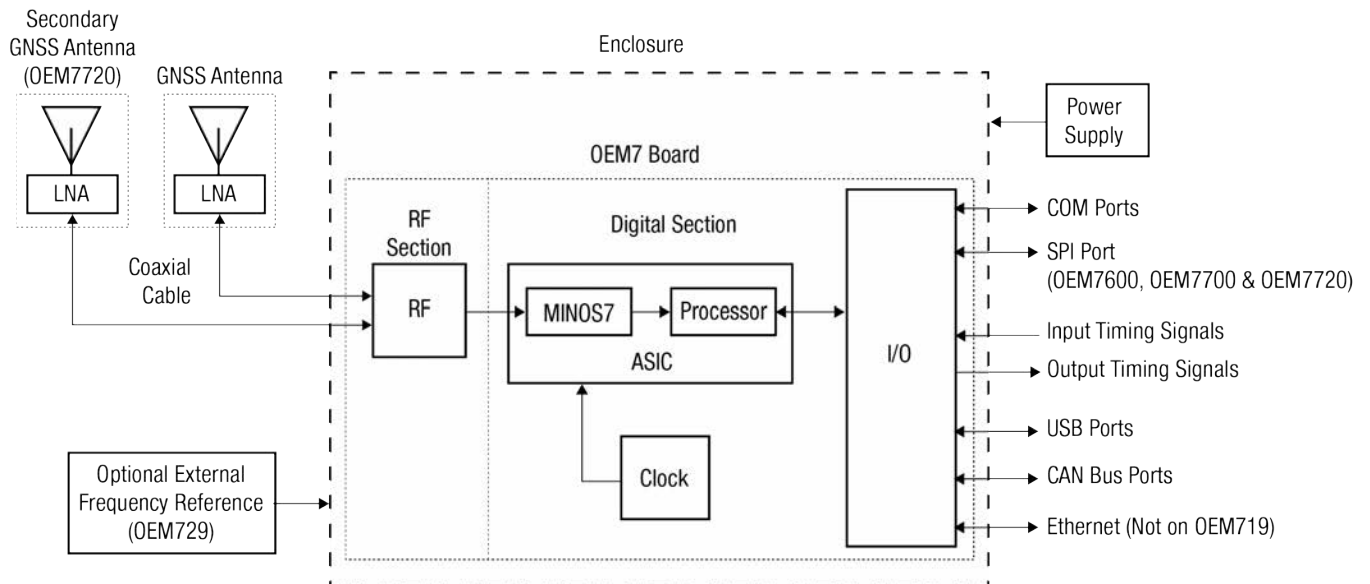

1.1.1 OEM7 Family Card

NovAtel's OEM7 family cards consist of a Radio Frequency (RF) section and a digital section.

Radio Frequency (RF) Section

The receiver obtains GNSS signals from the antenna. The RF section down converts the incoming RF signals to Intermediate Frequency (IF) signals which are processed by the digital section. The RF section also supplies power to the active antenna Low Noise Amplifier (LNA) through the coaxial cable. The RF section has been designed to reject common sources of interference.

Digital Section

The heart of the digital section is NovAtel's MINOS7 ASIC (Application Specific Integrated Circuit). The digital section digitizes and processes the IF signals to obtain a GNSS solution (position, velocity and time). It also processes the system I/O, shown in *Figure 1: OEM7 Receiver System* on the previous page.

1.1.2 Enclosure

An enclosure is necessary to protect the OEM7 receiver card from environmental extremes (moisture, dust, etc.).

1.1.3 GNSS Antenna

The receiver can supply power for the antenna LNA. If the antenna is not compatible with the OEM7 power supply (5 VDC), an external LNA supply may be required.

1.1.4 Power Supply

A power supply capable of delivering the minimum receiver operating voltage and power is required. See *Power Supply Requirements for Receiver Cards* on page 30 for details.

1.1.5 Optional External Frequency Reference

When applications require greater precision than the OEM7 internal clock, connect the receiver to an external high stability oscillator. See *External Oscillator* on page 83 for more information.



An External Oscillator is supported only on the OEM729.

1.1.6 Data Communications Equipment

A computer or other data communications device is necessary to communicate with the receiver and to receive and store the data that the receiver provides.

1.1.7 OEM719 Receiver Overview

The OEM719 has the same form and fit as NovAtel's OEM615 receiver, with the following features:

- Multi-frequency/Multi-constellation:
GPS L1 C/A, L1C, L2C, L2P, L5; GLONASS L1 C/A, L2 C/A, L2P, L3; BeiDou B1I, B1C, B2I, B2a, B2b, B3I; Galileo E1, E5 AltBOC, E5a, E5b, E6; NavIC L5; QZSS L1 C/A, L1C, L1S, L2C, L5, L6; SBAS L1, L5
- LVCMOS UART communications ports
- USB device port (with virtual COM ports)
- Internal LNA power supply
- PPP, RTK, SBAS and DGPS positioning solutions
- GLIDE and ALIGN positioning options
- SPAN GNSS+INS capable
- Enhanced interference mitigation
- Mechanical mounting rails

Figure 2: OEM719 Receiver Board



OEM719 technical specifications are provided in *OEM719 Technical Specifications* on page 134.

1.1.8 OEM729 Receiver Overview

The OEM729 has the same form and fit as NovAtel's OEM628 receiver, with the following features:

- Multi-frequency/Multi-constellation:
GPS L1 C/A, L1C, L2C, L2P, L5; GLONASS L1 C/A, L2 C/A, L2P, L3; BeiDou B1I, B1C, B2I, B2a, B2b, B3I; Galileo E1, E5 AltBOC, E5a, E5b, E6; NavIC L5; QZSS L1 C/A, L1C, L1S, L2C, L5, L6; SBAS L1, L5
- External oscillator input
- RS-232/RS-422 communications port
- LVCMOS UART communications ports
- USB communications port (with virtual COM ports)
- Ethernet communications port
- PPP, RTK, SBAS and DGPS positioning solutions
- GLIDE and ALIGN positioning options
- SPAN GNSS+INS capable
- Enhanced interference mitigation
- Mechanical mounting rails

Figure 3: OEM729 Receiver Board

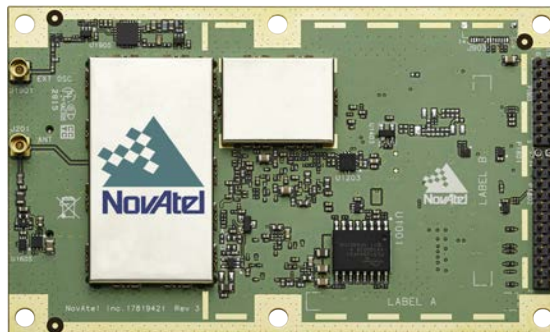

OEM729 technical specifications are provided in *OEM729 Technical Specifications* on page 154.

1.1.9 OEM7600 Receiver Overview

The OEM7600 is an extremely compact OEM7 receiver with the following features:

- Multi-frequency/Multi-constellation:
GPS L1 C/A, L1C, L2C, L2P, L5; GLONASS L1 C/A, L2 C/A, L2P, L3; BeiDou B1I, B1C, B2I, B2a, B2b;
Galileo E1, E5 AltBOC, E5a, E5b; NavIC L5; QZSS L1 C/A, L1C, L1S, L2C, L5; SBAS L1, L5
- LVCMOS UART communications ports
- USB communications ports
- Ethernet communications port
- High density connector for increased connectivity options
- PPP, RTK, SBAS and DGPS positioning solutions
- GLIDE and ALIGN positioning options
- SPAN GNSS+INS capable
- Enhanced interference mitigation
- Integrated RF shield

Figure 4: OEM7600 Receiver Board



OEM7600 technical specifications are provided in *OEM7600 Technical Specifications* on page 174.

1.1.10 OEM7700 Receiver Overview

The OEM7700 is the same size as NovAtel's OEM615 receiver with the following features:

- Multi-frequency/Multi-constellation:
GPS L1 C/A, L1C, L2C, L2P, L5; GLONASS L1 C/A, L2 C/A, L2P, L3; BeiDou B1I, B1C, B2I, B2a, B2b, B3I; Galileo E1, E5 AltBOC, E5a, E5b, E6; NavIC L5; QZSS L1 C/A, L1C, L1S, L2C, L5, L6; SBAS L1, L5
- LVCMOS UART communications ports
- USB communications ports
- Ethernet communications port
- High density connector for increased connectivity options
- PPP, RTK, SBAS and DGPS positioning solutions
- GLIDE and ALIGN positioning options
- SPAN GNSS+INS capable
- Enhanced interference mitigation
- Mechanical mounting rails

Figure 5: OEM7700 Receiver Board



OEM7700 technical specifications are provided in *OEM7700 Technical Specifications* on page 195.

1.1.11 OEM7720 Receiver Overview

The OEM7720 is the same size as NovAtel's OEM617D receiver with the following features:

- Dual antenna inputs
- Multi-frequency/Multi-constellation:
GPS L1 C/A, L2C, L2P, L5; GLONASS L1 C/A, L2 C/A, L2P, L3; BeiDou B1I, B1C, B2I, B2a, B2b; Galileo E1, E5 AltBOC, E5a, E5b; QZSS L1 C/A, L1C, L1S, L2C, L5; SBAS L1, L5
- LVCMOS UART communications ports
- USB communications ports
- Ethernet communications port
- High density connector for increased connectivity options
- PPP, RTK, SBAS and DGPS positioning solutions
- GLIDE and ALIGN positioning options
- SPAN GNSS+INS capable
- Enhanced interference mitigation
- Mechanical mounting rails

Figure 6: OEM7720 Receiver Board



OEM7720 technical specifications are provided in *OEM7720 Technical Specifications* on page 217.

1.2 Related Documents and Information

After the receiver is set up, the [OEM7 Commands and Logs Reference Manual](#) becomes the primary source for command and log information.



Each receiver has a specific set of features, so some commands and logs may not be supported by your model.

For instructions on configuring and using SPAN functionality, refer to the [OEM7 SPAN Installation and Operation User Manual](#).

Refer to our web site docs.novatel.com/OEM7 for the latest documentation.

This manual does not cover receiver service and repair. Contact a local NovAtel dealer for service or repair inquiries (refer to *Customer Support* on page 17 for contact details).

Chapter 2 OEM7 Family Receiver Cards Installation

This chapter provides instructions and guidelines for checking the contents of the shipping box and integrating a NovAtel receiver into a GNSS receiver system.

2.1 Additional Equipment Required

For the receiver to perform optimally, the following additional equipment is required:

- Interface for power, communications and other signals
- Enclosure to protect against the environment
- GNSS antenna (for a list of NovAtel GNSS antennas refer to our web site novatel.com/products/antennas)
- Coaxial cable (and interconnect adapter cable, as necessary)
- Data communication equipment capable of serial, USB or Ethernet communication
- Serial, USB or Ethernet data cable
- Power supply
- Optional NovAtel OEM7 Development Kit (01019433)
OEM7 Development Kit Guide (GM-14915145)



When the OEM7 receiver is installed in a permanent location, it should be protected by a lightning protection device according to local building codes (refer to the *Lightning Protection* on page 15).



Emissions

OEM7 receiver products have been designed and tested to meet regulatory emission limits. Emission levels may be higher for OEM7 receiver card level operation than for integrated enclosure level products using an OEM7 receiver card.

Refer to *Receiver Card Notices* on page 14 for more information.

2.2 Selecting a GNSS Antenna

NovAtel offers a variety of GNSS antennas, including single, dual and triple-frequency, triple-band and wide-band reference antennas (refer to our web site: novatel.com/products/antennas for details of available antennas). All antennas include band pass filtering and an LNA. The GNSS antenna chosen depends on the particular application. Each model offers exceptional phase center stability and a significant measure of immunity against multipath interference. Each antenna has an environmentally sealed radome and all meet the European Union's Restriction of Hazardous Substances (RoHS) and Waste Electrical and Electronic Equipment (WEEE).

If a non-NovAtel GNSS antenna is chosen, a typical antenna LNA gain between 26 dB to 30 dB is recommended in a rover station application.



A dual frequency capable GNSS antenna is required to use SPAN, RTK, ALIGN or dual frequency GLIDE.

An L-Band capable antenna is required to receive TerraStar corrections.

For more information about antenna selection, see *Importance of Antenna Selection* on page 251.

2.3 Choosing a Coaxial Cable

An appropriate coaxial cable matches the impedances of the antenna and receiver (50 ohms) and has a line loss not exceeding 10.0 dB. If the limit is exceeded, excessive signal degradation may occur and the receiver may not meet performance specifications. NovAtel offers several coaxial cables to meet GNSS antenna interconnection requirements, including:

- 5 m, 15 m and 30 m antenna cable with TNC connectors on both ends (NovAtel part numbers GPS-C006, GPS-C016 and GPS-C032)
- 2.5 m and 5 m antenna cable with an SMA connector on one end and a TNC connector on the other (NovAtel part numbers 60723177 and 60723178)



The SMA to TNC cables (60723177 and 60723178) are not recommended for permanent outdoor use.



For more information about antenna cabling, including using cables longer than 30 m and in-line amplifiers, refer to [APN-077: RF Equipment Selection and Installation](#) available from (novatel.com/support/support-materials/application-notes).



A conversion is required between the MMCX, MMBX or MCX connector on the OEM7 receiver card and the female TNC connector on NovAtel's GNSS antennas.



NovAtel recommends using high quality coaxial cables because an impedance mismatch is possible when using lower quality cables and this produces reflections in the cable that increases signal loss. Although other high quality antenna cables can be used, the performance specifications of the OEM7 receivers are warranted only when used with NovAtel supplied accessories.

2.4 Power Supply Requirements for Receiver Cards

OEM7 receivers require a power supply that provides:

- +3.3 VDC \pm 5% with less than 100 mV ripple

The requirement above works for all OEM7 receiver cards. However, the OEM7720 receiver supports a wider range of power supply voltage: +3.0 to 5.0 VDC.



If the voltage supplied is below the minimum specification, the receiver suspends operation. If the voltage supplied is above the maximum specification, the receiver may be permanently damaged, voiding the warranty.



OEM7 receiver cards contain a DC-to-DC converter, tolerant to input noise and ripple. A tightly regulated input supply is not required, as long as it falls within the given input range.

Refer to the following for complete power specifications:

- *OEM719 Electrical and Environmental Specifications* on page 144
- *OEM729 Electrical and Environmental Specifications* on page 160
- *OEM7600 Electrical and Environmental Specifications* on page 179
- *OEM7700 Electrical and Environmental Specifications* on page 201
- *OEM7720 Electrical and Environmental Specifications* on page 224

2.5 Card Installation Overview

When the appropriate equipment is selected, complete the following steps to set up and begin using the NovAtel GNSS receiver.

1. Ensure adequate ESD protection is used as described in *Electrostatic Discharge (ESD) Precautions* below.
2. Prepare the interface with the receiver's data, status and power signals using the information in *Preparing the Data, Signal and Power Interface* on page 39.
3. Connect the GNSS antenna adapter cable to the receiver (refer to *Connecting the Antenna to the Receiver Card* on page 46).
4. Mount the OEM7 receiver card in a secure enclosure to reduce environmental exposure and RF interference, as described in *Mounting the Printed Circuit Board* below.
5. Mount the GNSS antenna to a secure, stable structure (refer to *Mounting the GNSS Antenna* on page 45).
6. Apply power to the receiver as described in *Applying Power to the Receiver Card* on page 47.
7. Connect the receiver to a computer or other data communications equipment (refer to *Connecting Data Communications Equipment* on page 47 for instructions).

2.5.1 Electrostatic Discharge (ESD) Precautions

When the OEM7 receiver card is removed from the original packing box, keep the box and ESD protection for future storage or shipment. Leave the OEM7 receiver card in the static shielding bag or clamshell when not connected in a normal operating environment.



- Always wear a properly grounded anti-static wrist strap when handling OEM7 cards.
- Always hold the OEM7 receiver card by the corners or the RF shield: avoid direct contact with any of the components.
- Never let the OEM7 receiver card come in contact with clothing. The ground strap cannot dissipate static charges from fabrics.
- Failure to follow accepted ESD handling practices could cause damage to the OEM7 receiver card.
- The warranty may be void if equipment is damaged by ESD.

For more ESD information, see *Electrostatic Discharge (ESD) Practices* on page 259.

2.6 Mounting the Printed Circuit Board

The OEM7 family receiver cards are OEM products and the printed circuit board is provided without a housing structure. This allows flexibility in creating a mounting environment to suit particular product and market

requirements.

The mounting and enclosure should provide for the following:

- Mounting of external connectors
- Protection from hostile physical environments (rain, snow, sand, salt, water, extreme temperatures, etc)



The OEM Integrator is responsible for ensuring compliance of the final product with the regulatory bodies for those intended markets.

- Protection from ESD (see *Electrostatic Discharge (ESD) Practices* on page 259)
- Location to securely mount the receiver using screws

2.6.1 Planning the Mount Location

When planning the mount location for the OEM7 receiver, ensure there is enough room for the card. There is an area around the card, called a keep-out zone, where other components in the enclosure can not intrude. This keep-out zone is intended to prevent other components in the enclosure from interfering with, or damaging, the OEM7 receiver. For diagrams of the exact dimensions and keep-out zones for each OEM7 receiver card, see:

- *OEM719 Mechanical Specifications* on page 137
- *OEM729 Mechanical Specifications* on page 157
- *OEM7600 Mechanical Specifications* on page 177
- *OEM7700 Mechanical Specifications* on page 198
- *OEM7720 Mechanical Specifications* on page 221

OEM7 receivers are not directional in nature and can be mounted in any orientation.

2.6.2 Board to Board Spacing

A minimum amount of space is required between the OEM7 receiver and the interface or system board the receiver connects to. Refer to the following table for the minimum and suggested spacing.

OEM7 Receiver	Antenna Connector Type	Minimum Spacing	Suggested Spacing	Notes
OEM719	MCX straight	11.00 mm	12.00 mm	Mounting rails are available from NovAtel. See <i>Table 1: NovAtel Mounting Rails</i> on page 36 for the rails available.
OEM719A	MCX right angle	7.00 mm	7.00 mm 10.00 mm 12.00 mm	
OEM719B	MMBX straight	7.00 mm	7.00 mm 10.00 mm 12.00 mm	
OEM7600	MMCX right angle	7.00 mm	7.00 mm	
OEM7700	MMBX straight	7.00 mm	7.00 mm 10.00 mm	
OEM7720	MMBX straight	7.00 mm	7.00 mm 10.00 mm	



The recommended minimum values in the previous table assumes no recesses or cut-outs in the interface or system board for antenna connection.

A component keep-out area may be needed below the antenna connector on the mating interface or system board to facilitate minimum or suggested spacing.

Board to board spacing less than the minimum spacing suggested in the table may be achieved by incorporating recesses or cut-outs in mating interface or system board.

2.6.3 Mounting Options

OEM7 receivers can be mounted using standoffs, rails or rails and clamping bars.



The OEM7600 has integrated mounting rails and does not require additional standoffs, rails or clamping bars. See *Mounting the OEM7600* on page 37 for mounting details.

Figure 7: Mounting with Standoffs

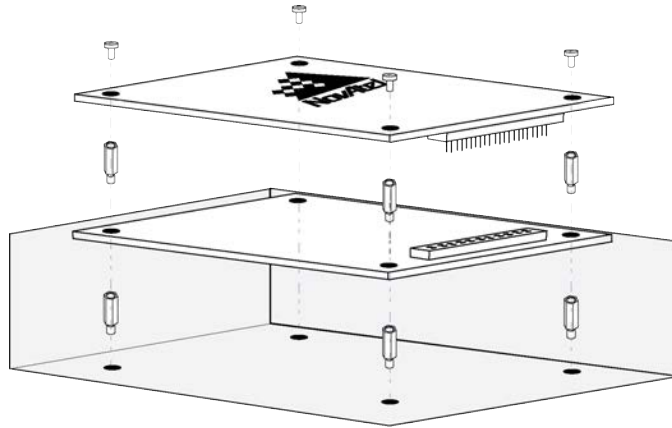

Figure 8: Mounting with Rails

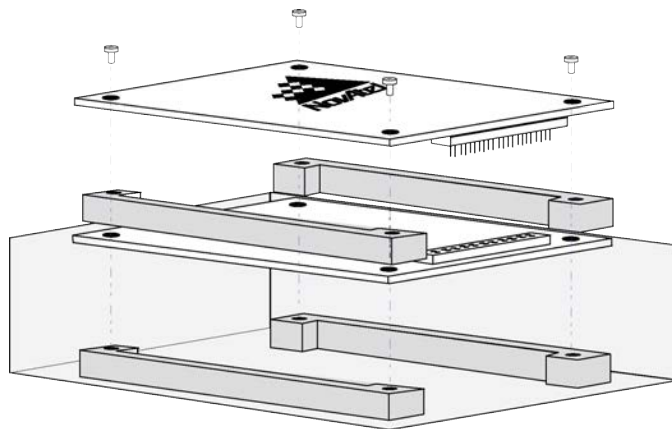
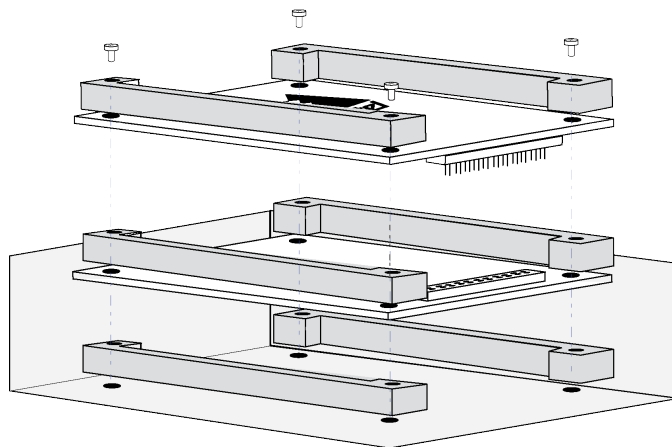

Figure 9: Mounting with Rails and Clamping Bars



The mounting holes in the OEM7 receiver cards accept M3 fasteners with a maximum projected head diameter of 7.5 mm (0.295"). For the exact spacing of the mounting holes, see *Figure 42: OEM719 Dimensions* on page 137, *Figure 49: OEM729 Dimensions* on page 157, *Figure 54: OEM7700 Dimensions* on page 198 and *Figure 57: OEM7720 Dimensions* on page 221.



For proper grounding and mechanical integrity, mount the OEM719, OEM7700 and OEM7720 with four screws.

For proper grounding and mechanical integrity, mount the OEM729 with six screws.



When installing cards, ensure all standoffs are properly installed.

Also ensure that the mounting location (whether using standoffs, bosses or rails) is level.

The amount of board deflection (bow and twist) must not exceed 0.75% of the receiver card's characteristic dimension. For example, on the OEM7700, which is 71 mm long and 46 mm wide, the deflection along the length must not exceed 0.53 mm and the deflection along the width must not exceed 0.34 mm.



Care needs to be taken when mating the OEM7700 or OEM7720 receiver to an interface card or system board. The high-density, 60 position connectors on both cards need to be properly aligned before mating to prevent damage to the connectors. See *Figure 10: Mounting the High-Density, 60 Pin Connector* on the next page.

A method to ensure proper alignment of the connectors is to slowly bring the mating faces together and let the connectors find their centers as the mating faces come to rest against each other. At this stage, visually check that the connectors are aligned. If the connectors are aligned, gently push the connectors together to mate them.

A fixture or jig will also be of help in ensuring proper alignment between the two connectors.

Figure 10: Mounting the High-Density, 60 Pin Connector

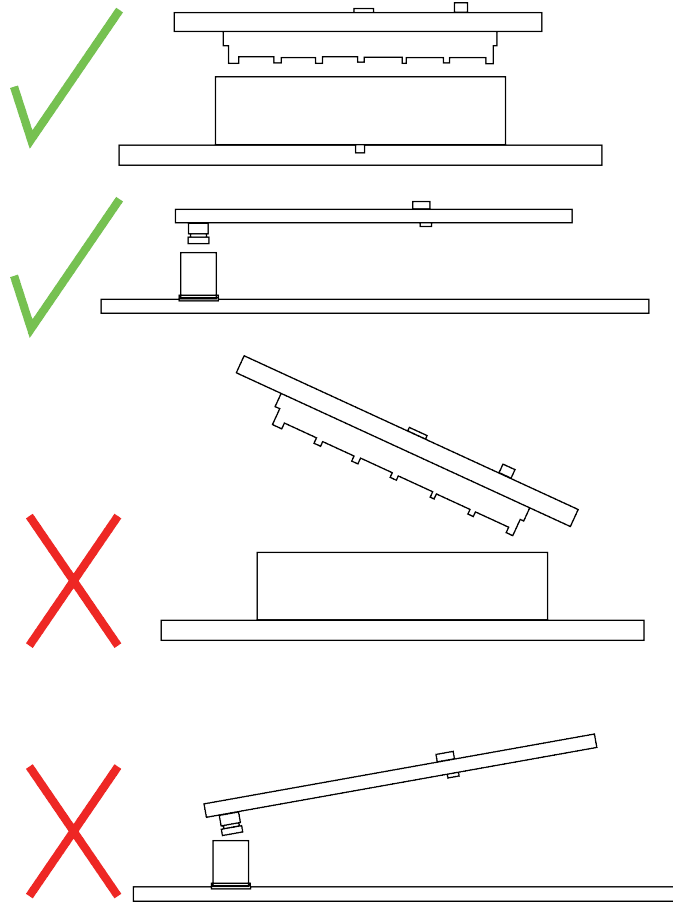

OEM7 receivers have an area on the edge of the cards to allow the use of mounting rails. This is the area of bare copper outside of the keep-out zone. On the OEM719, OEM7700 and OEM7720, this area is 1.75 mm wide. On the OEM729, this area is 2.5 mm wide. See *Figure 48: OEM719 Mounting Surface* on page 143, *Figure 51: OEM729 Mounting Surfaces* on page 159, *Figure 56: OEM7700 Mounting Surfaces* on page 200 and *Figure 59: OEM7720 Mounting Surfaces* on page 223 for the dimensions of this area.

For most non-demanding applications (e.g. base stations, remote sensing, desktop units and IT infrastructure), standoffs or bosses are sufficient to provide a secure mounting location.

Using rails to mount the OEM7 receiver improves the thermal and vibration performance of the receiver. Securing the OEM7 receiver to mounting rails using additional rails as clamping bars provides the most secure configuration for aggressive thermal and vibration applications. See *Table 1: NovAtel Mounting Rails* below for information about the OEM7 mounting rails available from NovAtel.

Table 1: NovAtel Mounting Rails

Rail Part Number	Rail Height	Use as Mounting Rail for	Use as Clamping Bar on
01019750	7 mm	OEM719 OEM7700 OEM7720	OEM719 OEM7700 OEM7720

Rail Part Number	Rail Height	Use as Mounting Rail for	Use as Clamping Bar on
01019751	10 mm	OEM719 OEM7700 OEM7720	OEM719 OEM7700 OEM7720
01019752	12 mm	OEM719	OEM719 OEM7700 OEM7720



Ensure the IO connector height and antenna cable/connector height facilitate the desired board to board spacing and do not violate OEM7 receiver card height keep-out zones. For the recommended mating connectors, refer to *Table 2: OEM7 Communication and I/O Connectors* on page 40.



For more details about mounting OEM7 receiver cards, contact Customer Support to obtain to the OEM7 Receiver Card Mechanical Integration Application Note (D19021) or OEM7600 Mechanical Application Note (D21177).

2.6.4 Mounting the OEM7600

The OEM7600 mounts to the interface or system board using four screws that pass through the interface board and into the mounting holes on the OEM7600 RF shield. For the exact spacing of the mounting holes, see *Figure 52: OEM7600 Dimensions* on page 177.

Figure 11: Mounting the OEM7600

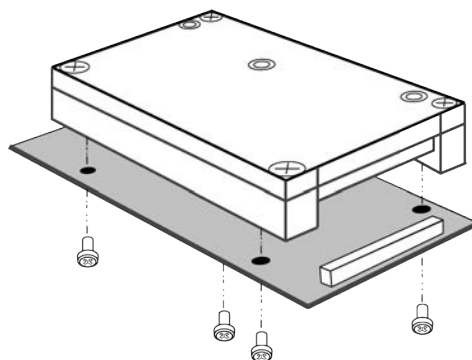

The mounting holes in the OEM7600 accept M3 fasteners. For proper grounding and mechanical integrity, mount the OEM7600 with four screws. The recommended torque rate for the mounting screws is 8 in-lbs.



The optimal screw penetration into the OEM7600 is 4.0 mm deep. When selecting screws for mounting the OEM7600, ensure the maximum screw penetration does not exceed 5 mm.



Care needs to be taken when mating the OEM7600 receiver to an interface card or system board. The high-density, 60 position connectors on both cards need to be properly aligned before mating to prevent damage to the connectors. See *Figure 10: Mounting the High-Density, 60 Pin Connector* on page 36.

A method to ensure proper alignment of the connectors is to slowly bring the mating faces together and let the connectors find their centers as the mating faces come to rest against each other. At this stage, visually check that the connectors are aligned. If the connectors are aligned, gently push the connectors together to mate them.

A fixture or jig will also be of help in ensuring proper alignment between the two connectors.

For the recommended mating connector for the OEM7600, refer to *Table 2: OEM7 Communication and I/O Connectors* on page 40.

2.6.5 Thermal Dissipation

To ensure functionality and reliability, the OEM7 receiver cards must operate within the specified ambient air temperature limits (-40°C to +85°C).

The OEM7 receivers have been designed to efficiently transfer heat from the receiver components into the printed circuit board. Mounting the OEM7 receiver on rails, or attaching heat sinks to the mounting areas, will transfer the heat from the receiver card to adjacent circuit boards, the enclosure or the air.



The mounting area is the area of bare copper on the sides of the receiver that are outside of the keep-out zone. See *Figure 48: OEM719 Mounting Surface* on page 143, *Figure 51: OEM729 Mounting Surfaces* on page 159, *Figure 56: OEM7700 Mounting Surfaces* on page 200 and *Figure 59: OEM7720 Mounting Surfaces* on page 223 .



The OEM7600 receiver RF shield has integrated mounting rails.



For more information about thermal dissipation, contact Customer Support to obtain to the OEM7 Receiver Card Mechanical Integration Application Note (D19021) or OEM7600 Mechanical Application Note (D21177).

2.6.6 OEM7720 Accessory Heat Spreader

The NovAtel Heat Spreader accessory (01020014) dissipates heat quickly to reduce component temperatures. Four M3 flat head screws are required to attach the Heat Spreader to the OEM7720 card (on the non-connector side) and two thermal interface pads need to be added. If necessary, mounting rails can also be used on the connector side of the OEM7720 card. Refer to *Figure 8: Mounting with Rails* on page 34 and *Table 1: NovAtel Mounting Rails* on page 36 for mounting rail details.

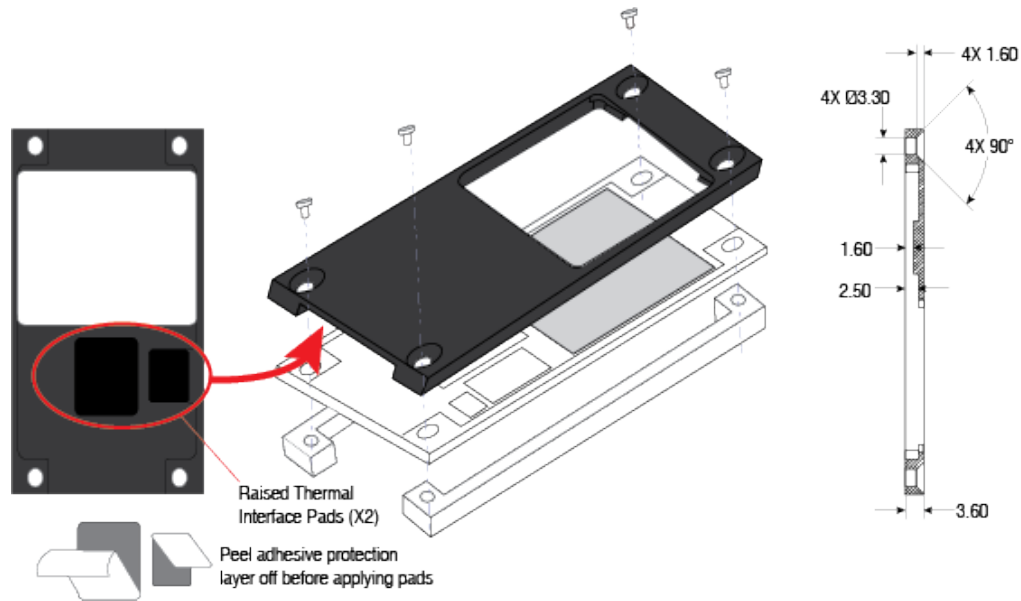
Figure 12: OEM7720 Heat Spreader Mounting Geometry

2.6.7 Vibration

OEM7 receivers are rated to 20 g RMS (MIL-STD-810G Method 514.6E-1, Category 24). However, for high vibration installations, special considerations are required.

For OEM719, OEM7700 and OEM7720 receiver cards to meet the 20 g vibration rating, the receiver card must be mounted using rails. OEM729 receivers meet the 20 g vibration rating using standoffs, bosses or rails. The OEM7600 receiver RF shield has integrated mounting rails and meets the 20 g vibration rating.



For more information about vibration considerations, contact Customer Support to obtain to the OEM7 Receiver Card Mechanical Integration Application Note (D19021) or OEM7600 Mechanical Application Note (D21177)

2.7 Preparing the Data, Signal and Power Interface

The interface provides connections to some or all of the following:

- Communication ports, including COM, Ethernet, USB and CAN
- Input and output timing strobes
- Power input
- RF signal input
- Optional external frequency reference

For all OEM7 receiver cards, the power, status and data inputs and outputs are accessed from the interface connector. The interface therefore, must be designed to mate with this connector.

Table 2: OEM7 Communication and I/O Connectors

Receiver	COM and I/O Connector	Mating Connector
OEM719	2 x 10 male header (2 mm pitch) See <i>OEM719 Interface Connector</i> on page 150	2 x 10 female socket (2 mm pitch)
OEM729	Main: 2 x 12 male header (2 mm pitch) Aux: 2 x 8 male header (2 mm pitch) See <i>OEM729 Interface Connectors</i> on page 167	Main: 2 x 12 female socket (2 mm pitch) Aux: 2 x 8 female socket (2 mm pitch)
OEM7600	2 x 30 female socket (0.8 mm pitch) See <i>OEM7600 Interface Connector</i> on page 185	2 x 30 male header (0.8 mm pitch) Samtec TEMS-130-02-04.0-H-D-A-K-TR (7 mm mated stack height)
OEM7700	2 x 30 female socket (0.8 mm pitch) See <i>OEM7700 Interface Connector</i> on page 207	2 x 30 male header (0.8 mm pitch) Samtec TEMS-130-02-07.0-H-D-A-K-TR (10 mm mated stack height) Samtec TEMS-130-02-04.0-H-D-A-K-TR (7 mm mated stack height)
OEM7720	2 x 30 female socket (0.8 mm pitch) See <i>OEM7720 Interface Connector</i> on page 230	2 x 30 male header (0.8 mm pitch) Samtec TEMS-130-02-07.0-H-D-A-K-TR (10 mm mated stack height) Samtec TEMS-130-02-04.0-H-D-A-K-TR (7 mm mated stack height)

Figure 13: OEM719 Connector and Indicator Locations

Top View

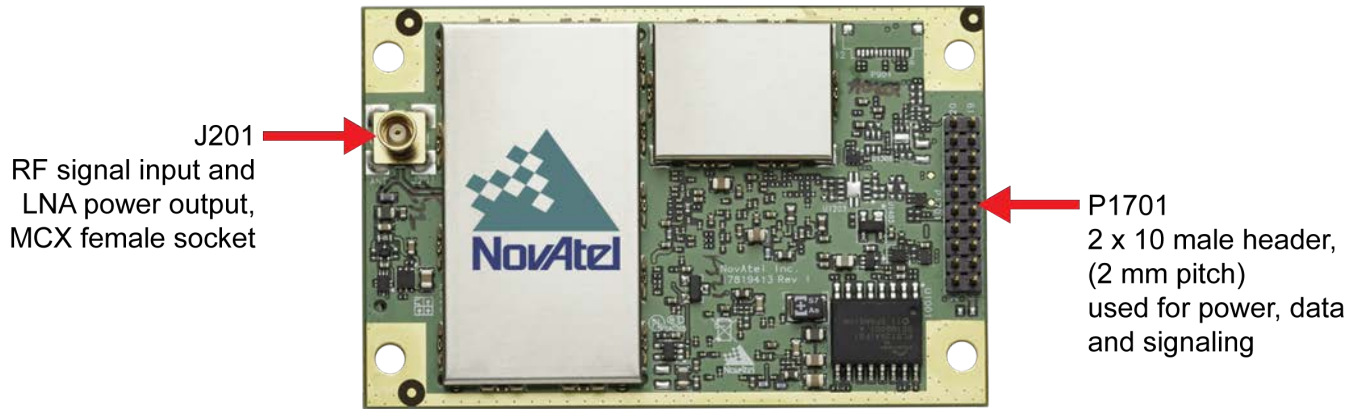

Bottom View

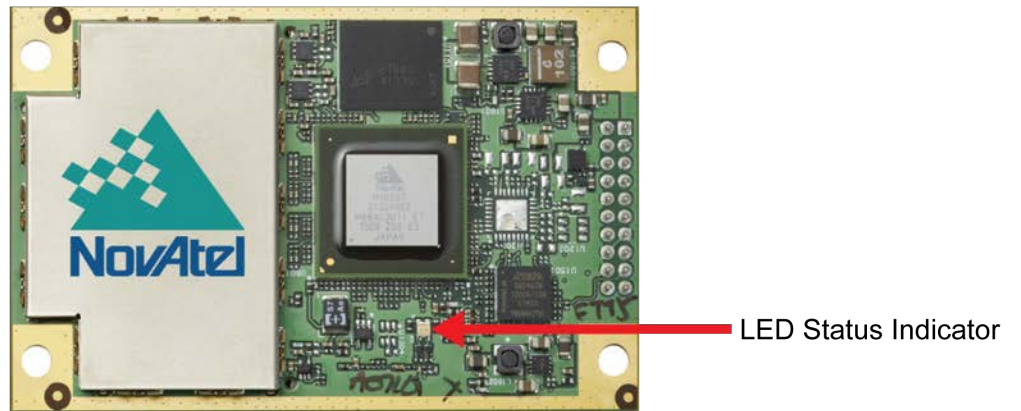
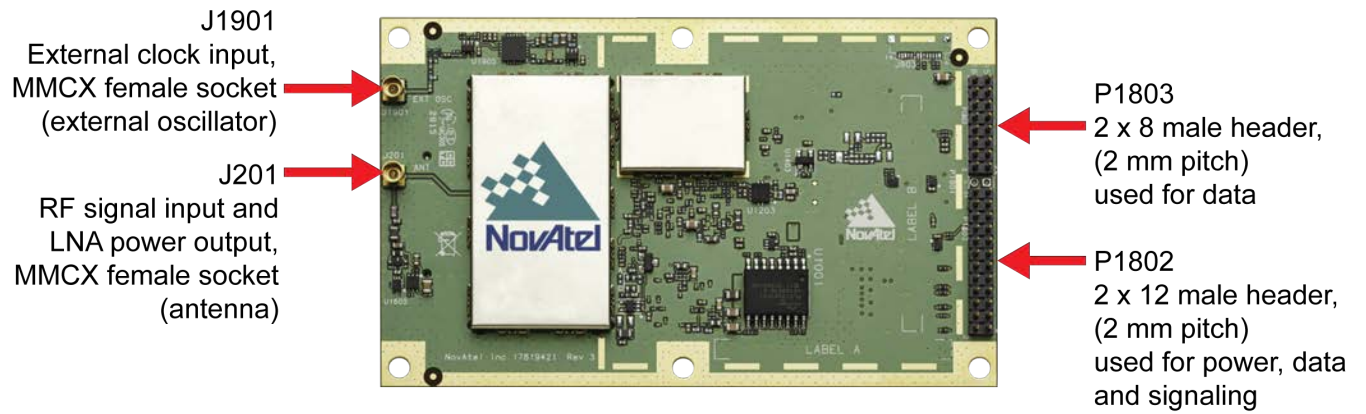

Figure 14: OEM729 Connector and Indicator Locations

Top View



Bottom View

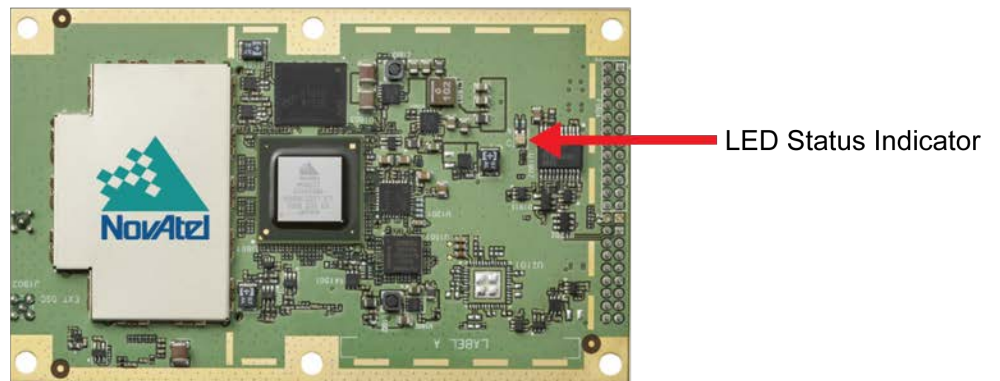

Figure 15: OEM7600 Connector and Indicator Locations

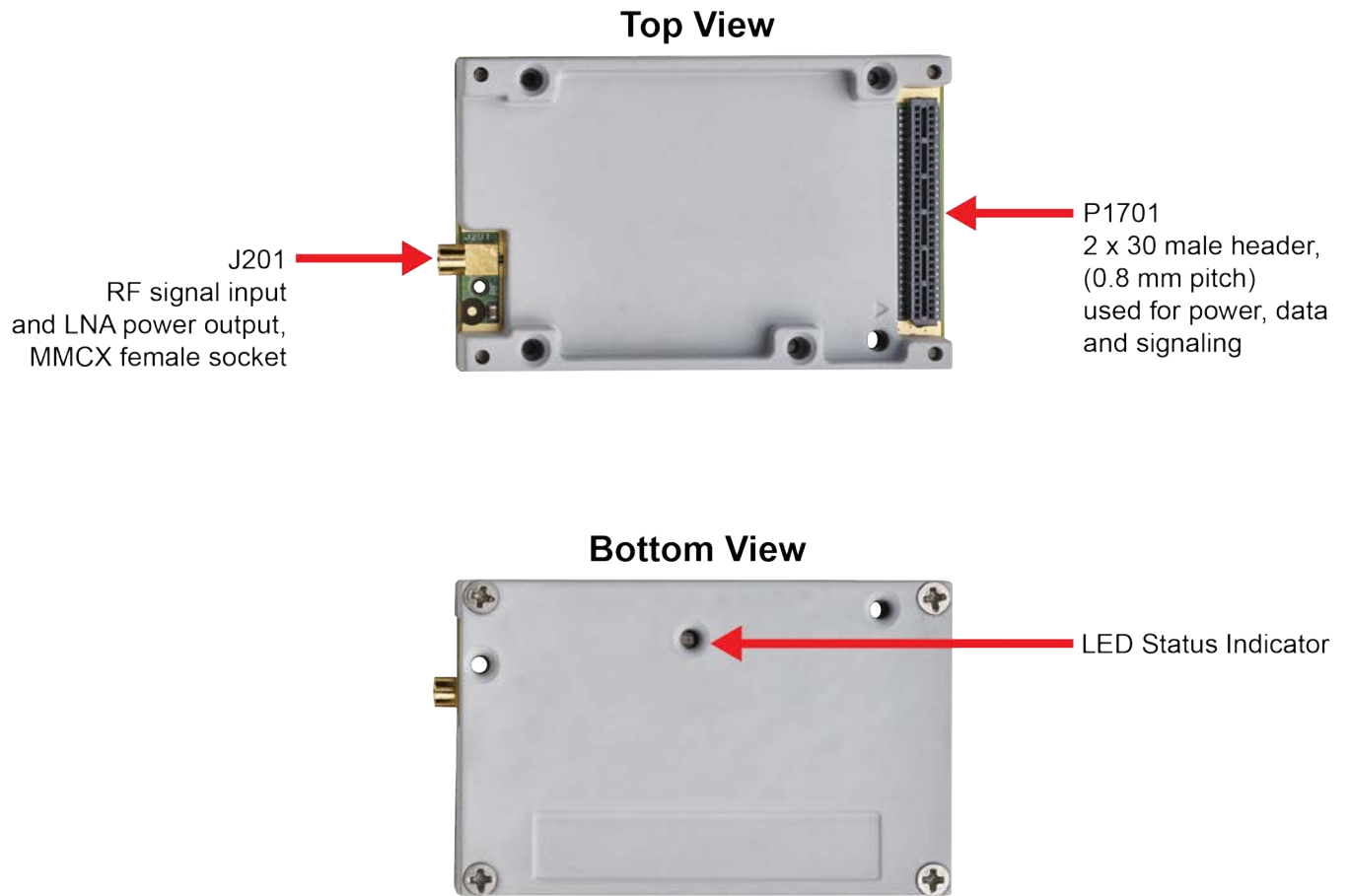

Figure 16: OEM7700 Connector and Indicator Locations

Top View



Bottom View

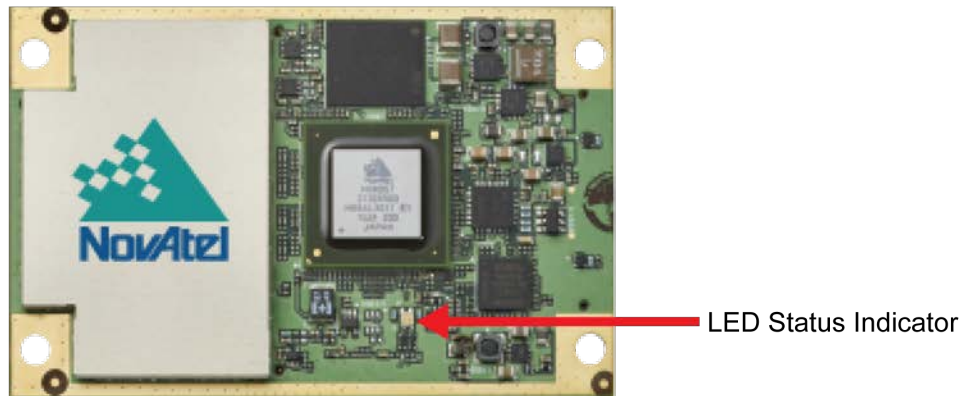
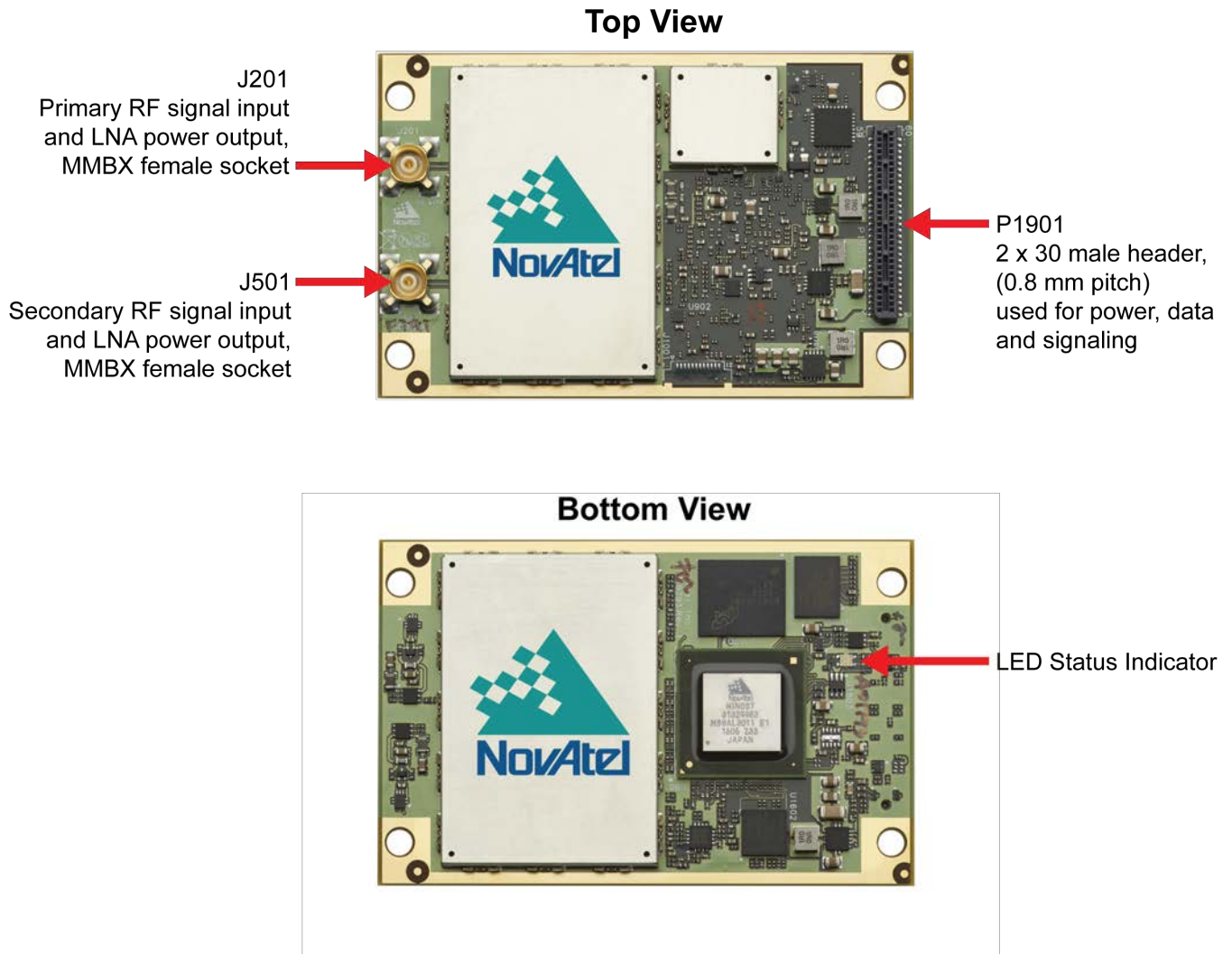

Figure 17: OEM7720 Connector and Indicator Locations



Many of the OEM7 communication and I/O signals are provided at LVCMOS levels and may need interface circuits to communicate with other devices. See *Receiver Card Interface Examples* on page 240 for examples of these interface circuits.

2.8 Mounting the GNSS Antenna

The OEM7 receiver is designed to operate with any NovAtel GNSS antenna. See *Selecting a GNSS Antenna* on page 29 for more information.

When installing the antenna:

- Choose an antenna location with a clear view of the sky so each satellite above the horizon can be tracked without obstruction. For more information on RF signal propagation and multipath, refer to the NovAtel application note [APN-008: Discussions on RF Signal Propagation and Multipath](http://novatel.com/support/support-materials/application-notes) at novatel.com/support/support-materials/application-notes.

- Mount the antenna on a secure, stable structure capable of safe operation in the specific environment.
- Ensure the antenna cannot move due to dynamics.
- For dual antenna systems only
Heading accuracy is dependent on antenna baseline length. Mount the primary and secondary antennas as far apart as possible. A minimum separation distance of 1 metre is recommended.

For more detailed information about GNSS antenna installation, refer to [APN-077: RF Equipment Selection and Installation](https://www.novatel.com/support/support-materials/application-notes) at [novatel.com/support/support-materials/application-notes](https://www.novatel.com/support/support-materials/application-notes).

2.9 Connecting the Antenna to the Receiver Card

An interconnect adapter cable is required to convert the end of the antenna coaxial cable to the RF input connector on the OEM7 receiver.

Table 3: OEM7 Antenna Connectors

Receiver	Primary Antenna Connector	Secondary Antenna Connector	External Oscillator
OEM719	MCX ¹	N/A	N/A
OEM729	MMCX	N/A	MMCX
OEM7600	MMCX (right angle)	N/A	N/A
OEM7700	MMBX	N/A	N/A
OEM7720	MMBX	MMBX	N/A

For the location of the antenna connector on the receiver card, see *Figure 13: OEM719 Connector and Indicator Locations* on page 41, *Figure 14: OEM729 Connector and Indicator Locations* on page 42, *Figure 15: OEM7600 Connector and Indicator Locations* on page 43, *Figure 16: OEM7700 Connector and Indicator Locations* on page 44 or *Figure 17: OEM7720 Connector and Indicator Locations* on the previous page.



NovAtel generally uses the MMBX connectors with barrels for board-to-board mounting. These connectors allow a blind mate and are able to move slightly under vibration to reduce the potential for damage to either PCB. The mating connector on the interface PCB must be a Huber and Suhner 82_MMBX-S50-0-1/111 NE or similar.

The MMBX antenna connector can also be connected directly to a cable. For information about MMBX to cable solutions, contact Customer Support to obtain the *OEM7 Receiver Card Mechanical Integration Application Note* (D19021).

Receiver	Antenna Connector	Barrel for Board to Board Mounting
OEM7700 and OEM7720	HUBER + SUHNER MMBX Straight PCB jack Commercial PN: 82_MMBX-S50-0-1/111 NE	HUBER + SUHNER MMBX plug (male) / MMBX plug (male) 10 mm. (other sizes are available) Commercial PN: 32_MMBX-50-0-4/111_NE

¹The OEM719A uses a right angle MCX connector.
The OEM719B uses an MMBX connector.

2.9.1 Antenna LNA Power

NovAtel antennas and coaxial cables meet receiver RF input gain requirements. NovAtel coaxial cables are designed to introduce no more than 10 dB loss and NovAtel antennas are equipped with built-in LNAs that provide 29 dB of gain to the satellite signal received.

The power to the antenna LNA is provided through the receiver's RF port center conductor.

OEM7 receivers, except the OEM7600, provide +5 VDC \pm 5% at a maximum of 200 mA. The OEM7600 provides +3.3 VDC \pm 5% at a maximum of 100 mA.

Antenna supply over current protection limits the LNA power.



If a short circuit or other problem causes an overload of the current supplied to the antenna, the receiver hardware shuts down the power supplied to the antenna. To restore power, power cycle the receiver. The Receiver Status word, available in the **RXSTATUS** log (see [OEM7 Commands and Logs Reference Manual](#)), provides more information about the cause of the problem.

2.10 Applying Power to the Receiver Card

Ensure the power supply is providing the voltage indicated in *Power Supply Requirements for Receiver Cards* on page 30, then connect the power supply to the receiver card interface.

2.11 Connecting Data Communications Equipment

OEM7 receivers communicate with other devices in the system using:

- *Serial Ports* below
- *USB Ports* on page 51
- *Ethernet Ports* on page 52
- *SPI Ports* on page 53

2.11.1 Serial Ports

The serial communication ports (COM ports) are used to communicate between components in the GNSS system and to external data communications equipment such as computers and data loggers.

Table 4: OEM7 Card Default Serial Port Configurations

Model	COM1	COM2	COM3	COM4	COM5
OEM719	LVC MOS no flow control	LVC MOS no flow control	LVC MOS no flow control	N/A	N/A
OEM729	User configurable as - RS-232 with flow control - RS-422 without flow control	LVC MOS with flow control	LVC MOS no flow control	N/A	N/A

Model	COM1	COM2	COM3	COM4	COM5
OEM7600	LVC MOS with flow control	LVC MOS with flow control	LVC MOS no flow control	LVC MOS no flow control	LVC MOS no flow control
OEM7700	LVC MOS with flow control	LVC MOS with flow control	LVC MOS no flow control	LVC MOS no flow control	LVC MOS no flow control
OEM7720	LVC MOS with flow control	LVC MOS with flow control	LVC MOS no flow control	LVC MOS no flow control	LVC MOS no flow control



On the OEM729, COM1 can be user configured for RS-232 or RS-422 operation. Refer to *Serial Port Communications* on page 56 for instructions.



Hardware flow control (handshaking) is enabled and disabled using the **SERIALCONFIG** command.

Each port may support some or all of the following signals:

- Transmitted Data (TX)
- Received Data (RX)
- Request To Send (RTS) [ports with flow control]
- Clear To Send (CTS) [ports with flow control]

Port settings (bit rate and parity, for example) are software configurable. See *Communications with the Receiver* on page 55. Also see *OEM719 Technical Specifications* on page 134, *OEM729 Technical Specifications* on page 154, *OEM7600 Technical Specifications* on page 174, *OEM7700 Technical Specifications* on page 195 and *OEM7720 Technical Specifications* on page 217 for further information on data communications specifications and pin assignments.

OEM719 Multiplexed Port

On the OEM719, COM3 is multiplexed with USB and EVENT1. USB and EVENT1 are enabled by default.

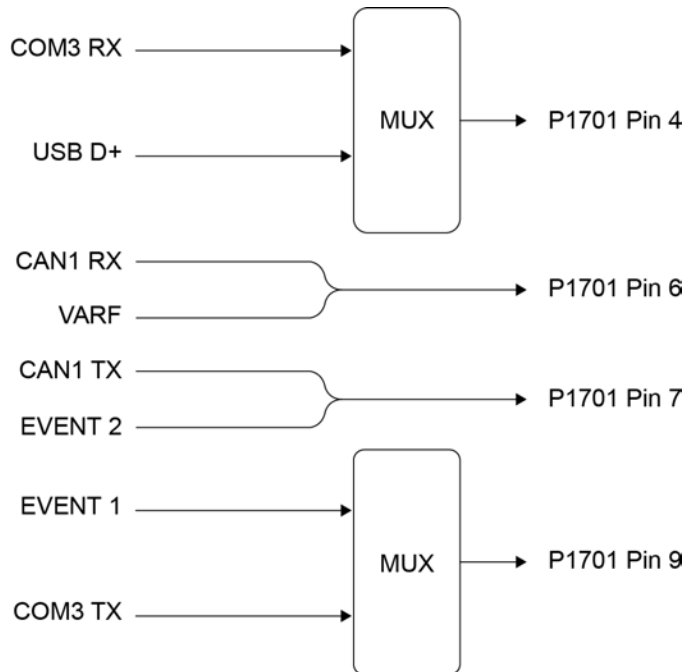
Figure 18: COM3 and USB Multiplexed on OEM719

To enable COM3, issue the following commands:

1. **INTERFACEMODE USB1 NONE NONE**
2. **INTERFACEMODE USB2 NONE NONE**
3. **INTERFACEMODE USB3 NONE NONE**
4. **EVENTINCONTROL MARK1 DISABLE**
5. **INTERFACEMODE COM3 NOVATEL NOVATEL**
6. **SAVECONFIG** (optional)

To enable USB, issue the following commands:

1. **INTERFACEMODE COM3 NONE NONE**
2. **INTERFACEMODE USB1 NOVATEL NOVATEL**
3. **INTERFACEMODE USB2 NOVATEL NOVATEL**
4. **INTERFACEMODE USB3 NOVATEL NOVATEL**
5. **SAVECONFIG** (optional)

To enable EVENT1, issue the following commands:

1. **INTERFACEMODE COM3 NONE NONE**
2. **EVENTINCONTROL MARK1 ENABLE**
3. **SAVECONFIG** (optional)

OEM729 RS-422 Port

On the OEM729 card, COM1 can be configured as either RS-232 (optionally with hardware flow control, if the cable used supports it) or RS-422 (with no hardware flow control), by setting pin 2 of P1802 (USER1) LOW or

HIGH respectively at boot time.



The OEM729 receiver samples pin 2 during the boot sequence to determine the mode for COM1.

By default, RS-232 is selected since the pin 2 input, if open, is pulled LOW by an internal pull down resistor. To select RS-422, pull pin 2 of P1802 to 3.3 VDC during start-up.



Do not apply 3.3 VDC directly to pin 2. NovAtel recommends using a 1 kΩ resistor to pull pin 2 high.

See *OEM729 Interface Connectors* on page 167 for pin-out details for COM1 RS-232 and RS-422 configurations.

OEM729 Multiplexed Port

A third serial port, COM3, is also available on pin 7 (RXD) and pin 19 (TXD). By default, COM3 is enabled. COM3 is multiplexed with both EVENT2 and USER0.

Figure 19: OEM729 COM3 Multiplexed with EVENT2 and USERGPIO

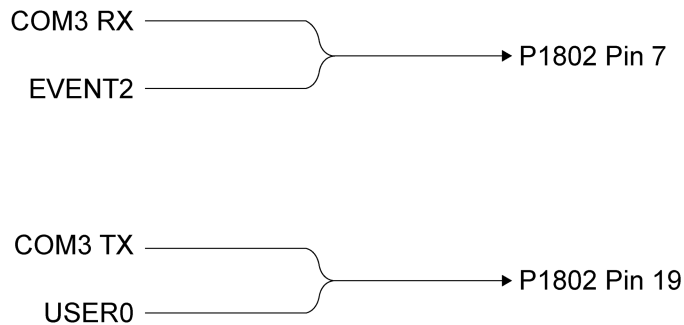

To enable COM3:

1. If a user application is running, make sure it does not initialize GPIO_USER0.
2. Issue the following command: **EVENTINCONTROL MARK2 DISABLE**
3. Issue the following command: **INTERFACEMODE COM3 NOVATEL NOVATEL ON**
Use any interface mode except **NONE**

To enable MARK2:

1. Issue the following command: **EVENTINCONTROL MARK2 ENABLE**
2. Issue the following command: **INTERFACEMODE COM3 NONE NONE OFF**

OEM7600, OEM7700 and OEM7720 Multiplexed Port

Flow control (RTS and CTS) for COM2 is optionally available on the COM5 pins (pins 5 and 11) of the interface connector.

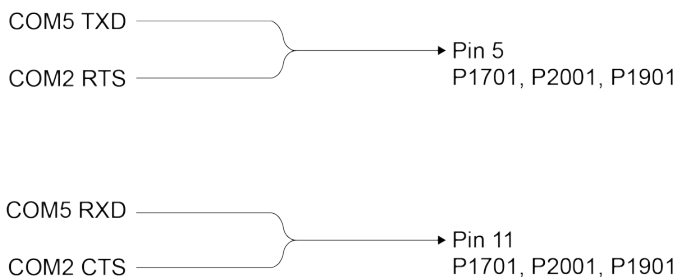
Figure 20: COM5 Multiplexed with COM2 Flow Control

To enable flow control for COM2:

1. Issue the following command: **INTERFACEMODE COM5 NONE NONE OFF**
2. Issue the following command: **SERIALCONFIG COM2 115200 N 8 1 CTS ON**

To enable COM5:

1. Issue the following command: **SERIALCONFIG COM2 115200 N 8 1 N ON**
2. Issue the following command: **INTERFACEMODE COM5 NOVATEL NOVATEL ON**
Use any interface mode except **NONE**

Refer to the [OEM7 Commands and Logs Reference Manual](#) for further command information.

2.11.2 USB Ports

OEM7 receivers have USB 2.0 compatible ports. The number of ports, bit rate and modes available vary depending on the receiver.

Table 5: Available USB Ports

Receiver	Number of Ports	Port Bit Rate	Mode	USB Signals
OEM719	1	12 Mbps	Device only	Pin 3 D(-) and Pin 4 D(+) on P1701 (main header). Pin 4 is multiplexed with COM3
OEM729	1	12 Mbps	Device only	Pin 21 D(-) and Pin 22 D(+) of P1802 (24-pin header)
OEM7600	2	480 Mbps	1 Device and 1 Host	USB0: Pin 48 D(+) and Pin 50 D(-) on P1701 USB1: Pin 47 D(-) and Pin 49 D(+) on P1701
OEM7700	2	480 Mbps	1 Device and 1 Host	USB0: Pin 48 D(+) and Pin 50 D(-) on P2001 USB1: Pin 47 D(-) and Pin 49 D(+) on P2001
OEM7720	2	480 Mbps	1 Device and 1 Host	USB0: Pin 48 D(+) and Pin 50 D(-) on P1901 USB1: Pin 47 D(-) and Pin 49 D(+) on P1901

See *OEM719 Technical Specifications* on page 134, *OEM729 Technical Specifications* on page 154, *OEM7600 Technical Specifications* on page 174, *OEM7700 Technical Specifications* on page 195 and

OEM7720 Technical Specifications on page 217 for further information on USB specifications and pin assignments.

If the USB port is being routed to an external device, ESD protection is needed. For an example of a USB interface circuit, see *USB Interface* on page 246.

USB Modes

The USB mode of a port (Device or Host) is set by the state of the UID pin. See *OEM7600 Interface Connector* on page 185, *OEM7700 Interface Connector* on page 207 and *OEM7720 Interface Connector* on page 230 for more information.

When a USB port is set to Device mode, it is used to communicate between components in the GNSS system and to external data communications equipment such as computers and data loggers.

When the USB port is set to Host mode, it supports USB mass storage devices, such as USB memory sticks.



For information about the USB memory sticks supported by OEM7 receivers, see *USB Devices Supported* on page 257.

Multiple USB Ports

OEM7 receivers with a 60 pin interface connector (such as the OEM7700) have two USB ports, one configured as a device and one configured as a host.

The state of the USB Port Mode Select pin (pin 51) determines which USB port is configured as host.

Table 6: USB Port Mode

USB Port Mode Select Pin (UID) State	USB0 Mode	USB1 Mode
Tied Low	Host	Device
Tied High Left Unconnected	Device	Host

USB0 is the recommended interface if only one of the USB ports is used, as USB0 provides a connection for VBUS.

USB OTG is not supported. The state of the USB Port Mode Select pin is sampled when the receiver starts and the USB mode of both ports is set at that time.

2.11.3 Ethernet Ports

OEM7 receivers have a 10Base-T/100Base-TX Ethernet port for communications with external data communications equipment such as computers and data loggers. The Ethernet port supports IPv4 Internet layer, TCP/IP transport and telnet. Users can conduct remote debugging, accept MRTCA (modified RTCA) data and download firmware. OEM7 receivers are also equipped with NTRIP Version 2.0 (Networked Transport of RTCM via Internet Protocol) client and server capability.



The OEM7 receiver cards do not have Ethernet magnetics or an RJ45 connector. If using the OEM7 Ethernet connectivity, the distance between the OEM7 receiver and the magnetics must be no more than 10 inches (25.4 cm), and the distance between the magnetics and the jack must be no more than 1.5 inches (3.8 cm).

The OEM7 uses the Texas Instruments TKL106 Ethernet PHY. Follow Texas Instruments' recommendations for transformer selection.

If the Ethernet port is being routed outside of the enclosure, an interface circuit is needed. For an example of an Ethernet interface circuit, see *Ethernet Port* on page 249.

See *OEM729 Technical Specifications* on page 154, *OEM7600 Technical Specifications* on page 174, *OEM7700 Technical Specifications* on page 195 and *OEM7720 Technical Specifications* on page 217 for further information on Ethernet specifications and pin assignments.



Ethernet is not available on OEM719 receivers.

Refer to *Ethernet Configuration* on page 90 for instructions on configuring Ethernet and NTRIP.

2.11.4 SPI Ports

The Serial Peripheral Interface (SPI) port provides communications to specific, supported devices in the GNSS system. The OEM7 functions as a SPI host and cannot be interfaced as a SPI Device. For example, the OEM7 receiver can use the SPI port to communicate with some IMUs in a SPAN system. Here is a list of the currently supported devices:

- OEM-IMU-ADIS-16488
- OEM-IMU-EG320N
- OEM-IMU-EG370N



A SPI port is only available on OEM7500, OEM7600, OEM7700 and OEM7720 receivers.

2.12 Check that the Receiver is Operating

After the receiver is installed, powered up and connected to a GNSS antenna, use the following procedure to ensure the receiver is operating.

1. Check the LED Status Indicator is blinking green at 1 Hz.

See *Preparing the Data, Signal and Power Interface* on page 39 for the location of the LED.

2. Connect the receiver to a computer using a serial or USB cable.
3. Open **NovAtel Application Suite**, establish a connection to the receiver and open the *Terminal* window. Alternately, open a terminal emulation program and establish a connection to the receiver.



For information about installing and using NovAtel Application Suite, refer to docs.novatel.com/Tools/Content/ToolsSuite/Overview.htm.

4. Send the following command:

LOG VERSION

The VERSION log is returned.

```
<VERSION COM1 0 85.5 FINESTEERING 1889 332680.442 02040020 3681 13662
2
GPSCARD "FFNRNNTBNS3" "DMGW16080031A" "OEM719-1.01"
"OM7MR0000RN0000" "OM7BR0000RB0000" "2015/DEC/14" "19:23:28"
OEM7FPGA "" "" "" "OMV070001RN0000" "" "" ""
```

5. Check that the Time Status is **FINESTEERING** which represents that time is fine set and being steered.
6. Check the Receiver Status word (02040020 in this example). If the lowest bit (bit 0) is set, the receiver has errors.



For information about the other digits in Receiver Status word, refer to the **RXSTATUS** log in the [OEM7 Commands and Logs Reference Manual](#).



It can take about a minute for time status to reach **FINESTEERING** depending on number of satellites being tracked. This assumes the antenna is located in an open sky environment and the RF set up meets the requirements.

Chapter 3 OEM7 Receiver Operation

Before operating the receiver for the first time, use the installation instructions in *OEM7 Family Receiver Cards Installation* on page 29. The following instructions are based on a configuration similar to the following figure.

Figure 21: Basic OEM7 Receiver Connection Interfaces (example)

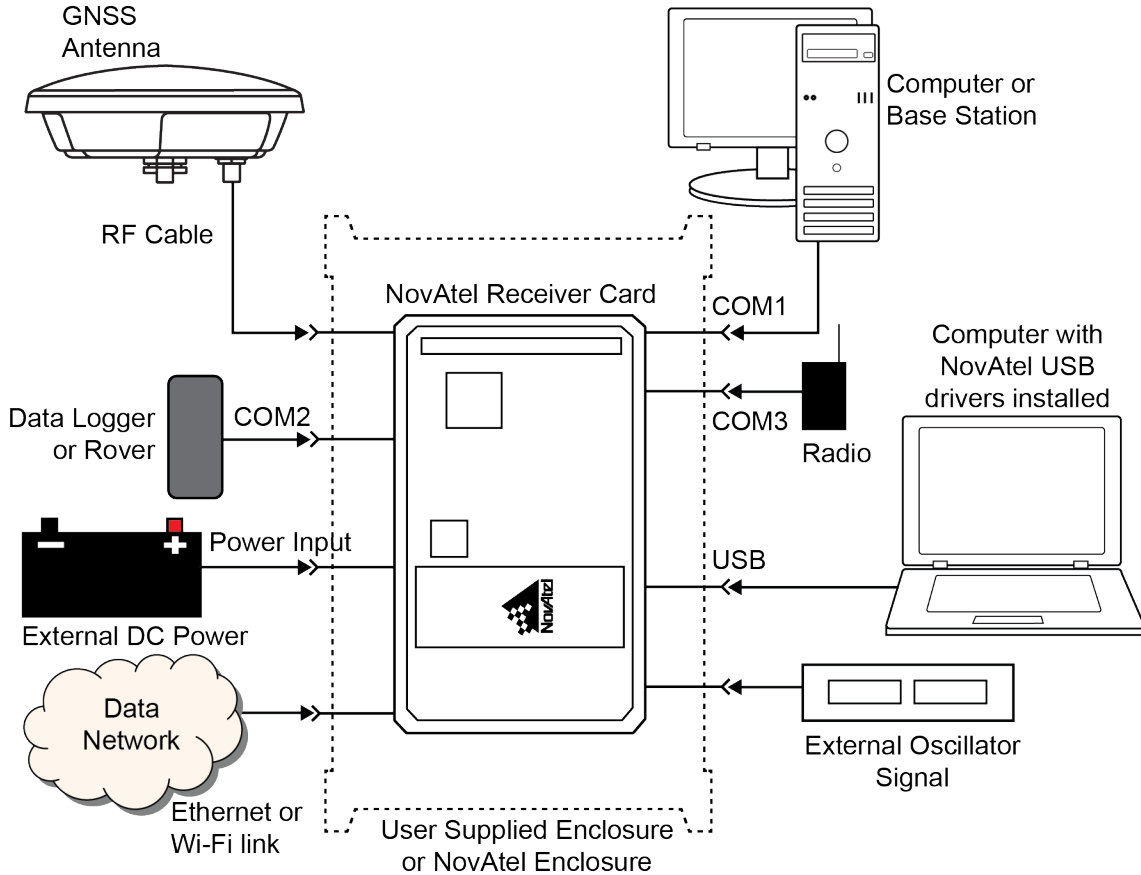

The figure above does not show all necessary hardware. Also see *Figure 22: Basic Differential Setup* on page 61 for a base/rover example.



The optional External Oscillator Signal option is only available on the OEM729.



The COM ports on OEM7 receiver cards are LVCMOS, except COM1 on the OEM729, and signal conversion may be required depending on the equipment connected.

3.1 Communications with the Receiver

Communication is established with the receiver using a data terminal or computer connected to the receiver by a variety of methods:

- *USB Communications* below
- *Serial Port Communications* below
- *Ethernet Communications* on page 58
- *ICOM Communications* on page 59
- *CAN Bus Communications* on page 59

When connected to the receiver, enter commands directly from a terminal or through terminal emulation software on a computer. For example:

- **NovAtel Setup & Monitor (Web)** - NovAtel Setup & Monitor (Web) is a browser based tool used to monitor, configure and update a variety of receiver functions. For information about using Setup & Monitor (Web), refer to the online documentation (docs.novatel.com/Tools).
- **NovAtel Application Suite** - NovAtel Application Suite is set of computer based applications that simplify the configuration and monitoring of NovAtel receivers. For information about installing and using NovAtel Application Suite, refer to the online documentation (docs.novatel.com/Tools).
- Any console/command line application

To maximize the application of the receiver's capabilities, become familiar with the commands and logs described in the [OEM7 Commands and Logs Reference Manual](#).

3.1.1 USB Communications

To communicate between an OEM7 receiver and a computer using a USB port, NovAtel USB drivers must be installed on the computer. These USB drivers are available on the NovAtel website at novatel.com/support/support-materials/software-downloads.

USB Drivers

NovAtel USB drivers for OEM7 receivers are available for Windows 7, Window 8, Windows 10 and Linux.

The NovAtel USB drivers provide three virtual serial ports over a single USB 2.0 connection. The three virtual serial ports are available to existing Windows or Linux applications which use COM ports to communicate (for example, NovAtel Application Suite). The NovAtel USB drivers assign COM port numbers sequentially following any existing ports on the computer. For example, if a computer has COM1 and COM2 ports, the NovAtel USB drivers assign COM3 to USB1, COM4 to USB2 and COM5 to USB3.



USB communications are not suitable for use in vehicles.



A computer has several USB ports. The assignment of COM port numbers is tied to a USB port on the computer. This allows receivers to be switched without Microsoft Windows assigning new COM ports. However, if the receiver is connected to a different physical USB port, Windows detects the receiver's presence and assigns three new COM port numbers.

3.1.2 Serial Port Communications

The receiver can communicate with a computer or terminal via a serial port. For communication to occur, both the receiver and the operator interface have to be configured properly. The receiver's default port settings are:

- 9600 bps
- no parity

- 8 data bits
- 1 stop bit
- no handshaking
- echo off
- break on

The data transfer rate determines how fast information is transmitted. Take for example a log whose message byte count is 96. The default port settings allows 10 bits/byte (8 data bits + 1 stop bit + 1 framing bit). It therefore takes 960 bits per message. To get 10 messages per second then requires 9600 bps. Also remember that even if you set the bps to 9600, the actual data transfer rate may be lower and depends on the number of satellites being tracked, data filters in use, and idle time. It is therefore suggested that you leave yourself a margin when choosing a data rate.



The minimum suggested baud rate for most applications is 115200 bps for GNSS only or 230400 bps for GNSS+INS. If the buffer overrun flag is present in the **RXSTATUS** log (refer to the [OEM7 Commands and Logs Reference Manual](#)), log at a higher baud rate if possible, or change to a medium supporting higher bandwidth (USB or Ethernet).



Although the receiver can operate at data transfer rates as low as 300 bps, this is not recommended. For example, if several data logs are active (that is, a significant amount of information needs to be transmitted every second) but the bit rate is set too low, data overflows the serial port buffers, causing an error condition in the receiver status that results in lost data.



Refer to *Serial Ports* on page 47 for additional default setting details.

The following ports are supported and can be configured using the commands listed. Refer to the commands listed in the [OEM7 Commands and Logs Reference Manual](#) for detailed instructions.

Table 7: Serial Ports Supported

Receiver Type	Port Supported	Configuration Command
OEM719	COM1, COM2, COM3	SERIALCONFIG
OEM729	COM1, COM2, COM3	SERIALCONFIG and SERIALPROTOCOL
OEM7600	COM1, COM2, COM3, COM4, COM5	SERIALCONFIG
OEM7700	COM1, COM2, COM3, COM4, COM5	SERIALCONFIG
OEM7720	COM1, COM2, COM3, COM4, COM5	SERIALCONFIG

Change the COM Port Settings

To change the settings on a COM port, use the **SERIALCONFIG** command. For example:

- To change the data rate of COM2 to 115200, enter:

```
SERIALCONFIG COM2 115200
```

- To change the data rate of COM1 to 57600 and enable even parity, enter:

```
SERIALCONFIG COM1 57600 E
```

Configure a COM Port to Use RS-232 or RS-422

COM1 of the OEM729 communicates using RS-232 protocol by default, but can be configured to use RS-422 protocol.

The **SERIALPROTOCOL** command is used to select RS-232 or RS-422 for the COM port.

Commands are executed after the receiver has completed booting so the communication lines may be configured incorrectly during the time taken to boot and before the command can be processed. For automatic configuration, the **SERIALPROTOCOL** command can be saved using the **SAVECONFIG** command.



After switching a COM port from RS-232 to RS-422, send a carriage return (CR) on the newly configured port to flush the buffer prior to sending new commands on the port.

Communicating using a Remote Terminal

One method of communicating with the receiver is through a remote terminal. To communicate with the terminal, the receiver requires only the RX, TX and GND lines be used. Handshaking is not required but is an option. Ensure the terminal's communications set up matches the receiver's port settings.



COM ports on OEM7 receivers cards use LVCMOS voltage levels and require an interface circuit to communicate with a remote terminal. The exception is COM1 on the OEM729 that uses RS-232 voltage levels and can interface directly to a remote terminal.

Communicating using a Computer

A computer can emulate a remote terminal as well as provide the added flexibility of supporting multiple command batch files and data logging storage files. Use any standard communications software package that emulates a terminal to establish bidirectional communications with the receiver. Examples include NovAtel Application Suite and PuTTY. All data is sent as raw 8-bit binary or ASCII characters.

Refer to *Communicating with the Receiver* on page 60 for details.



COM ports on OEM7 receivers cards use LVCMOS voltage levels and require an interface circuit to communicate with a computer. The exception is COM1 on the OEM729 that uses RS-232 voltage levels and can interface directly to a computer.

3.1.3 Ethernet Communications

OEM7 receivers, except the OEM719, are equipped with a 10-Base-T/100-Base-TX Ethernet port that supports IPv4 Internet layer, TCP/IP transport and telnet. Users can conduct remote debugging, accept MRTCA (modified RTCA) data and update firmware. OEM7 receivers are also equipped with NTRIP Version 2.0 (Networked Transport of RTCM via Internet Protocol) client and server capability.

The Ethernet port must be configured before using. Refer to *Ethernet Configuration* on page 90 for configuration details.



The Ethernet ports are Safety Extra-Low Voltage (SELV) circuits only and are suitable for connection within a building only. Do not connect them to Telephone Network Voltage (TNV) circuits. If intra-building connections are required, or the OEM7 receiver is installed in an outdoor enclosure, a suitably rated Ethernet router or switch should be installed between the receiver Ethernet port and the network connection.



Issue the **SAVEETHERNETDATA ETHA** command to ensure port settings are retained after a reset and automatically used at boot time. The **SAVEETHERNETDATA ETHA** command is not applicable to the **ICOMCONFIG** and **NTRIPCONFIG** command settings. The **SAVEETHERNETDATA ETHA** command takes precedence over the **SAVECONFIG** command configuration.

3.1.4 ICOM Communications

ICOM ports are virtual ports used for Ethernet connections. The transport/application layer of the ICOM ports can be configured to use Transmission Control Protocol (TCP) for internet IP or User Datagram Protocol (UDP) a slower and less reliable IP protocol.

Refer to **DNSCONFIG** command for Ethernet DNS configuration. If using DHCP, DNS is automatically set.

The following are the default ICOM configurations:

- ICOMCONFIG ICOM1 TCP :3001
- ICOMCONFIG ICOM2 TCP :3002
- ICOMCONFIG ICOM3 TCP :3003
- ICOMCONFIG ICOM4 TCP :3004
- ICOMCONFIG ICOM5 TCP :3005
- ICOMCONFIG ICOM6 TCP :3006
- ICOMCONFIG ICOM7 TCP :3007

Each ICOM port can act as a server (waiting for an external connection to be made) or as a client (actively establishing a connection to a specific port).

For details on the ICOM port commands, refer to **IPCONFIG** command, **ICOMCONFIG** command and **ETHCONFIG** command in the [OEM7 Commands and Logs Reference Manual](#).

3.1.5 CAN Bus Communications

The OEM7 receiver supports J1939 and NMEA2000 CAN protocols.

OEM7 receiver cards, except the OEM7500, have two CAN ports. The OEM7500 has one CAN port. These CAN ports support data rates up to 1 Mbps.

Proper bus termination is required.

Refer to *CAN Bus* on page 98 for detailed instructions.

3.2 Getting Started

The receiver's software resides in flash memory. When first powered, it undergoes a complete self-test. If an error condition is detected during the self-test, the status word changes. This self-test status word can be viewed in the header of any data output log. Refer to Messages in the [OEM7 Commands and Logs Reference Manual](#) for header information. If a persistent error occurs, contact your local NovAtel dealer. If the dealer

cannot resolve the problem, contact NovAtel Customer Support directly using one of the methods listed in *Customer Support* on page 17.



Power to the card must be applied for >150 ms before any of the external interfaces are powered on by the integrator's card.

3.2.1 Communicating with the Receiver

You can communicate with the receiver using NovAtel Setup & Monitor (Web), NovAtel Application Suite or a terminal emulation program.



For instructions on using NovAtel Setup & Monitor (Web) and NovAtel Application Suite, refer to docs.novatel.com/Tools.

When the receiver is first turned on, no data is transmitted from the COM ports except for the port prompt.

Any of the COM port prompts indicate that the receiver is ready and waiting for command input. The screen may display other port names for other port types.



1. Output from receiver self-tests may take some time. On startup, the receiver is set to log the RXSTATUSEVENTA log ONNEW on all ports. See *RXSTATUSEVENT Log* on page 86 for more details.
2. If NovAtel Application Suite is unable to locate the receiver, use a different COM port to communicate with the receiver. When communication has been established, issue a **FRESET STANDARD** command. The original communications port should be ready for use. See the **FRESET** command for more information.

An example of a response to an input **LOG** command:

```
[COM2] LOG COM1 BESTPOS ONTIME 1
<OK
```

In this example, [COM2] is the port prompt.

If the command was accepted, the receiver responds with:

```
<OK
```

If a command is entered incorrectly, the receiver responds with:

```
<ERROR:Invalid Message ID (or a more detailed message)
```



Ensure the computer does not sleep or hibernate during a logging session or data will be lost.

3.3 Transmitting and Receiving Corrections

Corrections can be transmitted from a base station to a rover station to improve position accuracy. The base station is the GNSS receiver that acts as the stationary reference. The stationary reference has a known position and transmits correction messages to the rover station. The rover station is the GNSS receiver that does not know its exact position and requires correction messages from a base station to calculate differential GNSS positions. An example of a differential setup is shown in *Figure 22: Basic Differential Setup* below.

Figure 22: Basic Differential Setup

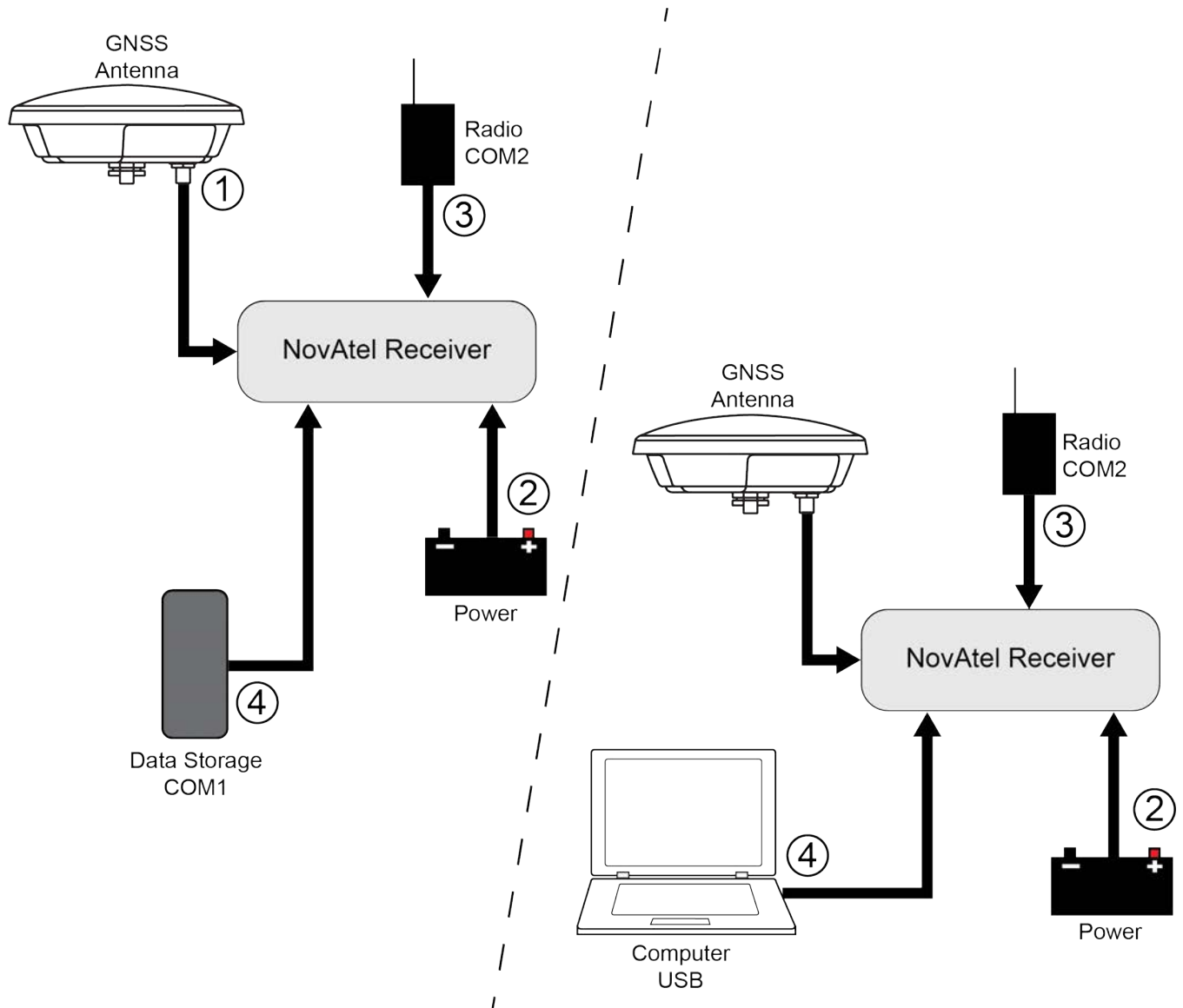
**Rover Setup**

- 1 Mount and connect a GNSS antenna
- 2 Connect a fused power supply (user supplied)
- 3 Connect a radio device to COM2 (user supplied)
- 4 Connect a storage device to COM1 (user supplied)

Base Setup

- 1 Mount and connect a GNSS antenna
- 2 Connect a fused power supply (user supplied)
- 3 Connect a radio device to COM2 (user supplied)
- 4 Connect a computer to COM1 for setup and monitoring (user supplied)

To receive corrections, a data link between the base station and the rover station is required. The base and rover stations can both be NovAtel receivers, however NovAtel receivers will work with some other brands. Contact Customer Support for further details (refer to *Customer Support* on page 17 for details).

The data link should support a rate of at least 19200 bits per second, but a rate of 115200 bits per second, with less than 4.0 s latency, is recommended.



Unlike the base/rover concept, SBAS and PPP corrections can be applied directly to a single receiver.

When the base and rover are set up, configure them as shown in the configuration examples in *Base Station Configuration* below and *Rover Station Configuration* on the next page.

3.3.1 Defining Antenna and Base Antenna

The type of antenna for the receiver and/or the base receiver can be defined using the **THISANTENNA** command and **BASEANTENNA** command respectively.

The Phase Center Variation (PCV) and the Phase Center Offset (PCO) for each can also be specified using the **THISANTENNA** command and **THISANTENNA** command or the **BASEANTENNA** command and **BASEANTENNA** command.

Refer to the [OEM7 Commands and Logs Reference Manual](#) for command details.

3.3.2 Base Station Configuration

At the base station, enter the following commands:

```
serialconfig [port] baud [parity[databits[stopbits[handshaking[break]]]]]
interfacemode port rx_type tx_type [responses]
fix position latitude longitude height (enter your own lat, lon and hgt values)
log port message [trigger [period]] (port = COM2 / refer to Figure 22: Basic Differential Setup on the previous page)
saveconfig (optional)
```

The following sections are examples of base station configurations.

RTK Automated Correction Generation

```
fix position lat lon hgt (enter your own lat, lon, hgt)
generatertkcorrections rtkmv3 com2
```

RTCM V3

```
serialconfig com2 19200 N 8 1 N on
interfacemode com2 none rtkmv3 off
fix position lat lon hgt (enter your own lat, lon, hgt)
log com2 rtkmv3 ontime 1
log com2 rtkmv3 ontime 10
log com2 rtkmv3 ontime 120
saveconfig (optional)
```

RTCM V3 with GLONASS

```
serialconfig com2 19200 N 8 1 N on
interfacemode com2 none rtkmv3 off
fix position lat lon hgt (enter your own lat, lon, hgt)
log com2 rtkmv3 ontime 1
```

```
log com2 rtcml012 ontime 1
log com2 rtcml006 ontime 10
log com2 rtcml033 ontime 10
log com2 rtcml019 ontime 120
log com2 rtcml020 ontime 120
saveconfig (optional)
```

NOVATELX

```
serialconfig com2 19200 N 8 1 N on
interfacemode com2 none novatelx off
fix position lat lon hgt (enter your own lat, lon, hgt)
log com2 novatelxobs ontime 1
saveconfig (optional)
```



For more information, refer to the **FIX** command, **INTERFACEMODE** command, **SAVECONFIG** command and **SERIALCONFIG** command in the [OEM7 Commands and Logs Reference Manual](#).

3.3.3 Rover Station Configuration

At the rover station, enter the following commands:

```
serialconfig [port] baud [parity[ databits [stopbits [handshaking [break]]]]]
interfacemode port rx_type tx_type [responses]
saveconfig (optional)
```

The following sections are examples of rover configurations, if COM2 was connected to the correction source.

RTK Automated Correction Detection

```
serialconfig com2 19200 N 8 1 N on
interfacemode com2 auto none off
saveconfig (optional)
```

RTCM V3

```
serialconfig com2 19200 N 8 1 N on
interfacemode com2 rtcmv3 none off
saveconfig (optional)
```

RTCM V3 with GLONASS

```
serialconfig com2 19200 N 8 1 N on
interfacemode com2 rtcmv3 none off
saveconfig (optional)
```

NOVATELX

```
serialconfig com2 19200 N 8 1 N on
interfacemode com2 NOVATELX none off
saveconfig (optional)
```



For more information, refer to the **INTERFACEMODE** command, **SAVECONFIG** command and **SERIALCONFIG** command in the [OEM7 Commands and Logs Reference Manual](#).

3.3.4 Configuration Notes

For compatibility with other GNSS receivers and to minimize message size, use the standard form of RTCMV3 corrections shown in the base and rover examples in *Transmitting and Receiving Corrections* on page 60.

This requires using the **INTERFACEMODE** command to dedicate one direction of a serial port to one message type only. When the **INTERFACEMODE** command is used to change the mode from the NOVATEL default, the NovAtel format messages can no longer be used.

To mix NovAtel format messages and RTCM V3 messages on the same port, leave the interface mode set to NOVATEL and log out variants of the standard correction messages with a NovAtel header. ASCII or binary variants can be requested by appending an A or B to the standard message name. For example, on the base station:

```
interfacemode com2 novatel novatel
fix position 51.11358042 -114.04358013 1059.4105
log com2 rtcml004b ontime 2
```



1. Interface mode must be set to NOVATEL for the receiver to issue logs with an A or B suffix.
2. Using the receiver in NOVATEL mode consumes more CPU bandwidth than using the native differential messages as shown in *Base Station Configuration* on page 62.
3. To find information on how to send multiple commands and log requests from a computer, search our knowledge database available at novatel.com/support.

At the rover, leave the interface mode default settings (interfacemode com2 novatel novatel). The rover recognizes the default and uses the corrections it receives with a NovAtel header.

The **PSRDIFFSOURCE** command and **RTKSOURCE** command set the station ID values that identify the base stations from which to accept pseudorange or RTK corrections. They are useful commands when the rover station is receiving corrections from multiple base stations.

3.4 ALIGN Heading Master and Remote Configurations

ALIGN technology combines two or more receivers to generate high precision heading and pitch angles between two receivers for real-time navigation.

This section provides instructions for setting up a master station with an ALIGN capable rover receiver for applications that require heading output.



This section is intended for systems that do not use SPAN. If SPAN is used on the system, refer to the configuration in SPAN with Dual Antenna available at docs.novatel.com/OEM7.



This section is for applications that require additional rover receivers. Dual antenna receivers, such as the OEM7720, can provide an ALIGN solution without additional receivers or configuration.



A dual frequency capable GNSS antenna is required to use SPAN, RTK, ALIGN or dual frequency GLIDE.

3.4.1 Automatic Set Up for Direct-Wire Connection between Master and Rover via COM2

The **ALIGNAUTOMATION** command must only be sent to the rover.

```
ALIGNAUTOMATION ENABLE
```

or

```
ALIGNAUTOMATION ENABLE COM2 230400 10 ON
```

3.4.2 Manual Set Up via COM2

Master:

```
serialconfig com2 230400 N 8 1 N on
interfacemode com2 novatel novatelx off
movingbasestation enable
log com2 novatelxobs ontime 1
log com2 novatelxref ontime 1
log headinga onnew
log gphdt onchanged
```

Rover:

```
serialconfig com2 230400 N 8 1 N on
interfacemode com2 novatelx novatel off
rtkportmode com2 ALIGN
log com2 headingext2b onnew
log headinga onnew
log gphdt onchanged
hdtoutthreshold 1.0
```

3.5 GLIDE

NovAtel's GLIDE is a positioning algorithm for single-frequency GPS and GPS/GLONASS applications. GLIDE produces a smooth position output tuned for applications where time relative accuracy (pass-to-pass)

is more important than absolute accuracy. Because of this, it is well suited for agricultural applications.

Multipath signals tend to induce time varying biases and increase the measurement noise on the L1/L2 pseudorange measurements. Carrier phase measurements are much less susceptible to the effects of multipath. The GLIDE algorithm fuses the information from the L1 code and the L1 phase measurements into a Position Velocity Time (PVT) solution.

GLIDE includes settings for a dynamic mode, a static mode and an “auto” mode, where the filtering parameters are automatically adjusted as vehicle velocity varies between stationary and dynamic states.

3.5.1 Dual-Frequency GLIDE

NovAtel's dual-frequency GLIDE technology adds to the superior pass-to-pass performance provided by single-frequency GLIDE. Dual-frequency GLIDE is ideal for agricultural and machine guidance applications where relative positioning is critical. Using GLIDE significantly reduces the variation in position errors to less than 1 cm from one epoch to the next. Dual-frequency GLIDE improves the absolute accuracy of the GLIDE position and creates a robust solution resistant to the effects of high ionospheric activity. GLIDE works in all code positioning modes, including single point, DGNSS and SBAS.

Refer to the NovAtel white paper on [GLIDE Technology](#) for more information on GLIDE and [APN-038: Pseudorange/Delta-Phase \(PDP\) and GLIDE Filters](#) along with other information available from novatel.com/support/support-materials/application-notes.

3.5.2 PDP and GLIDE Configurations

Pseudorange/Delta-Phase (PDP) and GLIDE position filters can be used for single-frequency single point, WAAS or DGNSS positioning. Refer to the **PDPFILTER** command and **PDPMODE** command in the [OEM7 Commands and Logs Reference Manual](#).

To reset the PDP or GLIDE filter:

```
pdpfilter reset
```

To enable the PDP filter:

```
pdpfilter enable
```

Ensure the **PDPFILTER** command is used before the **PDPMODE** command. Set the PDP type and kinematic type according to the application. For most kinematic applications:

```
pdpmode relative dynamic or pdpmode relative auto
```

The rest of the setup is position type and log dependent according to the application. See the **PSRDIFFSOURCE**, **INTERFACEMODE**, **SERIALCONFIG** and other configuration commands which are outlined in the [OEM7 Commands and Logs Reference Manual](#). Also refer to the NovAtel application note [APN-038: Pseudorange/Delta-Phase \(PDP\) and GLIDE Filters](#) available from our web site at novatel.com/support/support-materials/application-notes.

3.6 STEADYLINE

The STEADYLINE functionality helps mitigate the discontinuities that often occur when the receiver changes GNSS positioning modes. The effect is especially evident when a receiver transitions from an RTK position mode solution to a lower accuracy “fall back” solution, such as DGPS, WAAS+GLIDE or even autonomous GLIDE (see *Figure 23: Positioning Change Without STEADYLINE* on the next page). Smooth transitions are particularly important for agricultural steering applications where sudden jumps are problematic.

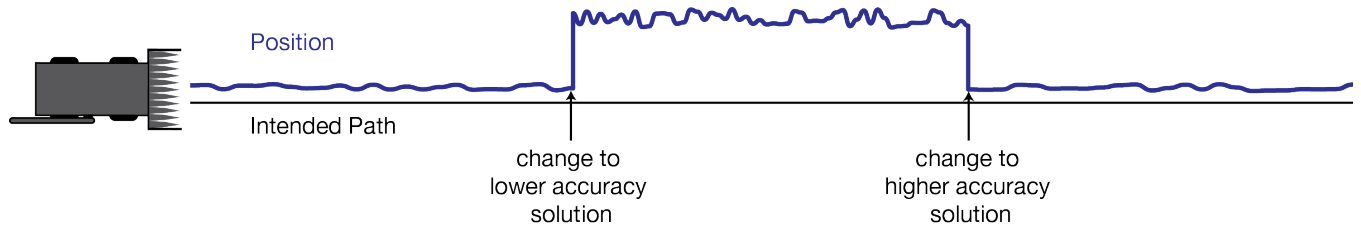
Figure 23: Positioning Change Without STEADYLINE

The STEADYLINE feature internally monitors the position offsets between all the GNSS positioning modes present in the receiver. When the current positioning mode becomes unavailable, the receiver transitions to the next most accurate positioning mode.



Refer to the [OEM7 Commands and Logs Reference Manual](#) for log and command details.

3.6.1 Prefer Accuracy

The positioning mode change depends on the accuracy level of the positioning modes.

When the position mode is changing from a more accurate mode to a less accurate mode (e.g., changing from RTK to GLIDE), the receiver uses the position offset calculated to limit a potential real position jump.

When the position mode is changing from a less accurate mode to a more accurate mode (e.g., GLIDE to RTK), the receiver slowly transitions to the new reference position type over the time period specified by the Transition time parameter.

For example, a receiver is configured to do both RTK and GLIDE. If this receiver has a fixed RTK position and experiences a loss of correction data causing the loss of the RTK solution it will immediately apply the offset between the two position modes and uses the GLIDE position stability to maintain the previous trajectory. Over time the GLIDE (or non-RTK) position will experience some drift. Once the RTK position is achieved again the receiver will start using the RTK positions for position stability and will slowly transition back to the RTK positions at a default rate of 0.005 m/s or the time specified in the **STEADYLINE** command.

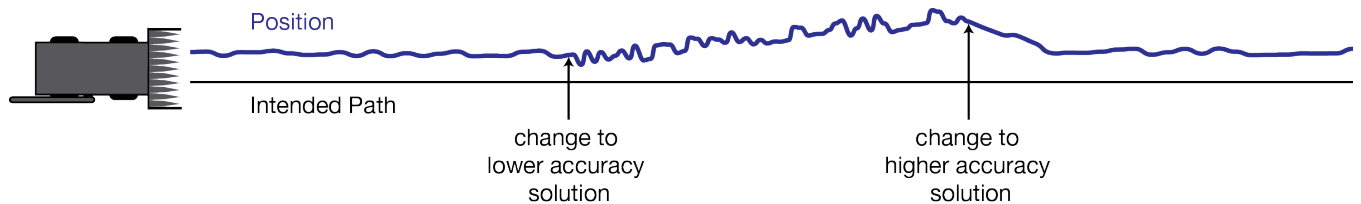
Figure 24: STEADYLINE Prefer Accuracy

3.7 Enabling SBAS Positioning

OEM7 receivers are capable of SBAS positioning. This positioning mode is enabled using the **SBASCONTROL** command:

```
sbascontrol enable auto
```

When the command is entered, the OEM7 receiver automatically tracks the SBAS that is operating in the region (e.g., WAAS or EGNOS) and applies the corrections from the service. On a simulator, leave the test mode parameter off or specify NONE explicitly. For more on SBAS, refer to application note [APN-051 Positioning Modes of Operation](#) (additional Application Notes available at novatel.com/support/support-materials/application-notes) and the known solution [SBAS Positioning](#).

3.8 Enabling PPP

L-Band equipped receivers can achieve sub-metre position accuracy using correction data received from geostationary satellites. To use the L-Band corrections, an L-Band-capable receiver model and antenna are required (refer to our web site novatel.com/products/antennas for information on NovAtel L-Band-capable antennas).

For information on getting started with TerraStar Correction Services, refer to:

- [TerraStar Correction Services Quick Start Guide](#)

For more information on L-Band positioning, refer to:

- NovAtel Application Notes: *APN-087: TerraStar on OEM7* available from novatel.com/support/support-materials/application-notes
- the [OEM7 Commands and Logs Reference Manual](#) for log/command details and/or
- visit novatel.com/support
- visit novatel.com/products/correction-services

3.8.1 TerraStar Subscriptions

A subscription is required to use TerraStar service for land, airborne and near shore applications. Near shore applications are defined as vessels operating within 10 km of shore. For more information about TerraStar services, visit novatel.com/products/gps-gnss-correction-services/terrastar-correction-services. To obtain a subscription, contact your local NovAtel sales representative. The NovAtel product serial number (PSN) is needed to obtain a subscription. To obtain the receiver serial number, enter the following command:

```
log version once
<VERSION USB1 0 74.0 FINESTEERING 2045 336197.080 02028020 3681 15341
< 11
< GPSCARD "FFNRNNCBES1" "BMHR17090005E" "OEM7700-1.00" "OM7CR0504RN0000"
"OM7BR0001RBG000" "2019/Jan/17" "07:30:03"
< OEM7FPGA "" "" "" "OMV070001RN0000" "" "" ""
< WHEELSENSOR "" "" "" "SWS000101RN0000" "" "2019/Jan/17" "07:30:30"
< WIFI "RS9113" "" "" "1.6.8" "" "2019/Jan/17" "07:30:35"
< APPLICATION "" "" "" "EP7AR0504RN0000" "" "2019/Jan/17" "07:30:16"
< DEFAULT_CONFIG "" "" "" "EP7CR0504RN0000" "" "2019/Jan/17" "07:30:26"
< PACKAGE "" "" "" "EP7PR0504RN0000" "" "2019/Jan/17" "07:30:21"
< DB_WWWISO "WWWISO" "0" "" "WMC010201AN0004" "" "2017/Sep/20" "21:00:04"
< ENCLOSURE "" "NMNE17200009B" "" "" "" "" ""
< REGULATORY "US" "" "" "" "" "" ""
< IMUCARD "Epson G320N" "" "" "" "" "" ""
```

In the example above, the receiver serial number is **BMHR17090005E**.

To activate a subscription, the receiver must be powered and tracking an L-Band TerraStar satellite prior to the planned activation time. Use the **ASSIGNLBANDBEAM** command to configure the receiver to track the TerraStar satellite.

```
ASSIGNLBANDBEAM auto
```

To confirm tracking of an L-Band signal, log the L-Band tracking status information by entering the following command:

```
log lbandtrackstata
```

```
#LBANDTRACKSTATA,COM1,0,73.5,FINESTEERING,1769,328196.000,00000000,29fd,
12602;1,"98W",1539902500,1200,974c,00c2,0,-316.186,43.842,4.3840,61.920,
1088,2,2,138176,79,0.0001*3e43cb7d
```

If receiving an L-Band signal from a geostationary satellite, the sixth field following the header (tracking status word) of the LBANDTRACKSTAT log will be 00c2, as shown in the example.



The latest services and coverage can be obtained from novatel.com/products/gps-gnss-correction-services/terrastar-correction-services. For additional information on TerraStar activation, contact NovAtel Customer Service at novatel.com/support or download *APN-061 TerraStar Correction Services* from: novatel.com/support/support-materials/application-notes

To confirm the TerraStar subscription status, send the **TERRASTARSTATUS** log:

```
log terrastarstatus
[COM1]<TERRASTARSTATUS COM1 0 74.0 FINESTEERING 1886 418216.025 00000020 fdc1
13386 ENABLE LOCKED 0 IN_RANGE DISABLED
[COM1]
```

The first field after the log header will be **ENABLE** to indicate the TerraStar subscription is valid. The second field after the log header will be **LOCKED** to indicate the decoder is locked to the data format.

To monitor the PPP convergence, request the **PPPPOS** log:

```
log ppppos ontime 1
[COM1]<PPPPOS COM1 0 76.0 FINESTEERING 1886 418465.000 00000020 ec34 13386 SOL_
COMPUTED PPP_CONVERGING 51.11679035745 -114.03886212905 1064.9475 -16.9000
WGS84 0.7097 0.6867 1.2333 "TSTR" 25.000 0.000 18 17 17 17 00 00 00 33
[COM1]
```

Automatic Multi-Constellation, Multi-Frequency

When using TerraStar service, a multi-constellation, multi-frequency channel configuration gives better accuracy and faster convergence time compared to a dual-constellation, dual-frequency channel configuration. To allow the receiver to make best use of the TerraStar subscription, a multi-constellation, multi-frequency configuration is automatically activated included with TerraStar-X, TerraStar-C PRO or RTK ASSIST PRO subscriptions.

To enable multi-constellation, multi-frequency channel configurations, issue the following commands:

```
TERRASTARCHANCONFIG ENABLE
SAVECONFIG
```

If a TerraStar-X, TerraStar-C PRO or RTK ASSIST PRO subscription is active, a receiver reset is required after issuing these commands.

For more information, or to disable Multi-Constellation, Multi-Frequency channel configuration, see the **TERRASTARAUTOCHANCONFIG** command.



If the TerraStar-X, TerraStar-C PRO or RTK ASSIST PRO subscription becomes inactive, the receiver will revert to the channel configuration enabled by the receiver model.



This feature is available on OEM firmware version 7.06.01 and later.

3.8.2 Veripos Subscriptions



Subscriptions to the Veripos Apex and Apex² marine services must be obtained directly from Veripos. A unit with a marine subscription can not be switched to a land subscription and vice versa.

A subscription is required to use the [Veripos services](#) for offshore marine applications. Contact Veripos sales at veripos.com/support to obtain a Service Access License (SAL) number. To activate the service, contact the Veripos Support at veripos.com/support. Provide the SAL number and the receiver's Veripos Serial Number (VSN). To obtain the receiver-specific VSN, enter the following command:

```
log veriposinfo
```

The log displays the VSN in the first field following the log header and also displays the status of your subscription.

To activate a subscription, the receiver must be powered and tracking an L-Band Veripos satellite prior to the planned activation time. Use the **ASSIGNLBANDBEAM** command to configure the receiver to track the Veripos satellite.

```
assignlbandbeam auto
```



The latest services and coverage can be obtained from www.veripos.com. For additional information on Veripos activation, contact NovAtel Customer Service at novatel.com/support.

3.9 RTK ASSIST

RTK ASSIST is a feature that enables centimetre-level accuracies to be maintained through extended RTK correction outages. With RTK ASSIST, RTK-dependent operations can continue through RTK correction outages as long as 20 minutes.

RTK ASSIST uses correction data provided by TerraStar. To obtain these corrections, an L-Band capable receiver is required and L-Band tracking must be enabled using the **ASSIGNLBANDBEAM** command.

RTK ASSIST also requires a subscription to the RTK ASSIST service. To obtain a subscription, contact your local NovAtel sales representative or visit novatel.com/products/gps-gnss-correction-services/terrastar-correction-services. The NovAtel Product Serial Number (PSN) is needed to obtain a subscription. The PSN is available from the **VERSION** log.

RTK ASSIST is available as soon as the rover receiver has at least one valid RTK solution and has received the RTK ASSIST correction data. If an RTK correction outage occurs, then RTK ASSIST will maintain RTK mode until the subscription-permitted RTK ASSIST duration is exceeded. A shorter, user-defined RTK ASSIST time out can also be set using the **RTKASSISTTIMEOUT** command. Normal RTK operation will seamlessly resume if RTK corrections are restored at any point while RTK ASSIST is operating.

RTK ASSIST will report the RTK solution type that was present before RTK corrections were lost, unless the estimated solution standard deviation exceeds the threshold set by the **RTKINTEGCRITERIA** command. If this occurs, then integer RTK solutions will be downgraded to their float RTK equivalent.

RTK ASSIST is enabled by default, but can be disabled using the **RTKASSIST** command. To monitor the status of RTK ASSIST, view the **RTKASSISTSTATUS** log.

Refer to the [OEM7 Commands and Logs Reference Manual](#) for log and command details.



RTK ASSIST typically provides 4 cm accuracy. However, if the RTK outage occurs during the first 30 minutes of receiver operation, the position accuracy provided by RTK ASSIST may be lower.



Additional information about enabling and using RTK ASSIST is available in [APN-073: RTK ASSIST & RTK ASSIST PRO](#) (available from our website: novatel.com/support/support-materials/application-notes).

3.10 Transferring Time Between Receivers

The **ADJUST1PPS** command is used as part of the procedure to transfer time between receivers. The number of Pulses Per Second (PPS) is always set to 1 with this command. It is typically used when the receiver is not adjusting its own clock and is using an external reference frequency.

The **TIMESYNC** log is also used to synchronize time between receivers. It contains a time status field that may show COARSE or FINE, among others. For a complete list of the time status values and definitions, refer to GPS Reference Time Status in the [OEM7 Commands and Logs Reference Manual](#).

Procedures to Transfer Time on the next page provides details on the time transfer procedure. Terms used in the procedure are defined in *Time Definitions* below. Refer also to the **ADJUST1PPS** command and the **TIMESYNC** log in the [OEM7 Commands and Logs Reference Manual](#).

3.10.1 GPS to Receiver Time Synchronization

Receiver time synchronization with GPS time does not occur until the receiver locks onto the first satellite. The GPS L1 signal has two main streams of data modulated on the carrier. These data streams are the C/A code (1.023 MHz rate) and the P(Y) code (10.23 MHz rate). Additionally, a navigation message (at a 50 Hz rate) contains GPS satellite data including the ephemeris, clock corrections and constellation status. This navigation message is encoded on both the C/A and P(Y) codes. The navigation message is transmitted via individual subframes and each subframe is 300 bits in length. With the 50 Hz data bit rate there is a new subframe transmitted every six seconds.

3.10.2 Time Definitions

The following are related definitions:

Coarse Time

Each subframe contains the transmit time of the next subframe in seconds of GPS Time of Week (TOW). After the first subframe is collected and decoded by the receiver, an approximate calculation of the receiver clock offset can be made. The receiver clock offset is the difference between GPS time and internal receiver time. The calculation is based on subframe transmit time and the approximate propagation time from the satellite signal to the receiver. The position of the satellite and receiver clock offset are used to re-initialize the seconds counter on the receiver, resulting in receiver/GPS time synchronization. The accuracy of the receiver time is expected to be within 30 milliseconds (ms) of GPS time. This initial synchronization is referred to as coarse time and is indicated by COARSE in the time status field of the **TIMESYNC** log.

Fine Time

When at least four satellites are acquired to calculate the antenna position, a more accurate estimate of the receiver clock offset is calculated. The new receiver clock offset is used to synchronize the receiver clock even closer to GPS time. This is referred to as fine time and appears as FINE or FINESTEERING in the time status field of the **TIMESYNC** log. Fine time accuracy is a function of the GPS constellation status and is influenced by external receiver RF delay. For the Standard Position Service (SPS) the time accuracy is specified as 20 ns (1 sigma) with internal compensation.

Fine Clock

An OEM7 receiver that is tracking satellites and has a FINE or FINESTEERING receiver clock state.

Cold Clock

An OEM7 receiver that needs to have its clock synchronized with the Fine receiver. It may have any clock state (except FINE or FINESTEERING) that includes UNKNOWN.

Warm Clock

An OEM7 receiver that has its clock adjusted to greater than 500 ms. Refer to the **TIME** log to view the clock offset.



The [OEM7 Commands and Logs Reference Manual](#) contains details of the logs mentioned above.

3.10.3 Procedures to Transfer Time

These procedures are used to transfer time between a fine clock and a cold or warm clock GPS receiver.



When connecting two receivers to transfer time, disable responses on the COM port used to connect the receivers by issuing the following command on both receivers:

```
interfacemode comX novatel novatel off
```

Where comX is the port used on the receiver.

Transfer COARSE Time (<10 ms) from a Fine Clock to a Cold Clock GPS Receiver

1. Connect a COM, USB or Ethernet port from the fine clock receiver to the cold clock receiver (for example, COM2 on the fine clock receiver to COM3 on the cold clock receiver) as shown in *Figure 25: Transfer COARSE Time from Fine Clock to Cold Clock Receiver* on the next page. Configure both ports to the same baud rate and handshaking configurations.
2. Issue the following command to the fine clock receiver:

```
log com2 timesyncb ontime 1
```

3. Issue the following command to the cold clock receiver:

```
adjust1pps time
```

When the cold clock receiver receives the **TIMESYNC** log, it sets its clock with a 100 ms transfer delay allowance.

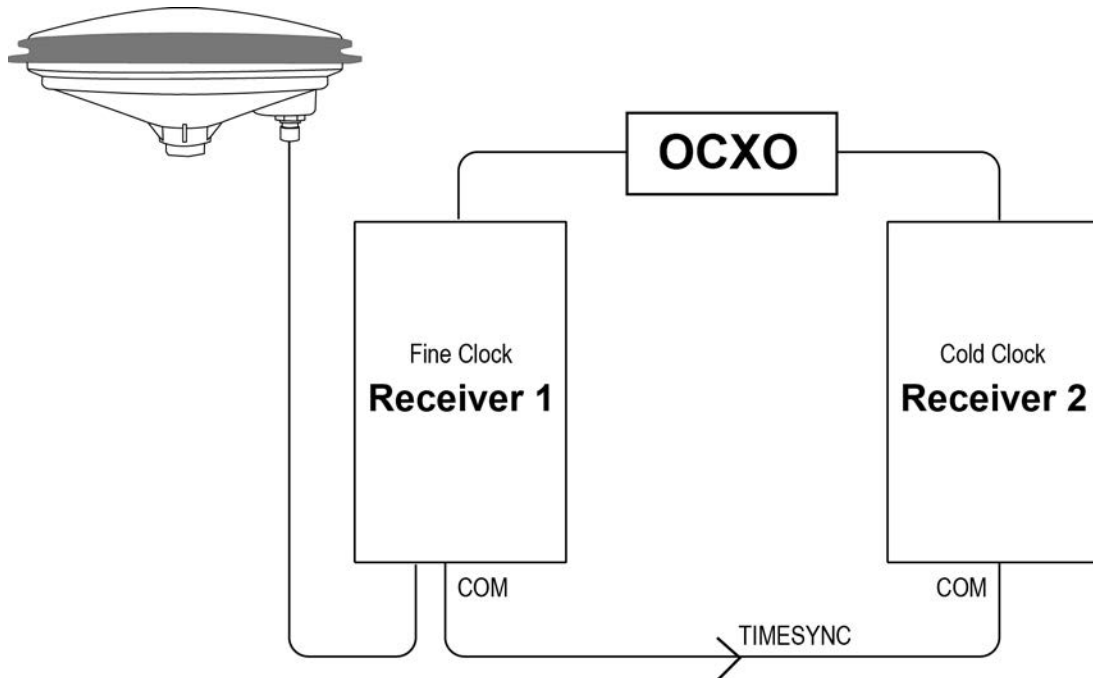
Figure 25: Transfer COARSE Time from Fine Clock to Cold Clock Receiver**Transfer FINE Time (<50 ns) from a Fine Clock to a Cold Clock GPS Receiver**

1. Connect a COM, USB or Ethernet port from the fine clock receiver to the cold clock receiver (for example, COM2 on the fine clock receiver to COM3 on the cold clock receiver), as shown in *Figure 26: Transfer FINE Time from Fine Clock to Cold Clock Receiver* on the next page. Configure both ports to the same baud rate and handshaking configurations.
2. Issue the following command to the fine clock receiver:

```
log com2 timesyncb ontime 1
```

3. Connect the 1PPS signal of the fine clock receiver to the Mark 1 input (Event1) of the cold clock receiver.
4. Issue the following command to the cold clock receiver:

```
adjust1pps markwithtime
```

When the cold clock receiver receives the 1PPS event from the fine clock receiver, it checks to see if a valid **TIMESYNC** log has arrived within 200 ms of the last 1PPS event. If so, it sets the cold clock receiver clock to the time of the fine clock receiver. See *Figure 28: 1 PPS Alignment* on page 75.

Figure 26: Transfer FINE Time from Fine Clock to Cold Clock Receiver

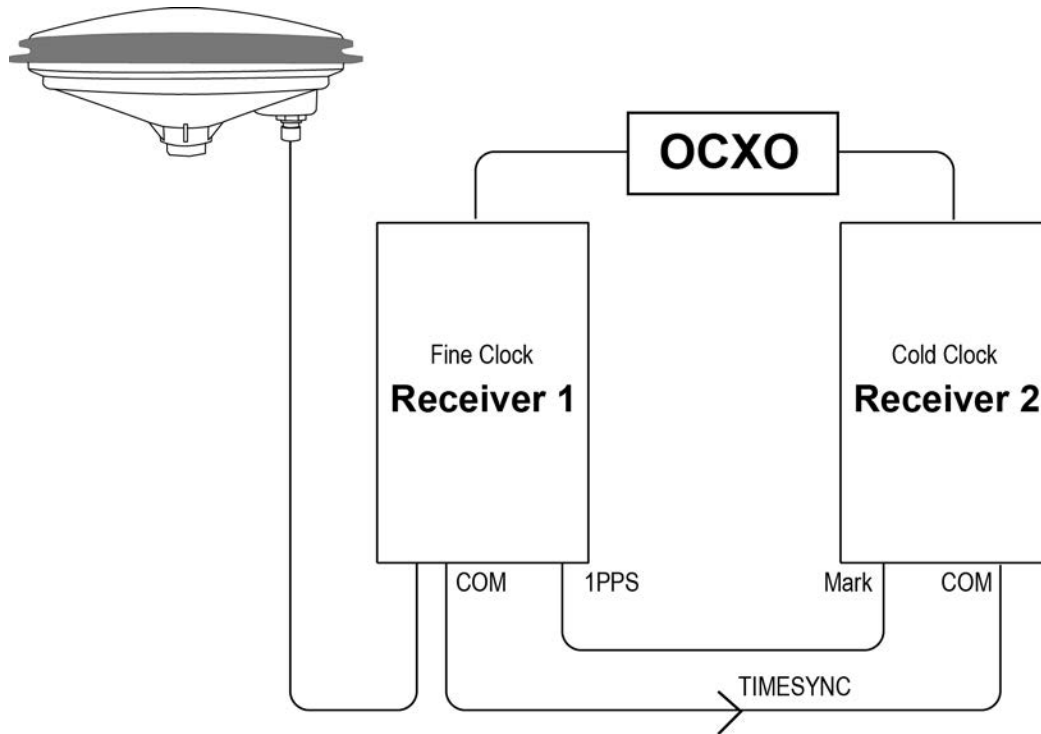

Transfer FINE Time from a Fine Clock to a Warm Clock GPS Receiver

1. Connect the 1 PPS signal of the fine clock receiver to the Mark 1 input (Event1) of the warm clock receiver as shown in *Figure 27: Transfer FINE Time from Fine Clock to Warm Clock Receiver* on the next page.
2. Issue the following command to the warm clock receiver:

```
adjust1pps mark
```

The phase of the warm clock receiver clock is adjusted by the fractional measurement of the fine clock receiver's 1 PPS mark input event. In other words, it synchronizes the warm clock receiver's 1 PPS to the incoming 1 PPS of the fine clock receiver. It does not adjust the one second TOW counter or the receiver's week number. This procedure is used to make small corrections to the warm clock receiver's clock.

Figure 27: Transfer FINE Time from Fine Clock to Warm Clock Receiver

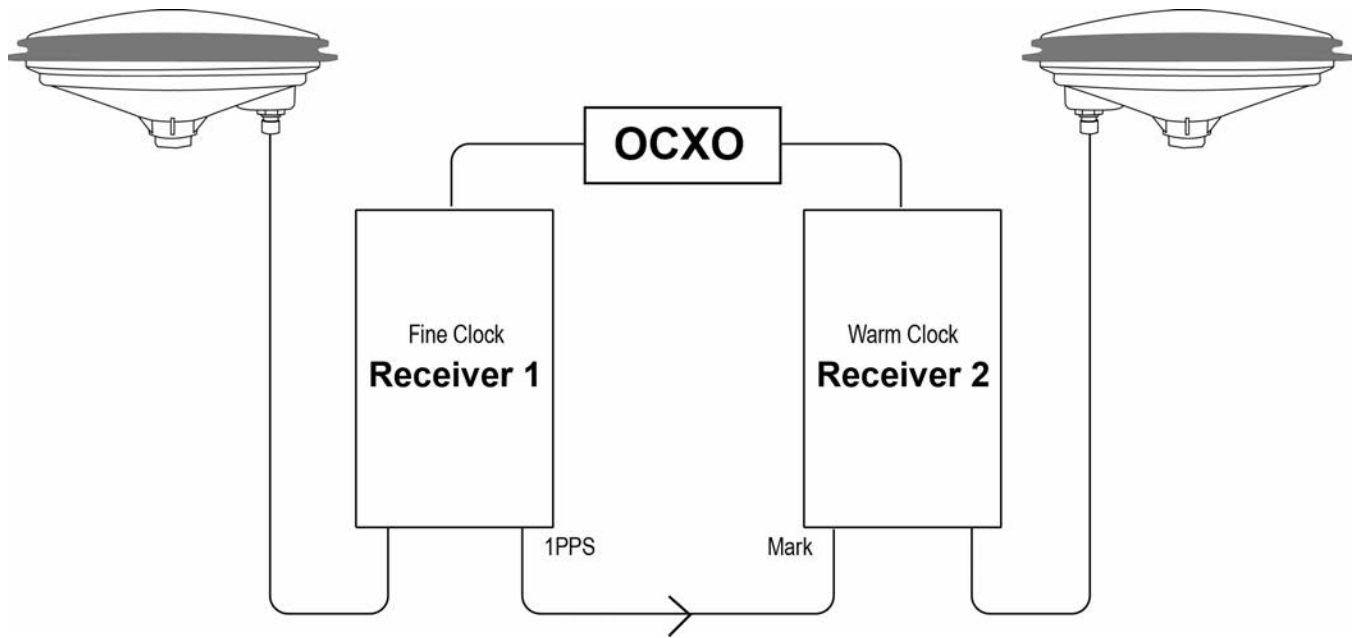

If Receiver 2 is not in coarsetime, the input is ignored.

Figure 28: 1 PPS Alignment

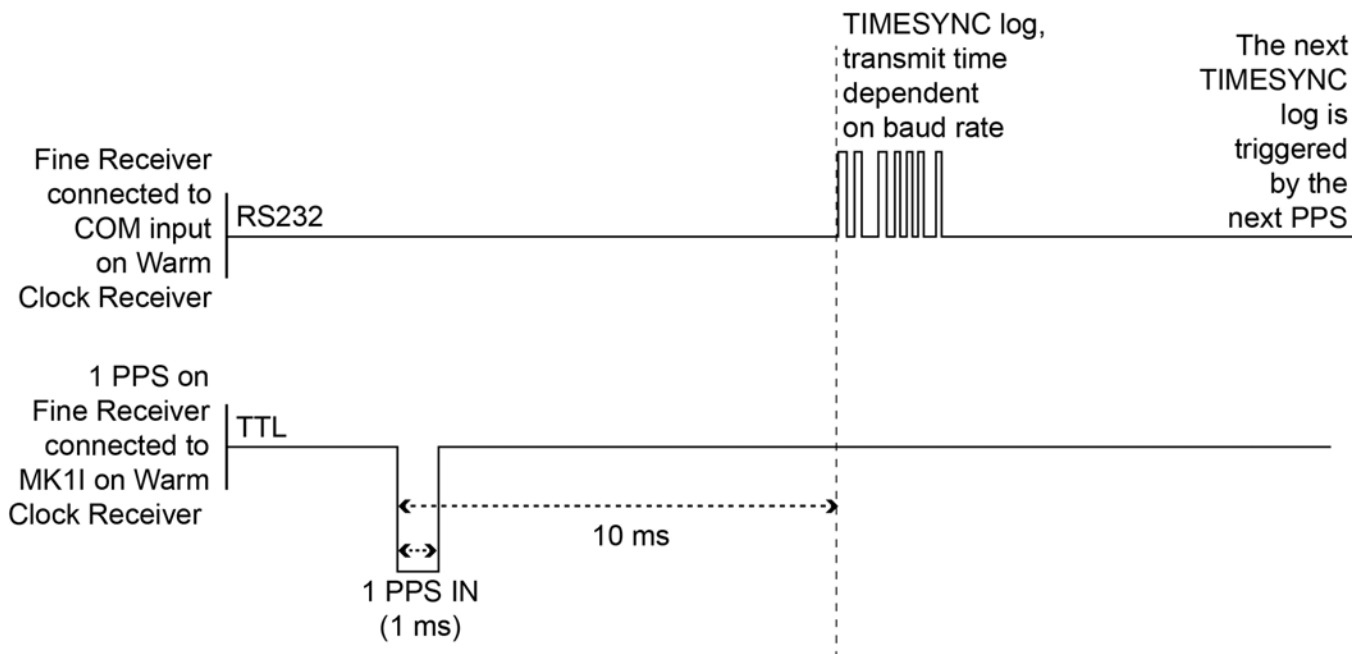



The examples shown in *Figure 25: Transfer COARSE Time from Fine Clock to Cold Clock Receiver* on page 73, *Figure 26: Transfer FINE Time from Fine Clock to Cold Clock Receiver* on page 74 and *Figure 27: Transfer FINE Time from Fine Clock to Warm Clock Receiver* on the previous page are for the transfer of time. If a position is needed, the receiver must be tracking satellites and must have a valid almanac.

3.11 Interference Toolkit

The Interference Toolkit (ITK) feature monitors, quantifies and removes interference sources to prevent interference from impacting receiver performance.

Using the Interference Toolkit, you can monitor the Radio Frequency (RF) spectrum in a range of frequencies around the GNSS signals that are being received by the OEM7 receiver. If an interference signal is detected, information about the interference is output in the **ITDETECTSTATUS** log. More information about the interference signal can be determined by plotting the information obtained.

Signals available are model dependent. A variety of mitigation techniques are available. Contact novatel.com/contactus/sales-offices to activate full mitigation features.

3.11.1 Monitoring GNSS Signals

By default, interference detection is enabled. Detection can be disabled/enabled as needed. See *Disable/Enable Detection* on page 78 for instructions. Detected interference can be viewed and different tracking modes with possible additional filters can be applied to mitigate the interference using NovAtel Application Suite. Detected interference details can also be logged and analyzed using the command line interface.

There are two types of interference detection available, Spectral Analysis Detection and Statistical Analysis Detection.



NovAtel recommends using the default settings for Interference Toolkit whenever possible.

Spectral Analysis Detection

Spectral Analysis Detection is focused on in-band, near-band, and strong out-band interference detection.

OEM7 uses receiver gain calibration data that is stored in receiver memory at receiver start-up. The calibration data is used to estimate the antenna gain before the receiver, as well as generate interference free spectrum reference for spectral analysis detection. The receiver assumes that the receiver is in an interference free environment during start-up and the antenna is connected to the receiver and powered up.



When using the Interference Toolkit, the receiver must be reset when the GNSS antenna is connected or disconnected.



If a known interference source is present at the receiver start up, it's strongly recommended that users enter the calibrated receiver input gain using the **RFINPUTGAIN** command.

Measuring the RF Input Gain



This section is intended for advanced users.

The **RFINPUTGAIN** command allows users to enter a more accurate receiver input condition, which is considered as a calibrated receiver input condition, and is used for interference detection. This command supports different values for L1, L2, L5, and L-Band and is recommended when there is a known strong interference present at receiver start up.

To calibrate the receiver input level, use a standard spectrum analyzer to measure the receiver input noise density in dBm/Hz. Make sure the pre-amplifier is turned on in Spectrum Analyzer under “Amplitude”. Place the Marker around L1, L2, L5, or L-Band frequency region and select “noise density” under “Marker Function”.

$RFINPUTGAIN = \text{Receiver Input Noise Density (dBm/Hz)} - \text{Typical Thermal Noise KT of } -174\text{dBm/Hz}$,
where:

$$K = 1.38E-23\text{w-sec/K}$$

$$T = 290 \text{ k.}$$

For example, if the receiver input noise density measured at L1 is -144dBm/Hz,

$$RFINPUTGAIN = -144 - (-174) = 30\text{dB for L1 path.}$$

Alternatively, if a spectrum analyzer is not available, the **RFINPUTGAIN** can be obtained using the cascaded RF gain before the receiver plus LNA noise figure (NF), including LNA gain in antenna, in-line amplifier gain (if applicable), RF cable or distribution loss prior to receiver input connector. A typical GNSS active antenna with reasonable quality has a noise figure of ~2dB.

$$RFINPUTGAIN = \text{Cascaded Gain before receiver} + \text{LNA NF}$$

For example, if system cumulative gain measured before receiver is ~25dB, and LNA NF is around 2dB, the **RFINPUTGAIN** = 27dB.

```
RFINPUTGAIN L1 27
```

```
RFINPUTGAIN L2 27
```

```
RFINPUTGAIN L5 27
```

```
RFINPUTGAIN LBand 27
```

Statistical Analysis Detection

Statistical Analysis Detection is focused on out of band interference detection. It is supplementary to the Spectrum Analysis Detection and is useful when interference is outside the analog passband of the receiver and creating distortion that may not be visible to Spectrum Analysis Detection until the interference is very strong.

The Statistical Analysis Detection is designed as a sensitive detection tool. Out of band mitigation does not impose much penalty when enabled and it brings awareness to unintentional interferences next to GNSS operations.



Spectral Analysis Detection takes precedent over Statistical Analysis Detection. If the same interference is detected by both detectors, only Spectral Analysis Detection is used to report the interference status.

3.11.2 Disable/Enable Detection

The interference detection feature can be enabled/disabled from the command line using the **ITDETECTCONFIG** command.

To disable interference detection, enter:

```
ITDETECTCONFIG none
```

To enable interference on all RF paths, enter :

```
ITDETECTCONFIG all
```

Interference detection can also be enabled on individual RF paths. See the **ITDETECTCONFIG** command for details.

The sensitivity level for setting the *Jammer Detected* bit in the *Receiver Status* word in the log headers can be configured using the **ITWARNINGCONFIG** command. By default it is set to the least sensitive setting, meaning that interference needs to be severe for this bit to be set.

3.11.3 Monitoring Signals Using a Command Line

The **ITDETECTSTATUS** log lists all detected interference signals. For interference detected by spectral analysis, the log also provides the center frequency and bandwidth of the interference signal. With this information, a filter can be configured to mitigate the interference.



Due to the high volume of data, a higher bandwidth medium, such as USB or Ethernet, is recommended when monitoring signals using the Interference Toolkit.

Example:

```
LOG ITDETECTSTATUS onchanged
#ITDETECTSTATUSA,USB2,0,74.0,FINESTEERING,1982,430605.267,0200c000,7fdb,32768;
3,
L1,STATISTICANALYSIS,-0.718,29.167,0.126,12.797,00000000,00000000,00000000,
L2,SPECTRUMANALYSIS,1249.961,71.191,-56.769,-132.907,00000000,00000000,
00000000,
L2,SPECTRUMANALYSIS,1289.512,1.978,-75.967,-138.493,00000000,00000000,00000000
*5e83b175
```

In the above example, there are three interference signals detected:

- Out of band interference near L1 (STATISTICANALYSIS)
- Interference in the L2 band at 1249.961 MHz
- Interference in the L2 band at 1289.512 MHz

To view details about the signals that are being received by the OEM7 receiver and determine if there is an interference signal within the GNSS signals, use the **ITSPECTRALANALYSIS** command to enable and configure the spectral analysis. The spectrum can then be viewed by plotting the PSD samples in the **ITPSDFINAL** log. NovAtel Application Suite can also be used to view the spectrum. See *Monitoring Signals Using NovAtel Application Suite* on the next page.

Example:

```
ITSPECTRALANALYSIS PREDECIMATION GPSL1 200 2K 1 1
LOG ITPSDFINAL onnew
```

When logged, incoming signal information is collected at the rate specified in the **ITSPECTRALANALYSIS** command.



Pre-decimation – Raw analog-to-digital converter signals.
Post-decimation – Analog-to-digital converted signal for the specific signal encoder path. This gives a narrower view of the incoming signal.

3.11.4 Monitoring Signals Using NovAtel Application Suite



Due to the high volume of data, a higher bandwidth medium, such as USB or Ethernet, is recommended when monitoring signals using the Interference Toolkit.

Start NovAtel Application Suite and open a *Setup & Monitor* connection to the OEM7 receiver.

Click **Tools** and select **Interference Toolkit**. The *Interference Toolkit* window opens. The following example shows a typical signal.

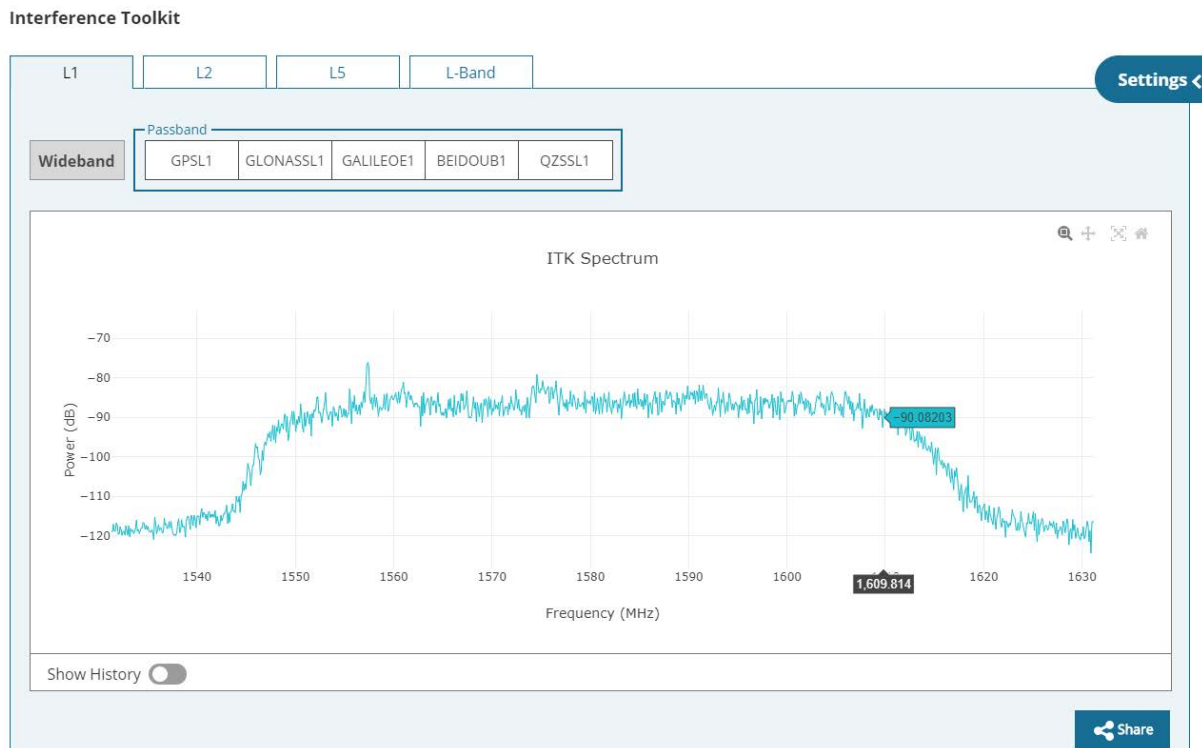

Placing the cursor over any place in the signal band will display additional information regarding that location in the signal band.

For information about using the Interference Toolkit in NovAtel Application Suite, refer to docs.novatel.com/Tools/Content/Setup_Monitor/InterferenceToolKit.htm.

3.11.5 Remove Interference Signals

If an interference signal is present, the Interference Toolkit can reduce or eliminate the impact on GNSS tracking using the programmable High Dynamic Range (HDR), Bandpass or Notch filters.

Contact novatel.com/contactus/sales-offices to obtain mitigation functionality.

High Dynamic Range Mode

The High Dynamic Range (HDR) mode enables special signal processing to remove distortions from the spectrum, providing a cleaner signal. This optimizes the Automatic Gain Control (AGC) to prevent interfering signals from drowning out the GNSS signals. HDR mode works well against wide band and out-of-band interferers. HDR mode can be combined with bandpass and notch filters, but does draw more power.

To configure HDR mode, use the **ITFRONTENDMODE** command. HDR mode can also be enabled using NovAtel Application Suite.

Notch Filter

The Interference Toolkit notch filter reduces the signal power in a narrow frequency band. This type of filter is useful for reducing the signal power of a single, narrow band interference signal. Note that the narrowest possible filter should be used to maintain the maximum amount of overall signal power.

To configure a notch filter, use the **ITPROGFILTCONFIG** command. A notch filter can also be configured using NovAtel Application Suite.

Bandpass Filter

The Interference Toolkit bandpass filter reduces the signal power of all incoming signals at the upper and lower end of the GNSS signal band starting at the requested cut-off frequency. This type of filter is good for reducing single or multiple interference signals at the edges of the signal band.

When a bandpass filter is applied to this signal, the upper and lower ends of the signal band are filtered out to reduce the signal power of the interference signal.

To configure a bandpass filter, use the **ITPROGFILTCONFIG** command or the **ITBANDPASSCONFIG** command. A bandpass filter can also be configured using NovAtel Application Suite.

3.11.6 Interference Toolkit Commands and Logs

The following are the commands and logs used by the Interference Toolkit to monitor, apply filters and mitigate interference. Commands and logs with the ✓ are available by default. Contact novatel.com/contactus/sales-offices to activate full mitigation features.

Commands		
ITBANDPASSCONFIG		Configures a bandpass filter on the receiver.
ITDETECTCONFIG	✓	Enables or disables automatic interference detection on the receiver.
ITFRONTENDMODE		Configures the front end mode for each RF path to use the default tracking mode or change to High Dynamic Range (HDR) mode.
ITPROGFILTCONFIG		Configures filtering on the receiver to be either a notch filter or a bandpass filter.
ITSPECTRALANALYSIS	✓	Configures and enables spectral analysis on the receiver.
ITWARNINGCONFIG	✓	Configures the interference detection threshold on the receiver.

Logs		
ITBANDPASSBANK		Provides the allowable bandpass filter configurations.
ITDETECTSTATUS	√	Lists all of the interference detected on the paths on which automatic interference detection has been enabled.
ITFILTTABLE		Summarizes the filter configuration for each frequency and indicates which bandpass or notch filters are enabled and configured.
ITPROGFILTBANK		Provides the allowable programmable filter configurations.
ITPSDFINAL	√	Provides the power spectral density information of the specified signal path.

3.12 Logging and Retrieving Data Overview

Logs can be directed to any of the receiver communication ports and can be automatically generated at regular intervals or when new or changed data becomes available.

Data can be collected using NovAtel Application Suite or Setup & Monitor (Web). Refer to docs.novatel.com/Tools for comprehensive logging instructions.

3.12.1 Pass-Through Logging

The pass-through logging feature enables the GNSS receiver to redirect any ASCII or binary data that is input at a specified COM port or USB port, to any specified receiver COM or USB port. This capability, in conjunction with the SEND command, allows the receiver to perform bidirectional communications with other devices such as a modem, terminal or another receiver.

There are several pass-through logs available on OEM7 receivers for logging through serial ports. Refer to the PASSCOM logs in the [OEM7 Commands and Logs Reference Manual](#) for details.

3.12.2 Saving Logs to a File

To save log data, log requests are sent to the FILE port (for example, LOG FILE BESTPOS ONTIME 1). Before the logs sent to the FILE port can be saved in a file, the file must be created (opened) on the file system using the FILECONFIG OPEN command. The log file will open when the active file media is ready and has sufficient space.

File Naming

When a file is opened, the file name is generated based on the following format:

```
<PSN>_<INDEX>.LOG
```

where:

- <PSN> is the product serial number of the enclosure
- <INDEX> is a number from 1 to 511.

The lowest number that produces an unused file name is selected. If there is no such number available, the **FILESTATUS** log will report an error.

The number is not zero-padded (i.e. the sequence is as follows: 1,2, ... ,9,10,11,12, ... ,99,100, ... , 510,511).

When a file is closed (FILECONFIG CLOSED) and the receiver has a valid time, the file is renamed based on the following format:

```
<PSN>_<UTC Date>_<UTC Time>.LOG
```

where:

- <PSN> is the product serial number of the enclosure
- <UTC_Date> is the UTC date in the format YYYY-MM-DD
- <UTC_Time> is the UTC time in the format HH-MM-SS

Example file name: NOV12001200A_2017-01-10_12-14-34.LOG

When a file is closed, but the receiver does not have a valid time, the file is left with its automatically generated name.



- The file is created before the **FILECONFIG** command returns a response.
- Only logs that are published after the log file is open are recorded.
- Only one log file can be open at a time.
- Logs requested to the FILE port are still produced even if the log file is closed, however the logs are not recorded. (This is similar to requesting logs to COM4 when there is not connection to COM4.) If a new log file is opened, recording of the previously requested logs continues with the new file.

File Rotation

When collecting a large amount of log data over an extended time period, the maximum size and duration for a log file can be configured using the **FILEROTATECONFIG** command.

If the file duration is set, the log file is closed after the specified duration and a new log file is created. If the file size is set, the log file is closed after the file reaches the specified size and a new log file is created. New log files are created and closed until the file system runs out of free space or logging is stopped. If the **OVERWRITE** mode has been set, the oldest file will be deleted in order to make room for the new file so data logging can continue.

There is no data loss during the file rotation process and individual logs within the file are not spread between log files.

For more information about configuring file rotation, refer to the **FILEROTATECONFIG** command in the [OEM7 Commands and Logs Reference Manual](#).



The maximum size of a log file is 4 GB. Once this size is reached, the log file will close. Another log file will be created to continue logging.

3.12.3 Logging Using NovAtel Application Suite or Setup & Monitor (Web)

The NovAtel user interface tools, *NovAtel Application Suite* and *Setup & Monitor (Web)*, provide a graphic user interface to configure the logs output from an OEM7 receiver.

For information about configuring logging using NovAtel Application Suite, refer to docs.novatel.com/Tools/Content/Setup_Monitor/ConfigurationLogging.htm.

For information about configuring logging using Setup & Monitor (Web), refer to docs.novatel.com/Tools/Content/WebUI_ConfigurationWindows/LoggingConfig.htm.



For information about using NovAtel Application Suite or Setup & Monitor (Web), refer to docs.novatel.com/Tools.

3.13 Additional Features and Information

The following sections contain information on additional features of the OEM7 receivers.

- *Strobes* below
- *Status Indicator* below
- *External Oscillator* below

3.13.1 Strobes

OEM7 receivers have inputs and outputs, referred to as strobes, that provide status and synchronization signals. Not all strobes are provided on all receivers. For detailed information about OEM7 receiver strobes, see:

- *OEM719 Strobe Specifications* on page 148
- *OEM729 Strobe Specifications* on page 165
- *OEM7600 Strobe Specifications* on page 183
- *OEM7700 Strobe Specifications* on page 205
- *OEM7720 Strobe Specifications* on page 228

3.13.2 Status Indicator

OEM7 receiver cards have an LED indicator to provide receiver status.

OEM719	Refer to <i>Figure 13: OEM719 Connector and Indicator Locations</i> on page 41
OEM729	Refer to <i>Figure 14: OEM729 Connector and Indicator Locations</i> on page 42
OEM7600	Refer to <i>Figure 15: OEM7600 Connector and Indicator Locations</i> on page 43
OEM7700	Refer to <i>Figure 16: OEM7700 Connector and Indicator Locations</i> on page 44
OEM7720	Refer to <i>Figure 17: OEM7720 Connector and Indicator Locations</i> on page 45

The LED blinks green at approximately once per second to indicate normal operation. If the indicator is red, the receiver is not working properly. The indicator's operation is described in *Built-In Status Tests* on page 85.

3.13.3 External Oscillator



This feature is supported only on the OEM729.

For applications requiring greater precision than what is possible using the on-board Voltage Controlled, Temperature Compensated Crystal Oscillator (VCTCXO), the OEM729 can be connected to an external, high stability oscillator, at 5 MHz or 10 MHz.

Connect a cable from the external oscillator to the receiver's external oscillator input connector. For the OEM729, a MMCX female connector (J1901) is used as shown in *Figure 14: OEM729 Connector and*

Indicator Locations on page 42. The receiver does not have to be powered down during this operation. However, if handling a card directly, observe anti-static practices. The OEM729 input impedance is 50 ohms. When the external oscillator is installed, use the **EXTERNALCLOCK** command (refer to [OEM7 Commands and Logs Reference Manual](#) for details) to set the clock type (e.g.: cesium, rubidium or ovenized crystal) and frequency.

Chapter 4 Built-In Status Tests

The Built-In Status Test monitors system performance and status to ensure the receiver is operating within specifications. The test detects an exceptional condition and informs the user through one or more indicators. The receiver status system is used to configure and monitor the indicators:

1. Receiver status word (included in the header of every message)
2. ERROR strobe signal
3. RXSTATUSEVENT log
4. RXSTATUS log
5. Status LED

In normal operation, the error strobe is driven low and the status LED on the receiver flashes green once every second. When an unusual and non-fatal event occurs (for example, there is no valid position solution), a bit is set in the receiver status word. Receiver operation continues normally, the error strobe remains off and the LED continues to flash green. When the event ends (for example, when there is a valid position solution), the bit in the receiver status word is cleared.

When a fatal event occurs (for example, a receiver hardware failure), a bit is set in the receiver error word, part of the **RXSTATUS** log, to indicate the cause of the problem. Bit 0 is set in the receiver status word to show that an error occurred, the error strobe is driven high and the status LED flashes red and yellow showing an error code. An **RXSTATUSEVENT** log is generated on all ports to show the cause of the error. Receiver tracking is disabled but command and log processing continues to allow error diagnosis. Even if the source of the error is corrected, the receiver must be reset to resume normal operation.

These two scenarios describe factory default behavior. These behaviors can be customized to better suit an individual application. **RXSTATUSEVENT** logs can be disabled completely with the **UNLOG** command. **RXSTATUSEVENT** logs can be generated when a receiver status bit is set or cleared with the **STATUSCONFIG SET** and **STATUSCONFIG CLEAR** commands. Bits in the receiver status word can also be promoted to act like error bits with the **STATUSCONFIG PRIORITY** command.

4.1 Receiver Status Word

The receiver status word indicates the current status of the receiver. This word is found in the header of all logs and in the **RXSTATUS** log. In addition, the receiver status word is configurable.

The importance of the status bits can be determined with priority masks. For receiver status, setting a bit in the priority mask causes the condition to trigger an error. The error causes the receiver to idle all channels, turn off the antenna and disable the RF hardware, just like it would if a bit in the receiver error word is set. Setting a bit in an Auxiliary Status priority mask causes the condition to set the bit in the receiver status that corresponds to the auxiliary status.

Use the **STATUSCONFIG** command to configure the various status mask fields in the **RXSTATUS** log. Use the masks to specify whether various status fields generate errors or event messages when set or cleared.

Refer to the **RXSTATUS** log, **RXSTATUSEVENT** log and **STATUSCONFIG** command in the [OEM7 Commands and Logs Reference Manual](#) for more detailed descriptions of these messages.

4.2 Error Strobe Signal

The error strobe signal is one of the I/O strobes. The strobe signal is driven low when the receiver is operating normally. When the receiver is in the error state and tracking is disabled, the error strobe is driven high. This can be caused by a fatal error or by an unusual receiver status indication that the user has promoted to be treated like a fatal error. Once on, the error status remains high until the cause of the error is corrected and the

receiver is reset. For more information about the error strobe signal, see *OEM729 Strobe Specifications* on page 165, *OEM7600 Strobe Specifications* on page 183, *OEM7700 Strobe Specifications* on page 205 or *OEM7720 Strobe Specifications* on page 228.



An Error Strobe signal is not available on the OEM719.

When the receiver is in an error state, information about the error is provided in the **RXSTATUS** log. See the [OEM7 Commands and Logs Reference Manual](#) for information about this log

4.3 RXSTATUSEVENT Log

The **RXSTATUSEVENT** log is used to output event messages, as indicated in the **RXSTATUS** log.

On start up, the OEM7 receiver is set to log **RXSTATUSEVENTA ONNEW** on all ports. You can remove this message using the **UNLOG** command.

Refer to the **RXSTATUSEVENT** log in the [OEM7 Commands and Logs Reference Manual](#) for log and command details for a more detailed description of this log.

4.4 RXSTATUS Log

The Receiver Status log (RXSTATUS) provides system status and configuration information in a series of hexadecimal words.

4.4.1 Status Word

The status word is the third field after the header, as shown in the example in *Figure 29: Location of Receiver Status Word* below.

Figure 29: Location of Receiver Status Word

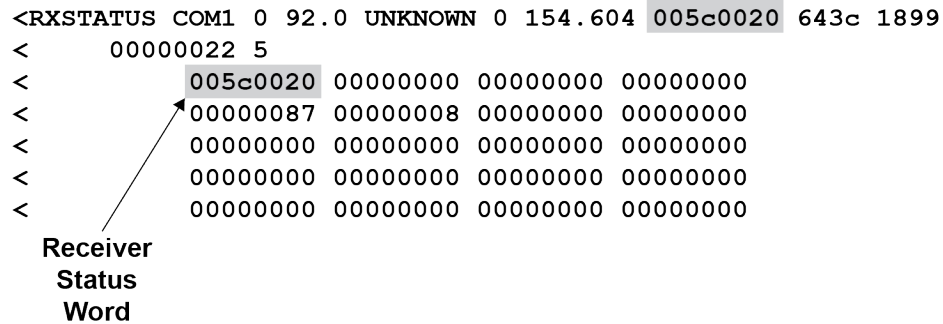

Each bit in the status word indicates the status of a specific receiver condition or function. If the status word is 00000000, the receiver is operating normally. The numbering of the bits is shown in *Figure 30: Reading the Bits in the Receiver Status Word* below.

Figure 30: Reading the Bits in the Receiver Status Word

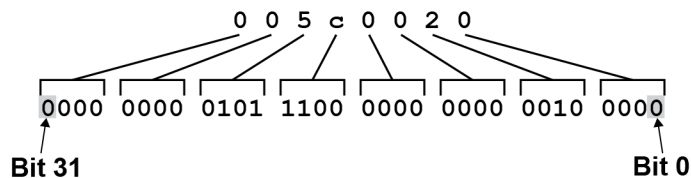

If the receiver status word indicates a problem, see *Examining the RXSTATUS Log* on page 106.

4.4.2 Error Word

The error field contains a 32-bit word. Each bit in the word is used to indicate an error condition. Error conditions may result in damage to the hardware or erroneous data, so the receiver is put into an error state. If any bit in the error word is set, the receiver sets the error strobe line, flashes the error code on the status LED, broadcasts the **RXSTATUSEVENT** log on all ports (unless the user has unlogged it), idles all channels, turns the antenna off and disables the RF hardware. To override the error state, reset the receiver.

The receiver can be configured to generate event messages triggered by status conditions. Receiver Error words automatically generate event messages. These event messages are output in the **RXSTATUSEVENT** log (see also *Set and Clear Mask for all Status Code Arrays* on the next page).

The error word is the first field after the log header in the **RXSTATUS** log, as shown in the example in *Figure 31: Location of Receiver Error Word* below.

Figure 31: Location of Receiver Error Word

```
<RXSTATUS COM1 0 92.0 UNKNOWN 0 154.604 005c0020 643c 1899
< 00000022 5
< 005c0020 00000000 00000000 00000000
< 00000087 00000008 00000000 00000000
< 00000000 00000000 00000000 00000000
< 00000000 00000000 00000000 00000000
< 00000000 00000000 00000000 00000000
```

Receiver
Error
Word

Figure 32: Reading the Bits in the Receiver Error Word below shows an example of a receiver error word.

Figure 32: Reading the Bits in the Receiver Error Word

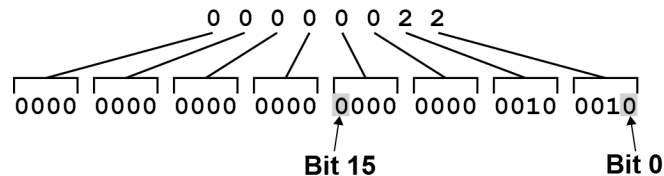

Refer to the **RXSTATUS** log and **RXSTATUSEVENT** log in the [OEM7 Commands and Logs Reference Manual](#) for more detailed log descriptions. If the receiver error word indicates an error, refer to *Examining the RXSTATUS Log* on page 106.

4.4.3 Status Code Arrays

There are currently 5 status code arrays:

- receiver status word
- auxiliary 1 status
- auxiliary 2 status
- auxiliary 3 status
- auxiliary 4 status

Each status code array consists of four 32-bit words (the status word, a priority mask, a set mask and a clear mask). The status word is similar to the error word, with each of the 32 bits indicating a condition. The priority

mask words are used to modify the behavior caused by a change in one of the bits in the associated status words. Each bit, in any mask, operates on the bit in the same position in the status word. For example, setting bit 3 in the priority mask changes the priority of bit 3 in the status word.

Figure 33: Status Code Arrays

```

<RXSTATUS COM1 0 92.0 UNKNOWN 0 154.604 005c0020 643c 1899
<      00000022 5
<      005c0020 00000000 00000000 00000000 ← Receiver Status
<      00000087 00000008 00000000 00000000 ← Auxiliary 1 Status
<      00000000 00000000 00000000 00000000 ← Auxiliary 2 Status
<      00000000 00000000 00000000 00000000 ← Auxiliary 3 Status
<      00000000 00000000 00000000 00000000 ← Auxiliary 4 Status

```

↑
↑
↑
↑

Status Word
Priority Mask
Set Mask
Clear Mask

4.4.4 Receiver Status Code

The receiver status word is included in the header of all logs. It has 32 bits that indicate certain receiver conditions. If any of these conditions occur, a bit in the status word is set. Unlike the error word bits, the receiver continues to operate, unless the priority mask for the bit has been set. The priority mask bit changes the bit in the receiver status word into an error bit. Anything that results from an error bit becoming active also occurs if a receiver status and its associated priority mask bits are set.

4.4.5 Auxiliary Status Codes

The auxiliary status codes are only in the **RXSTATUS** log. The four arrays that represent the auxiliary status codes indicate the receiver state for information purposes only. The events represented by these bits typically do not cause receiver performance degradation. The priority mask for the auxiliary codes does not put the receiver into an error state. Setting a bit in the auxiliary priority mask results in the corresponding bit in the receiver status code to be set if any masked auxiliary bit is set. Bit 31 of the receiver status word indicates the condition of all masked bits in the auxiliary 1 status word. Likewise, bit 30 of the receiver status word corresponds to the auxiliary 2 status word and bit 29 to the auxiliary 3 status word.

Refer also to the **RXSTATUS** log in the [OEM7 Commands and Logs Reference Manual](#) for a more detailed description.

4.4.6 Set and Clear Mask for all Status Code Arrays

The other two mask words in the status code arrays operate on the associated status word in the same way. These mask words are used to configure the bits in the status word that result in a **RXSTATUSEVENT** log broadcast. The set mask is used to turn logging on temporarily while the bit changes from the 0 to 1 state. The clear mask is used to turn logging on temporarily while the bit changes from a 1 to a 0 state. Note the error word does not have any associated mask words. Any bit set in the error word results in a **RXSTATUSEVENT** log broadcast (unless unlogged).

Refer also to the **RXSTATUS** log in the [OEM7 Commands and Logs Reference Manual](#) for a more detailed description.

4.5 Status LED

The diagnostic LED provided on the OEM7 receiver cards blinks green on and off approximately once per second to indicate normal operation.

Error bits and status bits that have been priority masked as errors cause the LED to flash a code in a binary sequence. The binary sequence is a six flash (0.5 second on and 0.25 second off per flash) sequence followed by a one second delay. The sequence repeats indefinitely. If there are more than one error or status present, the lowest number appears as the flash code output. The codes are ordered to have the highest priority condition output first.

The first flash in the six flash sequence indicates if the code that follows is an error bit or a status bit. Error bits flash red and status bits flash yellow. The next five flashes are the binary number of the code (most significant bit first). A red flash indicates a one and a yellow flash indicates a zero. For example, for an error bit six, the binary number is 00110 so the output sequence is:

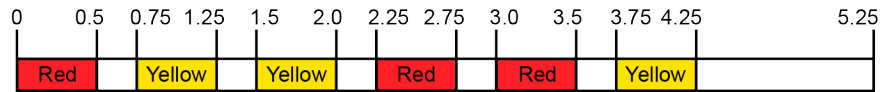

followed by a one second delay. The sequence repeats indefinitely until the receiver is reset.

In the example shown in *Figure 34: Status LED Flash Sequence Example* below, the first flash in the sequence is red, meaning a bit is set in the receiver error word. The next five flashes give a binary value of 00111. Converting this value to decimal results in a value of seven. Therefore, bit seven of the receiver error word is set, indicating a problem with the supply voltage of the receiver's power circuitry.

Figure 34: Status LED Flash Sequence Example

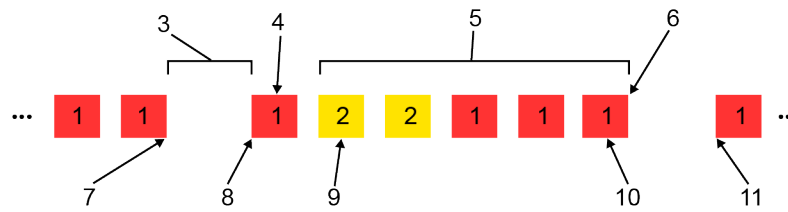

Reference	Description
1	Red
2	Yellow
3	1 Second Pause
4	Word Identifier Flash
5	Bit Identifier Flashes
6	End of Sequence
7	End of Previous Sequence
8	Beginning of Sequence
9	Most Significant Bit of Binary Value
10	Least Significant Bit of Binary Value
11	Start of Next Sequence

Refer to the RXSTATUS log and associated tables in [OEM7 Commands and Logs Reference Manual](#) for more information about this log and receiver error status.

Chapter 5 Ethernet Configuration

This chapter describes how to configure the Ethernet port on an OEM7 receiver. It provides the step-by-step process for connecting to the OEM7 receiver through the Ethernet interface, setting up a base/rover configuration through Ethernet connectivity and utilizing the NTRIP interface. The Ethernet port connections for a computer connected to the receiver are also described for Windows 7 operating systems.



Ethernet is not available on the OEM719.



The **SAVEETHERNETDATA** command can be issued to retain the Ethernet configuration settings after a **RESET/FRESET** command. The **ETHCONFIG** command and **IPCONFIG** command must be issued prior to using **SAVEETHERNETDATA** command. Refer to the [OEM7 Commands and Logs Reference Manual](#).

5.1 Required Hardware

The following hardware is required to set up an Ethernet interface to an OEM7 receiver:

- a user supplied computer with an available Ethernet, serial or USB port
- a GNSS antenna
- an Ethernet capable OEM7 receiver



External Ethernet magnetics are required for the OEM7 receiver cards. The OEM7 Development Kit can be used for Ethernet communication when connected to the OEM7 receiver.

- an RS-232 null modem cable or USB cable
- one or two CAT5 Ethernet cables
- a user supplied Ethernet network, hub or wired router (optional)
- a coaxial antenna cable (50 Ω)

5.2 Static IP Address Configuration

For a static IP address configuration, unique IP addresses are assigned to both the OEM7 receiver and the computer. TCP/IP is used for the connection in this simple network. This configuration can also be used in a bench test environment to confirm Ethernet functionality.

For connections when an OEM7 receiver uses a static IP address configuration, refer to *Figure 35: Cross-Over Ethernet Cable Configuration—OEM7 Receiver* on the next page.

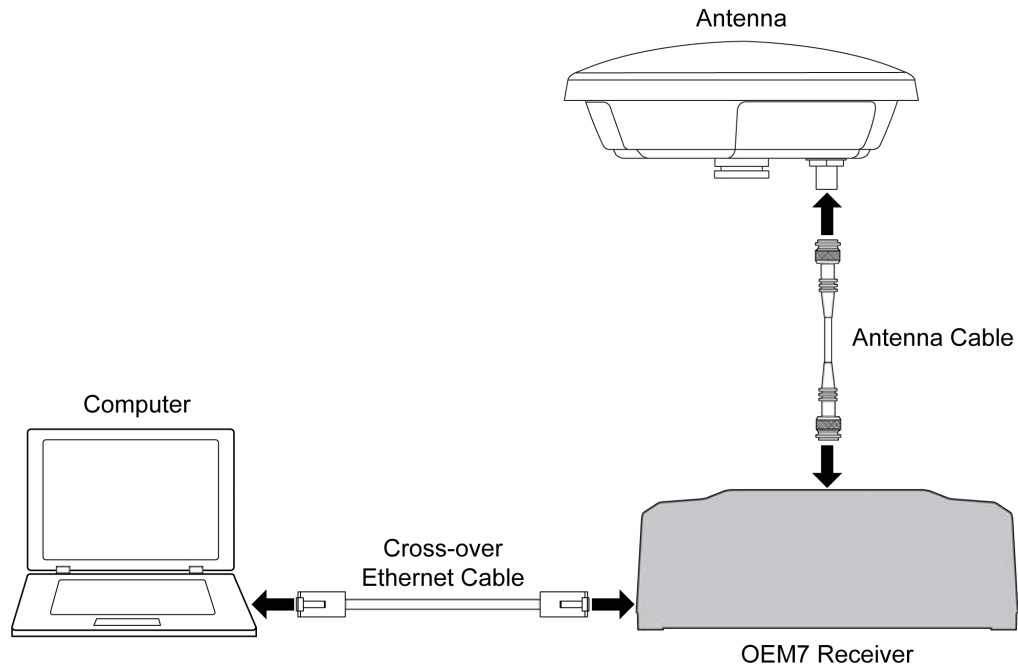
Figure 35: Cross-Over Ethernet Cable Configuration—OEM7 Receiver

5.2.1 Static IP Address Configuration—Receiver

Follow these steps to set up a static IP address on the OEM7 receiver:

1. Connect a computer to the OEM7 receiver using a null modem serial cable or USB cable.
2. Establish a connection to the receiver using either NovAtel Application Suite or another terminal program. This connection is used to send the commands in this procedure to the receiver.



For information about using NovAtel Application Suite, refer to docs.novatel.com/Tools.

3. Enable the Ethernet port on the receiver by entering:

```
ETHCONFIG ETHA AUTO AUTO AUTO AUTO
```

4. Assign the TCP/IP port number used for the connection by entering:

```
ICOMCONFIG ICOM1 TCP :2000
```

5. Assign the receiver IP address, subnet mask and default gateway by entering:

```
IPCONFIG ETHA STATIC 192.168.74.10 255.255.255.0 192.168.74.1
```



The command assigns the following values to the OEM7 receiver:

```
IP address = 192.168.74.10
Subnet mask = 255.255.255.0
Gateway = 192.168.74.1
```

These settings are examples only. The settings appropriate to your system may be different.

6. Save the new Ethernet settings by entering:

```
SAVEETHERNETDATA
```

7. Log the **IPCONFIG** command and confirm the TCP/IP configuration by entering:

```
LOG IPCONFIG ONCE
```

8. Configure your computer with a static IP address.
Refer to *Static IP Address Configuration—Windows 7* below.

5.2.2 Static IP Address Configuration—Windows 7

Follow these steps to set up a static IP address on a computer:

1. Click **Start | Control Panel**.
2. Click **Network and Sharing Center**.
3. Click the **Local Area Connection** link.
The Local Area Connection Status window appears.
4. Click the **Properties** button.
The Local Area Connection Properties window appears.
5. Select **Internet Protocol Version 4 (TCP/IPv4)** and then click the **Properties** button.
The Internet Protocol Version 4 (TCP/IPv4) Properties window appears.
6. Click the **Use the Following IP Address** radio button, then enter the IP address, Subnet mask and Default gateway for the Ethernet port on the computer.



Ensure the Ethernet settings used for the computer are compatible with the Ethernet settings on the OEM7 receiver.

For example, the following settings are compatible with the OEM7 receiver settings used in *Static IP Address Configuration—Receiver* on the previous page:

```
IP address = 192.168.74.11
Subnet mask = 255.255.255.0
Gateway = 192.168.74.1
```

7. Click the **OK** button.
The Local Area Connection Properties window appears.
8. Click the **Close** button.
The Local Area Connection Status window appears.
9. Click the **Close** button.
10. Proceed to *Confirming Ethernet Setup* below.

5.2.3 Confirming Ethernet Setup

1. Connect the computer to the OEM7 receiver using an Ethernet cross-over cable.
See *Figure 35: Cross-Over Ethernet Cable Configuration—OEM7 Receiver* on the previous page.
2. Connect to the receiver using NovAtel Application Suite or any third party terminal program that supports TCP/IP connections. Use the static IP address and port number assigned to the OEM7 receiver in *Static IP Address Configuration—Receiver* on the previous page.

5.3 Dynamic IP Address Configuration

Figure 36: Dynamic IP Address Configuration through a DHCP Server—OEM7 Receiver below shows the connections when an OEM7 receiver uses a dynamic IP address configuration.

Figure 36: Dynamic IP Address Configuration through a DHCP Server—OEM7 Receiver

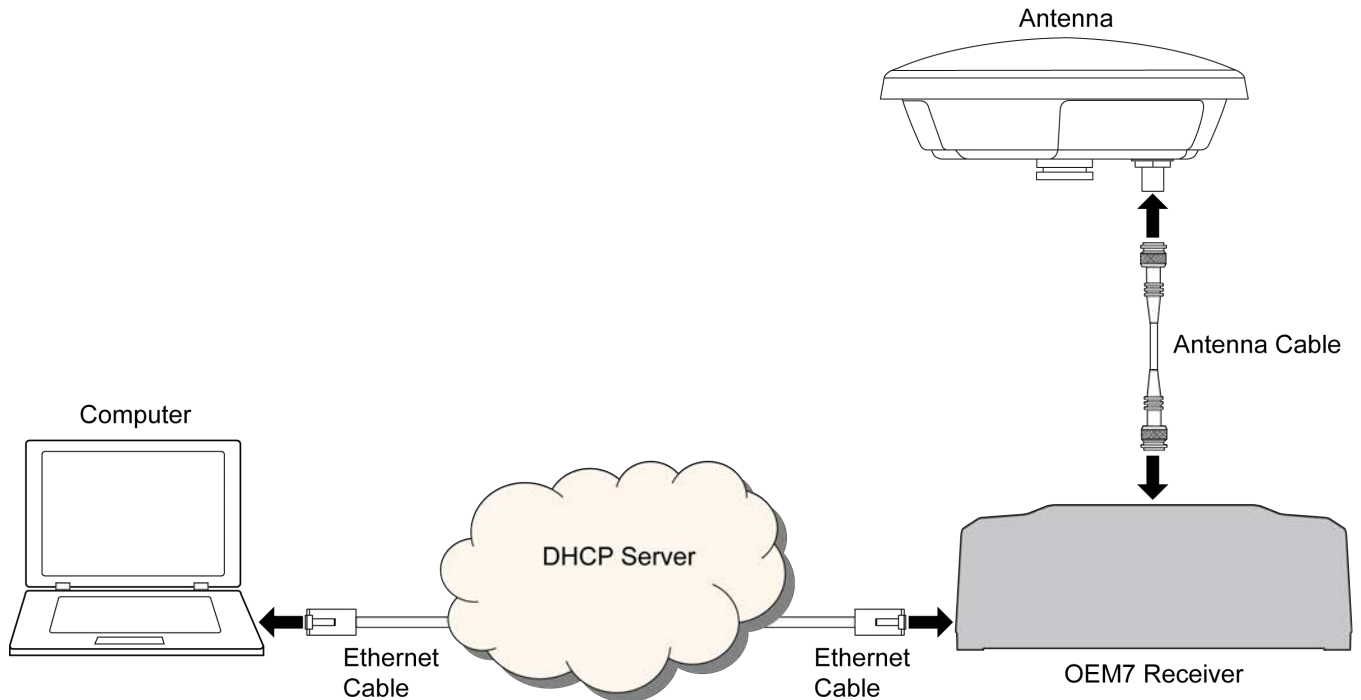

To set up a dynamic IP address configuration, follow these steps:

1. Connect a computer to the OEM7 receiver using a null modem serial cable or USB cable (model dependent).
2. Establish a connection to the receiver using either NovAtel Application Suite or another terminal program. This connection is used to send the commands in this procedure to the receiver.



For information about using NovAtel Application Suite, refer to docs.novatel.com/Tools.

3. Enable the Ethernet port by entering:

```
ETHCONFIG ETHA AUTO AUTO AUTO AUTO
```

4. Obtain the IP address assigned to the OEM7 receiver by the DHCP server.

```
LOG IPSTATUS ONCE
```



Make a note of the IP address returned with this log.

5. Assign the TCP/IP port number by entering:

```
ICOMCONFIG ICOM1 TCP :2000
```

6. Confirm the port number assigned to ICOM1 by entering:

```
LOG ICOMCONFIG ONCE
```

5.4 Base/Rover Configuration through Ethernet Connectivity

You can use an Ethernet connection to provide communication between a base and rover receiver.

Figure 37: Base/Rover Ethernet Setup—OEM7 Receiver below shows the connections when a base and rover OEM7 receiver are connected using Ethernet.

Figure 37: Base/Rover Ethernet Setup—OEM7 Receiver

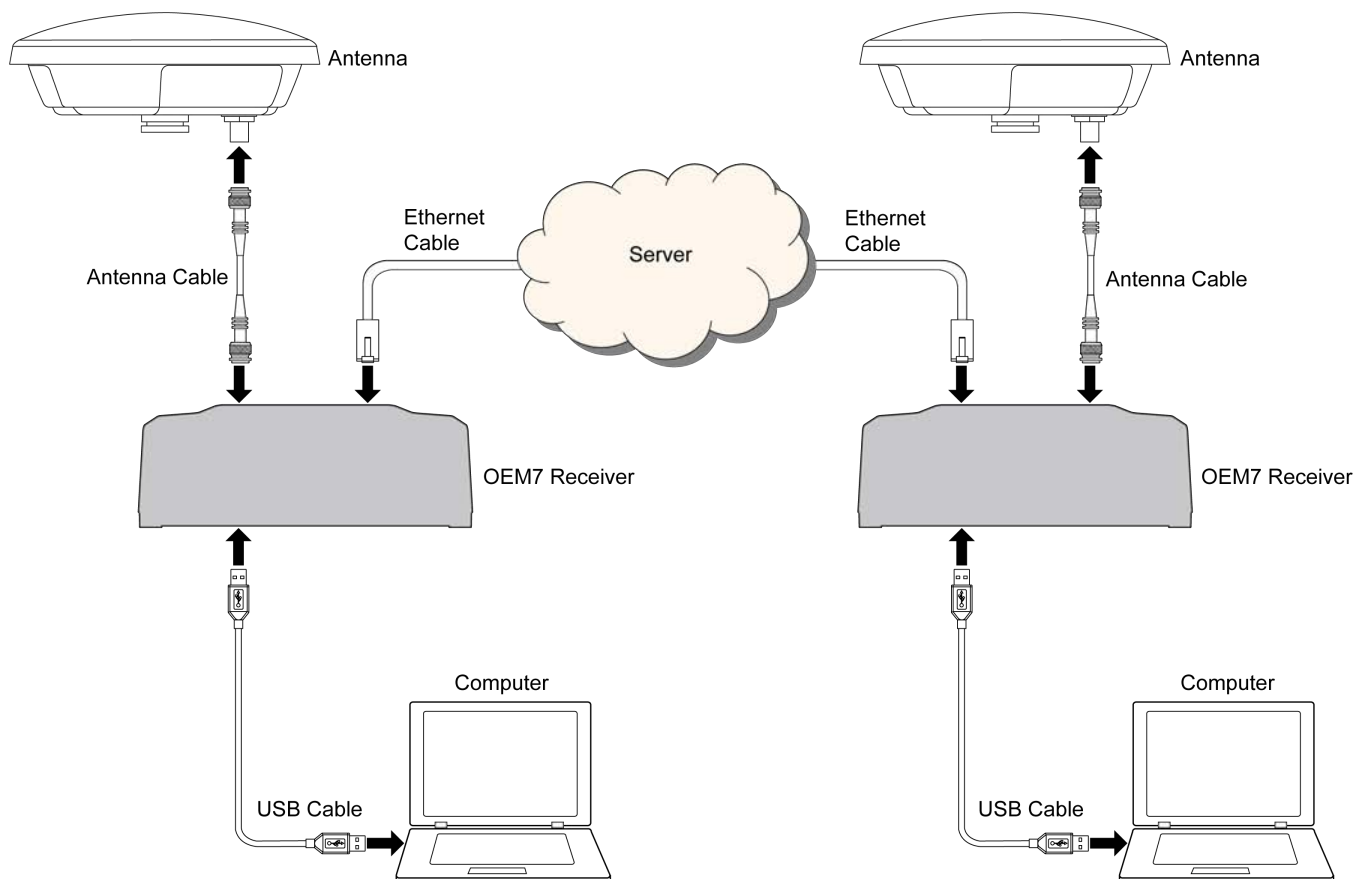

1. Connect your computer to both OEM7 receivers using null modem serial cables or USB cables.
2. Establish a connection to the receiver using either NovAtel Application Suite or another terminal program. This connection is used to send the commands in this procedure to the receivers.



For information about using NovAtel Application Suite, refer to docs.novatel.com/Tools.

3. Connect the power cables to both of the OEM7 receivers and apply power to the receivers.
4. Connect the Ethernet cables to the Ethernet ports on both OEM7 receivers.
5. Establish an Ethernet connection, either static or dynamic configurations. Refer to *Static IP Address Configuration* on page 90 or *Dynamic IP Address Configuration* on the previous page for more information.

6. Send the following commands to each receiver either through serial or USB ports:

Base:

```
FIX POSITION <lat> <long> <height>
INTERFACEMODE ICOM1 NONE RTCA off
LOG ICOM1 RTCAOBS2 ONTIME 1
LOG ICOM1 RTCAREF ONTIME 10
LOG ICOM1 RTCA1 ONTIME 5
SAVECONFIG
```

Rover:

```
ICOMCONFIG ICOM1 TCP <base ip address>:<base port #>
INTERFACEMODE ICOM1 RTCA NONE OFF
LOG BESTPOSA ONTIME 1 (optional)
SAVECONFIG
```

Use the **BESTPOS** log to confirm that the OEM7 rover is in RTK mode.

5.5 Large Ethernet Port Data Throughput

For high data rate Ethernet logging using TCP/IP, disable Windows Delayed Ack Algorithm (DAA) for complete data logging. If you do not disable DAA, there will be data gaps due to the Windows Ethernet buffer.



If done incorrectly, changing the Windows Registry may impair the operation of the computer. Editing the Windows Registry is for advanced Microsoft Windows users only. NovAtel Inc. is not able to provide any technical support for any actions taken regarding information found in Microsoft's Knowledge Base.

Chapter 6 NTRIP Configuration

An Ethernet capable OEM7 receiver can be configured as either an NTRIP server or an NTRIP client. An OEM7 receiver using a Wi-Fi connection can be configured as an NTRIP client. For more information about NovAtel's NTRIP, refer to novatel.com/products/firmware-options-pc-software/gnss-receiver-firmware-options/ntrip.

Figure 38: NTRIP System

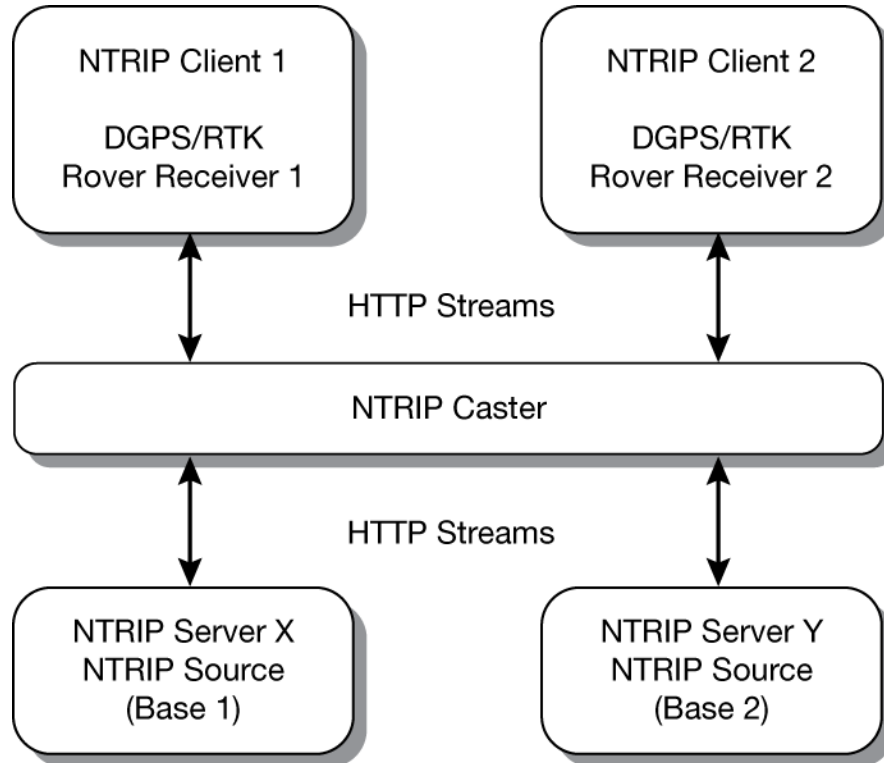

The NTRIP caster is an HTTP internet service that acts as a communication medium between NTRIP servers and NTRIP clients. The NTRIP caster is provided by third party sources. For a full list of NTRIP casters, refer to the following link: <http://www.rtcn-ntrip.org/home>.

6.1 NTRIP Configuration Over Ethernet

The following procedure describes how to configure a NovAtel base and a NovAtel rover through a third party NTRIP caster. This configuration is recommended for optimal RTK performance.

1. Establish a connection to the receiver using either NovAtel Application Suite or another terminal program. This connection is used to send the commands in this procedure to the receiver.



For information about using NovAtel Application Suite, refer to docs.novatel.com/Tools.

2. Connect the Ethernet cable to the Ethernet ports on both OEM7 receivers. For this setup, use a cross-over Ethernet cable.
3. Establish a static or dynamic Ethernet connection.
For information about creating the connection, refer to *Static IP Address Configuration* on page 90 or

Dynamic IP Address Configuration on page 93.

4. Use the following commands to enable the base receiver as an NTRIP Server:

```
NTRIPCONFIG NCOM1 SERVER V2 <endpoint> <mountpoint> <username>
<password> ETHA
INTERFACEMODE NCOM1 NONE RTCA OFF
FIX POSITION <lat> <long> <height>
LOG NCOM1 RTCAOBS2 ONTIME 1
LOG NCOM1 RTCAREF ONTIME 10
LOG NCOM1 RTCA1 ONTIME 1
SAVECONFIG
```

5. Use the following commands to enable the rover receiver as an NTRIP Client:

```
ETHCONFIG ETHA AUTO AUTO AUTO AUTO
NTRIPCONFIG NCOM1 CLIENT V1 <endpoint> <mountpoint> <username>
<password > ETHA
```



If using a specific Network RTK system, certain National Marine Electronics Association (NMEA) strings are required to be sent from the rover back to the RTK network. For example, if connected to the VRS mount point, the rover is required to send its position to the network in a standard NMEA GGA message. This is achieved by issuing the following commands: **LOG NCOMx GPGGA ONTIME 5**, until data is received by the caster. For more information about Network RTK options and properties, refer to the application note [APN-041 Network RTK](#) and [APN-074: NTRIP on NovAtel OEM6/OEM7](#).

The following is an NTRIP Client configuration example without the use of a Network RTK system:

```
INTERFACEMODE NCOM1 RTCA NONE OFF
RTKSOURCE AUTO ANY
PSRDIFFSOURCE AUTO ANY
LOG BESTPOS ONTIME 1 (optional)
SAVECONFIG
```



Refer to the **NTRIPCONFIG** command in the [OEM7 Commands and Logs Reference Manual](#) for further command details.

Chapter 7 CAN Bus

The OEM7 receivers support the following CAN protocols:

- J1939 Transport and Extended Transport Protocol: used for corrections and NovAtel messages (both transmitting and receiving)
- NMEA2000: used for standard as well as NovAtel-proprietary messages (transmitting only)

By default, CAN is disabled on OEM7 receivers. Critical CAN configuration parameters such as Parameter Group Numbers (PGNs), addresses and priorities are system-specific and must be explicitly configured.

The addresses and PGNs are typically allocated when the overall CAN bus topology is determined. Because the OEM7 receiver can operate on 2 CAN buses concurrently, it can run 0, 1 or 2 CAN Nodes. A Node has a unique CAN J1939 NAME and address.



There are no CAN transceivers on the OEM7 receiver cards. These cards require external CAN transceivers and proper bus terminations. See *CAN Controller Ports* on page 245 for an example of a CAN transceiver circuit.



On the OEM719, CAN1 is multiplexed with user VARF and EVENT2, so the following commands must be issued before enabling CAN1:

```
EVENTOUTCONTROL MARK1 DISABLE  
EVENTINCONTROL MARK2 DISABLE
```

Refer to *OEM719 Interface Connector* on page 150, *OEM729 Interface Connectors* on page 167, *OEM7600 Interface Connector* on page 185, *OEM7700 Interface Connector* on page 207 and *OEM7720 Interface Connector* on page 230 for pin-out information.

OEM7 receivers support the following NMEA2000 Parameter Group Messages (PGN) over the CAN bus:

- PGN 126992 System Time
- PGN 129025 GNSS Position Rapid Update
- PGN 129026 COG & SOG Rapid Update
- PGN 129027 Position Delta High Precision Rapid Update
- PGN 129029 GNSS Position
- PGN 129551 GNSS Differential Signal

The following commands and logs are used for CAN configuration:

- **CANCONFIG** command: controls the CAN transceiver hardware and places the receiver *on bus* or *off bus*
- **J1939CONFIG** command: assigns the CAN J1939 NAME and address parameters to a Node
- **J1939STATUS** log: reports the status a Node on the J1939 CAN network, such as the claimed address
- **LOG CCOMx PGNabcd**: configures the NMEA2000 messages
- **CCOMCONFIG** command: configures the parameters used by the NovAtel command interface to interact with the CAN Bus.



CCOM ports with a lower port number have a higher transmission priority.



For information about these commands, see the [OEM7 Commands and Logs Reference Manual](#).



Details for the PGN messages can be found in the NMEA2000 specification which can be purchased directly from the National Marine Electronics Association (www.nmea.org/).

7.1 Default Configuration

After a FRESET, the receiver has the following CAN configuration:

- All CAN physical ports are disabled
- No J1939 addresses are claimed
- CCOM ports are configured for NMEA2000 messages only

Table 8: Default NAME

Parameter	Value
Address	0x1C
Industry Group	2
Device Class	0
Device Class Instance	0
Function	23
Function Instance	0
ECU Instance	0
Manufacturer Code	305

7.2 Configuring the CAN Bus

To enable an OEM7 receiver to communicate over the CAN bus, configure CAN and place the receiver *on bus*, triggering a *J1939 Address Claim Procedure*.

1. Use the **J1939CONFIG** command to specify J1939 NAME and desired address.

This step is optional and only required if the default NAME parameters are to be changed.

2. Use the **CANCONFIG** command to place the receiver *on bus*.
3. Optionally, use the **J1939STATUS** log to monitor CAN status on the receiver.

7.2.1 Configuration Notes

- The **J1939CONFIG** and **CANCONFIG** commands can be entered in any order. After the **CANCONFIG** command is used to place the receiver on the CAN bus, **J1939CONFIG** commands take effect immediately. Until then, J1939CONFIG can be entered many times to change the settings because they have not taken affect yet (the receiver is not yet on the bus).

- The J1939 Address claim procedure is executed if and only if both J1939CONFIG NODEx CANx and CANCONFIG CANx ON are entered.
- Use J1939STATUS log to determine the receiver's CAN status and the actual address claimed by a particular node.
- Once the receiver is "on bus", it must be taken "off-bus" using CANCONFIG for any further configuration changes using J1939CONFIG.
- The receiver is fully "on-bus" only once the J1939 address has been successfully claimed. This is reported as "CLAIMED" status by J1939STATUS log.
- No messages will be sent or received until the receiver is "online" and an address is claimed. Outgoing messages are not buffered; they are discarded until the receiver is online.

7.2.2 Example of Enabling the CAN Bus

1. LOG J1939STATUS ONCHANGED
2. J1939CONFIG NODE1 CAN1 <addresses>
3. CANCONFIG CAN1 ON 250K
4. SAVECONFIG
 - < J1939STATUS NODE1 DISABLED 0 0xFE
 - < J1939STATUS NODE1 CLAIMING 1 <address>
 - < J1939STATUS NODE1 CLAIMED <attempt count> <address>

7.2.3 Example of Modifying the CAN Bus Parameters

1. LOG J1939STATUS ONCHANGED
2. CANCONFIG CAN1 OFF
3. J1939CONFIG NODE1 CAN1 <addresses>
4. CANCONFIG CAN1 ON
5. SAVECONFIG
 - < J1939STATUS NODE1 DISABLED 0 0xFE
 - < J1939STATUS NODE1 CLAIMING 1 <address>
 - < J1939STATUS NODE1 CLAIMED <attempt count> <address>

7.2.4 Example of Detecting an Address Claim Failure and Reconfiguring

1. LOG J1939STATUS ONCHANGED
2. J1939CONFIG NODE1 CAN1 <addresses>
3. CANCONFIG CAN1 ON
 - < J1939STATUS NODE1 DISABLED 0 0xFE
 - < J1939STATUS NODE1 CLAIMING 1 <address>
 - < J1939STATUS NODE1 FAILED <attempt count> 0xFE
4. CANCONFIG CAN1 OFF
 - < J1939STATUS NODE1 DISABLED 0 0xFE
5. J1939CONFIG NODE1 CAN1 <addresses>

6. CANCONFIG CAN1 ON

```
< J1939STATUS NODE1 CLAIMING 1 <address>
< J1939STATUS NODE1 CLAIMED <attempt count> <address>
```

7.2.5 Address Claim Procedure

To become operational on the CAN bus, an OEM7 receiver must claim a J1939 address. The preferred address and a range of alternative addresses are specified using the **J1939CONFIG** command. When a configured receiver is placed *on bus*, it may make multiple attempts to claim an address. It may also have its address bumped by a higher priority device claiming the same address.

While the device is attempting to claim an address, the **J1939STATUS** log reports a status of *CLAIMING* and automatically tries to claim the next allowed address. Depending on the **J1939CONFIG** parameters, an address different from the **J1939CONFIG** *preferred address* may be claimed or the address claim procedure can fail entirely. If no addresses could be claimed, a *FAILED* status is reported and the receiver takes no further action. To recover from this failure, take the receiver *off bus* using the **CANCONFIG** command and change the CAN address configuration using the **J1939CONFIG** command.

The address can also be assigned using J1939 *Commanded Address* message sent by another ECU on the bus, such as a tester unit. The commanded address always overrides the address specified using **J1939CONFIG** command. When the *Commanded Address* is received, the receiver reports a status of *CLAIMING* followed by *CLAIMED*. Restarting CAN using the **J1939CONFIG** command or **CANCONFIG** command clears the commanded address; the Address Claim procedure will be executed again based on parameters specified in the **J1939CONFIG** command.

7.3 NMEA2000 Logging

OEM7 receivers support both a subset of the standard NMEA2000 PGNs, as well as NovAtel proprietary PGNs.

All NMEA2000 logs are configured using the **LOG** command, where the COM port is a CAN port (CCOM). The CCOM port must be associated with a J1939 node using the **CCOMCONFIG** command. If only NMEA2000 logs are needed, **CCOMCONFIG** parameters other than J1939NODE may be ignored.

To enable NMEA2000 logs:

1. Configure the CAN bus. See *Configuring the CAN Bus* on page 99.
2. Enable the CCOM port on the CAN bus node using the **CCOMCONFIG** command.
3. Enable the desired NMEA2000 logs.

NMEA2000 logs can be requested regardless of the on/off bus status of the receiver or the J1939 configuration. They are output if and only if the receiver is online.



The position for the **PGN129025**, **PGN129027** and **PGN129029** logs are reported in the user selected datum. See the **OUTPUTDATUM** command for more details.



When the solution type is INS (SPAN models), the DOPs in the PGN129029 message are calculated at a 1 Hz rate.
To determine if the receiver is providing an INS solution, check the **pos type** field in the **BESTPOS** log.

7.3.1 Example of NMEA2000 Log Configuration

1. `CCOMCONFIG CCOM1 NODE1 NMEA2000`
2. `LOG CCOM1 PGN129025 ONTIME 0.5`
3. `LOG CCOM1 PGN129026 ONTIME 0.25`
4. `SAVECONFIG`

7.4 Corrections Over CAN

All NovAtel supported correction types are supported over CAN ports (CCOM).

To send or receive corrections:

1. Configure the CAN Bus. See *Configuring the CAN Bus* on page 99.
2. Use the **CCOMCONFIG** command to configure the PGN and other CAN parameters used by the RTK corrections CAN messages.

PGN: Use the PGN designated for corrections.

Address:

- Use 0xFF to receive corrections from any CAN address and to broadcast corrections to all CAN nodes.
 - Use 0x00 to 0xFE to send corrections to or receive corrections from a specific CAN node.
3. Use the **INTERFACEMODE** command to configure the CCOM interface mode.
 - To transmit corrections, use the desired INTERFACEMODE, e.g. RTCMV3
 - To receive corrections, it is recommended to use INTERFACEMODE AUTO.



Corrections configuration (**CANCONFIG** and **INTERFACEMODE**) for a particular CCOM port do not affect its NMEA2000 configuration. NMEA2000 logs coexist with correction messages, both incoming and outgoing.

7.4.1 Example for Receiving Corrections from Any Source

1. `CCOMCONFIG CCOM2 NODE1 J1939 61184 6 0xFF`
2. `INTERFACEMODE CCOM2 AUTO NONE OFF`

7.4.2 Example for Transmitting Corrections to 0x1C Node

1. `CCOMCONFIG CCOM2 NODE1 J1939 61184 6 0x1c`
2. `INTERFACEMODE CCOM2 NONE RTCMV3 OFF`

7.5 NovAtel Messages Over CAN

Standard NovAtel messages (commands, logs, responses) can be sent and received on the CAN Bus using CAN ports (CCOM). To reduce CAN Bus loading, NovAtel messages are sent using NovAtel standard binary format over J1939 (default).

The CCOM port requires special configuration and has the following limitations:

- A single CCOM port cannot be used for both Binary and ASCII / NovAtel ASCII messages.
- A single CCOM port cannot be used for both Binary messages and corrections.
- If the CCOM port is configured as *NOVATEL*, all input is interpreted as NovAtel ASCII or Abbreviated ASCII. Unlike other COM ports, the receiver will not distinguish between ASCII and binary input.
- To use CAN NOVATELBINARY, the CCOM port must be placed into NOVATELBINARY using the **INTERFACEMODE** command.



It is recommended to use one dedicated CCOM port for NovAtel messages and another dedicated CCOM port for corrections.



NovAtel UI configuration does not affect NMEA2000. Any CCOM port can be used for NMEA2000 logs irrespective of CCOMCONFIG settings.

To configure NovAtel User Interface over CAN:

1. Configure the CAN Bus. See *Configuring the CAN Bus* on page 99.
2. Use the **CCOMCONFIG** command to configure the PGN and other CAN parameters.
3. Use the **INTERFACEMODE** command to configure the CCOM port for **NOVATELBINARY**.

Example: Configuring CCOM2 for NovAtel messages:

1. **CCOMCONFIG CCOM2 NODE1 1234 6 0x1C**
2. **INTERFACEMODE CCOM2 NOVATELBINARY NOVATELBINARY OFF**

7.6 Configuring OEM7 Receivers to Use OEM6 CAN Settings

CAN Bus functionality has been enhanced on OEM7 receivers. To accommodate the enhancements in functionality and flexibility, several new commands and logs have been added. Also, the **SETCANNAME** command has been removed and the **CANCONFIG** command has been modified.

The following sections describes how to configure CAN on OEM7 receivers to operate like OEM6 receivers.

7.6.1 Configuration on OEM6

On OEM6 receivers, the **SETCANNAME** command, with minimal parameters, could be used to configure CAN.

```
SETCANNAME 305
```

Once entered, a limited address claim procedure would take place and NMEA2000 logs would be generated automatically at a fixed logging rate and fixed CAN port bit rate.

7.6.2 Configuration on OEM7

To configure an OEM7 receiver to log the same commands and use the same logging rate and CAN port bit rate, enter the following commands:

```
CCOMCONFIG CCOM1 NODE1 NMEA2000
CANCONFIG CAN1 ON 250K
LOG CCOM1 PGN129025 ONTIME 0.1
LOG CCOM1 PGN129026 ONTIME 0.1
```

```
LOG CCOM1 PGN129027 ONTIME 0.1
LOG CCOM1 PGN129029 ONTIME 1.0
SAVECONFIG
```

On OEM7 receivers, nothing is automatically logged when CAN is enabled. Regular log requests must be made for each log required.

A full address claim procedure with default values is initiated with the **CANCONFIG ON** command. The J1939CONFIG command can be used to modify the default address claim parameters including the ManufacturingCode (set to 603 in the SETCANNNAME example above, now defaults to 305 in the new J1939CONFIG) but it's not necessary.

Chapter 8 Troubleshooting

There are simple ways to diagnose and resolve problems. In many cases, the issue can be resolved within a few minutes, avoiding the inconvenience and loss of productivity that results from having to return the receiver for repair. This section discusses troubleshooting issues and includes cross-references to other sections of the manual that may help resolve problems.

If unsure of the symptoms or if the symptoms do not match any of those listed, use the RXSTATUS log to check the receiver status and error words. See *Examining the RXSTATUS Log* on the next page.

Try to resolve the problem using the troubleshooting guide in *Table 9: Troubleshooting Based on Symptoms* below, then try our Knowledge Base at novatel.com/support. If you are still not able to resolve the problem, see *Customer Support* on page 17 for troubleshooting logs and contact information.

Table 9: Troubleshooting Based on Symptoms

Symptom	Related Section
The receiver is not properly powered	Check the power cable. Replace if faulty. See <i>Power Supply Requirements for Receiver Cards</i> on page 30
The receiver cannot establish communication	Check the serial cables and ports. Replace if faulty. See <i>CAN Bus</i> on page 98 and <i>Status LED</i> on page 88. Refer also to the SERIALCONFIG command.
The receiver is not tracking satellites	Ensure that the antenna has an unobstructed view of the sky from horizon to horizon. Check the RXSTATUS error states. See <i>Examining the RXSTATUS Log</i> on the next page. If the receiver is in error mode, it does not track. Use the Interference Toolkit to check if there is an interference signal present. See <i>Interference Toolkit</i> on page 76. Check the antenna cable. Replace if faulty. See <i>Selecting a GNSS Antenna</i> on page 29, <i>Choosing a Coaxial Cable</i> on page 30 and <i>Connecting the Antenna to the Receiver Card</i> on page 46.
No data is being logged	Refer to <i>CAN Bus</i> on page 98 and <i>Communications with the Receiver</i> on page 55
Random data is being output by the receiver or binary data is streaming	Check the baud rate on the receiver and in the communication software. Refer to the SERIALCONFIG command and FRESET command. See also <i>CAN Bus</i> on page 98.
A command is not accepted by the receiver	Check for correct spelling and command syntax. See <i>Communications with the Receiver</i> on page 55 and refer to the FRESET command in the OEM7 Commands and Logs Reference Manual

Symptom	Related Section
Differential mode is not working properly	See <i>Transmitting and Receiving Corrections</i> on page 60 and refer to the SERIALCONFIG command.
There appears to be a problem with the receiver's memory	Refer to the NVMRESTORE command.
An environmental or memory failure. The receiver temperature is out of acceptable range or the internal thermometer is not working	<p>Move the receiver to within an acceptable temperature range. See:</p> <ul style="list-style-type: none"> • <i>High Temperature Environments</i> on page 110 • <i>OEM719 Electrical and Environmental Specifications</i> on page 144 • <i>OEM729 Electrical and Environmental Specifications</i> on page 160 • <i>OEM7600 Electrical and Environmental Specifications</i> on page 179 • <i>OEM7700 Electrical and Environmental Specifications</i> on page 201 • <i>OEM7720 Electrical and Environmental Specifications</i> on page 224
Overload and overrun problems. Either the CPU or port buffers are overloaded	Reduce the amount of logging or increase the baud rate. See also <i>Table 4: OEM7 Card Default Serial Port Configurations</i> on page 47.
The receiver is indicating that an invalid authorization code has been used	Refer to the VERSION log or VALIDMODELS log and the MODEL command or AUTH command.
The receiver is being affected by jamming	Move the receiver away from any possible jamming sources
The receiver is being affected by interference	<p>See <i>Interference Toolkit</i> on page 76.</p> <p>Move the GNSS antenna away from the source of the interference signal.</p> <p>If the interference mitigation feature is enabled on the receiver, configure a filter within the Interference Toolkit to filter out the interference signal.</p>
The receiver's Automatic Gain Control (AGC) is not working properly	See the jamming symptom in this table

For information about the commands and logs in this section, refer to the [OEM7 Commands and Logs Reference Manual](#).

8.1 Examining the RXSTATUS Log

The RXSTATUS log provides detailed status information about your receiver and can be used to diagnose problems. Refer to the **RXSTATUS** log for details on this log and on how to read the receiver error word and status word. *Table 10: Resolving a Receiver Error Word* on the next page, *Table 11: Resolving an Error in the Receiver Status Word* on page 108 and *Table 12: Resolving an Error in the AUX1 Status Word* on page 109

have actions to take when your receiver has an error flag in these words. If you are not able to resolve the condition, contact *Customer Support* on page 17.

Table 10: Resolving a Receiver Error Word

Bit Set	Action to Resolve
0-2	Issue a FRESET command (for bit 1, reload new firmware).
4	Contact <i>Customer Support</i> on page 17.
5	Check the VERSION log. The VERSION log will indicate "Invalid authcode". Upgrade the auth-code as described in <i>Upgrading Using an Auth-Code</i> on page 132.
6	Issue a FRESET command
7	See <i>Power Supply Requirements for Receiver Cards</i> on page 30
8	Reserved
9	<p>Check the temperature ranges in:</p> <ul style="list-style-type: none"> • <i>OEM719 Electrical and Environmental Specifications</i> on page 144 • <i>OEM729 Electrical and Environmental Specifications</i> on page 160 • <i>OEM7600 Electrical and Environmental Specifications</i> on page 179 • <i>OEM7700 Electrical and Environmental Specifications</i> on page 201 • <i>OEM7720 Electrical and Environmental Specifications</i> on page 224 <div style="border: 1px solid black; padding: 10px; margin-top: 10px;">  <p>The operating temperatures are ambient air temperatures. The temperature sensors on the receiver PCB will reflect higher operating temperatures (refer to the HWMONITOR log). The PCB temperature sensors will trigger a receiver warning and receiver error at 100°C and 110°C respectively. The warning and error conditions are captured using the RXSTATUS log.</p> </div>
10	Possible hardware or environmental condition. If you cannot resolve the problem, contact <i>Customer Support</i> on page 17.
11	<p>Possible hardware or environmental condition. If you cannot resolve the problem, contact <i>Customer Support</i> on page 17.</p> <p>Also, check the Auxiliary 2 Status word to determine which PLL is in error.</p>
12-14	Reserved
15	Issue a FRESET command and power cycle the unit. If the bit is still present, contact <i>Customer Support</i> on page 17.
16	Monitor CPU idle time. Reduce number of logs or the rate of data logging.
17	Ensure that the Version log is consistent with the hardware.
18-19	Reserved
20	SoftLoad is in progress. See <i>Updating Using SoftLoad Commands</i> on page 119.

Bit Set	Action to Resolve
21	You may be exceeding the receiver's velocity limit. If so, reduce velocity. This error can only be cleared by resetting the receiver.
22	Reload firmware using WinLoad or the SoftLoad commands.
23-30	Reserved
31	Possible hardware failure. Contact <i>Customer Support</i> on page 17.

Table 11: Resolving an Error in the Receiver Status Word

Bit Set	Action to Resolve
0	Check the Error Word in the RXSTATUS log. See also <i>Table 10: Resolving a Receiver Error Word</i> on the previous page
1	Check the temperature ranges in <ul style="list-style-type: none"> • <i>OEM719 Electrical and Environmental Specifications</i> on page 144 • <i>OEM729 Electrical and Environmental Specifications</i> on page 160 • <i>OEM7600 Electrical and Environmental Specifications</i> on page 179 • <i>OEM7700 Electrical and Environmental Specifications</i> on page 201 • <i>OEM7720 Electrical and Environmental Specifications</i> on page 224
2	See <i>Power Supply Requirements for Receiver Cards</i> on page 30
3	See <i>Selecting a GNSS Antenna</i> on page 29, <i>Choosing a Coaxial Cable</i> on page 30, <i>Connecting the Antenna to the Receiver Card</i> on page 46, <i>Antenna LNA Power</i> on page 47
4	
5	
6	
7	Check the CPU idle time. Check for unnecessary logging. Check for simultaneous use of functionality.
8	See <i>Table 7: Serial Ports Supported</i> on page 57 Also, check the Auxiliary 2 Status word to determine which COM port has overrun its buffer.
9-11	Reserved
15	Check the Auxiliary 1 status word to determine which RF channels are jammed.
16-17	Reserved
18	When the receiver has tracked GNSS satellites long enough for a valid almanac to be received, this bit will be set to 0.
19	None. This bit only indicates if the receiver has calculated a position.
20	None. This bit is a status bit indicating if the receiver's position has been manually fixed and does not represent a problem. Refer also to the FIX command.

Bit Set	Action to Resolve
21	None. This bit indicates if clock steering has been manually disabled. Refer also to the FRESET command.
22	None. This bit only indicates if the clock model is valid. Refer also to the FRESET command.
23	None. This bit indicates if the phase-lock-loop is locked when using an external oscillator. Refer also to the FRESET command.
24	Check the CPU idle time. Check for unnecessary logging. Check for simultaneous use of functionality.
25-26	None. These bits identify the receiver family. For OEM7 receivers, bit 25 is set to 1 and bit 26 is set to zero.
27	Interference Toolkit HDR mode status. When this bit is set to 1, Interference Toolkit HDR mode is enabled.
28	Digital filter status. When this bit is set to 1, an Interference Toolkit digital filter is enabled.
29	None. This bit indicates if any bits in the auxiliary 3 status word are set. The auxiliary 3 word provides status information and does not contain any new information on problems. Refer also to the FRESET command.
30	None. This bit indicates if any bits in the auxiliary 2 status word are set. The auxiliary 2 word provides status information and does not contain any new information on problems. Refer also to the FRESET command.
31	None. This bit indicates if any bits in the auxiliary 1 status word are set. The auxiliary 1 word provides status information and does not contain any new information on problems. Refer also to the FRESET command.

For information about the commands and logs in this section, refer to the [OEM7 Commands and Logs Reference Manual](#).

8.2 Examining the AUX1 Status Word

Table 12: Resolving an Error in the AUX1 Status Word below provides actions to take when your receiver has an error flag in the AUX1 status word.

Table 12: Resolving an Error in the AUX1 Status Word

Bit Set	Action to Resolve
0-2	Jammer detected
3	None. This bit indicates that Position Averaging is ON
4-6	Jammer detected
7	Connect the receiver via USB
8-10	Reduce the amount of logging on the USB ports

Bit Set	Action to Resolve
11	(Reserved bit)
12	None. This bit indicates a Profile set using the PROFILE command is activated.
13	Throttled Ethernet Reception Check for unusually high Ethernet traffic being directed to the Receiver. This does not represent an error condition on the receiver, but suggests there may be an issue in the network environment on the receiver.
14-17	AGC error on RF1 through RF4 respectively. To resolve, ensure the antenna cable is connected and signal input level is within specification. Contact NovAtel <i>Customer Support</i> on page 17 for additional information.
18	Connect the receiver via Ethernet. See <i>Ethernet Ports</i> on page 52
19-21	Reduce the amount of logging on the Ethernet ports
22-24	Reduce the amount of logging on the NTRIP ports
25-27	Reduce the amount of logging on the Virtual COM ports
28-29	AGC error on RF5 (bit 28) or RF6 (bit 29). To resolve, ensure the antenna cable is connected and signal input level is within specification. Contact NovAtel <i>Customer Support</i> on page 17 for additional information.
30-31	(Reserved bits)

8.3 High Temperature Environments

The operating temperature of OEM7 receivers increases as more features (channels used, HDR mode, etc.) are enabled.

When the receiver is operating in an environment that is near its maximum ambient temperature, an increase in the ambient air temperature or enabling additional features may cause the receiver to exceed its maximum operating temperature and generate a Temperature Status error. When a Temperature Status error occurs, the receiver idles all channels, turns off the antenna and disables the RF hardware. The communication interfaces continue to function so commands can be sent and logs received.

8.3.1 Indicators of an Error State

The indications that the receiver is in an error state, such as a Temperature Status error, are:

- Logs that have a solution status will show `INSUFFICIENT_OBS` as the Solution Status.
- The **RXSTATUSEVENT** log is output on all communication ports. This log will indicate an error condition in the Receiver Error word of the log.
- The Error strobe is set high and Status LED flashes red and yellow showing an error code.
- All logs output have Bit 0 set in the Receiver Status word of the log header.

To determine the cause of the error, log the **RXSTATUS** log and check the Receiver Error word. If Bit 9 is set, it is a Temperature Status error. For information about reading the Error Word, refer to *Error Word* on page 87.

8.3.2 Recovering from a Temperature Status Error

The receiver must be reset or power cycled to recover from a receiver error such as a Temperature Status error.

Log information is lost when the receiver is reset. Therefore, any logs required to identify and troubleshoot the error, such as the **RXSTATUS** log, should be collected before resetting the receiver.

Also, steps should be taken to reduce the cause of the receiver temperature error to prevent the error from occurring again. See *Mitigating High Receiver Temperature* below.

8.3.3 Mitigating High Receiver Temperature

If the receiver has a high temperature warning or error, use one or more of the following suggestions to reduce the receiver temperature.

- If possible, reduce the ambient temperature around the receiver or move the receiver to an area with a lower ambient temperature.
- Disable the receiver features that are not required for the current operation of the receiver.
- On OEM7 receiver cards, the method used to mount the card can help with thermal dissipation. Refer to *Thermal Dissipation* on page 38 for more information.
- On the OEM7720, a heat spreader is available to assist with thermal dissipation. Refer to *OEM7720 Accessory Heat Spreader* on page 38 for more information.

8.3.4 Monitoring the Receiver Temperature

If the receiver is operating in a high ambient temperature environment, you can monitor the receiver temperature using the RXSTATUS and HWMONITOR logs.

1. Log the **RXSTATUS** log and check Bit 1 of the Receiver Status word.

```
LOG RXSTATUS onchanged
<RXSTATUS USB1 0 81.5 FINESTEERING 1990 326146.020 0a104020 2ae1 14434
< 00000000 5
< 0a104020 00000000 00030000 00030000 (Receiver Status)
< 00062000 00001008 00000000 00000000
< 00000000 00000000 80000000 00000000
< 80000000 00000000 00000000 00000000
< 00000000 00000000 00000000 00000000
```

For information about reading the Receiver Status word, refer to *Status Word* on page 86.

2. If Bit 1 is 0, the temperature is okay. Continue monitoring, but no action is required.
If Bit 1 is 1, the receiver temperature has exceeded the warning limit.
3. Log the **HWMONITOR** log and check the two temperature status fields (0x01 and 0x16).

```
LOG HWMONITOR ontime 30
<HWMONITOR USB1 0 77.5 FINESTEERING 1990 326851.000 0a104020 52db 14434
< 10
< 58.424915314 100 (Temperature 0x01)
< 0.000122100 200
< 3.296703339 600
< 5.169230938 700
< 1.192307711 800
< 3.300366402 f00
< 1.833943844 1100
```

```

<      5.159462929 1500
<      1.555555582 1700
<      58.485961914 1600 (Temperature 0x16)

```

Pay attention to the reading and the boundary limit status.

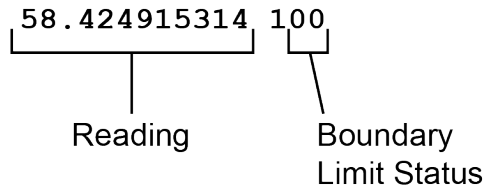

Refer to Table: HWMONITOR Status Table in the **HWMONITOR** log section for a description of the Boundary Limit Status.

4. Use the suggestions in *Mitigating High Receiver Temperature* on the previous page to reduce the receiver temperature.
5. Continue monitoring the **HWMONITOR** log to see if receiver temperature is dropping.
6. Check the **RXSTATUS** log to see if the temperature status changes to Okay (Bit 1 in the Receiver Status word changes to 0).

8.4 Safe Mode

Safe Mode is an error condition triggered on the OEM7 receiver if it encounters certain critical problems during start-up. The receiver does not track GNSS satellites in this state, but the user interface is still available to allow for diagnosis of the problem.

The receiver will enter Safe Mode under certain rare cases including the following:

- Corrupted or bad data within the receiver Non-Volatile Memory (NVM).
- An unsupported Auth Code.
- The expected main firmware image could not be found by the boot code. This is possibly due to an error during the main firmware loading process (i.e. WinLoad, SoftLoad, etc.).

Safe Mode exists to allow users to take steps to recover the receiver after such an error occurs. Potential recovery steps are described in *Recovery Steps* below.

Safe Mode is indicated by an error bit in the **RXSTATUS** log.

8.4.1 Reset Loop Detection

In order to determine when the Safe Mode error should be triggered, OEM7 receivers have the ability to detect when an unexpected reset has occurred during the boot process. If a Reset Loop is detected, the **Reset Loop Detected** bit is set in the **RXSTATUS** log.

This bit is only a warning and the receiver may still be able to operate correctly. The receiver will allow several unexpected resets to occur before triggering the Safe Mode Error, at which point the receiver will not track GNSS satellites.

8.4.2 Recovery Steps

If the **Safe Mode** error bit or the **Reset Loop Detected** warning bit are set in the **RXSTATUS** log, take the following steps to diagnose and recover the system:

1. Request the **SAFEMODESTATUS** log and determine the current *Safe Mode State* of the system.
2. Reference Table: Safe Mode States in the [OEM7 Commands and Logs Reference Manual](#) and find the suggested actions for the current Safe Mode State.
3. If the suggested actions do not resolve the issue, contact NovAtel Customer Support.

Chapter 9 NovAtel Firmware

Download the most recent versions of the NovAtel firmware from the novatel.com/support/support-materials/firmware-download.

NovAtel firmware runs on NovAtel receivers. It provides the features and functionality available on the receiver.

The firmware download file contains:

- Firmware *.shex file
- WinLoad software utility

9.1 Firmware Updates and Model Upgrades

A local NovAtel dealer can provide all the information needed to upgrade or update a receiver. Refer to novatel.com/contactus/sales-offices for contact information or contact sales.nov.ap@hexagon.com or support.novatel@hexagon.com directly.

9.1.1 Firmware Updates

Firmware updates are firmware releases that include fixes and enhancements to the receiver functionality. Firmware updates are released on the NovAtel web site as they become available. Firmware upgrades can be performed using the WinLoad utility, SoftLoad commands, Setup & Monitor (Web), NovAtel Application Suite or with a custom loader application. Contact NovAtel Customer Support (support.novatel@hexagon.com) for details on custom loader requirements.

9.1.2 Model Upgrades

Model upgrades enable purchased receiver features.

Contact a local NovAtel dealer to assist in selecting the upgrade options that best suit your GNSS needs at novatel.com/contactus/dealer-network. Contact NovAtel Customer Support novatel.com/support or novatel.com/contactus/sales-offices to request a temporary upgrade authorization code for trial purposes.

Model upgrades can be applied to the receiver with an authorization code and the **AUTH** command without returning the receiver to the dealer.

9.2 Authorization Code

An authorization code, commonly known as an auth-code, is required to change the software model on a receiver. Auth-codes are obtained by contacting novatel.com/support. Upon contact, NovAtel Customer Support requires:

- the receiver model number
- the receiver serial number
- the receiver firmware version

Enter the **LOG VERSION** command to determine the receiver model, serial number and firmware version.

Example:

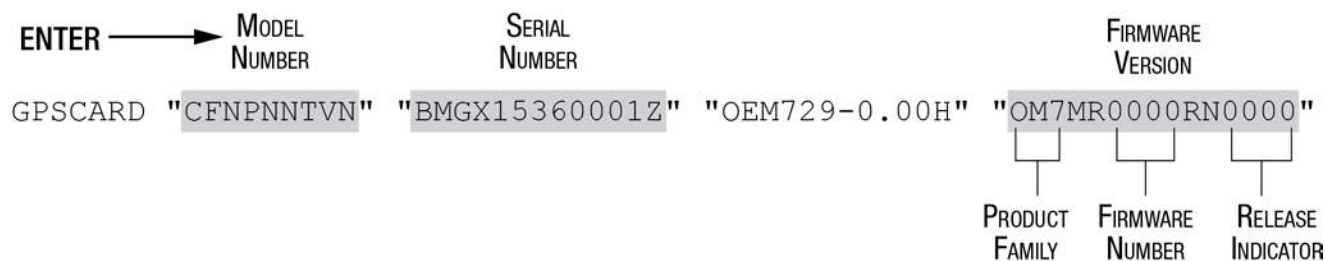

After determining the appropriate model and firmware version, the authorization code (auth-code) is issued. The auth-code is required to unlock the features on the new model type.

To upgrade to a new model with the same firmware version, use the **AUTH** command with the issued auth-code, as outlined in *Upgrading Using an Auth-Code* on page 132.

To upgrade to a new model with a new firmware version, the new firmware needs to be loaded into the OEM7 receiver. For instructions, refer to *Updating or Upgrading Using the WinLoad Utility* on the next page, *Updating the Firmware Using NovAtel Application Suite* on page 118, *Updating the Firmware Using Setup & Monitor (Web)* on page 119 or *Updating Using SoftLoad Commands* on page 119.

Auth-codes work with any signed firmware image. Therefore, if a receiver has an auth-code for the old version of firmware, that same auth-code will work for the new version of firmware, provided both images are digitally signed by NovAtel.

Signed firmware images are distributed in *.shex files. The new download package includes a signed firmware file type that uses an extension designated as ".shex" (example OM7MR0200RN0000.shex), as well as the latest WinLoad utility and What's New file containing firmware update change details.

Temporary auth-codes may be provided by NovAtel for evaluation purposes. Once the trial period has expired, the functionality provided by the auth-code is removed. The expiration date for temporary auth-codes is in the form YYMMDD, where YY = year, MM = month and DD =day. The date is the last day that the auth-code is valid and expires at the end of day, UTC time.

Once the trial period has expired, a new auth-code will need to be obtained from NovAtel Customer Support (support.novatel@hexagon.com).

Firmware images may also have auth-codes embedded within them. The models provided by such firmware images will be valid only on receivers with certain PSNs and Hardware Versions.

9.3 Downloading Firmware Files

To proceed with an update or possibly an upgrade, obtain the latest version of firmware by downloading the firmware file for your product from novatel.com/support/support-materials/firmware-download.



If the receiver is an H-model, do not use the firmware available from the web site. Contact *Customer Support* on page 17 to obtain the correct firmware.

9.3.1 Format of Firmware Files

All of the firmware available on the downloads website are packaged in .zip files with the following name:

- 7XXXX-Firmware.zip for firmware to be installed on OEM7 receivers

For convenience, unzip the update file to a GNSS sub-directory (for example, C:\GNSS\LOADER). If the firmware update file is password protected, NovAtel Customer Support provides the required password.

The zip archive includes the following files:

winload.exe	WinLoad utility program
howto.txt	Instructions on how to use the WinLoad utility
whatsnew.rtf	Information on the changes made in the firmware since the last revision
x..x.shex	Firmware version upgrade file, where x..x defines the product name and release (e.g., OM7MR0200RN0000.shex)
NovAtel Software License Agreement.rtf	License agreement for the firmware



NovAtel has an online video tutorial that explains firmware updating at: novatel.com/support/support-materials/novatel-video.

9.4 Updating or Upgrading Using the WinLoad Utility

WinLoad is a utility used to update or upgrade a receiver. To use WinLoad, the receiver must be connected to the computer running WinLoad using a serial port (COM port) connection.

If opening WinLoad for the first time, ensure the file and communications settings are correct.

9.4.1 Open a File to Download

Select File | File Open. Navigate to the file to open (*Figure 39: WinLoad's Open Window* below).

Figure 39: WinLoad's Open Window

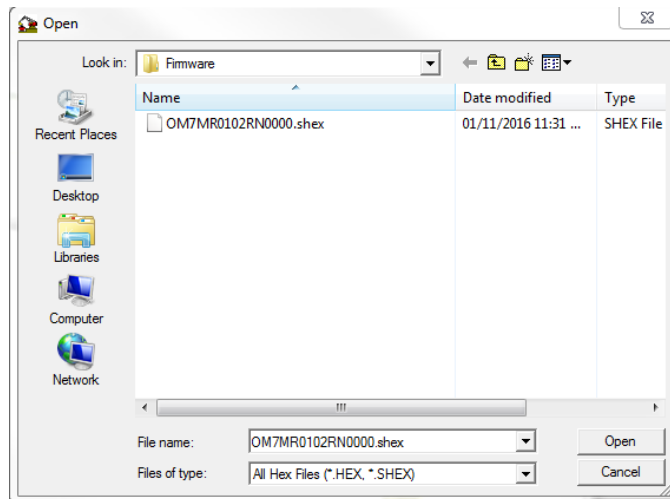

When a file is selected, the *filename* appears in the main WinLoad display area and in the title bar (*Figure 40: Open File in WinLoad* on the next page).

Figure 40: Open File in WinLoad

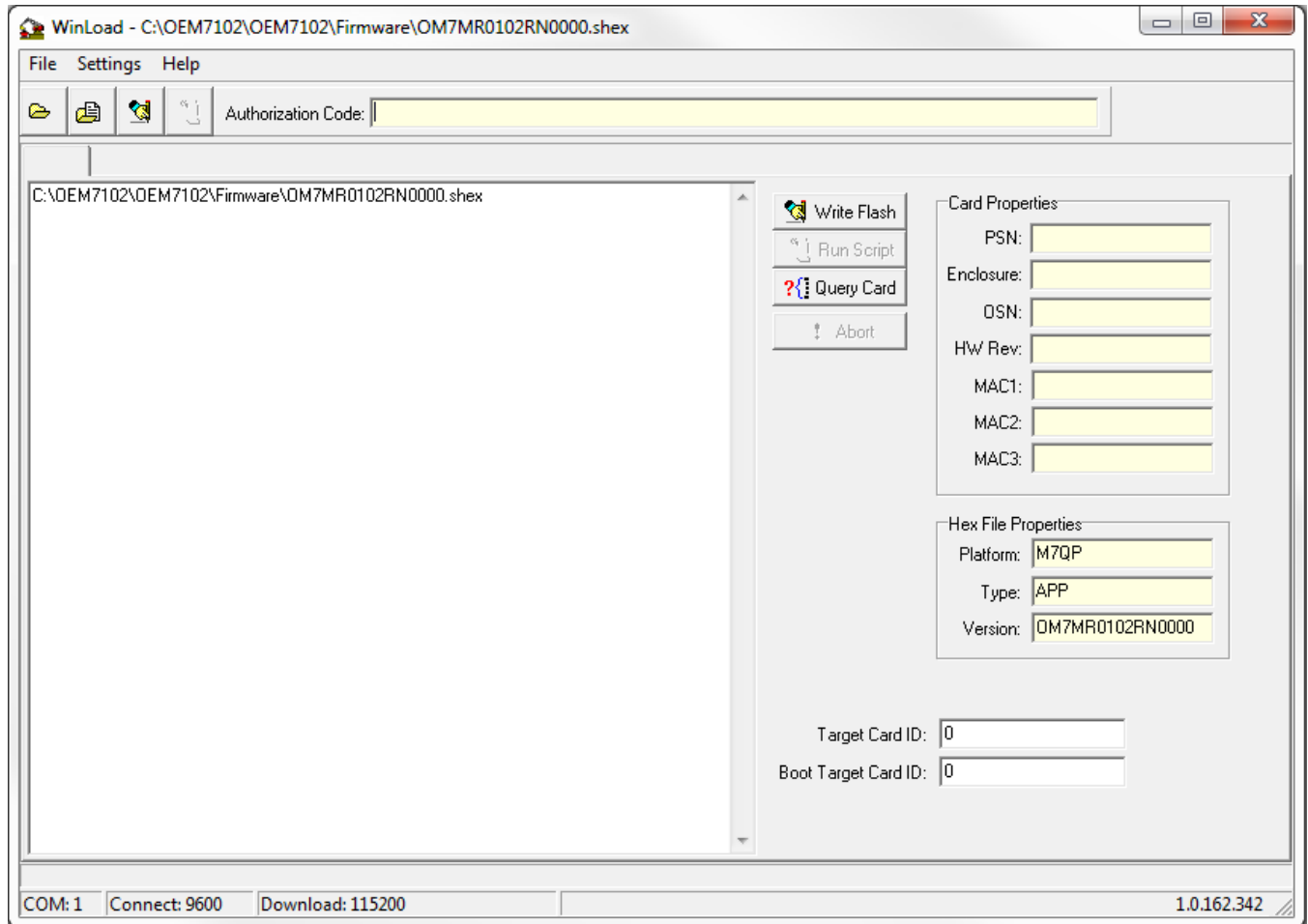

9.4.2 Communications Settings

To set the communications port and baud rate, select Settings | COM Settings. Choose the computer port to use from the Com Port drop down list and the baud rate from the Download Baudrate drop down list. Set the baud rate as high as possible (the default of 115200 is preferred if a higher baud rate is not available).

Figure 41: COM Port Setup

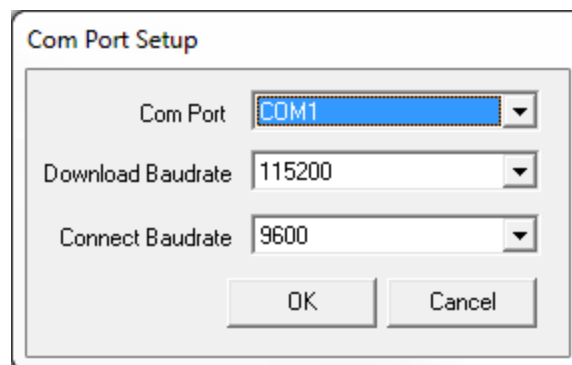

9.4.3 Downloading Firmware

1. Select the file to download according to *Open a File to Download* on page 116.
2. Ensure the file path and name are displayed in main display area (see *Figure 40: Open File in WinLoad* on the previous page).
3. Click **Write Flash** to download the firmware.
4. When *Searching for card* appears in the main display, power cycle the receiver.
5. If the Authorization Code window appears, enter the auth-code and click **OK**. See *Authorization Code* on page 114 for further information about the Authorization Code.
6. The receiver finishes the download and then resets. The process is complete when *Done* appears in the main display area.
7. Close WinLoad.



If loading a firmware that is currently installed on a receiver (i.e. reloading the same version of firmware on a receiver), ensure that *Optimized Loading* option is unchecked in WinLoad under *Settings | Options | Optimized Loading*.

9.5 Updating the Firmware Using NovAtel Application Suite

To use NovAtel Application Suite to update the receiver firmware, the receiver must be connected to the computer running NovAtel Application Suite using a serial (COM) port, USB port or Ethernet port.

To update the firmware on the receiver:

1. Obtain the new firmware file.

See *Downloading Firmware Files* on page 115 for information about obtaining the latest version of receiver firmware.



Copy the firmware file to the computer's local drive before uploading.

2. Connect a computer to the receiver using a serial (COM) cable, USB cable or Ethernet connection.
3. Start NovAtel Application Suite on the computer.
4. Use NovAtel Application Suite to connect to the receiver.

For information about using NovAtel Application Suite, refer to docs.novatel.com/Tools.

5. On the *Status and Configuration* window, click the **Device** menu and select **Update**.

The *Update* window appears.

6. Click the **Browse** button.
7. Navigate to the directory that contains the new firmware file and select the file.
8. Click the **Open** button.

The Update window appears with the name of the selected file in the Select File field.

9. Click the **Apply** button.

After the new software is loaded, the receiver will restart.

9.6 Updating the Firmware Using Setup & Monitor (Web)

To use NovAtel Setup & Monitor (Web) to update the receiver firmware, the receiver must be connected to the receiver using an Ethernet connection.

To update the firmware on the receiver:

1. Obtain the new firmware file.

See *Downloading Firmware Files* on page 115 for information about obtaining the latest version of receiver firmware.



Copy the firmware file to the device's local drive before uploading.

2. Connect the receiver to a computer using an Ethernet connection.
3. Open a web browser and enter the IP address assigned to the receiver.
The Setup & Monitor (Web) Home page appears.
4. Click the Menu icon and select **Update**.
5. Click the **Select File** button
6. Navigate to the folder in which the new software to load is stored and select the software file.
7. Click the **Apply** button.

After the new software is loaded, the receiver will restart.

9.7 Updating Using SoftLoad Commands

Firmware can be updated on a running receiver using a process called SoftLoad. Any available communication ports on the receiver (COM, USB, ICOM) can be used. The SoftLoad process is made up of a set of commands and logs that are used to send new firmware data to a receiver and check the progress of the update.

Use SoftLoad if automated loading is desired or if the receiver does not have access to tools such as NovAtel Application Suite, Setup & Monitor (Web), WinLoad (serial connection only), NovAtel Connect or WebUI to load firmware.

The receiver stops tracking GNSS satellites during the SoftLoad process. Do not attempt to SoftLoad when GNSS satellite tracking on the unit is required. If the unit is connected to the NovAtel Connect utility, only the Console and ASCII Message windows may remain open in the Connect Utility.

9.7.1 Implementing SoftLoad

To implement the SoftLoad process, you can either:

- Use SoftLoad Customer Support utilities:

You can use NovAtel developed utilities to upgrade firmware. This method is easier to implement than self-implementing Softload. This method is preferable for Linux users, who cannot use other NovAtel utilities easily. For more information suitability and implementation, refer to *Use SoftLoad Customer Support utilities* on the next page.

- Self-Implement the SoftLoad process:

You can develop the process on your own, including processing the S-Records, converting them to NovAtel format commands, and Sending Firmware Data. This method is suitable for users with deeply

embedded receivers and is more difficult to implement and integrate. For more information on suitability and implementation, refer to *Self-Implement the SoftLoad process* on page 125.

9.7.2 Use SoftLoad Customer Support utilities

This method is appropriate for customers that want to upgrade firmware without the complexity of self-implementing the SoftLoad process, but cannot use NovAtel Application Suite, Setup & Monitor (Web), WinLoad, NovAtel Connect or WebUI to load firmware. This method requires at a minimum:

- The desired firmware build as an .shex file
- The utility – srec2softload_dev_20160603.exe
- The receiver must be able to connect to a terminal like RealTerm

For Linux users, this method may be preferred as NovAtel does not offer production versions of Linux NovAtel Connect and Linux WinLoad. Also, some NovAtel products may not have WebUI compatibility or WebUI connection may not be easily viable for some customers.

For Linux users in these situations, only a terminal program such as RealTerm is needed for the firmware upgrade (along with preparing the .shex file).



There is Linux NovAtel Application Suite available which can be used for firmware upgrading (without using SoftLoad).

Process for using Customer Support utilities

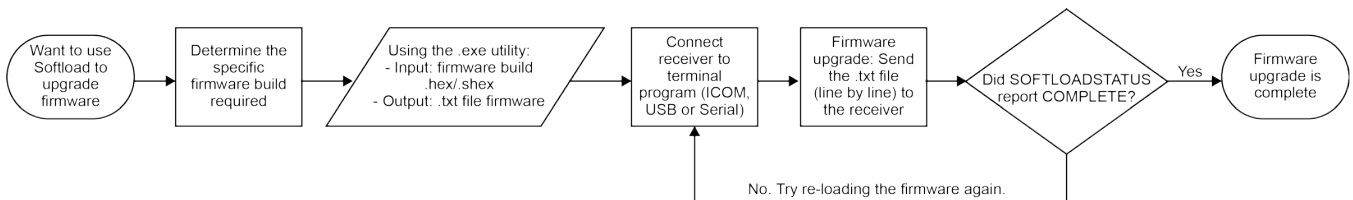

Using the srec2softload utility

1. Contact Customer Support at novatel.com/support and ask about the **srec2softload** utility.



At this step the Customer Support representative may assist in directly preparing the txt batch file for you. In this case, continue at *Sending Firmware Data* on the next page.

2. In a new folder, load the srec2softload_dev_20160603.exe utility and the desired shex/hex firmware file
3. Create a blank text file (can name it as desired, eg "softload_OM7MR0703RN0000.txt"). This text file will be the output from the utility where the batch script will be converted and placed.
4. In that folder, open up a Powershell window and enter:

```
<softload utility name> <input shex/hex file> <output blank text file>
```

For example: `.\srec2softload_dev_20160603 .\OM7MR0703RN0000.shex .\softload_OM7MR0703RN0000.txt`

5. Press **Enter** and the output text file will be populated with the batch file. A confirmation message/response will appear.

Sending Firmware Data

It can take 30 minutes to 1 hour to complete sending the entire firmware to the receiver. RealTerm is preferred, but other terminal programs may be used (at user's discretion).

1. Download RealTerm from: sourceforge.net/projects/realterm/.
2. Open RealTerm, go to the Port tab.
3. Choose the COM port to be used (if using USB or Serial) along with the appropriate baud rate. If using Ethernet, type the IP address right where the Port dropdown menu is. Baud rate is not required to be specified if using Ethernet.



If using ICOM (Ethernet), ensure the Winsock option is set to Raw, otherwise the binary part of firmware will be encoded and produce CRC errors. This is not necessary if connecting via serial or USB.



If using ICOM (Ethernet), a connection will be verified by the [ICOM1] string showing up at the top.



If using serial or USB, screen will appear empty.

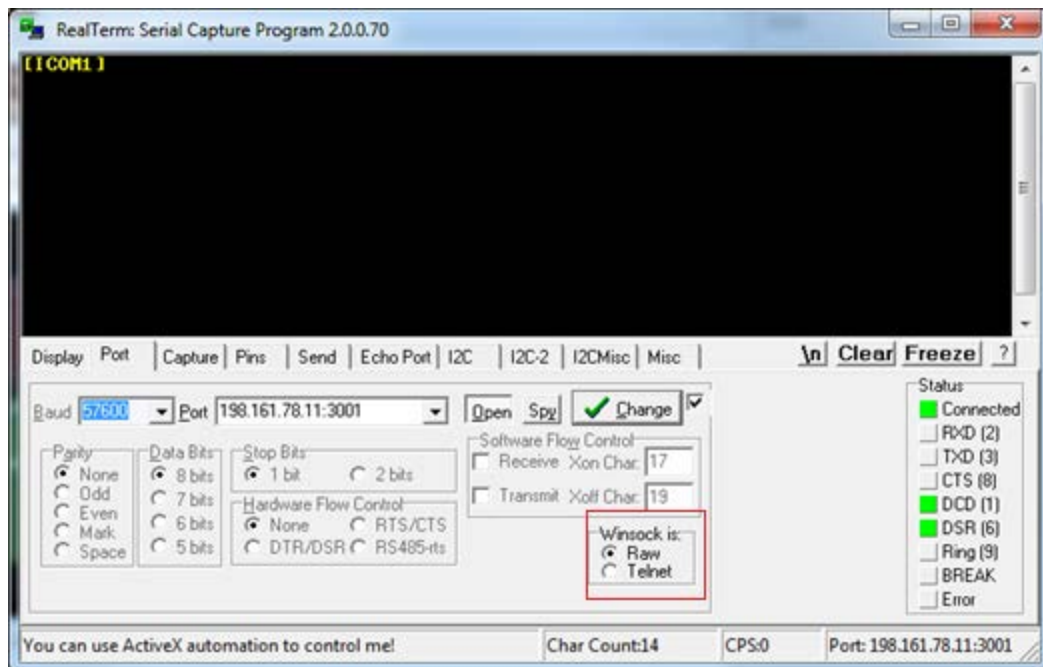

4. Go to the **Send** tab. Click on the ellipsis button to the right of the **Dump File to Port** drop down menu.

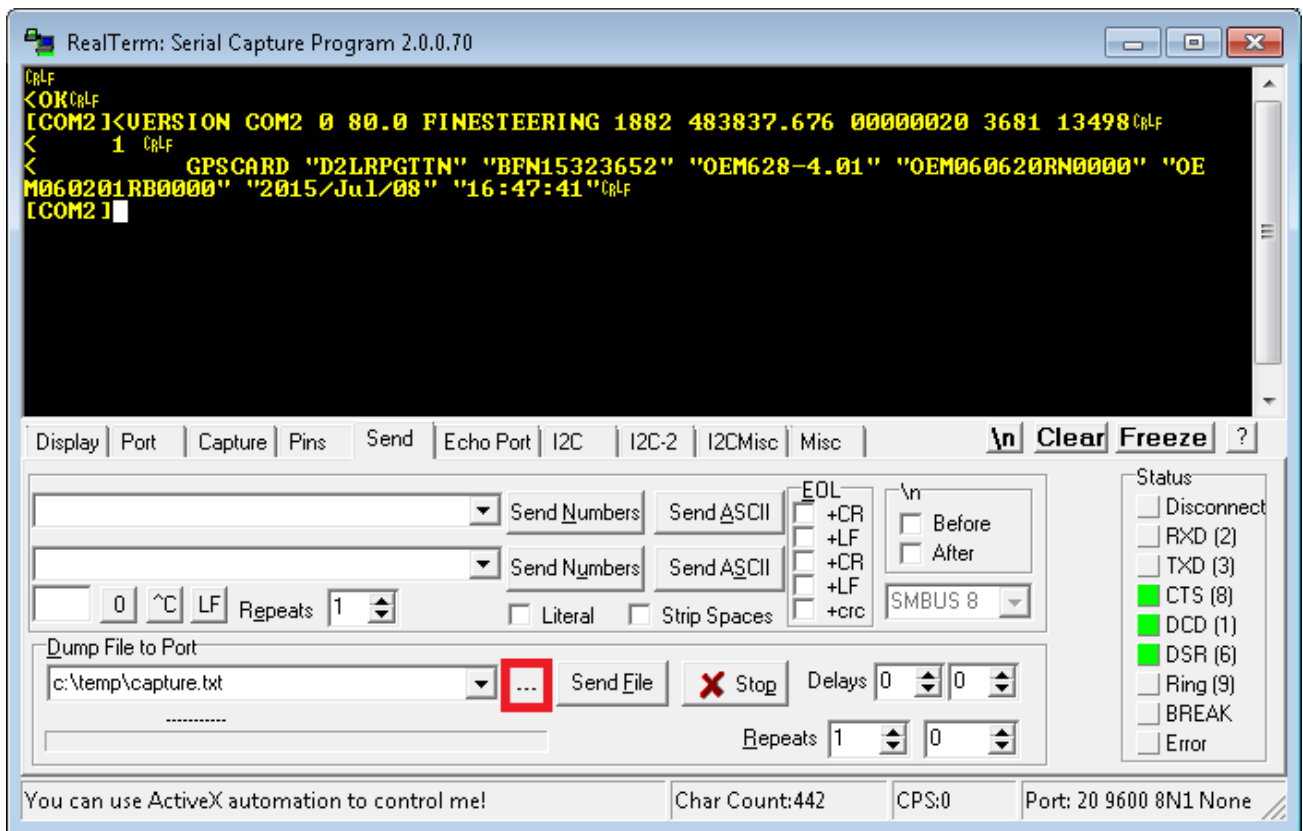

If connecting to receiver via serial or USB, ensure a delay of at least 20 msec is specified between each line. This is NOT necessary for ICOM connections; it will just cause the firmware to take longer to load. The option can be found in the *Send* tab of RealTerm.

Delays 0 20

5. Select the batch file containing the ASCII and binary SOFTLOAD records and click on **Send File**.

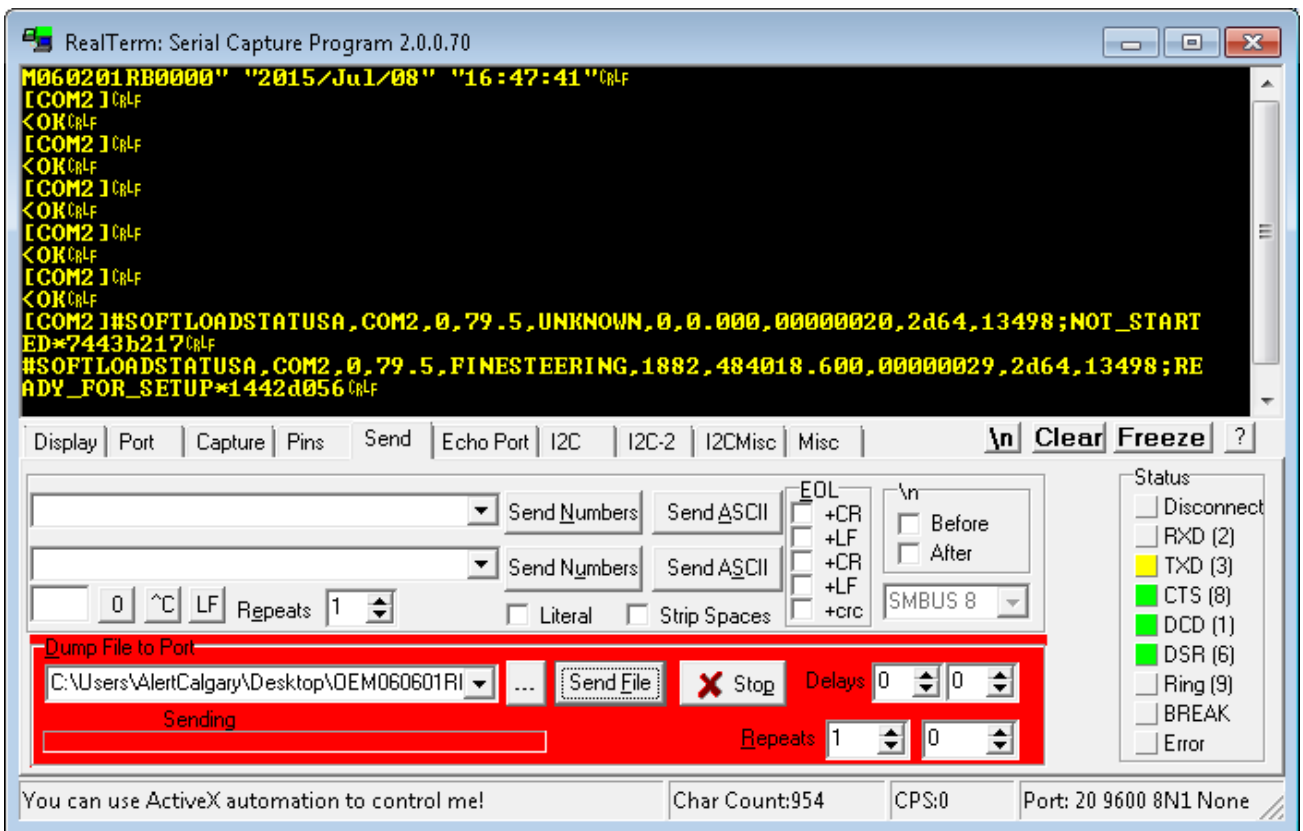

6. Watch the progress bar on the bottom as well as for the **OK** responses.

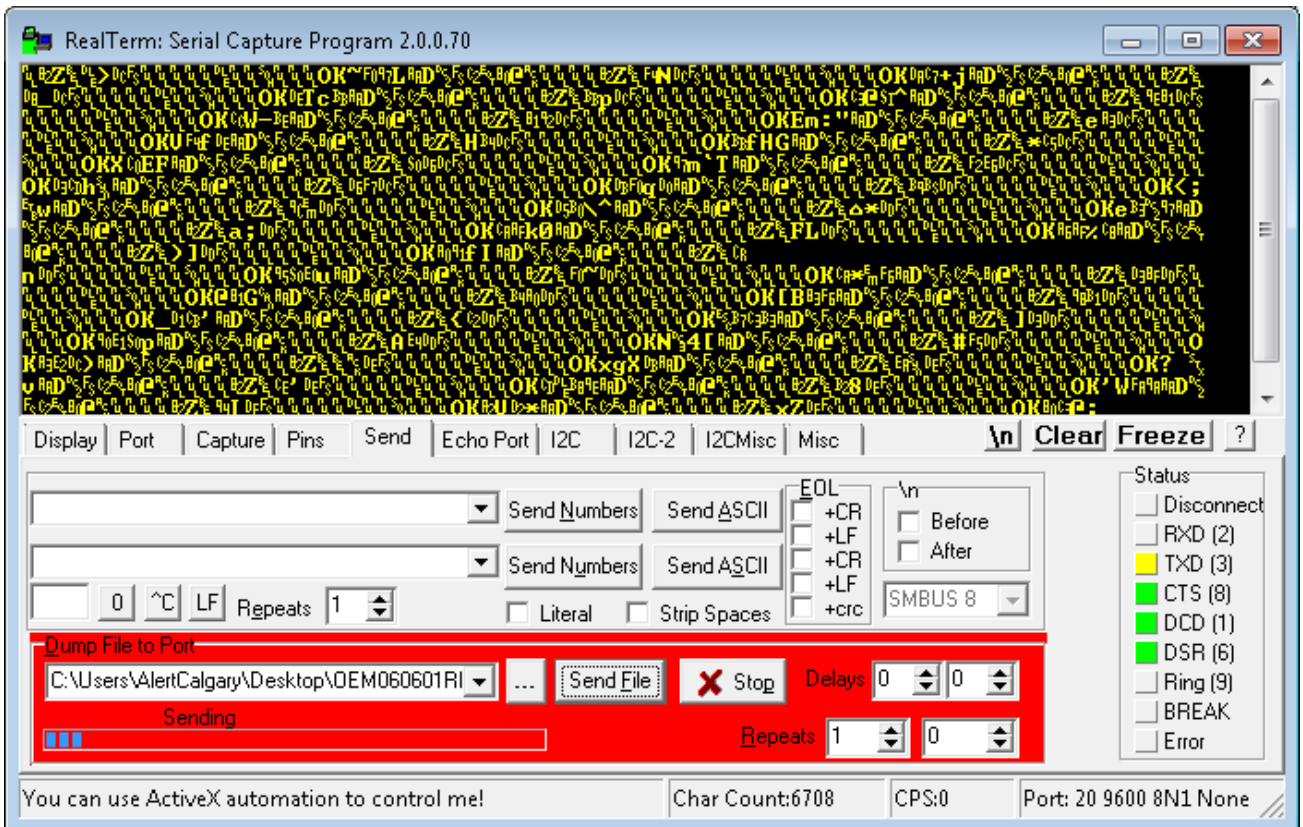

- RealTerm will indicate when the entire file has been sent. Note the output at the end indicates SOFTLOAD completed without any issues.

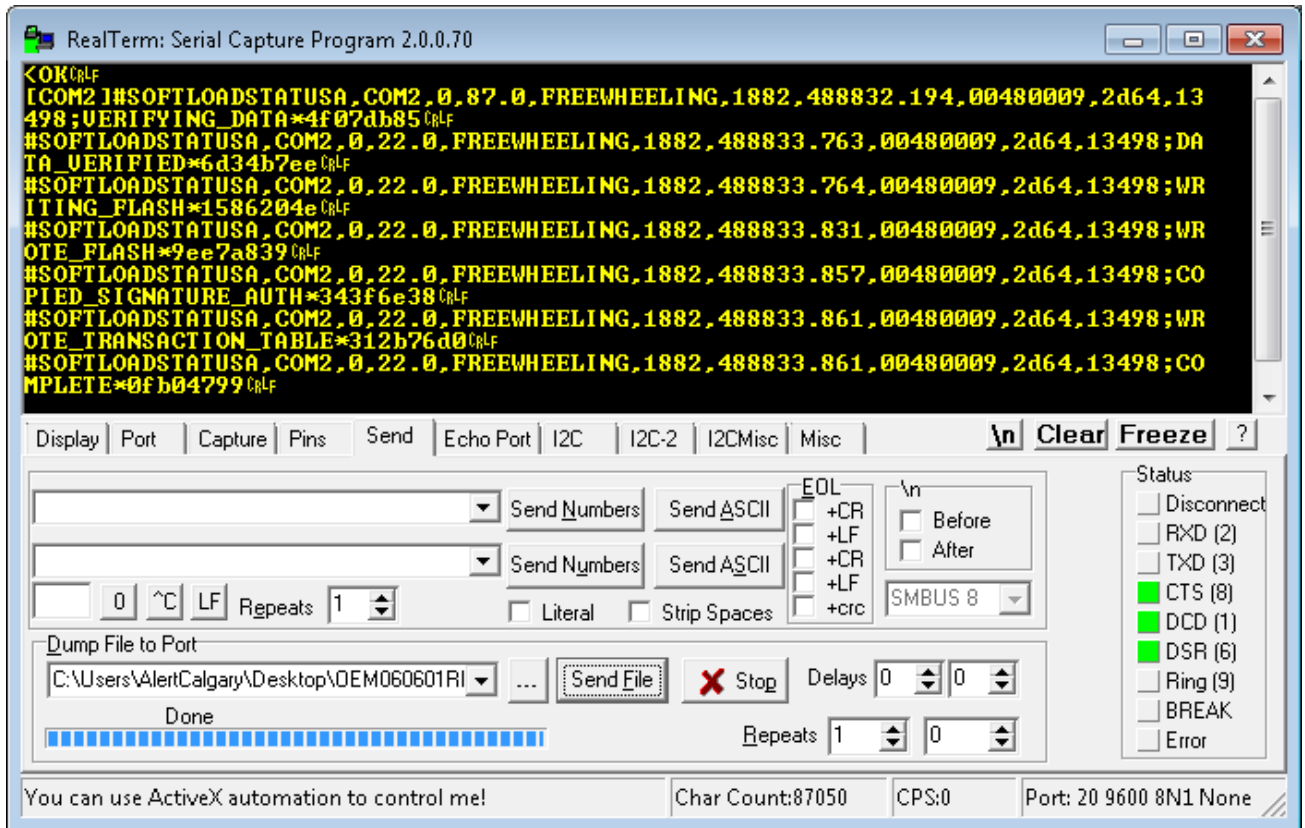

- Once SOFTLOADSTATUS has confirmed the process is COMPLETE, send the **RESET** command.
- Once the receiver has been reset, send the **LOG VERSION** command to confirm the desired firmware version has been installed.

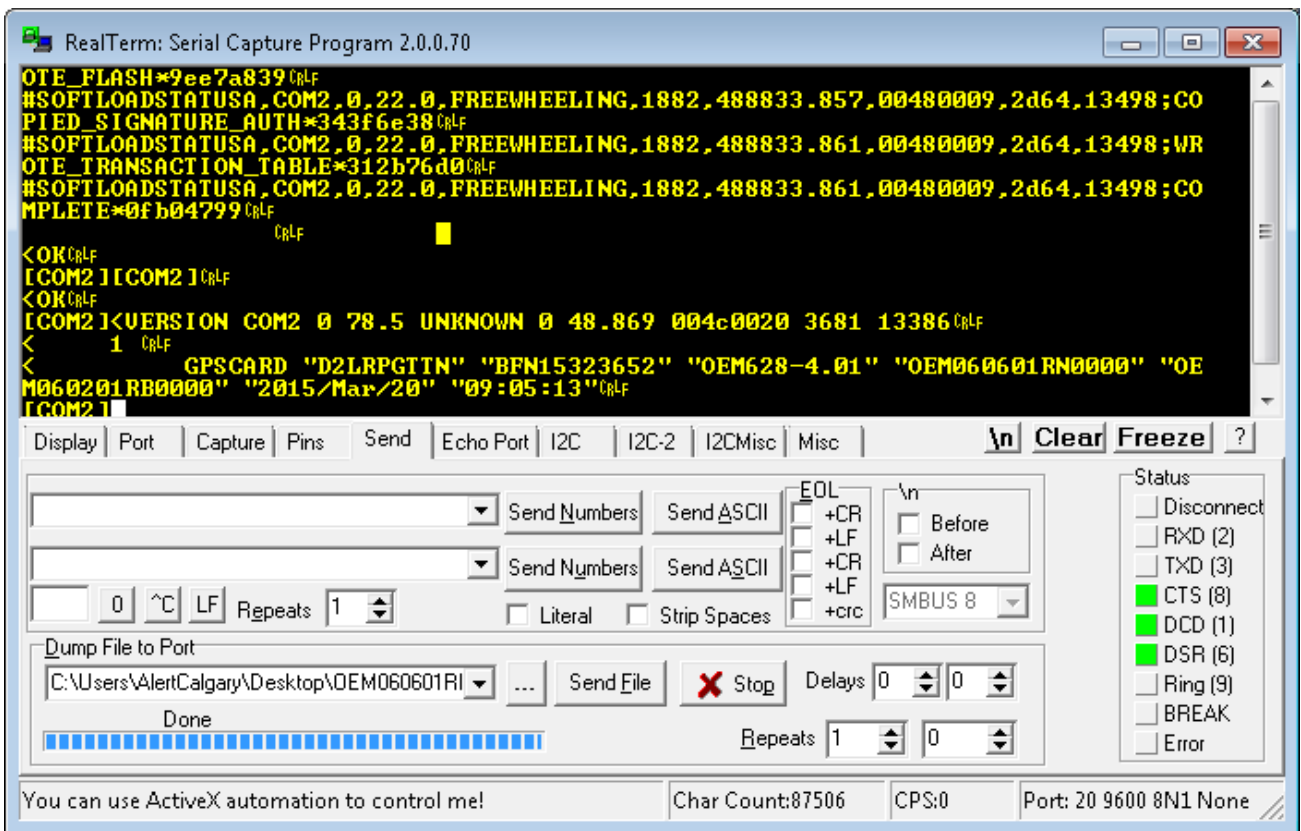

SoftLoad Errors

It is possible for errors to occur during the SoftLoad update. All command responses should be checked to verify all issued commands were accepted. The SoftLoad status should also be monitored in the **SOFTLOADSTATUS** log. Any status enum value greater than the ERROR status indicates an error has occurred during the SoftLoad update. In the event of an error, the SoftLoad update should be restarted by issuing a **SOFTLOADRESET** command or normal operation can be restored by resetting the receiver.

In rare cases after a SoftLoad error, the boot code may not be able to determine which is the latest firmware to be executed. To protect against this, SoftLoad does not erase the previous valid firmware image from flash on the receiver. In such cases, the boot code will execute the old image and raise the "Safe Mode" error (see **RXSTATUS** log). If that error is detected, simply restart the SoftLoad process to reload the new firmware image and the error will be resolved.

9.7.3 Self-Implement the SoftLoad process

This method is appropriate for users with deeply embedded systems and that want to customize the firmware updating process to their application. C++ source code is available to provide example code of processing S-Records and converting them to NovAtel format commands.

Contact Customer Support at novatel.com/support and ask about the srec2softload utility. The C++ source code can then be customized to your application.

SoftLoad Commands and Logs

Refer to the [OEM7 Commands and Logs Reference Manual](#) for detailed log and command information.

Command	Description
SOFTLOADRESET	Initiate a new SoftLoad process
SOFTLOADSREC	Send an S-Record to the receiver for the SoftLoad process
SOFTLOADDATA	Send firmware image data to the receiver for the SoftLoad process
SOFTLOADCOMMIT	Complete the SoftLoad process
SOFTLOADSETUP	Send configuration information to the receiver for the SoftLoad process. This command is not required when working with a *.shex file
SOFTLOADFILE	Load a firmware image that has been loaded onto the internal storage of the receiver.

Log	Description
SOFTLOADSTATUS	Provides status updates for the ongoing SoftLoad process

Each command and log can be used in abbreviated ASCII, ASCII or binary format, with the exception of SOFTLOADDATA, which should only be used in binary format.

File Types

Firmware data is stored in *.shex files as ASCII data in the form of S-Records, based on the Motorola S-Record format. The *.shex file includes a digital signature for the firmware.

Working With S-Records

Each S-Record has a header indicating the type of information contained in the record.

Records beginning with S0, S5 and S7 contain metadata about the firmware image, such as version information and which card types are supported by the firmware image.

Example S0 Record

```
S0~V~OM7MR0400RN0000
```

Example S5 Records

```
S50000
```

```
S503D9FE25
```

```
S5033158D5A
```

Example S7 Records

```
S70000
```

```
S70500000000FA
```

Records beginning with S3 contain the actual firmware image data. Aside from the header, each pair of characters forms the ASCII representation of a binary byte. The format is as follows:

S3	LL	AAAAAAA	DDDDDDDD...DDDDDDDD	CC
		Check Sum		
Little Endian Data. These bytes are copied into the "data" field of the SOFTLOADDATA command				
4 - Byte Address. Set this as the value of "offset" in the SOFTLOADDATA command				
Length. This is the hexadecimal number of character pairs to follow in the record. This value minus 4 bytes for the address and 1 byte for the check sum is copied into the "data length" field of the SOFTLOADDATA command				
Header				

Sending Firmware Data

The **SOFTLOADSREC** and **SOFTLOADDATA** commands can be used to send firmware data from *.shex files to the receiver.

S0, S5 and S7 S-Records should be sent directly to the receiver using the **SOFTLOADSREC** command, by enclosing the S-Record in quotation marks and issuing the command to the receiver, as follows:

```
SOFTLOADSREC "<S-RECORD>"
```

S3 records can be sent individually to the receiver using the **SOFTLOADSREC** command. Alternatively, the data from an S3 record can be parsed and packaged together with data from other S3 records into a binary **SOFTLOADDATA** command. Packaging data parsed from multiple S3 records into a binary **SOFTLOADDATA** command can result in improved firmware update times as each S3 record contains only a small number of bytes of firmware data. A single **SOFTLOADDATA** command can package up to 4096 bytes of firmware data from multiple S3 records, whereas a single **SOFTLOADSREC** command contains a maximum of 28 bytes of firmware data from a single S3 record.

Multiple S3 records can be packaged into a single **SOFTLOADDATA** command as long as the data from one S3 record follows immediately after the previous record. That is, the address from the current S3 record must equal the address from the previous S3 record plus the data length of the previous S3 record. If the data is not consecutive then the **SOFTLOADDATA** command can be sent with the amount of data it has packaged up to that point. Subsequent data can be packaged in a new **SOFTLOADDATA** command. Within the **SOFTLOADDATA** command, the "offset" field remains the address of the first S3 record and the "data" and "data length" are updated to include the new data.

The *.shex file data may contain many gaps and jumps. For example, in many NovAtel *.shex files, data for address 0x000_00000 is stored near the very end of the file.

Example Packaging Multiple S3 Records In A SOFTLOADDATA Command

Start a new **SOFTLOADDATA** command

```
S32100407AD48FCA63034B80F5CE0C36507DE3D8DCC0C6C0C00515D74BCACF2F2949E1
```

Address: 0x00407AD4 Num Data Bytes: 0x21 – 0x01 – 0x04 = 0x1C

```
S32100407AF04CCA4985F0F7B081E41D9B7D806C26989AE2D4E4CCBCB47C10FBFD3E43
```

Previous Address + Previous Num Bytes = 0x00407AD4 + 0x1C = 0x00407AF0

Address: 0x00407AF0 Num Data Bytes: 0x1C

Add data to existing **SOFTLOADDATA** command

```
S30D00407B0CDE0400A6374D5BFFC5
```

Previous Address + Previous Num Bytes = 0x00407AF0 + 0x1C = 0x00407B0C

Address: 0x00407B0C Num Data Bytes: 0x0D – 0x01 – 0x04 = 0x08

Add data to existing **SOFTLOADDATA** command

```
S3210000000007F0A7F1F4060000147B4000F49217813C7BB00014493F005C00000009
```

Previous Address + Previous Num Bytes = 0x00407B0C + 0x08 = 0x00407B14

Address: 0x00000000 Num Data Bytes: 0x1C

Requires new **SOFTLOADDATA** command because address does not match previous address + previous number of data bytes

Send existing **SOFTLOADDATA** command, and start a new **SOFTLOADDATA** command

```
S3210000001C80040000E001000030000000082B0100D8060000E4060000C806000063
```

Address: 0x0000001C Num Data Bytes: 0x1C

Previous Address + Previous Num Bytes = 0x00000000 + 0x1C = 0x0000001C

Add data to existing **SOFTLOADDATA** command

The **SOFTLOADDATA** command must be sent as a NovAtel binary format command.

SoftLoad Update Method

This section describes the sequence of commands that are issued to the receiver when updating using a *.shex file.



The response for each command must be processed before sending the next command so as to determine if the command was accepted or rejected, and to wait for the receiver to complete the operation. Responses to SoftLoad commands are guaranteed to be output from the receiver within a specific time, which varies by command. Refer to specific SoftLoad command for more information on responses and the timeout values for SoftLoad commands.

1. Open a connection to any port on the receiver (COM, USB or ICOM) with the input and output INTERFACEMODE set to NOVATEL.
2. Request the SOFTLOADSTATUS log using the following command:

```
LOG SOFTLOADSTATUSA ONCHANGED
```
3. Initialize SoftLoad with a **SOFTLOADRESET** command. This command stops all tracking on the receiver to ensure sufficient memory is available for the loading process. An RXSTATUSEVENTA log reports a SoftLoad In Progress status.
4. Open the *.shex firmware file.
5. Read each line of the *.shex firmware file.
 - a. Send S0, S5 and S7 S-Records directly to the receiver using the **SOFTLOADSREC** command. The S-Record must be enclosed in quotation marks:

```
SOFTLOADSREC "<S-RECORD>"
```

 Data within S0 records can also be sent to the receiver by converting them to **SOFTLOADSETUP** commands. Refer to the **SOFTLOADSETUP** command in the [OEM7 Commands and Logs Reference Manual](#) for details on how to convert from S0 S-Records to **SOFTLOADSETUP** commands.
 - b. S3 S-Records should be parsed and packaged into a **SOFTLOADDATA** command.
6. Send the **SOFTLOADCOMMIT** command after all data from the *.shex file has been transferred to the receiver. The SOFTLOADSTATUS log reports the status of the loading process. Wait for a SOFTLOADSTATUS log to indicate the status is COMPLETE. The COMPLETE status or an error is

guaranteed to be output from the receiver within 300 seconds from the time the **SOFTLOADCOMMIT** command was received by the receiver.

7. Send the auth code for the newly downloaded image using the **AUTH** command. This is only required if there is not already a signature auth code on the receiver as signature auth codes are maintained through a SoftLoad update. See *Authorization Code* on page 114 for details on Auth Codes.

```
AUTH ADD_DOWNLOAD <AUTH CODE>
```

8. Reset the receiver using any of the following methods:
 - Enter the **RESET** command
 - Enter the **FRESET** command
 - Power-cycle the receiver

Once the receiver resets, the new version of firmware is active.

The SoftLoad process can be safely canceled at any time using the **SOFTLOADRESET** command or by otherwise resetting the receiver. Once the COMPLETE status is reported by SOFTLOADSTATUS, the new firmware image will be run after the receiver is reset.

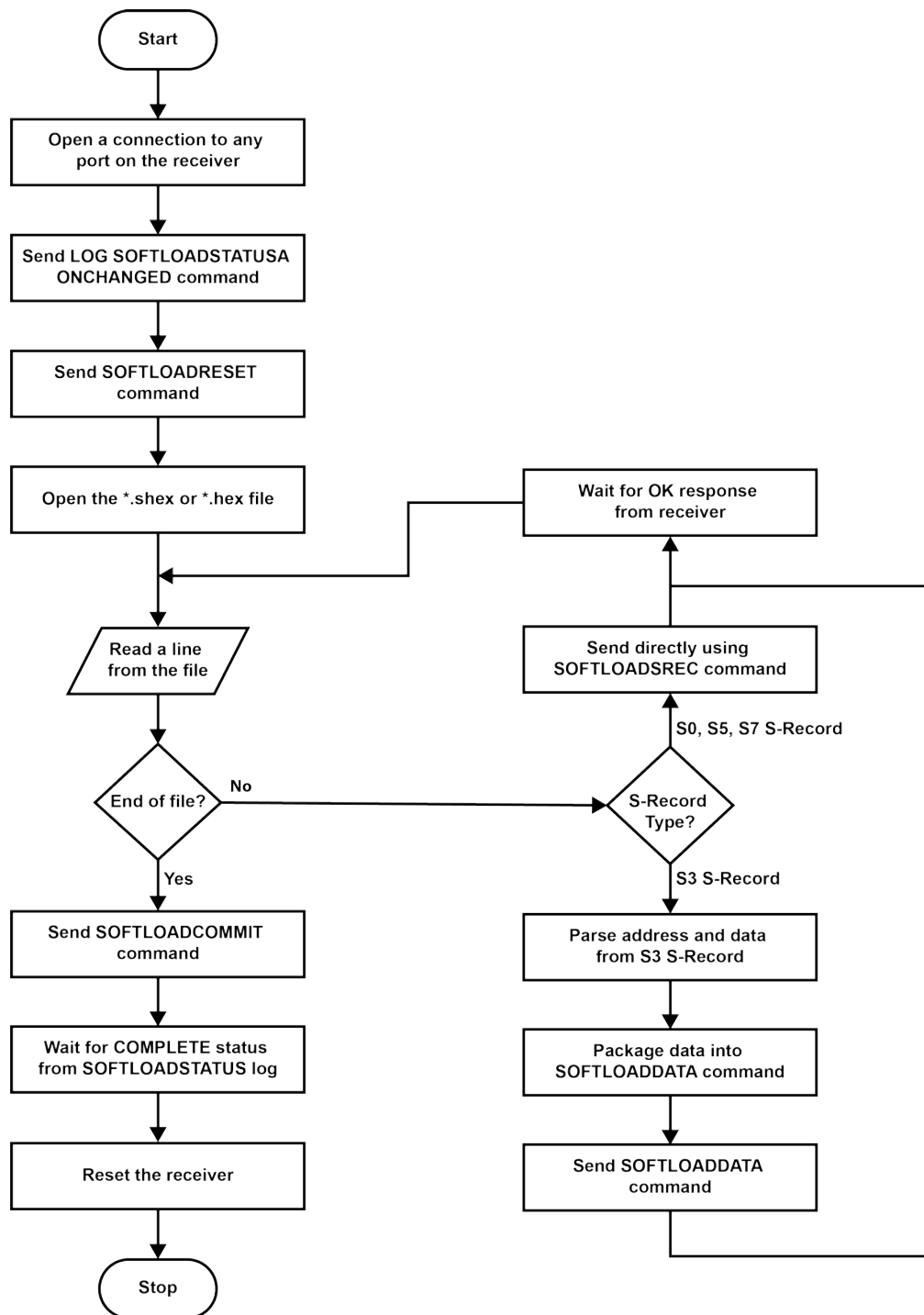

SoftLoad Errors

It is possible for errors to occur during the SoftLoad update. All command responses should be checked to verify all issued commands were accepted. The SoftLoad status should also be monitored in the **SOFTLOADSTATUS** log. Any status enum value greater than the ERROR status indicates an error has occurred during the SoftLoad update. In the event of an error, the SoftLoad update should be restarted by issuing a **SOFTLOADRESET** command or normal operation can be restored by resetting the receiver.

In rare cases after a SoftLoad error, the boot code may not be able to determine which is the latest firmware to be executed. To protect against this, SoftLoad does not erase the previous valid firmware image from flash on

the receiver. In such cases, the boot code will execute the old image and raise the "Safe Mode" error (see **RXSTATUS** log). If that error is detected, simply restart the SoftLoad process to reload the new firmware image and the error will be resolved.

9.8 Update Setup & Monitor (Web)

Setup & Monitor (Web) is hosted on the OEM7 receiver. To update Setup & Monitor (Web), a new Setup & Monitor (Web) software package is loaded onto the receiver.



This section applies only to receivers that support Setup & Monitor (Web), such as the PwrPak7, SMART7 or Ethernet capable OEM7 receivers.

9.8.1 Update Setup & Monitor (Web) Content Using NovAtel Application Suite

To update Setup & Monitor (Web) on the receiver:

1. Obtain the new Setup & Monitor (Web) file.

The latest version of Setup & Monitor (Web) content is available on the NovAtel website (novatel.com/support).



Copy the Setup & Monitor (Web) file to the device's local drive before uploading.

2. Connect a computer to the receiver using a serial (COM) cable, USB cable or Ethernet connection.
3. Start NovAtel Application Suite on the computer.
4. Use NovAtel Application Suite to connect to the receiver.

For information about using NovAtel Application Suite, refer to docs.novatel.com/Tools.

5. On the *Status and Configuration* window, click the **Device** menu and select **Update**.

The *Update* window appears.

6. Click the **Browse** button.
7. Navigate to the directory that contains the new Setup & Monitor (Web) file and select the file.
8. Click the **Open** button.

The Update window appears with the name of the selected file in the Select File field.

9. Click the **Apply** button.

After the new software is loaded, the receiver will restart.

9.8.2 Update Setup & Monitor (Web) Content Using Setup & Monitor (Web)

To update Setup & Monitor (Web) on the receiver:

1. Obtain the new Setup & Monitor (Web) file.

The latest version of Setup & Monitor (Web) content is available on the NovAtel website (novatel.com/support).



Copy the Setup & Monitor (Web) file to the device's local drive before uploading.

2. Use a Wi-Fi capable device (such as a laptop, tablet or smart phone) to connect to the receiver's Wi-Fi access point. The SSID and password for the receiver Wi-Fi are on a label on the receiver.
Alternately, connect the receiver to a computer using an Ethernet connection.
3. Open a web browser and enter **192.168.19.1** in the address (URL) bar of the browser.
If using an Ethernet connection, enter the IP address assigned to the receiver.
The Setup & Monitor (Web) Home page appears.
4. Click the Menu icon and select **Update**.
5. Click the **Select File** button
6. Navigate to the folder in which the new Setup & Monitor (Web) software to load is stored and select the software file.
7. Click the **Apply** button.
After the new software is loaded, the receiver will restart.

9.9 Upgrading Using an Auth-Code

An authorization code (auth-code) enables (unlocks) model features.

An auth-code can be entered using NovAtel Application Suite, NovAtel Web UI or the command line interface.

9.9.1 Entering an Auth-Code Using NovAtel Application Suite

1. Obtain the new auth-code from NovAtel Sales or your local NovAtel dealer.
2. Connect a computer to the receiver using a serial (COM) cable, USB cable or Ethernet connection.
3. Start NovAtel Application Suite on the computer.
4. Use NovAtel Application Suite to connect to the receiver.
For information about using NovAtel Application Suite, refer to docs.novatel.com/Tools.
5. Click the **Device** menu and select **Details**.
The **Details** window appears.
6. On the *Authorizations* tile, enter the new Auth Code in the **Apply New Auth Code** box.
7. Click the **Apply** button to save the changes to the receiver.
The receiver will restart when a new Auth Code is applied.

9.9.2 Entering an Auth-Code Using Setup & Monitor (Web)

1. Obtain the new auth-code from NovAtel Sales or your local NovAtel dealer.
2. Use a Wi-Fi capable device (such as a laptop, tablet or smart phone) to connect to the receiver's Wi-Fi access point. The SSID and password for the receiver Wi-Fi are on a label on the receiver.
3. Open a web browser and enter **192.168.19.1** in the address (URL) bar of the browser.
If using an Ethernet connection, enter the IP address assigned to the receiver.
The Setup & Monitor (Web) Home page appears.
4. Click the Menu icon and select **Details**.
The **Details** window appears.
5. Open the **Authorizations** tile.

6. Enter the new Auth Code in the **Apply New Auth Code** box.
7. Click the **Apply** button to save the changes to the receiver.

The receiver will restart when a new Auth Code is applied.

9.9.3 Entering an Auth-Code Using the Command Line

The **AUTH** command is used to enter an auth-code. The upgrade can be performed directly through the NovAtel Application Suite command line or from any other communications program.



Refer to *Format of Firmware Files* on page 115 for details on updating versus upgrading.

1. Power up the OEM7 receiver and establish communications.
2. Issue the **LOG VERSION** command to verify the current model, firmware version and serial number (refer to *Authorization Code* on page 114 for instructions on obtaining).
3. Issue the **AUTH** command, followed by the auth-code and model type (refer to *Authorization Code* on page 114 for details on obtaining any auth-code). The syntax is as follows:

```
auth <your auth-code here>
```

where **auth** is a command that enables model upgrades and auth-code is the upgrade authorization code, expressed as follows:

```
XXXXXX, XXXXXX, XXXXXX, XXXXXX, XXXXXX, MODEL, EXPDATE
```

where:

- Each X character is a case-insensitive ASCII character.
- The MODEL string is a maximum of 15 characters long and represents the model enabled by the auth-code.
- The EXPDATE string is the auth-code's expiry date, in YYMMDD format

Example:

```
auth 7WBMBK, 887CB6, K5J3FH, 5DF5P2, 42PW8G, D1SB0GTT0, 121211
```

When the **AUTH** command is executed, the OEM7 receiver reboots. Issuing the **LOG VERSION** command confirms the new upgrade model type and firmware version number.

If communicating using NovAtel Application Suite, the connection must be closed and reopened using the *Devices* window.

APPENDIX A OEM719 Technical Specifications

Table 13: OEM719 Physical Description

Size	46 mm x 71 mm x 11 mm
Weight	31 grams
NovAtel Part Number	Generic assembly OEM719 01019520

See the following sections for more information about the OEM719:

- *OEM719 Performance Specifications* on the next page
- *OEM719 Mechanical Specifications* on page 137
- *OEM719 Electrical and Environmental Specifications* on page 144
- *OEM719 Data Communication Specifications* on page 146
- *OEM719 Strobe Specifications* on page 148
- *OEM719 Interface Connector* on page 150

A.1 OEM719 Performance Specifications

All specifications subject to GNSS system characteristics.

Table 14: OEM719 Receiver Performance

Position Accuracy ¹	Single point L1	1.5 m RMS
	Single point L1/L2	1.2 m RMS
	SBAS ²	60 cm RMS
	DGPS	40 cm RMS
	TerraStar-L ^{3, 4}	40 cm RMS
	TerraStar-C PRO ^{3, 4}	2.5 cm RMS
	TerraStar-X ^{3, 4}	2.0 cm RMS
	RTK	1 cm + 1 ppm RMS
Signals Tracked	GPS	L1 C/A, L1C, L2C, L2P, L5
	GLONASS	L1 C/A, L2 C/A, L2P, L3
	BeiDou	B1I, B1C, B2I, B2a, B2b, B3I
	Galileo	E1, E5 AltBOC, E5a, E5b, E6
	NavIC (IRNSS)	L5
	QZSS	L1 C/A, L1C, L1S, L2C, L5, L6
	SBAS	L1, L5
	L-Band ⁵	Up to 5 channels
Time to First Fix	Hot: <20 s (Almanac and recent ephemeris saved and approximate position and time entered)	
	Cold: <39 s (No almanac or ephemeris and no approximate position or time)	

¹Typical values. All position and velocity RMS values are based on Horizontal position accuracy. Performance specifications are subject to GNSS system characteristics, Signal-in-Space (SIS) operational degradation, ionospheric and tropospheric conditions, satellite geometry, baseline length, multipath effects and the presence of intentional or unintentional interference sources.

²GPS-only.

³Requires a TerraStar subscription which is available direct from NovAtel novatel.com/products/gps-gnss-correction-services/terraStar-correction-services.

⁴Performance dependent on local observing conditions.

⁵Currently the receiver can track up to 3 L-Band channels.

Signal Reacquisition	<0.5 s L1 (typical) <1.0 s L2 and L5 (typical)			
Data Rates	Measurements	up to 100 Hz		
	Position	up to 100 Hz		
Time Accuracy ¹	20 ns RMS			
Velocity Accuracy	<0.03 m/s RMS			
Measurement Precision ²		Code	Carrier	
	GPS	L1 C/A	4 cm	0.5 mm
		L2 P(Y)	8 cm	1.0 mm
		L2C	8 cm	0.5 mm
		L5	3 cm	0.5 mm
	GLONASS	L1 C/A	8 cm	1.0 mm
		L2 P	8 cm	1.0 mm
		L2 C/A	8 cm	1.0 mm
	Galileo	E1	3 cm	0.5 mm
		E5a	3 cm	0.75 mm
		E5b	3 cm	0.75 mm
		E5 AltBOC	3 cm	0.75 mm
		E6	3 cm	0.75 mm
	BeiDou	B1I	4 cm	0.5 mm
		B1C	3 cm	0.5 mm
		B2I	4 cm	0.5 mm
		B2a	3 cm	0.5 mm
		B2b ³	3 cm	0.5 mm
B3I		4 cm	0.5 mm	
Velocity Limit ⁴	515 m/s			

¹Time accuracy does not include biases due to RF or antenna delay.

²Measurement precision should be compared with measurements using the same correlator spacing.

³Under good CN0 conditions, e.g. 44 dBHz.

⁴Export licensing restricts operation to a maximum of 515 metres per second, message output impacted above 500 m/s.

A.2 OEM719 Mechanical Specifications

- *Figure 42: OEM719 Dimensions below*
- *Figure 43: OEM719 Keep-outs on the next page*
- *Figure 44: OEM719A Dimensions on page 139*
- *Figure 45: OEM719A Keep-outs on page 140*
- *Figure 46: OEM719B Dimensions on page 141*
- *Figure 47: OEM719B Keep-outs on page 142*
- *Figure 48: OEM719 Mounting Surface on page 143*

Figure 42: OEM719 Dimensions

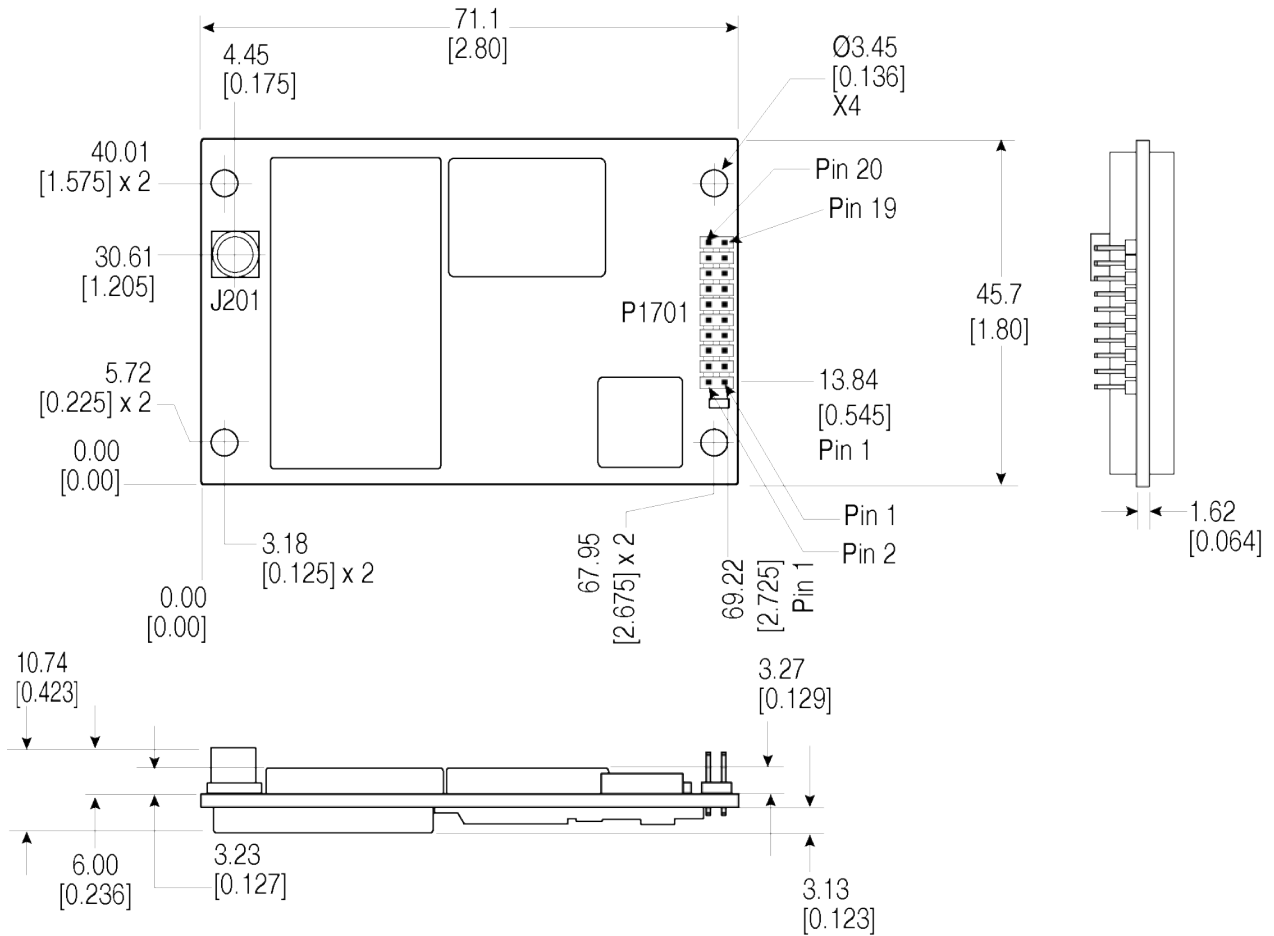

Notes: 719

Dimensions are in millimetres [inches].

Connectors:

(a) J201 MCX jack receptacle, straight (Johnson P/N 133-3711-202 or Samtec P/N MCX-J-P-HST-SMI or equivalent)

(b) P1701 2x10 header, 2 mm pitch (Samtec P/N TMM-110-03-G-D)

Figure 43: OEM719 Keep-outs

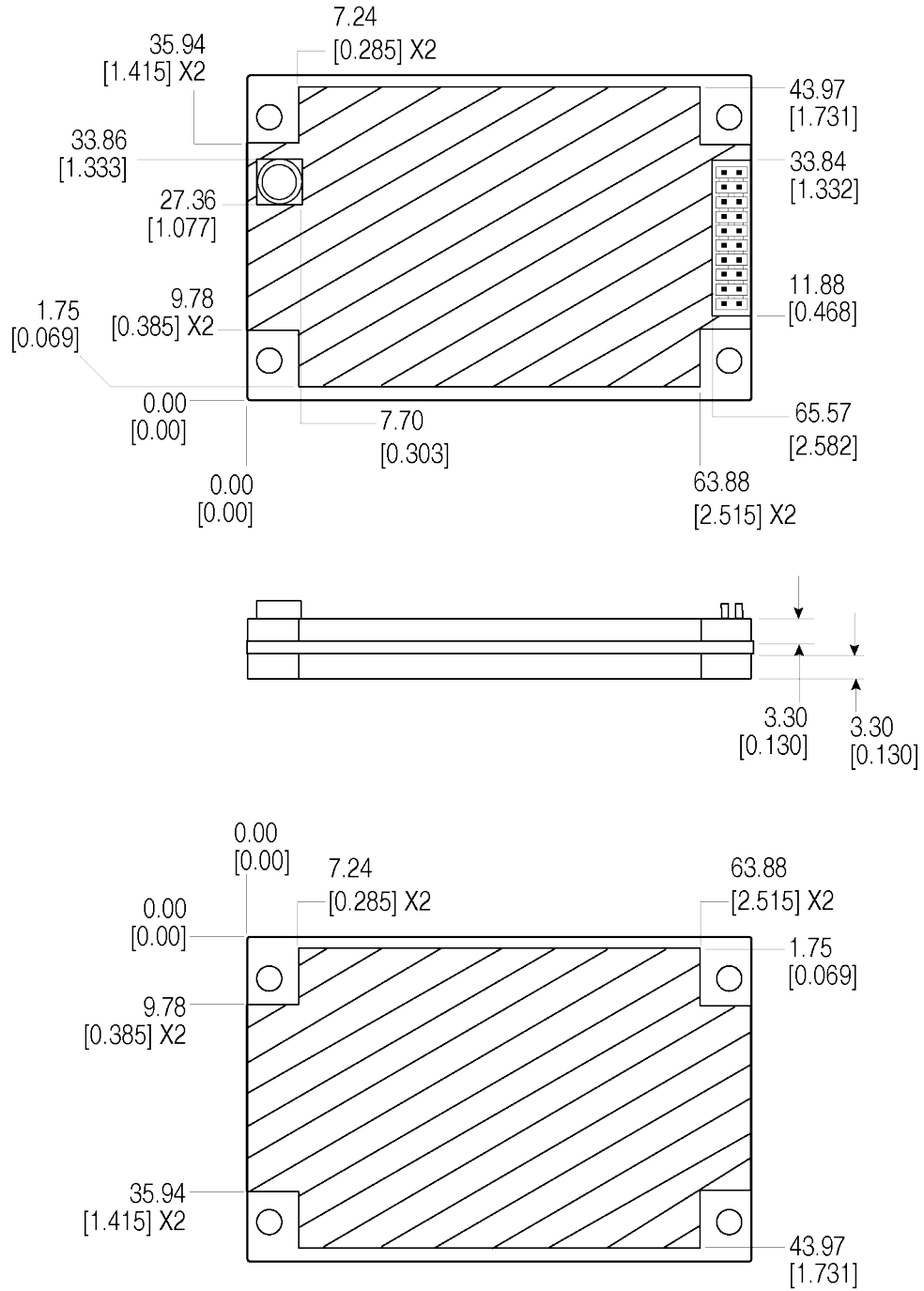

Dimensions are in millimetres [inches].

Figure 44: OEM719A Dimensions

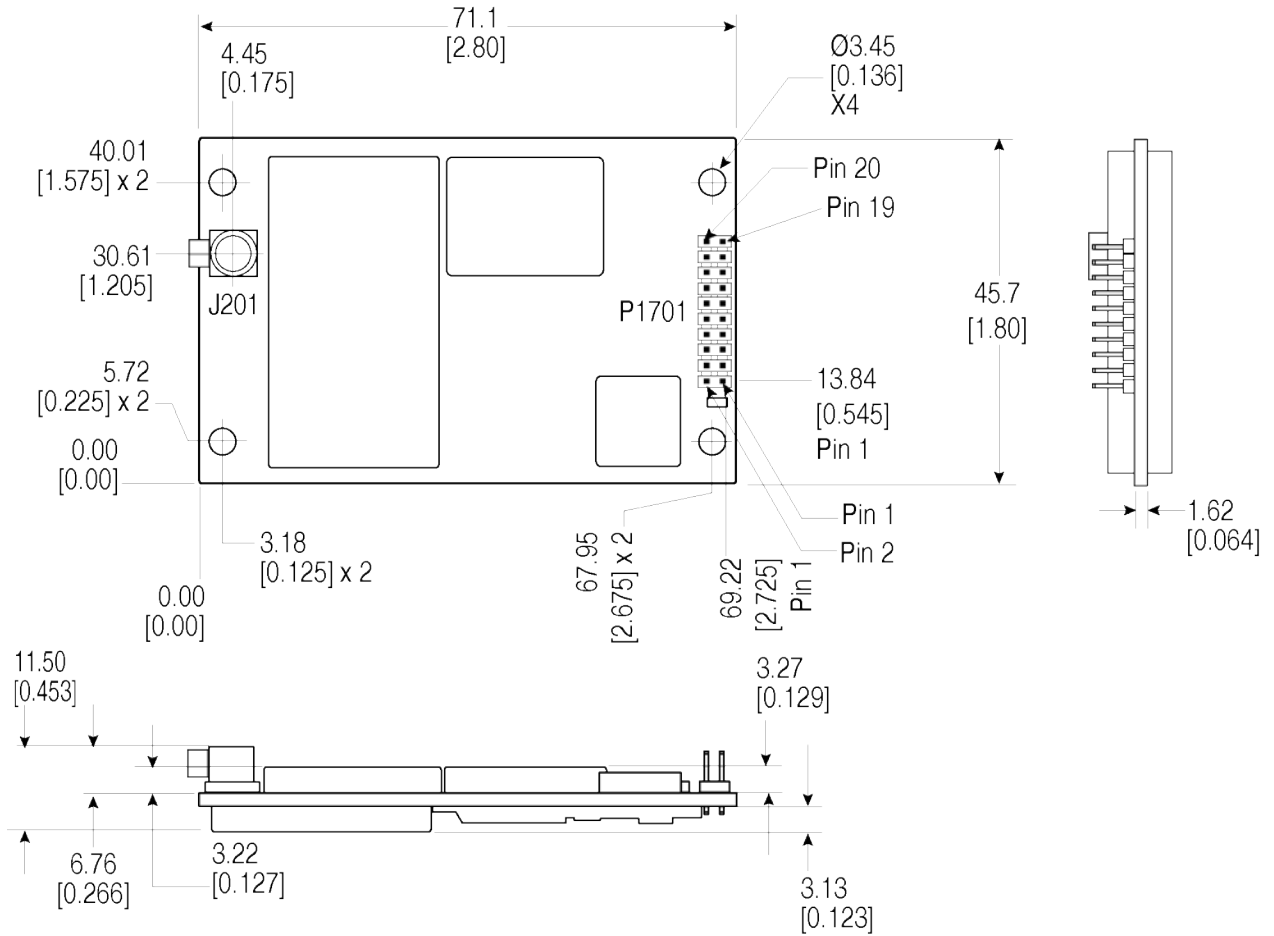

Notes: 719A

Dimensions are in millimetres [inches].

Connectors:

- (a) J201 MCX jack receptacle, right angle (Samtec P/N MCX-J-P-H-RA-SMI or equivalent)
- (b) P1701 2x10 header, 2 mm pitch (Samtec P/N TMM-110-03-G-D)

Figure 45: OEM719A Keep-outs

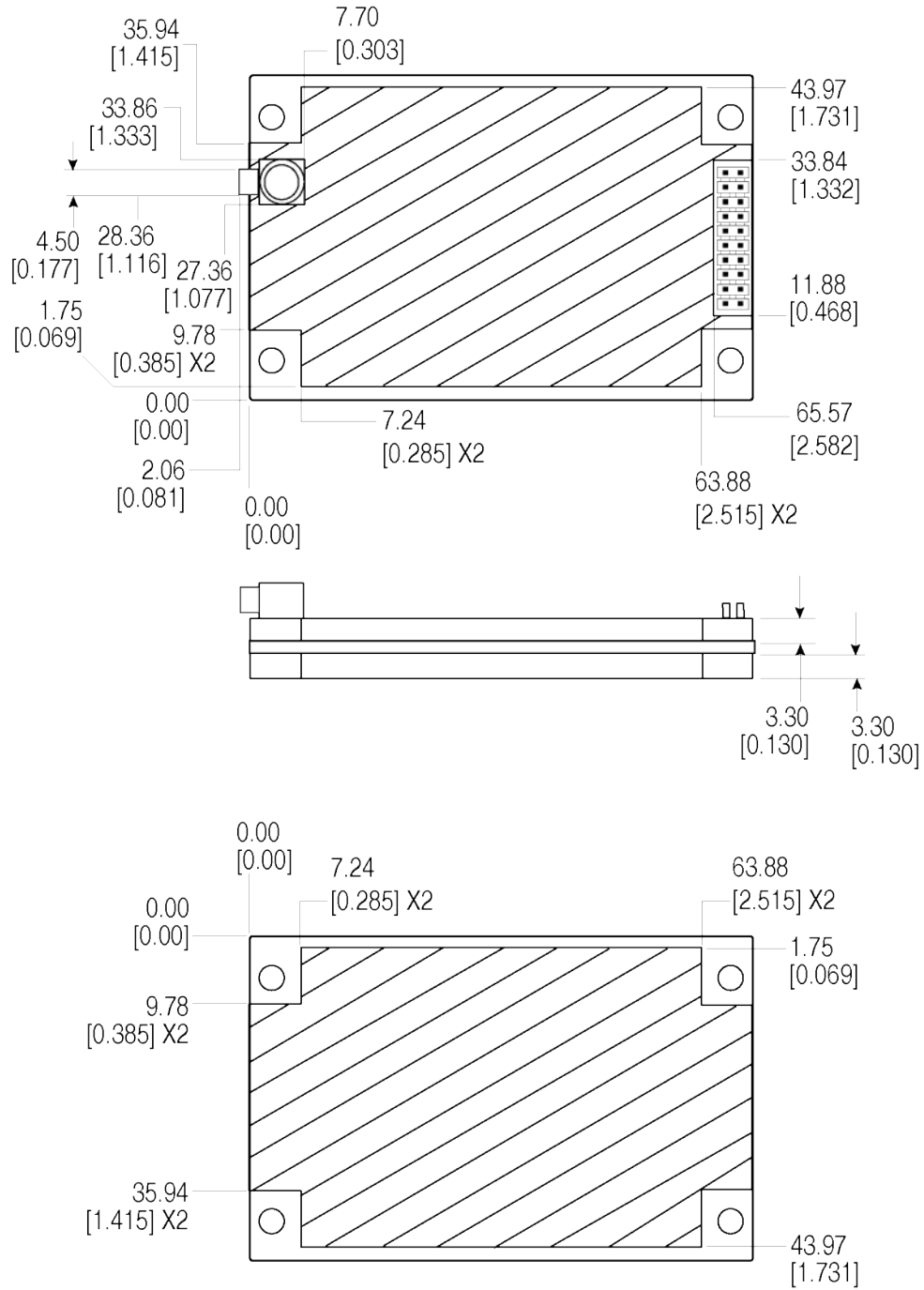

Dimensions are in millimetres [inches].

Figure 46: OEM719B Dimensions

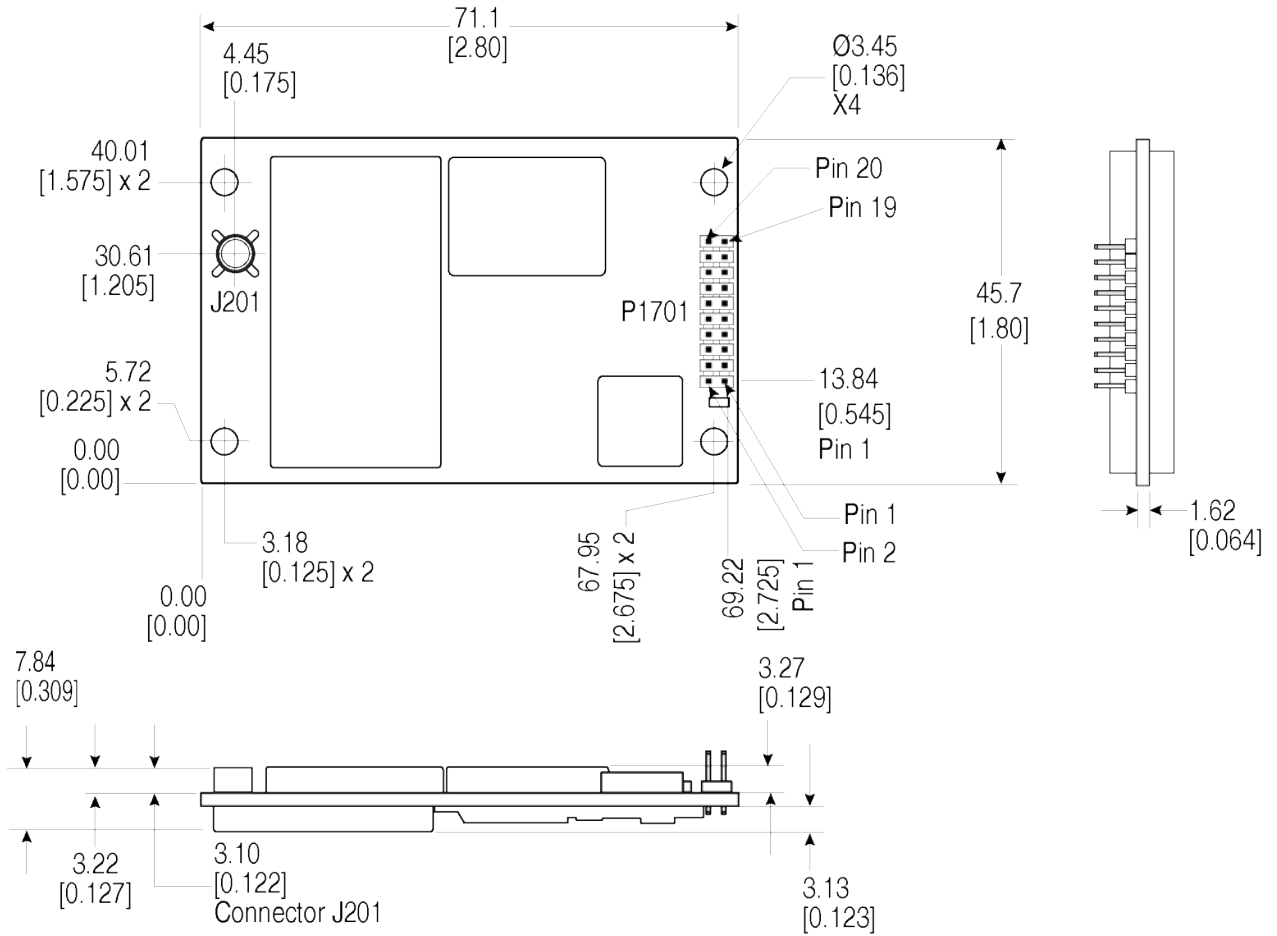

Notes: 719B

Dimensions are in millimetres [inches].

Connectors:

(a) J201: MMBX jack receptible, straight (Huber+Shuhner 82-MMBX-S50-0-1/111_NM)

(b) P1701: 2x10 header, 2 mm pitch (Samtec P/N TMM-110-03-G-D)

Figure 47: OEM719B Keep-outs

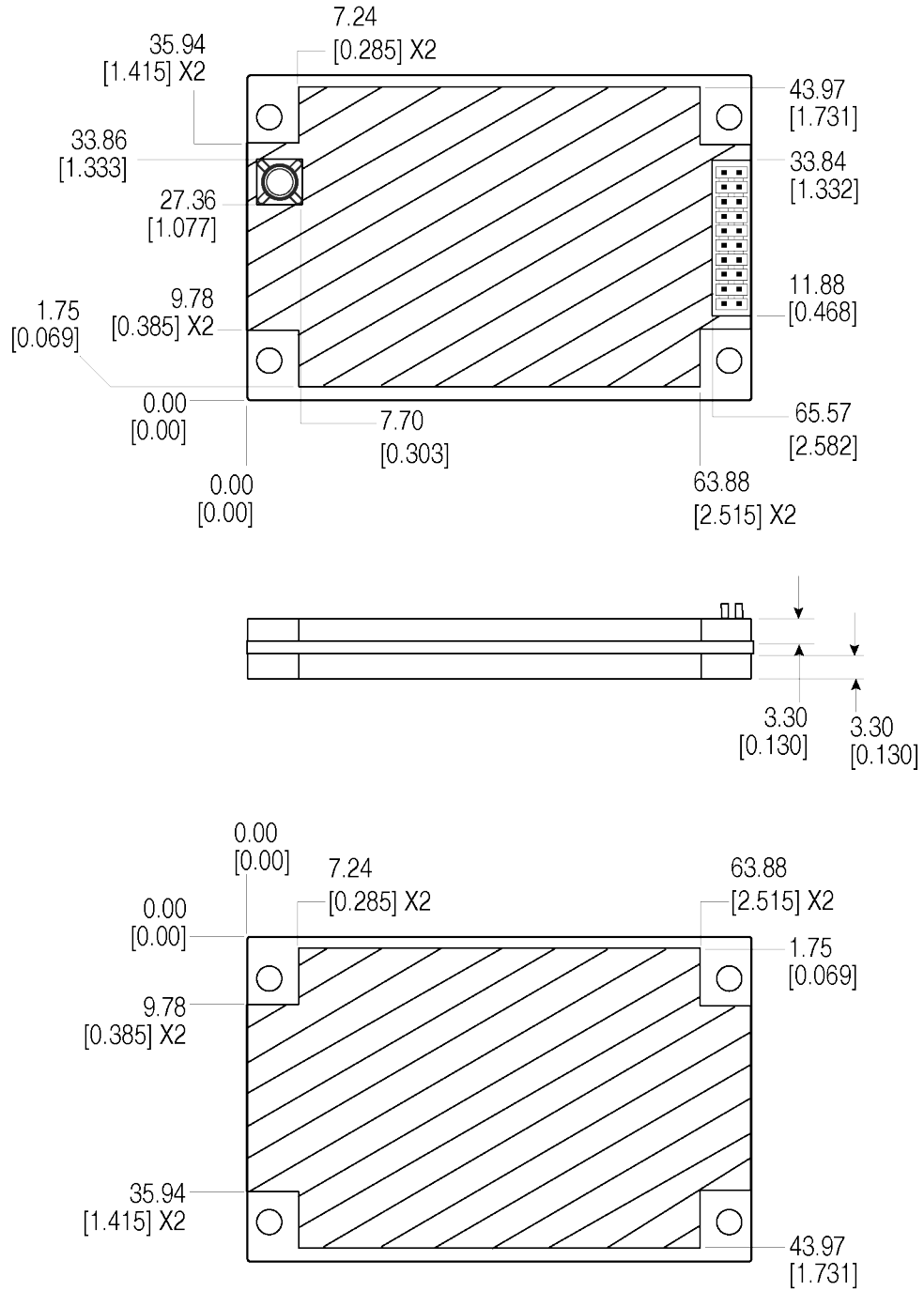

Dimensions are in millimetres [inches].

Figure 48: OEM719 Mounting Surface

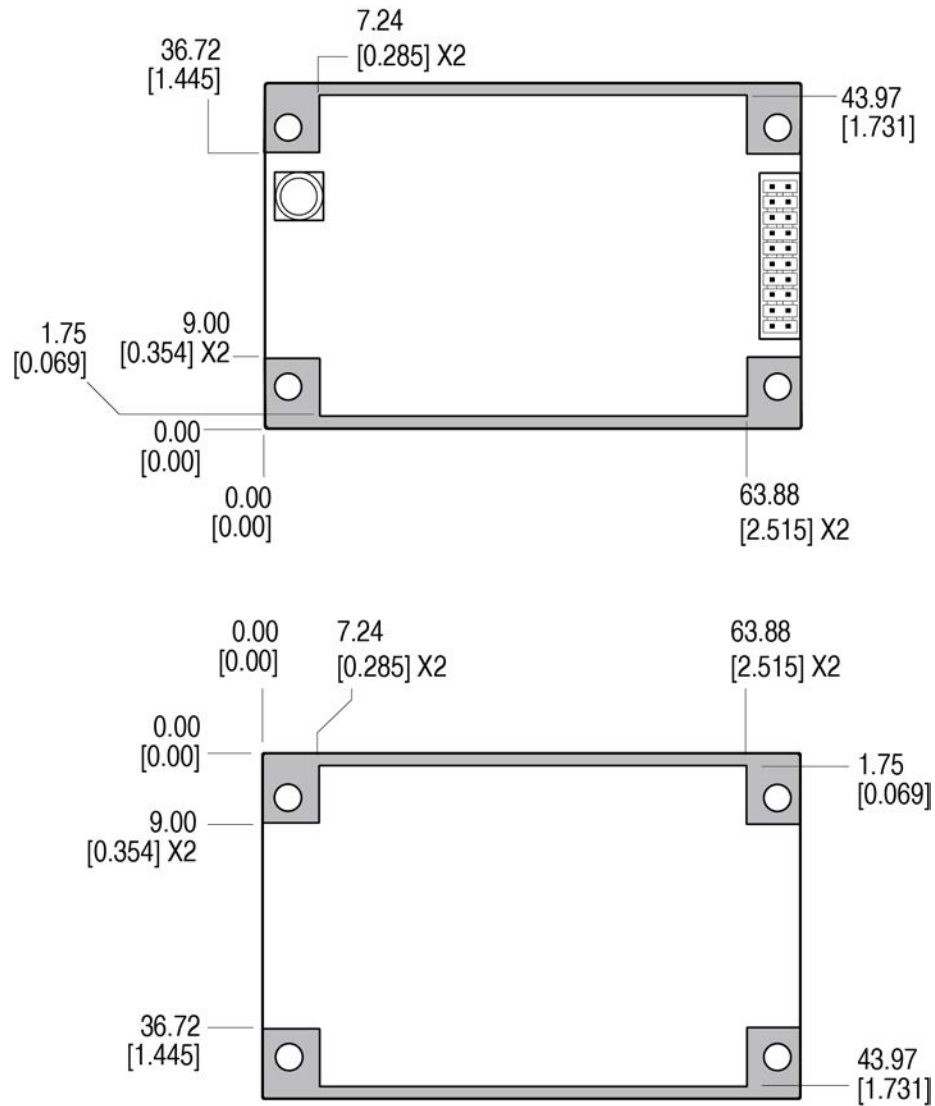

Dimensions are in millimetres [inches].

The mounting surfaces are shown in gray. These mounting surfaces apply to all variants of the OEM719.

These mounting surfaces are designed to work with mounting rails. For information about mounting the OEM719, refer to *Mounting the Printed Circuit Board* on page 31.



Assembly tolerances must be considered when using mounting rail features.



For information about the recommended mating connector, refer to *Table 2: OEM7 Communication and I/O Connectors* on page 40.

A.3 OEM719 Electrical and Environmental Specifications

Table 15: OEM719 Environmental Specifications

Operating Temperature	-40°C to +85°C
Storage Temperature	-55°C to +95°C
Humidity	95% non-condensing
Random Vibration	MIL-STD-810G, Method 514.6, Category 24 (20 g RMS) ¹
Sinusoidal Vibration	IEC 60068-2-6
Bump	ISO 9022-31-06 (25 g)
Shock	
Operating	MIL-STD-810G, Method 516.6 (40 g)
Non-operating	MIL-STD-810G, Method 516.6 (75 g)
Acceleration, Operating	MIL-STD-810G (CH1), Method 513.7 (16 g)

Table 16: OEM719 Power Requirements



Voltage	+3.3 VDC ±5%
Allowable Input Voltage Ripple	100 mV p-p maximum
Power Consumption	<p>0.9 W typical, GPS L1 only 1.3 W typical, GPS L1/L2, GLONASS L1/L2 1.8 W typical, all constellations/all frequencies, plus L-Band</p> <div style="border: 1px solid black; padding: 5px; margin-top: 10px;">  <p>These are typical values using serial ports without interference mitigation. Values can change with the number of satellites in view, firmware version, data logging rates and features in use. Use them as a guide for what you might expect but not as absolute values.</p> </div>
Inrush Current	1.71 A for less than 1.5 ms (typical)

Table 17: OEM719 RF Input/LNA Power Output

Antenna Connector	OEM719	MCX female, 50 Ω nominal impedance
	OEM719A	Right angle, MCX female, 50 Ω nominal impedance
	OEM719B	MMBX female, 50 Ω nominal impedance

¹Requires mechanical mounting rails to meet 20 g; meets 7.7 g without rails.

Cascaded antenna LNA gain (before receiver)	Firmware 7.04 and later	HDR disabled	+15 dB to +55 dB, 26 dB typical
		HDR enabled	+20 dB to +55 dB, 30 dB typical
	Firmware before 7.04	HDR disabled	+15 dB to +40 dB, 26 dB typical
		HDR enabled	+20 dB to +40 dB, 30 dB typical
RF Input Frequencies	GPS L1:	1575.42 MHz	
	GPS L2:	1227.60 MHz	
	GPS L5:	1176.45 MHz	
	GLONASS L1:	1593-1610 MHz	
	GLONASS L2:	1237-1254 MHz	
	GLONASS L3:	1202.025 MHz	
	Galileo E1:	1575.42 MHz	
Galileo E5a:	1176.45 MHz		
Galileo E5b:	1207.14 MHz		
Galileo E5:	1191.795 MHz		
Galileo E6:	1278.75 MHz		
BeiDou B1I:	1561.098 MHz		
	BeiDou B1C:	1575.42 MHz	
	BeiDou B2I:	1207.14 MHz	
	BeiDou B2a:	1176.45 MHz	
	BeiDou B2b:	1207.14 MHz	
	BeiDou B3I:	1268.52 MHz	
L-Band:	1525 to 1560 MHz		
LNA Power	<p>+5.0 VDC \pm5%, 0 mA to 200 mA (supplied by card through center conductor of RF connector).</p> <p>LNA Power is generated from the 3.3 V supply input for the OEM719.</p> <div style="border: 1px solid black; padding: 5px; margin-top: 10px;">  Pin 1 of P1701 is not electrically connected on the OEM719. This was the external LNA power input (LNA-PWR) on the OEM615. </div>		

A.4 OEM719 Data Communication Specifications

Table 18: OEM719 Data Communication Interfaces

COM1	
Electrical format	LVC MOS
Data rates ¹	2400, 4800, 9600 (default), 19200, 38400, 57600, 115200, 230400 or 460800 bit/s.
Signals supported	COM1_Tx, COM1_Rx
Electrostatic discharge protection	No
COM2	
Electrical format	LVC MOS
Data rates ¹	2400, 4800, 9600 (default), 19200, 38400, 57600, 115200, 230400 or 460800 bit/s.
Signals supported	COM2_Tx, COM2_Rx
Electrostatic discharge protection	No
COM3	
Electrical format	LVC MOS ²
Data rates ¹	2400, 4800, 9600 (default), 19200, 38400, 57600, 115200, 230400 or 460800 bit/s.
Signals supported	COM3_Tx, COM3_Rx
Electrostatic discharge protection	No
CAN Bus	
Electrical format	LVC MOS (requires external CAN transceiver) ³

¹Data rates higher than 115200 bit/s are not supported by standard PC hardware. Special computer hardware may be required for higher rates, including 230400 bit/s and 460800 bit/s.

²COM3 is disabled by default.

³CAN1 Rx and Tx signals are internally multiplexed with VARF and Event2, respectively. Both VARF and Event2 are enabled by default. To enable CAN functionality, the following commands must be issued before configuring the CAN1 port:

```
EVENTOUTCONTROL MARK1 DISABLE
EVENTINCONTROL MARK2 DISABLE
```

These commands, together with the commands to configure the CAN1 port, can be saved using SAVECONFIG.

Data rates	250, 500 or 1000 kb/s CAN Bus throughput is determined by slowest device on the bus
Signals supported	CAN1Tx, CAN1Rx, CAN2Tx, CAN2Rx
USB	
Electrical format	Conforms to USB 2.0
Data rates	Full-speed (12 Mb/s)
Signals supported	USB D (+), USB D (-)

A.5 OEM719 Strobe Specifications

Table 19: OEM719 Strobe Description



Strobes	Input/Output	Factory Default	Comment
Event1 (Mark 1)	Input Leading edge triggered	Active low	<p>An input mark for which a pulse greater than 150 ns triggers certain logs to be generated. (Refer to the MARKPOS and MARK1TIME logs and ONMARK trigger.) Polarity is configurable using the EVENTINCONTROL command. The mark inputs have 10K pull-up resistors to 3.3 V</p> <div style="border: 1px solid black; padding: 5px;">  Event1 is the default behavior for pin 9 of connector P1701. The secondary behavior for pin 9 is COM3_Tx. If COM3 is enabled, the Event1 input is disabled. </div>
Event2 (Mark 2)	Input Leading edge triggered	Active low	<p>An input mark for which a pulse greater than 150 ns triggers certain logs to be generated (see the MARK2POS and MARK2TIME logs). Polarity is configurable using the EVENTINCONTROL command. The mark inputs have 10K pull-up resistors to 3.3 V</p> <div style="border: 1px solid black; padding: 5px;">  Event2 is the default behavior for pin 7 of connector P1701. The secondary behavior for pin 7 is CAN1Tx. If CAN1 is enabled, the Event2 input is disabled. </div>
PPS	Output	Active low	<p>A time synchronization output. This is a pulse where the leading edge is synchronized to receiver-calculated GNSS Time. The polarity, period and pulse width can be configured using the PPSCONTROL command</p>
PV (Position Valid)	Output	Active high	<p>Indicates a valid GNSS position solution is available.</p>
nRESET_IN	Input	Active low	<p>Reset signal input from external system; active low.</p> <p>This pin must be held low for >20 μs while stable power is already applied, to reset the OEM719 card.</p> <p>It is recommended to hold the nRESET_IN pin low for a >150 ms when initially applying power to the card, giving the power supply time to stabilize before the card starts to boot.</p>
VARF (Variable Frequency)	Output	Active low	<p>A programmable variable frequency output ranging from 0 - 50 MHz (refer to the EVENTOUTCONTROL command)</p> <div style="border: 1px solid black; padding: 5px;">  VARF is the default behavior for pin 6 of connector P1701. The secondary behavior for pin 6 is CAN1Rx. If CAN1 is enabled, the VARF output is disabled. </div>

Table 20: OEM719 Strobe Electrical Specification

Strobe	Sym	Min (V)	Typ (V)	Max (V)	Current (mA)
Event1 (Mark1)	V _{IL}			0.7	-
Event2 (Mark2)	V _{IH}	2.1			
PPS	V _{OL}			0.4	16
	V _{OH}	2.4			
PV	V _{OL}			0.4	4
	V _{OH}	2.9			
nRESET_IN	V _{IL}			0.8	-
	V _{IH}	2.3			
VARF	V _{OL}			0.4	4
	V _{OH}	2.9			

A.6 OEM719 Interface Connector

A.6.1 P1701 Main Connector 20-Pin Header

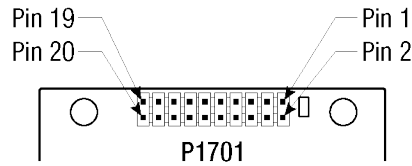

For information about the recommended mating connector, refer to *Table 2: OEM7 Communication and I/O Connectors* on page 40.

Pin	Signal Name	Signal Type	Signal Direction	V _{IL} Max (V)	V _{IH} Min (V)	V _{OL} Max (V)	V _{OH} Min (V)	Drive (mA)	Description
1	NC	-	-	-	-	-	-	-	No internal connection on OEM719 receiver. (This pin was the supply feed for the external GNSS antenna on the OEM6 family. The OEM719 generates the antenna power from the 3.3V supply input.)
2	3V3	Power	-	-	-	-	-	-	3.3 V \pm 5% supply voltage. This is monitored by the receiver itself. (Out-of-tolerance supply inputs may generate warning or error messages.)
3	USB_D-	Analog	Input/Output	-	-	-	-	-	This is one half of a USB differential pair (pins 3 and 4), match lengths and route as 90 Ω differential pair if USB is used.

Pin	Signal Name	Signal Type	Signal Direction	V _{IL} Max (V)	V _{IH} Min (V)	V _{OL} Max (V)	V _{OH} Min (V)	Drive (mA)	Description
4	USB_D+/ RXD3	Analog /3.3V CMOS	USB_D+: Input/ Output	-	-	-	-	-	<p>This pin is internally multiplexed. USB_D+ is the default.</p> <p>USB_D+: This is one half of a USB differential pair (pins 3 and 4), match lengths and route as 90 Ω differential pair if USB is used.</p> <p>RXD3: COM3 Receive Data (UART). Internal weak (40 kΩ to 100 kΩ) pullup.</p>
			RXD3 Input	0.7	2.1	-	-	-	
5	nRESET_IN	3.3V CMOS	Input	0.8	2.3	-	-	-	<p>Active Low.</p> <p>Resets the OEM719 receiver card. This pin must be held low for >20 μs while stable power is already applied, to reset the OEM719 card.</p> <p>It is recommended to hold the nRESET_IN pin low for a >150 ms when initially applying power to the card, giving the power supply time to stabilize before the card starts to boot.</p> <p>Internal 10 kΩ pullup.</p>
6	VARF/ CAN1RX	3.3V CMOS	VARF: Output	-	-	0.4	2.9	4	<p>This pin is internally multiplexed. VARF is the default.</p> <p>VARF: Variable Frequency Output. Rising or falling edge active.</p> <p>CAN1RX: a CMOS-level signal, requiring an external CAN transceiver.</p> <p>Internal 10 kΩ pullup.</p>
			CAN1RX: Input	0.7	2.1	-	-	-	

Pin	Signal Name	Signal Type	Signal Direction	V _{IL} Max (V)	V _{IH} Min (V)	V _{OL} Max (V)	V _{OH} Min (V)	Drive (mA)	Description
7	EVENT2/ CAN1TX	3.3V CMOS	EVENT2: Input	0.7	2.1	-	-	-	This pin is internally multiplexed. EVENT2 is the default. EVENT2: Rising edge triggered.
			CAN1TX: Output	-	-	0.4	2.9	4	CAN1TX is a CMOS-level signal, requiring an external CAN transceiver. Internal 10 kΩ pullup.
8	CAN2RX	3.3V CMOS	Input	0.7	2.1	-	-	-	CAN2RX is a CMOS-level signal, requiring an external CAN transceiver.
9	EVENT1/ TXD3	3.3V CMOS	EVENT1: Input	0.7	2.1	-	-	-	This pin is internally multiplexed. EVENT1 is the default. EVENT1: Rising edge triggered.
			TXD3: Output	-	-	0.4	2.9	4	TXD3: COM3 Transmit Data (UART) Internal 10 kΩ pullup.
10	GND	Power	-	-	-	-	-	-	Supply Return (Ground)
11	TXD1	3.3V CMOS	Output	-	-	0.8	2.0	16	COM1 Transmit Data (UART)
12	RXD1	3.3V CMOS	Input	0.7	2.1	-	-	-	COM1 Receive Data (UART) Internal weak (40 kΩ to 100 kΩ) pullup.
13	GND	Power	-	-	-	-	-	-	Supply Return (Ground)
14	TXD2	3.3V CMOS	Output	-	-	0.4	2.9	4	COM2 Transmit Data (UART)
15	RXD2	3.3V CMOS	Input	0.7	2.1	-	-	-	COM2 Receive Data (UART) Internal weak (40 kΩ to 100 kΩ) pullup.
16	GND	Power	-	-	-	-	-	-	Supply Return (Ground)

Pin	Signal Name	Signal Type	Signal Direction	V _{IL} Max (V)	V _{IH} Min (V)	V _{OL} Max (V)	V _{OH} Min (V)	Drive (mA)	Description
17	PV	3.3V CMOS	Output	-	-	0.4	2.9	4	Active High. Position Valid Indicator. Indicates that the receiver has computed a position. Active high output.
18	GND	Power	-	-	-	-	-	-	Supply Return (Ground)
19	PPS	3.3V CMOS	Output	-	-	0.4	2.4	16	Rising or Falling Edge active. (Software-configurable active edge.) This pin can be configured to provide a GNSS-synchronized time output (commonly Pulse Per Second but can operate at other rates as well).
20	CAN2TX	3.3V CMOS	Output	-	-	0.4	2.9	4	CAN2TX is a CMOS-level signal, requiring an external CAN transceiver.

APPENDIX B OEM729 Technical Specifications

Table 21: OEM729 Physical Description

Size	60 mm x 100 mm x 9 mm
Weight	48 grams
NovAtel Part Number	Generic assembly OEM729 01019523

See the following sections for more information about the OEM729:

- *OEM729 Performance Specifications* on the next page
- *OEM729 Mechanical Specifications* on page 157
- *OEM729 Electrical and Environmental Specifications* on page 160
- *OEM729 Data Communication Specifications* on page 163
- *OEM729 Strobe Specifications* on page 165
- *OEM729 Interface Connectors* on page 167

B.1 OEM729 Performance Specifications

All specifications subject to GNSS system characteristics.

Table 22: OEM729 Receiver Performance

Position Accuracy ¹	Single point L1	1.5 m RMS
	Single point L1/L2	1.2 m RMS
	SBAS ²	60 cm RMS
	DGPS	40 cm RMS
	TerraStar-L ^{3, 4}	40 cm RMS
	TerraStar-C PRO ^{3, 4}	2.5 cm RMS
	TerraStar-X ^{3, 4}	2.0 cm RMS
	RTK	1 cm + 1 ppm RMS
Signals Tracked	GPS	L1 C/A, L1C, L2C, L2P, L5
	GLONASS	L1 C/A, L2 C/A, L2P, L3
	BeiDou	B1I, B1C, B2I, B2a, B2b, B3I
	Galileo	E1, E5 AltBOC, E5a, E5b, E6
	NavIC (IRNSS)	L5
	QZSS	L1 C/A, L1C, L1S, L2C, L5, L6
	SBAS	L1, L5
	L-Band ⁵	Up to 5 channels
Time to First Fix	Hot: <20 s (Almanac and recent ephemeris saved and approximate position and time entered)	
	Cold: <39 s (No almanac or ephemeris and no approximate position or time)	

¹Typical values. All position and velocity RMS values are based on Horizontal position accuracy. Performance specifications are subject to GNSS system characteristics, Signal-in-Space (SIS) operational degradation, ionospheric and tropospheric conditions, satellite geometry, baseline length, multipath effects and the presence of intentional or unintentional interference sources.

²GPS-only.

³Requires a TerraStar subscription which is available direct from NovAtel novatel.com/products/gps-gnss-correction-services/terraStar-correction-services.

⁴Performance dependent on local observing conditions.

⁵Currently the receiver can track up to 3 L-Band channels.

Signal Reacquisition	<0.5 s L1 (typical) <1.0 s L2 and L5 (typical)			
Data Rates	Measurements	up to 100 Hz		
	Position	up to 100 Hz		
Time Accuracy ¹	20 ns RMS			
Velocity Accuracy	<0.03 m/s RMS			
Measurement Precision ²		Code	Carrier	
	GPS	L1 C/A	4 cm	0.5 mm
		L2 P(Y)	8 cm	1.0 mm
		L2C	8 cm	0.5 mm
		L5	3 cm	0.5 mm
	GLONASS	L1 C/A	8 cm	1.0 mm
		L2 P	8 cm	1.0 mm
		L2 C/A	8 cm	1.0 mm
	Galileo	E1	3 cm	0.5 mm
		E5a	3 cm	0.75 mm
		E5b	3 cm	0.75 mm
		E5 AltBOC	3 cm	0.75 mm
		E6	3 cm	0.75 mm
	BeiDou	B1I	4 cm	0.5 mm
		B1C	3 cm	0.5 mm
		B2I	4 cm	0.5 mm
		B2a	3 cm	0.5 mm
		B2b ³	3 cm	0.5 mm
B3I		4 cm	0.5 mm	
Velocity Limit ⁴	515 m/s			

¹Time accuracy does not include biases due to RF or antenna delay.

²Measurement precision should be compared with measurements using the same correlator spacing.

³Under good CN0 conditions, e.g. 44 dBHz.

⁴Export licensing restricts operation to a maximum of 515 metres per second, message output impacted above 500 m/s.

B.2 OEM729 Mechanical Specifications

- *Figure 49: OEM729 Dimensions* below
- *Figure 50: OEM729 Keep-outs* on the next page
- *Figure 51: OEM729 Mounting Surfaces* on page 159

Figure 49: OEM729 Dimensions

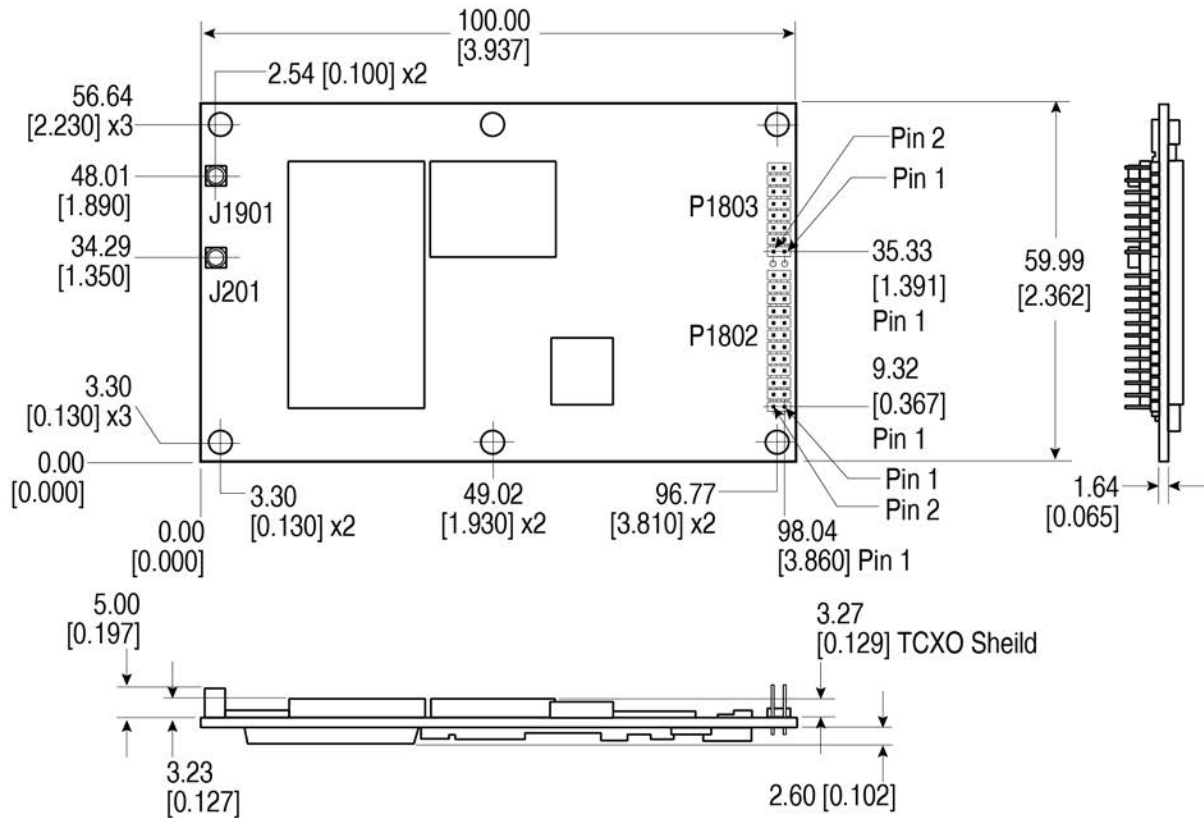

Notes:

Dimensions are in millimetres [inches].

Connectors:

(a) J201 and 1901 MMCX jack receptacle (Johnson P/N 135-3701-201 or Samtec P/N RSP-149374-01 or equivalent)

(b) P1802 2x12 header, 2 mm pitch (Samtec P/N TMM-112-03-G-D)

P1803 2x8 header, 2 mm pitch (Samtec P/N TMM-108-03-G-D)

Figure 50: OEM729 Keep-outs

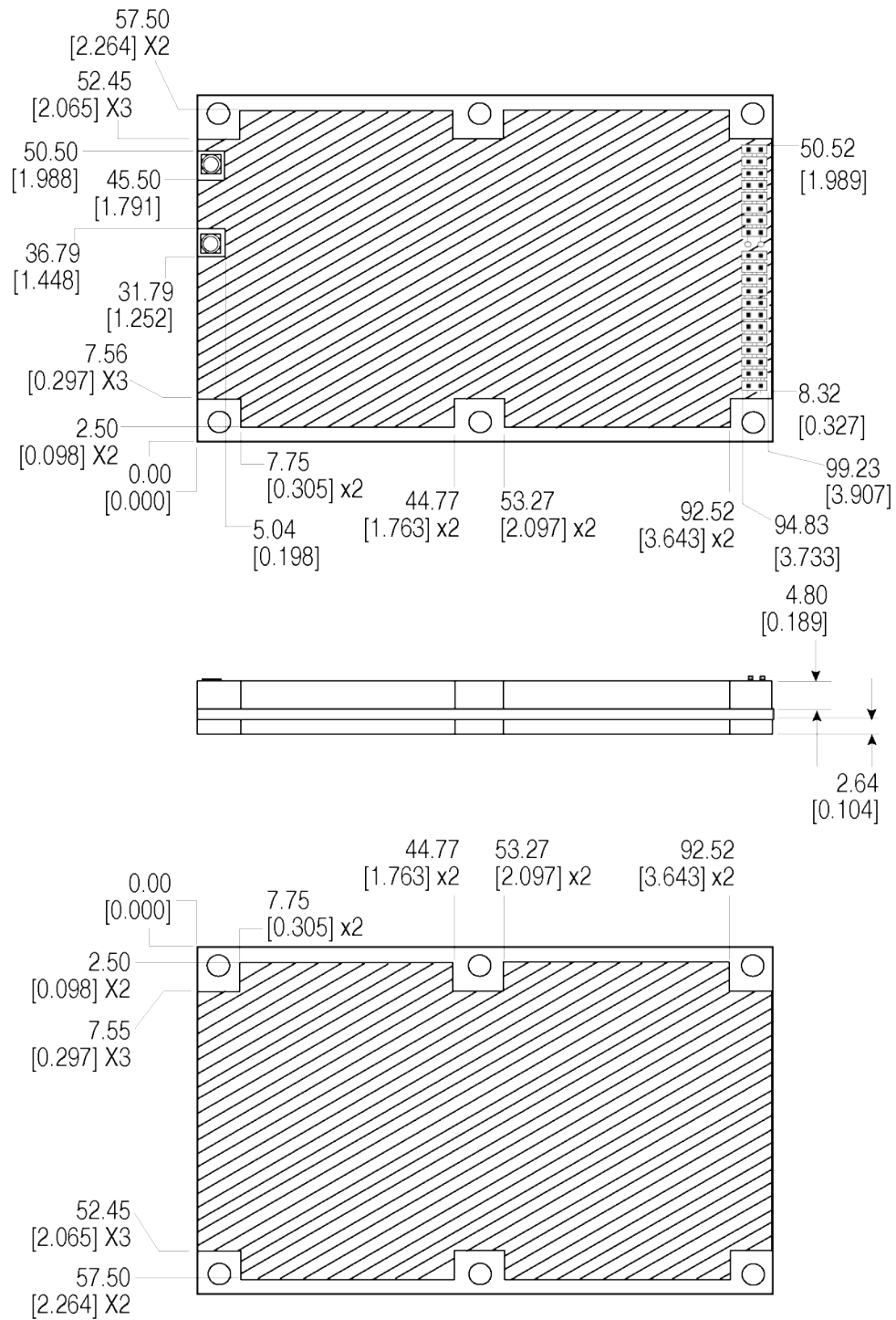

Dimensions are in millimetres [inches].

Figure 51: OEM729 Mounting Surfaces

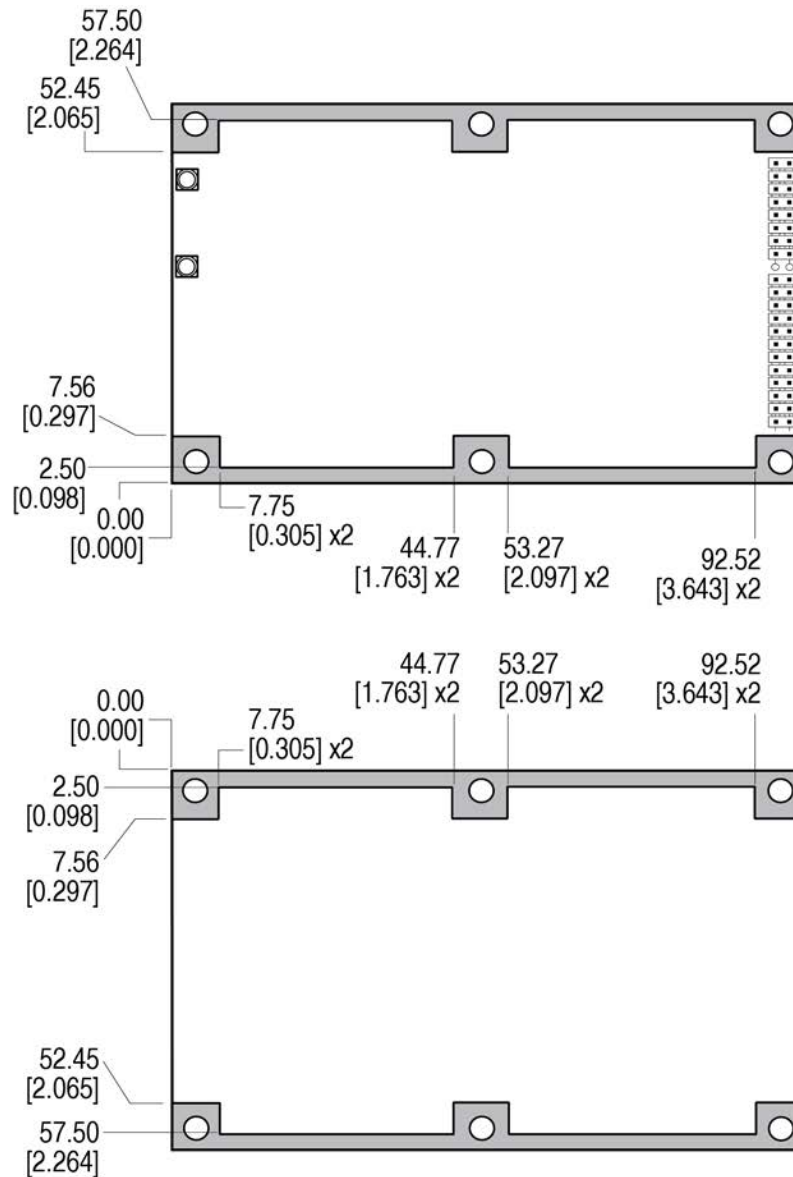

Dimensions are in millimetres [inches].

The mounting surfaces are shown in gray. For information about mounting the OEM729, refer to *Mounting the Printed Circuit Board* on page 31.



Assembly tolerances must be considered when using mounting rail features.



For information about the recommended mating connector, refer to *Table 2: OEM7 Communication and I/O Connectors* on page 40.

B.3 OEM729 Electrical and Environmental Specifications

Table 23: OEM729 Environmental Specifications

Operating Temperature	-40°C to +85°C
Storage Temperature	-55°C to +95°C
Humidity	95% non-condensing
Random Vibration	MIL-STD-810G, Method 514.6, Category 24 (20 g RMS)
Sinusoidal Vibration	IEC 60068-2-6
Bump	ISO 9022-31-06 (25 g)
Shock	
Operating	MIL-STD-810G, Method 516.6 (40 g)
Non-operating	MIL-STD-810G, Method 516.6 (75 g)
Acceleration	MIL-STD-810G (CH1), Method 513.7, (16 g)

Table 24: OEM729 Power Requirements

Voltage	+3.3 VDC \pm 5%
Allowable Input Voltage Ripple	100 mV p-p maximum
Power Consumption	<p>0.9 W typical, GPS L1 only 1.3 W typical, GPS L1/L2, GLONASS L1/L2 1.8 W typical, all constellations, all frequencies, plus L-Band</p> <div style="border: 1px solid black; padding: 5px; margin-top: 10px;">  <p>These are typical values using serial ports without interference mitigation. These values can change with the number of satellites in view, firmware version, data logging rates and features in use. Use them as a guide for what you might expect but not as absolute values</p> </div>
Inrush Current	2.0 A for less than 1.8 ms (typical)

Table 25: OEM729 RF Input/LNA Power Output

Antenna Connector	MMCX female, 50 Ω nominal impedance
-------------------	--

Cascaded antenna LNA gain (before receiver)	Firmware 7.04 and later	HDR disabled	+15 dB to +55 dB, 26 dB typical
		HDR enabled	+20 dB to +55 dB, 30 dB typical
	Firmware before 7.04	HDR disabled	+15 dB to +40 dB, 26 dB typical
		HDR enabled	+20 dB to +40 dB, 30 dB typical
RF Input Frequencies	GPS L1:	1575.42 MHz	
	GPS L2:	1227.60 MHz	
	GPS L5:	1176.45 MHz	
	GLONASS L1:	1593-1610 MHz	
	GLONASS L2:	1237-1254 MHz	
	GLONASS L3:	1202.025 MHz	
	Galileo E1:	1575.42 MHz	
Galileo E5a:	1176.45 MHz		
Galileo E5b:	1207.14 MHz		
Galileo E5:	1191.795 MHz		
Galileo E6:	1278.75 MHz		
BeiDou B1I:	1561.098 MHz		
	BeiDou B1C:	1575.42 MHz	
	BeiDou B2I:	1207.14 MHz	
	BeiDou B2a:	1176.45 MHz	
	BeiDou B2b:	1207.14 MHz	
	BeiDou B3I:	1268.52 MHz	
L-Band:	1545 to 1560 MHz ¹		
LNA Power	+5.0 VDC ±5%, 0 mA to 200 mA (supplied by card through center conductor of RF connector). LNA Power is generated from the 3.3 V supply input for the OEM729.		

Table 26: OEM729 External Oscillator Input

External Oscillator Connector	MMCX female, 50 Ω nominal impedance
External Clock input	Refer to the EXTERNALCLOCK command

¹For hardware releases 2.10 and later. For earlier hardware versions, the L-Band RF Input Frequency is 1525 to 1560 MHz.

Frequency	5 MHz or 10 MHz
Input Impedance	50 Ohm nominal
Input VSWR	<2:1
Signal Level	0 dBm minimum to +13.0 dBm maximum
Frequency Stability	±0.5 ppm maximum
Wave Shape	Sinusoidal

B.4 OEM729 Data Communication Specifications

Table 27: Data Communications Interface

COM1	
Electrical format	RS-232/RS-422
Data rates ¹	2400, 4800, 9600 (default), 19200, 38400, 57600, 115200, 230400 or 460800 bit/s.
Signals supported	COM1_Tx, COM1_Rx, COM1_RTS, COM1_CTS
Electrostatic discharge protection	Yes
COM2	
Electrical format	LVC MOS
Data rates ¹	2400, 4800, 9600 (default), 19200, 38400, 57600, 115200, 230400 or 460800 bit/s.
Signals supported	COM2_Tx, COM2_Rx, COM2_RTS, COM2_CTS
Electrostatic discharge protection	No
COM3	
Electrical format	LVC MOS ^{2, 3}
Data rates ¹	2400, 4800, 9600 (default), 19200, 38400, 57600, 115200, 230400 or 460800 bit/s.
Signals supported	COM3_Tx, COM3_Rx
Electrostatic discharge protection	No
CAN Bus	
Electrical Format	LVC MOS
Data rates	1 Mbps maximum. CAN Bus throughput is determined by slowest device on the bus

¹Data rates higher than 115200 bit/s are not supported by standard PC hardware. Special PC hardware may be required for higher rates, including 230400 bit/s and 460800 bit/s.

²Upon power-up, COM3 is enabled by default. COM3 is multiplexed with Event 2

³To enable EVENT2, issue the following commands:

```
INTERFACEMODE COM3 NONE NONE
EVENTINCONTROL MARK2 ENABLE
```

Signals supported	CAN1 and CAN2
USB	
Electrical format	Conforms to USB 2.0
Data rates	Full-speed (12 Mb/s)
Signals supported	USB D (+), USB D (-)
ETHERNET	
Physical layer	10BASE-T/100BASE-TX

B.5 OEM729 Strobe Specifications

Table 28: OEM729 Strobes Description

Strobes	Input/Output	Factory Default	Comment
ERROR	Output	Active high	Normally low. A high output on this pin indicates that the receiver is in an error state. For information about the cause of the error, log the RXSTATUS log.
Event1	Input Leading edge triggered	Active low	An input mark for which a pulse greater than 150 ns triggers certain logs to be generated. (Refer to the MARKPOS and MARK1TIME logs and ONMARK trigger.) Polarity is configurable using the EVENTINCONTROL command.
Event2 (Mark 2)	Input Leading edge triggered	Active low	An input mark for which a pulse greater than 150 ns triggers certain logs to be generated. (Refer to the MARK2POS and MARK2TIME logs.) Polarity is configurable using the EVENTINCONTROL command. <div style="border: 1px solid black; padding: 5px; background-color: #f0f0f0;">  Event2 is the default behavior for pin 7 of connector P1804. The secondary behavior for pin 7 is COM3_Rx. If COM3 is enabled, the Event2 input is disabled. </div>
PPS	Output	Active low	A time synchronization output. This is a pulse where the leading edge is synchronized to receiver calculated GNSS Time. The polarity, period and pulse width can be configured using the PPSCONTROL command
PV (Position Valid)	Output	Active high	Indicates a valid GNSS position solution is available.
nRESET_IN	Input	Active low	Reset signal input from external system; active low. This pin must be held low for >20 µs while stable power is already applied, to reset the OEM729 card. It is recommended to hold the nRESET_IN pin low for a >150 ms when initially applying power to the card, giving the power supply time to stabilize before the card starts to boot.
VARF (Variable Frequency)	Output	Active low	A programmable variable frequency output ranging from 0 Hz to 50 MHz (refer to the EVENTOUTCONTROL command)

Table 29: OEM729 Strobe Electrical Specifications

Strobe	Sym	Min (V)	Max (V)	Current (mA)
ERROR	V _{OL}		0.4	4
	V _{OH}	2.9		
Event1 (Mark) Event2 (Mark2)	V _{IL}		0.7	-
	V _{IH}	2.1		
PPS	V _{OL}		0.4	16
	V _{OH}	2.4		
PV	V _{OL}		0.4	4
	V _{OH}	2.9		
nRESET_IN	V _{IL}		0.8	-
	V _{IH}	2.3		
VARF	V _{OL}		0.4	4
	V _{OH}	2.9		

B.6 OEM729 Interface Connectors

B.6.1 P1802 Main Connector 24-Pin Header

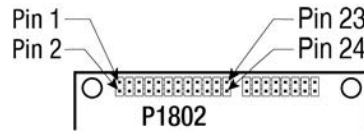

For information about the recommended mating connector, refer to *Table 2: OEM7 Communication and I/O Connectors* on page 40.

Pin	Signal Name	Signal Type	Signal Direction	V _{IL} Max (V)	V _{IH} Min (V)	V _{OL} Max (V)	V _{OH} Min (V)	Drive (mA)	Description
1	GND	PWR	-	-	-	-	-	-	Ground reference
2	USER1 ¹	3.3V CMOS	Input/Output	0.7	2.1	0.4	2.9	4	User GPIO. Internal 10 kΩ pulldown.
3	VARF	3.3V CMOS	Output	-	-	0.4	2.9	4	Variable Frequency output Edges can be synchronized to the GNSS time reference. Internal 10 kΩ pullup
4	PPS	3.3V CMOS	Output	-	-	0.4	2.4	16	Pulse Per Second output This signal defaults to one pulse per second but may be altered across a wide range of frequencies using software commands. Edges can be synchronized to GNSS time reference.
5	3V3	PWR	-	-	-	-	-	-	3.3 V ±5% supply input
6	3V3	PWR	-	-	-	-	-	-	3.3 V ±5% supply input

¹On power up, if pin 2 is set LOW or not connected, COM1 will be configured as RS-232. If pin 2 is set high then COM1 will be configured as RS-422

Pin	Signal Name	Signal Type	Signal Direction	V _{IL} Max (V)	V _{IH} Min (V)	V _{OL} Max (V)	V _{OH} Min (V)	Drive (mA)	Description
7	COM3_RX/ EVENT2 ¹	3.3V CMOS	Input	0.7	2.1	-	-	-	This pin is internally multiplexed. COM3_RX: COM3 receive data input. EVENT2 input. Rising or falling edge triggered. This is used to provide position or time data on an external trigger. Internal 10 kΩ pullup.
8	EVENT1	3.3V CMOS	Input	0.7	2.1	-	-	-	EVENT1 input Rising or falling edge triggered. This input is used to provide a position or time data log based on an external trigger. Internal 10 kΩ pullup.
9	ERROR	3.3V CMOS	Output	-	-	0.4	2.9	4	ERROR output Normally low. A high output on this pin indicates that the receiver is in an error state. Internal 10 kΩ pulldown.
10	PV	3.3V CMOS	Output	-	-	0.4	2.9	4	Position Valid output A high output on this pin indicates that the receiver has computed a valid GNSS position. Internal 10 kΩ pulldown.

¹Through firmware, the COM3 UART may be configured on pins 7 and 19.

Pin	Signal Name	Signal Type	Signal Direction	V _{IL} Max (V)	V _{IH} Min (V)	V _{OL} Max (V)	V _{OH} Min (V)	Drive (mA)	Description
11	COM2_CTS	3.3V CMOS	Input	0.7	2.1	-	-	-	COM2 Clear To Send input This is an optional flow control signal for the COM2 UART. Internal weak (40 kΩ to 100 kΩ) pullup.
12	nRESET_IN	Other	Input	0.8	2.3	-	-	-	Active Low. Resets the OEM729 receiver card. This pin must be held low for >20 μs while stable power is already applied, to reset the OEM729 card. It is recommended to hold the nRESET_IN pin low for a >150 ms when initially applying power to the card, giving the power supply time to stabilize before the card starts to boot. Internal 10 kΩ pullup.
13	COM2_RTS	3.3V CMOS	Output	-	-	0.4	2.9	4	COM2 Request To Send output This is an optional flow control signal for the COM2 UART.
14	COM2_RX	3.3V CMOS	Input	0.7	2.1	-	-	-	COM2 Receive Data input Internal weak (40 kΩ to 100 kΩ) pullup.

Pin	Signal Name	Signal Type	Signal Direction	V _{IL} Max (V)	V _{IH} Min (V)	V _{OL} Max (V)	V _{OH} Min (V)	Drive (mA)	Description
15	COM1_CTS/ COM1_RXD-	COM1_CTS: RS-232	Input	-	-	-	-	-	This pin is internally multiplexed. COM1_CTS is the default. COM1_CTS: COM1 Clear To Send input. This is an optional flow control signal for the COM1 UART (±25V tolerant). COM1_RXD-: This is one half of the COM1 RS-422 receive differential pair (2V differential typical)
		COM1_RXD-: RS-422	Input	-	-	-	-	-	
16	COM2_TX	3.3V CMOS	Output	-	-	0.4	2.9	4	COM2 Transmit Data output
17	COM1_RTS/ COM1_TXD-	COM1_RTS: RS-232	Output	-	-	-	-	-	This pin is internally multiplexed. COM1_RTS is the default. COM1_RTS: COM1 Request To Send output. This is an optional flow control signal for the COM1 UART (±25V tolerant). COM1_TXD-: This is one half of the COM1 RS-422 transmit differential pair. (2V differential typical)
		COM1_TXD-: RS-422	Output	-	-	-	-	-	
18	COM1_RX/ COM1_RXD+	COM1_RX: RS-232	Input	0.7	2.1	-	-	-	This pin is internally multiplexed. COM1_RX is the default. COM1_RX: COM1 Receive Data input (±25V tolerant). COM1_RXD+: This is one half of the COM1 RS-422 receive differential pair (2V differential typical).
		COM1_RXD+: RS-422	Input	-	-	-	-	-	

Pin	Signal Name	Signal Type	Signal Direction	V _{IL} Max (V)	V _{IH} Min (V)	V _{OL} Max (V)	V _{OH} Min (V)	Drive (mA)	Description
19	COM3_TX/USER0	3.3V CMOS	COM3_TX: Output	-	-	0.4	2.9	4	This pin is internally multiplexed. COM3_TX is the default. COM3_TX: COM3 Transmit Data output. USER0: User GPIO. Internal 10 kΩ pull-down.
			USER0: Input	0.7	2.1	-	-	-	
20	COM1_TX/COM1_TXD+	COM1_TX: RS-232	Output	-	-	-	-	-	This pin is internally multiplexed. COM1_TX is the default. COM1_TX: COM1 Transmit Data output. (±25V tolerant) COM1_TXD+: This is one half of the COM1 RS-422 transmit differential pair (2V differential typical)
		COM1_TXD+: RS-422	Output	-	-	-	-	-	
21	USB_D-	Analog	Input/Output	-	-	-	-	-	USB device signal. This is one half of the USB differential pair. USB_D+ and USB_D- must be length-matched and routed as a 90 Ω differential pair.
22	USB_D+	Analog	Input/Output	-	-	-	-	-	USB device signal. This is one half of the USB differential pair. USB_D+ and USB_D- must be length-matched and routed as a 90 Ω differential pair.
23	GND	PWR	-	-	-	-	-	-	Ground reference
24	GND	PWR	-	-	-	-	-	-	Ground reference

B.6.2 P1803 Expansion Connector 16-Pin Header

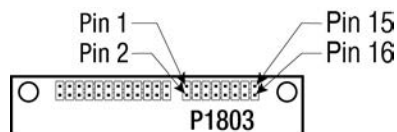

Pin	Signal Name	Signal Type	Signal Direction	V _{IL} Max (V)	V _{IH} Min (V)	V _{OL} Max (V)	V _{OH} Min (V)	Drive (mA)	Description
1	ETH_RD-	Analog	Input	-	-	-	-	-	This is one half of the Ethernet receive differential pair (100 Ω pair).
2	ETH_RD+	Analog	Input	-	-	-	-	-	This is one half of the Ethernet receive differential pair (100 Ω pair).
3	ETH_BIAS	PWR	-	-	-	-	-	-	Center tap power for Ethernet magnetics.
4	ETH_TD+	Analog	Output	-	-	-	-	-	This is one half of the Ethernet transmit differential pair (100 Ω pair).
5	ETH_TD-	Analog	Output	-	-	-	-	-	This is one half of the Ethernet transmit differential pair (100 Ω pair).
6	ETH_BIAS	PWR	-	-	-	-	-	-	Center tap power for Ethernet magnetics.
7	LED_A	3.3V CMOS	Output	-	-	0.4	2.9	8	Activity/Link indicator output. Polarity of the indicator signal is low. When there is an active link, the pin is low. When there is activity on the link, the pin outputs a blink signal.
8	LED_B	3.3V CMOS	Output	-	-	0.4	2.9	8	Speed indicator Low = 100 Mbps High = 10 Mbps
9	GND	PWR	-	-	-	-	-	-	Ground reference
10	CAN1TX	3.3V CMOS	Output	-	-	-	-	-	CAN1 Transmit data
11	CAN1RX	3.3V CMOS	Input	-	-	-	-	-	CAN1 Receive data
12	CAN2TX	3.3V CMOS	Output	-	-	-	-	-	CAN2 Transmit data
13	CAN2RX	3.3V CMOS	Input	-	-	-	-	-	CAN2 Receive data

Pin	Signal Name	Signal Type	Signal Direction	V _{IL} Max (V)	V _{IH} Min (V)	V _{OL} Max (V)	V _{OH} Min (V)	Drive (mA)	Description
14	UID	3.3V CMOS	Input	-	-	-	-	-	<p>USB Port Mode</p> <p>Leave this pin floating to ensure the USB port is in Device mode.</p> <p>Host mode is not currently supported on the OEM729.</p> <p>Internal 10 kΩ pull up</p>
15	VBUS	PWR	-	-	-	-	-	-	5V output for hosted USB devices
16	GND	PWR	-	-	-	-	-	-	Ground reference

APPENDIX C OEM7600 Technical Specifications

Table 30: OEM7600 Physical Description

Size	35 mm x 55 mm x 13 mm
Weight	31 grams
NovAtel Part Number	Generic assembly 01019807

See the following sections for more information about the OEM7600:

- *OEM7600 Performance Specifications* on the next page
- *OEM7600 Mechanical Specifications* on page 177
- *OEM7600 Electrical and Environmental Specifications* on page 179
- *OEM7600 Data Communication Specifications* on page 181
- *OEM7600 Strobe Specifications* on page 183
- *OEM7600 Interface Connector* on page 185

C.1 OEM7600 Performance Specifications

All specifications subject to GNSS system characteristics.

Table 31: OEM7600 Receiver Performance

Position Accuracy ¹	Single point L1	1.5 m RMS
	Single point L1/L2	1.2 m RMS
	SBAS ²	60 cm RMS
	DGPS	40 cm RMS
	TerraStar-L ^{3, 4}	40 cm RMS
	TerraStar-C PRO ^{3, 4}	2.5 cm RMS
	TerraStar-X ^{3, 4}	2.0 cm RMS
	RTK	1 cm + 1 ppm RMS
Signals Tracked	GPS	L1 C/A, L1C, L2C, L2P, L5
	GLONASS	L1 C/A, L2 C/A, L2P, L3
	BeiDou	B1I, B1C, B2I, B2a, B2b
	Galileo	E1, E5 AltBOC, E5a, E5b
	NavIC (IRNSS)	L5
	QZSS	L1 C/A, L1C, L1S, L2C, L5
	SBAS	L1, L5
	L-Band ⁵	Up to 5 channels
Time to First Fix	Hot: <20 s (Almanac and recent ephemeris saved and approximate position and time entered)	
	Cold: <39 s (No almanac or ephemeris and no approximate position or time)	

¹Typical values. All position and velocity RMS values are based on Horizontal position accuracy. Performance specifications are subject to GNSS system characteristics, Signal-in-Space (SIS) operational degradation, ionospheric and tropospheric conditions, satellite geometry, baseline length, multipath effects and the presence of intentional or unintentional interference sources.

²GPS-only.

³Requires a TerraStar subscription which is available direct from NovAtel novatel.com/products/gps-gnss-correction-services/terraStar-correction-services.

⁴Performance dependent on local observing conditions.

⁵Currently the receiver can track up to 3 L-Band channels.

Signal Reacquisition	<0.5 s L1 (typical) <1.0 s L2 and L5 (typical)			
Data Rates	Measurements	up to 100 Hz		
	Position	up to 100 Hz		
Time Accuracy ¹	20 ns RMS			
Velocity Accuracy	<0.03 m/s RMS			
Measurement Precision ²		Code	Carrier	
	GPS	L1 C/A	4 cm	0.5 mm
		L2 P(Y)	8 cm	1.0 mm
		L2C	8 cm	0.5 mm
		L5	3 cm	0.5 mm
	GLONASS	L1 C/A	8 cm	1.0 mm
		L2 P	8 cm	1.0 mm
		L2 C/A	8 cm	1.0 mm
	Galileo	E1	3 cm	0.5 mm
		E5a	3 cm	0.75 mm
		E5b	3 cm	0.75 mm
		E5 AltBOC	3 cm	0.75 mm
	BeiDou	B1I	4 cm	0.5 mm
		B1C	3 cm	0.5 mm
		B2I	4 cm	0.5 mm
B2a		3 cm	0.5 mm	
B2b ³		3 cm	0.5 mm	
Velocity Limit ⁴	515 m/s			

¹Time accuracy does not include biases due to RF or antenna delay.

²Measurement precision should be compared with measurements using the same correlator spacing.

³Under good CN0 conditions, e.g. 44 dBHz.

⁴Export licensing restricts operation to a maximum of 515 metres per second, message output impacted above 500 m/s.

C.2 OEM7600 Mechanical Specifications

- *Figure 52: OEM7600 Dimensions* below
- *Figure 53: OEM7600 Interface Board Details* on the next page



In the following diagrams, the dimensions are in millimetres.

Figure 52: OEM7600 Dimensions

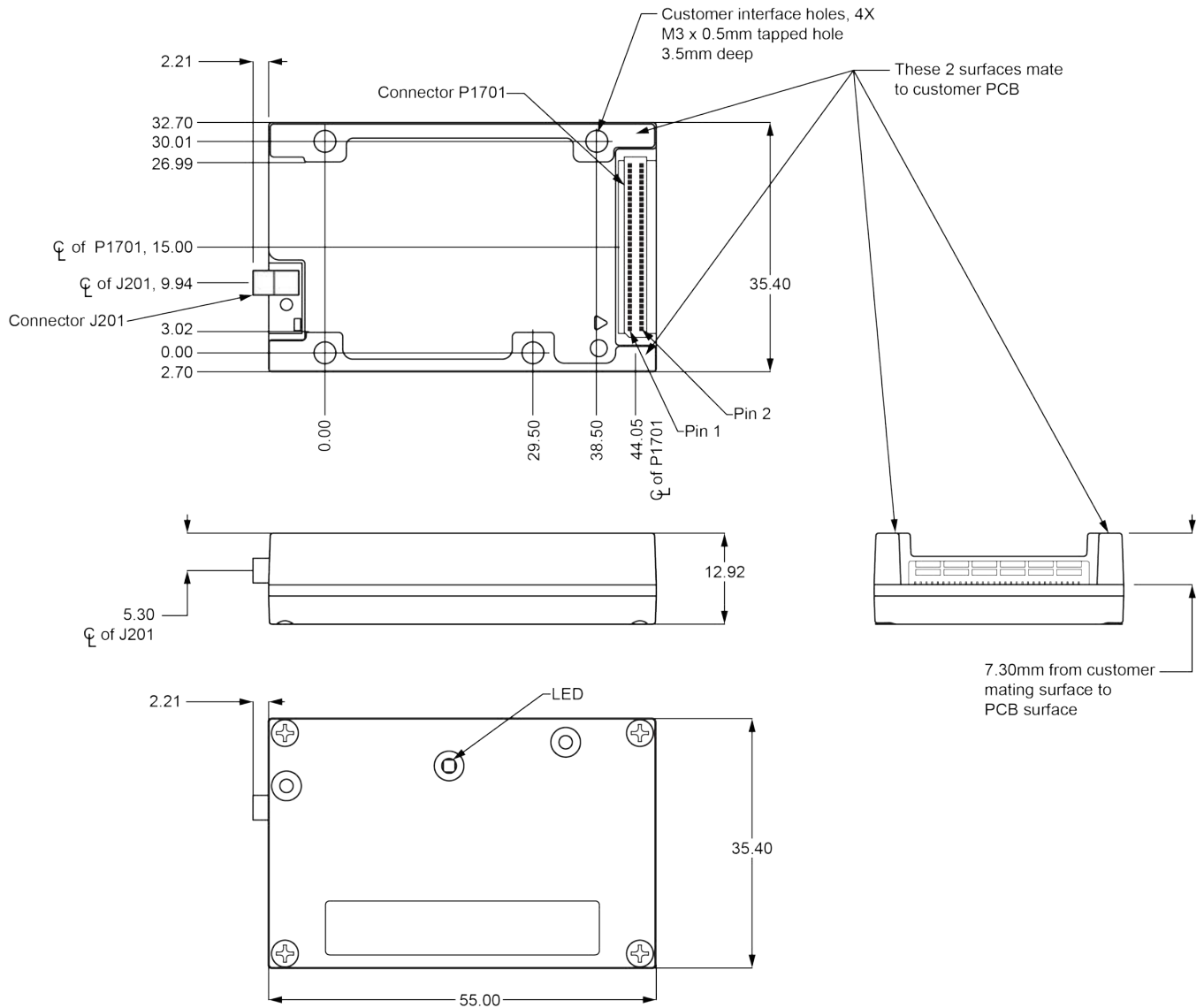
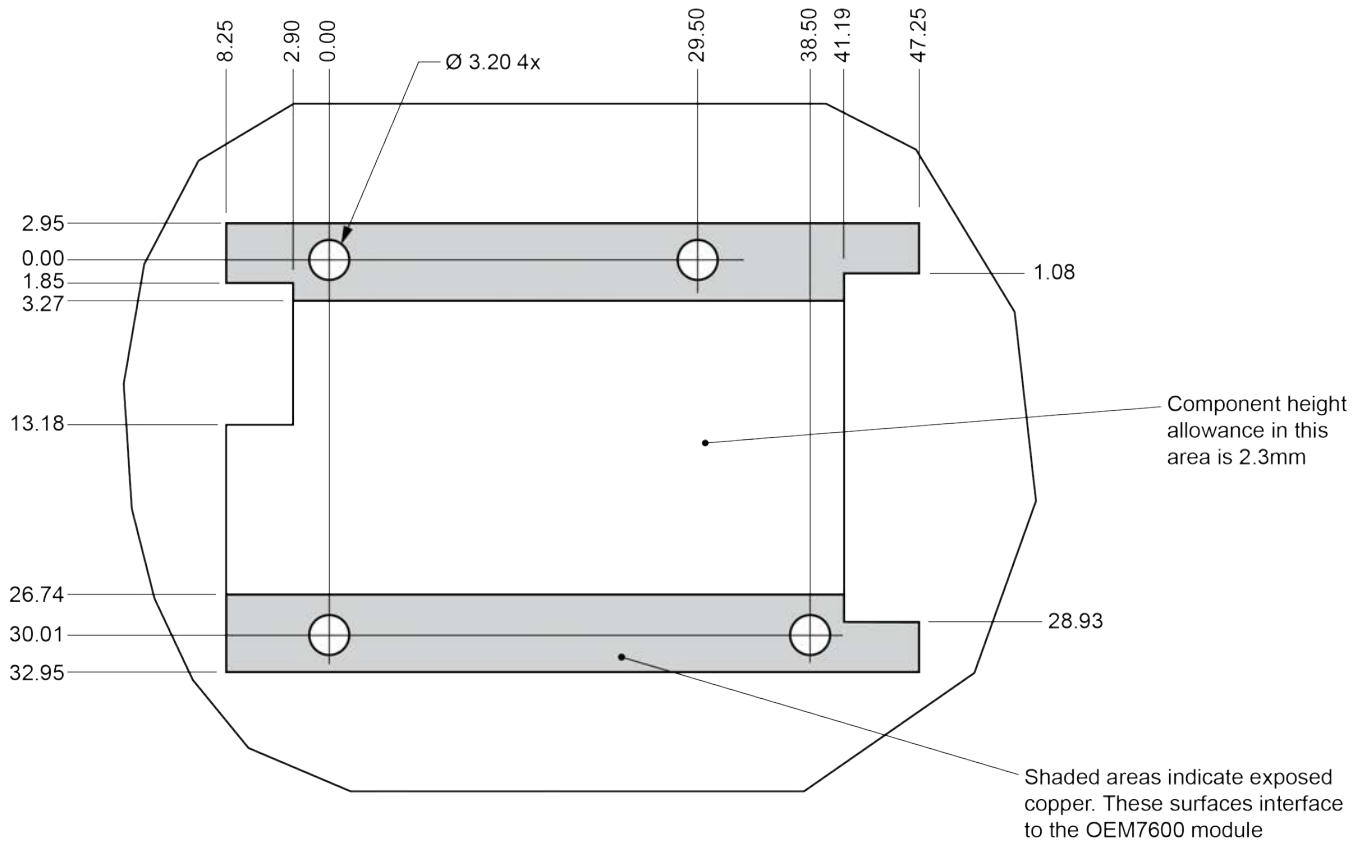

Figure 53: OEM7600 Interface Board Details



For information about the recommended mating connector, refer to *Table 2: OEM7 Communication and I/O Connectors* on page 40.

C.3 OEM7600 Electrical and Environmental Specifications

Table 32: OEM7600 Environmental Specifications

Operating Temperature	-40°C to +85°C
Storage Temperature	-55°C to +95°C
Humidity	95% non-condensing
Random Vibration	MIL-STD-810G (CH1), Method 514.7, Category 24 (20 g RMS)
Sinusoidal Vibration	IEC 60068-2-6
Bump	ISO 9022-31-06 (25 g)
Shock	
Operating	MIL-STD-810G (CH1), Method 516.7 (40 g)
Non-operating	MIL-STD-810G (CH1), Method 516.7 (75 g)
Acceleration	MIL-STD-810G (CH1), Method 513.7 (16 g)

Table 33: OEM7600 Power Requirements

Voltage	+3.3 VDC ±5%
Allowable Input Voltage Ripple	100 mV p-p maximum
Power Consumption	<p>0.9 W typical, GPS L1 only 1.3 W typical, GPS L1/L2, GLONASS L1/L2 1.8 W typical, all constellations, all frequencies, plus L-Band</p> <div style="border: 1px solid black; padding: 5px; margin-top: 10px;">  <p>These are typical values using serial ports without interference mitigation. These values can change with the number of satellites in view, firmware version, data logging rates and features in use. Use them as a guide for what you might expect but not as absolute values</p> </div>
Inrush Current	2.0 A for less than 1.8 ms (typical)

Table 34: OEM7600 RF Input/LNA Power Output

Antenna Connector	MMCX female, 50 Ω nominal impedance
-------------------	-------------------------------------

Cascaded antenna LNA gain (before receiver)	Firmware 7.04 and later	HDR disabled	+15 dB to +55 db, 26 dB typical
		HDR enabled	+20 dB to +55 db, 30 dB typical
	Firmware before 7.04	HDR disabled	+15 dB to +40 db, 26 dB typical
		HDR enabled	+20 dB to +40 db, 30 dB typical
RF Input Frequencies	GPS L1:	1575.42 MHz	
	GPS L2:	1227.60 MHz	
	GPS L5:	1176.45 MHz	
	GLONASS L1:	1593-1610 MHz	
	GLONASS L2:	1237-1254 MHz	
	GLONASS L3:	1202.025 MHz	
	Galileo E1: Galileo E5a: Galileo E5b: Galileo E5:	1575.42 MHz 1176.45 MHz 1207.14 MHz 1191.795 MHz	
BeiDou B1l: BeiDou B1C: BeiDou B2l: BeiDou B2a: BeiDou B2b:	1561.098 MHz 1575.42 MHz 1207.14 MHz 1176.45 MHz 1207.14 MHz		
L-Band:	1525 to 1560 MHz		
LNA Power	<p>+3.3 VDC \pm5%, 0 mA to 100 mA (supplied by card through center conductor of RF connector).</p> <p>LNA Power is generated from the 3.3 V supply input for the OEM7600.</p>		

C.4 OEM7600 Data Communication Specifications

Table 35: Data Communications Interface

COM1	
Electrical format	LVC MOS
Data rates ¹	2400, 4800, 9600 (default), 19200, 38400, 57600, 115200, 230400 or 460800 bit/s.
Signals supported	COM1_Tx, COM1_Rx, COM1_RTS, COM1_CTS
Electrostatic discharge protection	No
COM2	
Electrical format	LVC MOS
Data rates ¹	2400, 4800, 9600 (default), 19200, 38400, 57600, 115200, 230400 or 460800 bit/s.
Signals supported	COM2_Tx, COM2_Rx, COM2_RTS, COM2_CTS
Electrostatic discharge protection	No
COM3	
Electrical format	LVC MOS
Data rates ¹	2400, 4800, 9600 (default), 19200, 38400, 57600, 115200, 230400 or 460800 bit/s.
Signals supported	COM3_Tx, COM3_Rx
Electrostatic discharge protection	No
COM4	
Electrical format	LVC MOS
Data rates ¹	2400, 4800, 9600 (default), 19200, 38400, 57600, 115200, 230400 or 460800 bit/s.
Signals supported	COM4_Tx, COM4_Rx
Electrostatic discharge protection	No

¹Data rates higher than 115200 bit/s are not supported by standard PC hardware. Special PC hardware may be required for higher rates, including 230400 bit/s and 460800 bit/s.

COM5	
Electrical format	LVC MOS ¹
Data rates ¹	2400, 4800, 9600 (default), 19200, 38400, 57600, 115200, 230400 or 460800 bit/s.
Signals supported	COM5_Tx, COM5_Rx
Electrostatic discharge protection	No
CAN Bus	
Electrical Format	LVC MOS
Data rates	1 Mbps maximum. CAN Bus throughput is determined by slowest device on the bus
Signals supported	CAN0 and CAN1
USB	
Electrical format	Conforms to USB 2.0
Data rates	Hi-speed (480 Mb/s)
Signals supported	USB0 D+, USB0 D- USB1 D+, USB1 D-
ETHERNET	
Physical layer	10BASE-T/100BASE-TX

¹Upon power-up, COM5 is enabled by default. COM5 is multiplexed with COM2 hardware flow control.

C.5 OEM7600 Strobe Specifications

Table 36: OEM7600 Strobes Description

Strobes	Input/Output	Factory Default	Comment
ERROR	Output	Active high	Normally low. A high output on this pin indicates that the receiver is in an error state. For information about the cause of the error, log the RXSTATUS log.
EVENT_IN1 EVENT_IN2 EVENT_IN3 EVENT_IN4	Input Leading edge triggered	Active low	Input marks for which a pulse greater than 150 ns triggers certain logs to be generated. (Refer to the MARKxPOS and MARKxTIME logs and ONMARK trigger.) Polarity is configurable using the EVENTINCONTROL command.
EVENT_OUT1 EVENT_OUT2 EVENT_OUT3 EVENT_OUT4	Output	Active low	Programmable variable frequency outputs ranging from 0 Hz to 50 MHz (refer to the EVENTOUTCONTROL command).
ME_RDY	Output	Active high	Indicates to the host system that the receiver is ready to receive commands. This signal is not asserted while booting or during a reset. <div style="border: 1px solid black; padding: 5px; margin-top: 10px;">  If an error is detected during receiver operation (for example, an over temperature condition), the ERROR signal is asserted and the ME_RDY signal will normally remain asserted: commands can still be sent to the receiver under these conditions. At the time ERROR is asserted, POS_VALID signal is changed to not asserted. In the rare case of a fatal, unrecoverable error that leads to a reboot of the receiver, ME_RDY, ERROR and POS_VALID are all not asserted while the receiver restarts. </div>
POS_Valid (Position Valid)	Output	Active high	Indicates a valid GNSS position solution is available.

Strobes	Input/Output	Factory Default	Comment
nRESET_IN	Input	Active low	<p>Reset signal input from external system; active low.</p> <p>This pin must be held low for >20 μs while stable power is already applied, to reset the OEM7600 card.</p> <p>It is recommended to hold the nRESET_IN pin low for a >150 ms when initially applying power to the card, giving the power supply time to stabilize before the card starts to boot.</p>
PPS	Output	Active low	<p>A time synchronization output. This is a pulse where the leading edge is synchronized to receiver calculated GNSS Time. The polarity, period and pulse width can be configured using the PPSCONTROL command</p>

Table 37: OEM7600 Strobe Electrical Specifications

Strobe	Sym	Min (V)	Max (V)	Current (mA)
ERROR	V _{OL}		0.2	8
	V _{OH}	3.1		
EVENT_IN1 (Mark)	V _{IL}		0.8	-
EVENT_IN2 (Mark2)				
EVENT_IN3 (Mark3)	V _{IH}	1.7		
EVENT_IN4 (Mark4)				
EVENT_OUT1	V _{OL}		0.2	8
EVENT_OUT2				
EVENT_OUT3	V _{OH}	3.1		
EVENT_OUT4				
ME_RDY	V _{OL}		0.2	4
	V _{OH}	3.1		
POS_VALID	V _{OL}		0.55	8
	V _{OH}	2.3		
nRESET_IN	V _{IL}		0.8	-
	V _{IH}	2.55		
PPS	V _{OL}		0.55	24
	V _{OH}	2.3		

C.6 OEM7600 Interface Connector

C.6.1 P2001 Main Connector 60-Pin Socket

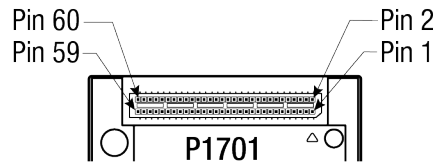

For information about the recommended mating connector, refer to *Table 2: OEM7 Communication and I/O Connectors* on page 40.

Pin	Signal Name	Signal Type	Signal Direction	V _{IL} Max (V)	V _{IH} Min (V)	V _{OL} Max (V)	V _{OH} Min (V)	Drive (mA)	Description
1	3V3	Power	Input	-	-	-	-	-	3.3 V ±5% supply input
2	3V3	Power	Input	-	-	-	-	-	3.3 V ±5% supply input
3	COM2_TXD	3.3V CMOS	Output	-	-	0.2	3.1	4	COM2 Transmit Data (UART)
4	COM1_TXD	3.3V CMOS	Output	-	-	0.55	2.3	24	COM1 Transmit Data (UART)
5	COM5_TXD/ COM2_RTS	3.3V CMOS	Output	-	-	0.2	3.1	4	This pin is internally multiplexed. COM5_TXD is the default. COM5_TXD: COM5 Transmit Data (UART). COM2_RTS: COM2 Request to Send Optional hardware flow control signal for the COM2 serial port.
6	COM1_RTS	3.3V CMOS	Output	-	-	0.2	3.1	4	COM1 Request to Send Optional hardware flow control signal for the COM1 serial port.
7	GND	Ground	-	-	-	-	-	-	Ground reference
8	GND	Ground	-	-	-	-	-	-	Ground reference
9	COM2_RXD	3.3V CMOS	Input	0.8	1.7	-	-	-	COM2 Receive Data (UART)

Pin	Signal Name	Signal Type	Signal Direction	V _{IL} Max (V)	V _{IH} Min (V)	V _{OL} Max (V)	V _{OH} Min (V)	Drive (mA)	Description
10	COM1_RXD	3.3V CMOS	Input	0.8	1.7	-	-	-	COM1 Receive Data (UART)
11	COM5_RXD/ COM2_CTS	3.3V CMOS	Input	0.8	1.7	-	-	-	This pin is internally multiplexed. COM5_RXD is the default. COM5_RXD: COM5 Receive Data (UART). COM2_CTS: COM2 Clear to Send Optional hardware flow control signal for the COM2 serial port.
12	COM1_CTS	3.3V CMOS	Input	0.8	1.7	-	-	-	COM1 Clear To Send Optional hardware flow control signals for the COM1 serial port.
13	COM4_RXD	3.3V CMOS	Input	0.8	1.7	-	-	-	COM4 Receive Data (UART)
14	COM3_RXD	3.3V CMOS	Input	0.8	1.7	-	-	-	COM3 Receive Data (UART)
15	STATUS_GREEN	3.3V CMOS	Output	-	-	0.2	3.1	4	Used to indicate the state of the receiver or provide error codes. These outputs provide the same information as the Status Indicator LED (see <i>Status LED</i> on page 88). STATUS_GREEN high and STATUS_RED low represents a Green LED.
16	STATUS_RED	3.3V CMOS	Output	-	-	0.2	3.1	4	STATUS_GREEN high and STATUS_RED high represents a Yellow LED. STATUS_GREEN low and STATUS_RED high represents a Red LED.

Pin	Signal Name	Signal Type	Signal Direction	V _{IL} Max (V)	V _{IH} Min (V)	V _{OL} Max (V)	V _{OH} Min (V)	Drive (mA)	Description
17	EVENT_OUT1	3.3V CMOS	Output	-	-	0.2	3.1	8	EVENT1 (Mark1) Output Rising edge triggered. Outputs a user-specified timing signal. Can be synchronized with PPS. Supports Variable Frequency Output function.
18	ME_RDY	3.3V CMOS	Output	-	-	0.2	3.1	4	Receiver Ready (Active High) Indicates to the host system that the receiver is ready to receive commands. This signal is not asserted while booting or during a reset. Internal 2.2 kΩ pull down.
19	COM4_TXD	3.3V CMOS	Output	-	-	0.2	3.1	4	COM4 Transmit Data (UART)
20	COM3_TXD	3.3V CMOS	Output	-	-	0.2	3.1	4	COM3 Transmit Data (UART)
21	ERROR	3.3V CMOS	Output	-	-	0.2	3.1	4	Error Indicator (Active High) Normally low. A high output on this pin indicates that the receiver is in an error state. Internal 2.2 kΩ pull down.
22	POS_VALID	3.3V CMOS	Output	-	-	0.2	3.1	4	Position Valid Output (Active High) A high output on this pin indicates that the receiver has computed a valid GNSS position. Internal 10 kΩ pull down.

Pin	Signal Name	Signal Type	Signal Direction	V _{IL} Max (V)	V _{IH} Min (V)	V _{OL} Max (V)	V _{OH} Min (V)	Drive (mA)	Description
23	EVENT_OUT3	3.3V CMOS	Output	-	-	0.2	3.1	8	EVENT3 (Mark3) Output Rising edge triggered. Outputs a user-specified timing signal. Can be synchronized with PPS. Supports Variable Frequency Output function.
24	PPS	3.3V CMOS	Output	-	-	0.55	2.3	24	Pulse Per Second output This signal defaults to one pulse per second but may be altered across a wide range of frequencies using software commands. Edges can be synchronized to GNSS time reference.
25	EVENT_OUT4	3.3V CMOS	Output	-	-	0.2	3.1	8	EVENT4 (Mark4) Output Rising edge triggered. Outputs a user-specified timing signal. Can be synchronized with PPS. Supports Variable Frequency Output function.
26	EVENT_OUT2	3.3V CMOS	Output	-	-	0.2	3.1	8	EVENT2 (Mark2) Output Rising edge triggered. Outputs a user-specified timing signal. Can be synchronized with PPS. Supports Variable Frequency Output function.
27	GND	Ground	-	-	-	-	-	-	Ground reference
28	GND	Ground	-	-	-	-	-	-	Ground reference

Pin	Signal Name	Signal Type	Signal Direction	V _{IL} Max (V)	V _{IH} Min (V)	V _{OL} Max (V)	V _{OH} Min (V)	Drive (mA)	Description
29	EVENT_IN2	3.3V CMOS	Input	0.8	1.7	-	-	-	EVENT2 (Mark2) input Rising or falling edge triggered. This input is used to provide a position or time data log based on an external trigger. Internal 10 kΩ pull up.
30	EVENT_IN1	3.3V CMOS	Input	0.8	1.7	-	-	-	EVENT1 (Mark1) input Rising or falling edge triggered. This input is used to provide a position or time data log based on an external trigger. Internal 10 kΩ pull up.
31	EVENT_IN4	3.3V CMOS	Input	0.8	1.7	-	-	-	EVENT4 (Mark4) input Rising or falling edge triggered. This input is used to provide a position or time data log based on an external trigger. Internal 10 kΩ pull up.
32	EVENT_IN3	3.3V CMOS	Input	0.8	1.7	-	-	-	EVENT3 (Mark3) input Rising or falling edge triggered. This input is used to provide a position or time data log based on an external trigger. Internal 10 kΩ pull up.
33	GND	Ground	-	-	-	-	-	-	Ground reference
34	GND	Ground	-	-	-	-	-	-	Ground reference
35	CAN1_RXD	3.3V CMOS	Input	0.8	1.7	-	-	-	CAN1 Receive Data This is a CMOS-level signal, requiring an external CAN transceiver.

Pin	Signal Name	Signal Type	Signal Direction	V _{IL} Max (V)	V _{IH} Min (V)	V _{OL} Max (V)	V _{OH} Min (V)	Drive (mA)	Description
36	CAN0_TXD	3.3V CMOS	Output	-	-	0.2	3.1	4	CAN0 Transmit Data This is a CMOS-level signal, requiring an external CAN transceiver.
37	CAN1_TXD	3.3V CMOS	Output	-	-	0.2	3.1	4	CAN1 Transmit Data This is a CMOS-level signal, requiring an external CAN transceiver.
38	CAN0_RXD	3.3V CMOS	Input	0.8	1.7	-	-	-	CAN0 Receive Data This is a CMOS-level signal, requiring an external CAN transceiver.
39	I2C_SDA	3.3V CMOS Open drain	I/O	0.7	2.0	0.4	2.9	-	I2C data line Open drain signal with internal 2.2 kΩ pull up to 3.3 V
40	I2C_SCL	3.3V CMOS Open drain	Output	-	-	0.4	3.1	-	I2C clock line Open drain signal with internal 2.2 kΩ pull up to 3.3 V
41	SPI_MOSI	3.3V CMOS	Output	-	-	0.2	3.1	4	Serial Peripheral Interface Master Output/Slave Input
42	SPI_nCS	3.3V CMOS	Output	-	-	0.2	3.1	4	Serial Peripheral Interface Chip Select (Active Low)
43	SPI_MISO	3.3V CMOS	Input	0.8	1.7	-	-	-	Serial Peripheral Interface Master Input/Slave Output
44	SPI_SCLK	3.3V CMOS	Output	-	-	0.2	3.1	4	Serial Peripheral Interface Serial Clock
45	GND	Ground	-	-	-	-	-	-	Ground reference
46	GND	Ground	-	-	-	-	-	-	Ground reference

Pin	Signal Name	Signal Type	Signal Direction	V _{IL} Max (V)	V _{IH} Min (V)	V _{OL} Max (V)	V _{OH} Min (V)	Drive (mA)	Description
47	USB1_D-	Analog	I/O	-	-	-	-	-	USB1 signal. This is one half of the USB1 differential pair. USB1_D+ and USB1_D- must be length-matched and routed as a 90 Ω differential pair.
48	USB0_D+	Analog	I/O	-	-	-	-	-	USB0 signal. This is one half of the USB0 differential pair. USB0_D+ and USB0_D- must be length-matched and routed as a 90 Ω differential pair.
49	USB1_D+	Analog	I/O	-	-	-	-	-	USB1 signal. This is one half of the USB1 differential pair. USB1_D+ and USB1_D- must be length-matched and routed as a 90 Ω differential pair.
50	USB0_D-	Analog	I/O	-	-	-	-	-	USB0 signal. This is one half of the USB0 differential pair. USB0_D+ and USB0_D- must be length-matched and routed as a 90 Ω differential pair.
51	UID	3.3V CMOS	Input	-	-	-	-	-	USB Port Mode Select. Leave this pin floating to put USB0 into Device mode and USB1 into Host mode. Tie this pin to GND to put USB0 into Host mode and USB1 into Device mode. Internal 10 kΩ pull up

Pin	Signal Name	Signal Type	Signal Direction	V _{IL} Max (V)	V _{IH} Min (V)	V _{OL} Max (V)	V _{OH} Min (V)	Drive (mA)	Description
52	USB0_VBUS	Power	I/O	3.3	5.25	-	-	-	<p>When the USB port mode is set to Host, this pin is an output.</p> <p>When the USB port mode is set to Device, this pin is an input.</p> <p>Host or Device mode is set using the USB_Port_Mode_Select pin (Pin 51).</p> <p>When an input, requires a voltage between 3.3 V and 5.25 V.</p> <p>When an output, provides 5 V for hosted devices</p> <p>USB0_VBUS is capable of providing up to 200 mA to a hosted USB device. Devices that require more than 200 mA must be powered separately.</p>
53	nRESET_IN	3.3V CMOS	Input	0.8	2.55	-	-	-	<p>Reset Input (Active Low)</p> <p>Resets the OEM7600 receiver card. This pin must be held low for >20 μs while stable power is already applied, to reset the OEM7600 card.</p> <p>It is recommended to hold the nRESET_IN pin low for a >150 ms when initially applying power to the card, giving the power supply time to stabilize before the card starts to boot.</p> <p>Internal 10 kΩ pullup.</p>
54	GND	Ground	-	-	-	-	-	-	Ground reference

Pin	Signal Name	Signal Type	Signal Direction	V _{IL} Max (V)	V _{IH} Min (V)	V _{OL} Max (V)	V _{OH} Min (V)	Drive (mA)	Description
55	ETH_LINK_ACT	3.3V CMOS	Output	-	-	0.2	3.1	8	<p>Ethernet Link and Activity LED indicator. Polarity of the indicator signal is low. When there is an active link, the pin is low. When there is activity on the link, the pin outputs a blink signal.</p> <div style="border: 1px solid black; padding: 5px; width: fit-content;">  <p>Do not use ETH_BIAS to supply the LED.</p> </div>
56	ETH_BIAS	Power	Output	-	-	-	-	-	<p>DC Bias source for the Ethernet magnetics. Do not use ETH_BIAS to supply any other circuitry.</p>
57	ETH_RX+	Analog	Input	-	-	-	-	-	<p>Ethernet Receive One half of the Ethernet receive differential pair. ETH_RX+ and ETH_RX- must be routed as a 100 Ω differential pair.</p>
58	ETH_TX+	Analog	Output	-	-	-	-	-	<p>Ethernet Transmit One half of the Ethernet transmit differential pair. ETH_TX+ and ETH_TX- must be routed as a 100 Ω differential pair.</p>
59	ETH_RX-	Analog	Input	-	-	-	-	-	<p>Ethernet Receive One half of the Ethernet receive differential pair. ETH_RX+ and ETH_RX- must be routed as a 100 Ω differential pair.</p>

Pin	Signal Name	Signal Type	Signal Direction	V _{IL} Max (V)	V _{IH} Min (V)	V _{OL} Max (V)	V _{OH} Min (V)	Drive (mA)	Description
60	ETH_TX-	Analog	Output	-	-	-	-	-	Ethernet Transmit One half of the Ethernet transmit differential pair. ETH_TX+ and ETH_TX- must be routed as a 100 Ω differential pair.

APPENDIX D OEM7700 Technical Specifications

Table 38: OEM7700 Physical Description

Size	46 mm x 71 mm x 8 mm
Weight	31 grams
NovAtel Part Number	Generic assembly OEM7700 01019525

See the following sections for more information about the OEM7700:

- *OEM7700 Performance Specifications* on the next page
- *OEM7700 Mechanical Specifications* on page 198
- *OEM7700 Electrical and Environmental Specifications* on page 201
- *OEM7700 Data Communication Specifications* on page 203
- *OEM7700 Strobe Specifications* on page 205
- *OEM7700 Interface Connector* on page 207

D.1 OEM7700 Performance Specifications

All specifications subject to GNSS system characteristics.

Table 39: OEM7700 Receiver Performance

Position Accuracy ¹	Single point L1	1.5 m RMS
	Single point L1/L2	1.2 m RMS
	SBAS ²	60 cm RMS
	DGPS	40 cm RMS
	TerraStar-L ^{3, 4}	40 cm RMS
	TerraStar-C PRO ^{3, 4}	2.5 cm RMS
	TerraStar-X ^{3, 4}	2.0 cm RMS
	RTK	1 cm + 1 ppm RMS
Signals Tracked	GPS	L1 C/A, L1C, L2C, L2P, L5
	GLONASS	L1 C/A, L2 C/A, L2P, L3
	BeiDou	B1I, B1C, B2I, B2a, B2b, B3I
	Galileo	E1, E5 AltBOC, E5a, E5b, E6
	NavIC (IRNSS)	L5
	QZSS	L1 C/A, L1C, L1S, L2C, L5, L6
	SBAS	L1, L5
	L-Band ⁵	Up to 5 channels
Time to First Fix	Hot: <20 s (Almanac and recent ephemeris saved and approximate position and time entered)	
	Cold: <39 s (No almanac or ephemeris and no approximate position or time)	

¹Typical values. All position and velocity RMS values are based on Horizontal position accuracy. Performance specifications are subject to GNSS system characteristics, Signal-in-Space (SIS) operational degradation, ionospheric and tropospheric conditions, satellite geometry, baseline length, multipath effects and the presence of intentional or unintentional interference sources.

²GPS-only.

³Requires a TerraStar subscription which is available direct from NovAtel novatel.com/products/gps-gnss-correction-services/terraStar-correction-services.

⁴Performance dependent on local observing conditions.

⁵Currently the receiver can track up to 3 L-Band channels.

Signal Reacquisition	<0.5 s L1 (typical) <1.0 s L2 and L5 (typical)			
Data Rates	Measurements	up to 100 Hz		
	Position	up to 100 Hz		
Time Accuracy ¹	20 ns RMS			
Velocity Accuracy	<0.03 m/s RMS			
Measurement Precision ²		Code	Carrier	
	GPS	L1 C/A	4 cm	0.5 mm
		L2 P(Y)	8 cm	1.0 mm
		L2C	8 cm	0.5 mm
		L5	3 cm	0.5 mm
	GLONASS	L1 C/A	8 cm	1.0 mm
		L2 P	8 cm	1.0 mm
		L2 C/A	8 cm	1.0 mm
	Galileo	E1	3 cm	0.5 mm
		E5a	3 cm	0.75 mm
		E5b	3 cm	0.75 mm
		E5 AltBOC	3 cm	0.75 mm
		E6	3 cm	0.75 mm
	BeiDou	B1I	4 cm	0.5 mm
		B1C	3 cm	0.5 mm
		B2I	4 cm	0.5 mm
		B2a	3 cm	0.5 mm
		B2b ³	3 cm	0.5 mm
B3I		4 cm	0.5 mm	
Velocity Limit ⁴	515 m/s			

¹Time accuracy does not include biases due to RF or antenna delay.

²Measurement precision should be compared with measurements using the same correlator spacing.

³Under good CN0 conditions, e.g. 44 dBHz.

⁴Export licensing restricts operation to a maximum of 515 metres per second, message output impacted above 500 m/s.

D.2 OEM7700 Mechanical Specifications

- Figure 54: OEM7700 Dimensions below
- Figure 55: OEM7700 Keep-outs on the next page
- Figure 56: OEM7700 Mounting Surfaces on page 200

Figure 54: OEM7700 Dimensions

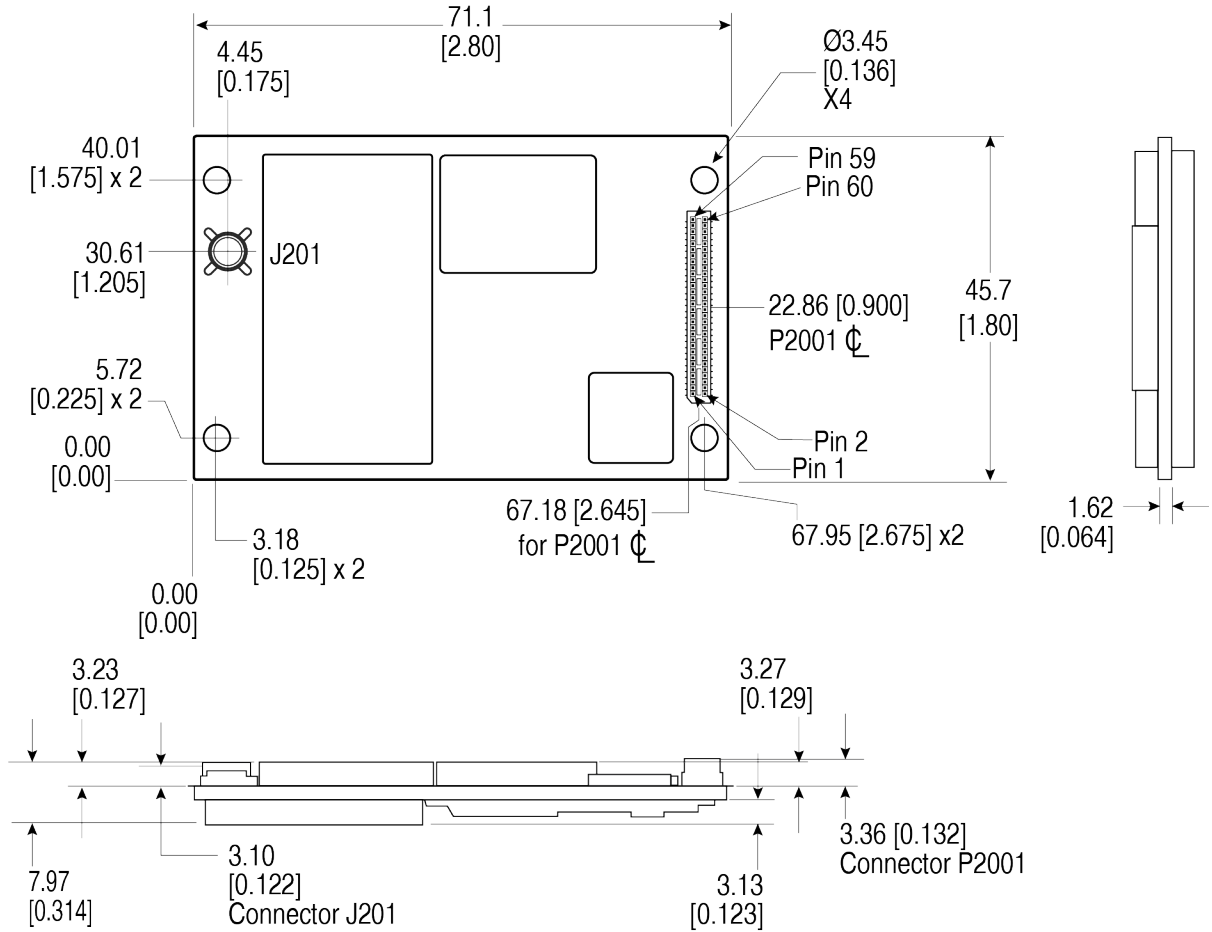

Notes: OEM7700

Dimensions are in millimetres [inches].

Connectors:

(a) J201 Huber + Shuhner 82_MMBX-S50-0-1/111 NE or 82_MMBX-0-1/111 NH or 82_MMBX-S50-0-1/111 NM

(b) P2001 Samtec ASP-189258-01

Figure 55: OEM7700 Keep-outs

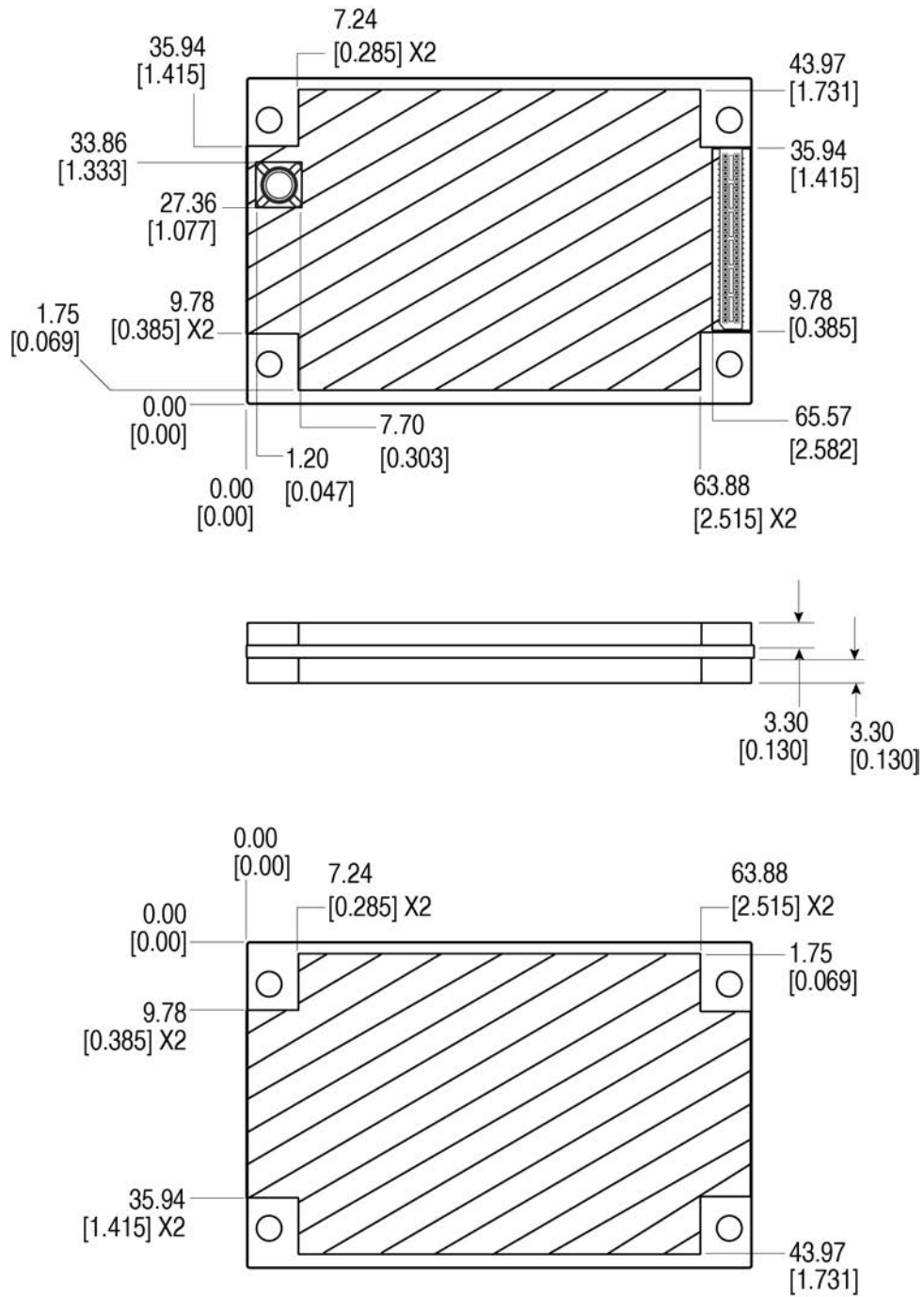

Dimensions are in millimetres [inches].

Figure 56: OEM7700 Mounting Surfaces

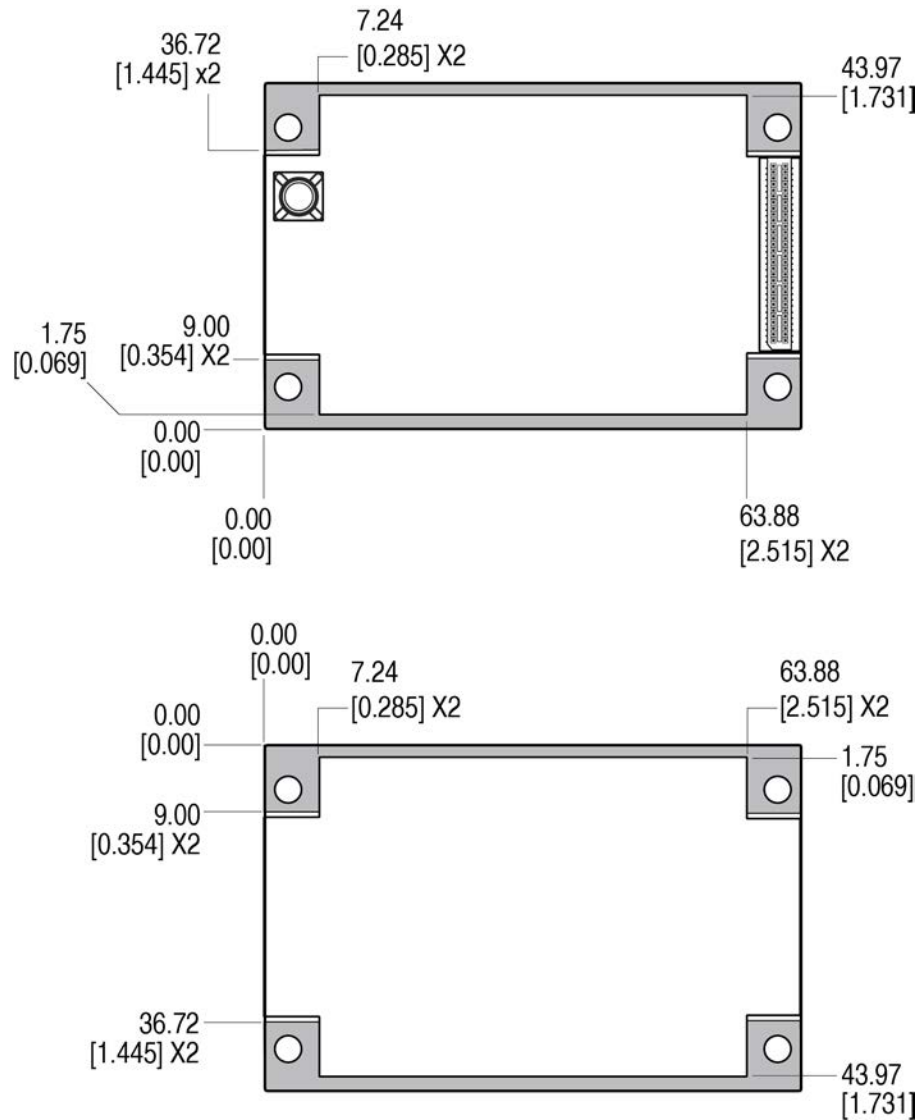

Dimensions are in millimetres [inches].

The mounting surfaces are shown in gray.

These mounting surfaces are designed to work with mounting rails. For information about mounting the OEM7700, refer to *Mounting the Printed Circuit Board* on page 31.



Assembly tolerances must be considered when using mounting rail features.



For information about the recommended mating connector, refer to *Table 2: OEM7 Communication and I/O Connectors* on page 40.

D.3 OEM7700 Electrical and Environmental Specifications

Table 40: OEM7700 Environmental Specifications

Operating Temperature	-40°C to +85°C
Storage Temperature	-55°C to +95°C
Humidity	95% non-condensing
Random Vibration	MIL-STD-810G, Method 514.6, Category 24 (20 g RMS) ¹
Sinusoidal Vibration	IEC 60068-2-6
Bump	ISO 9022-31-06 (25 g)
Shock	
Operating	MIL-STD-810G, Method 516.6 (40 g)
Non-operating	MIL-STD-810G, Method 516.6 (75 g)
Acceleration	MIL-STD-810G, Method 513.7 (16 g)

Table 41: OEM7700 Power Requirements

Voltage	+3.3 VDC ±5%
Allowable Input Voltage Ripple	100 mV p-p maximum
Power Consumption	<p>0.9 W typical, GPS L1 only 1.3 W typical, GPS L1/L2, GLONASS L1/L2 1.8 W typical, all constellations, all frequencies, plus L-Band</p> <div style="border: 1px solid black; padding: 5px; margin-top: 10px;">  <p>These are typical values using serial ports without interference mitigation. These values can change with the number of satellites in view, firmware version, data logging rates and features in use. Use them as a guide for what you might expect but not as absolute values</p> </div>
Inrush Current	2.0 A for less than 1.8 ms (typical)

Table 42: OEM7700 RF Input/LNA Power Output

Antenna Connector	MMBX female, 50 Ω nominal impedance
-------------------	-------------------------------------

¹Requires mechanical mounting rails to meet 20 g; meets 7.7 g without rails.

Cascaded antenna LNA gain (before receiver)	Firmware 7.04 and later	HDR disabled	+15 dB to +55 db, 26 dB typical
		HDR enabled	+20 dB to +55 db, 30 dB typical
	Firmware before 7.04	HDR disabled	+15 dB to +40 db, 26 dB typical
		HDR enabled	+20 dB to +40 db, 30 dB typical
RF Input Frequencies	GPS L1:	1575.42 MHz	
	GPS L2:	1227.60 MHz	
	GPS L5:	1176.45 MHz	
	GLONASS L1:	1593-1610 MHz	
	GLONASS L2:	1237-1254 MHz	
	GLONASS L3:	1202.025 MHz	
	Galileo E1:	1575.42 MHz	
Galileo E5a:	1176.45 MHz		
Galileo E5b:	1207.14 MHz		
Galileo E5:	1191.795 MHz		
Galileo E6:	1278.75 MHz		
BeiDou B1I:	1561.098 MHz		
	BeiDou B1C:	1575.42 MHz	
	BeiDou B2I:	1207.14 MHz	
	BeiDou B2a:	1176.45 MHz	
	BeiDou B2b	1207.14 MHz	
	BeiDou B3I:	1268.52 MHz	
L-Band:	1545 to 1560 MHz ¹		
LNA Power	<p>+5.0 VDC \pm5%, 0 mA to 200 mA (supplied by card through center conductor of RF connector).</p> <p>LNA Power is generated from the 3.3 V supply input for the OEM7700.</p>		

¹For hardware releases 1.10 and later. For earlier hardware versions, the L-Band RF Input Frequency is 1525 to 1560 MHz.

D.4 OEM7700 Data Communication Specifications

Table 43: Data Communications Interface

COM1	
Electrical format	LVC MOS
Data rates ¹	2400, 4800, 9600 (default), 19200, 38400, 57600, 115200, 230400 or 460800 bit/s.
Signals supported	COM1_Tx, COM1_Rx, COM1_RTS, COM1_CTS
Electrostatic discharge protection	No
COM2	
Electrical format	LVC MOS
Data rates ¹	2400, 4800, 9600 (default), 19200, 38400, 57600, 115200, 230400 or 460800 bit/s.
Signals supported	COM2_Tx, COM2_Rx, COM2_RTS, COM2_CTS
Electrostatic discharge protection	No
COM3	
Electrical format	LVC MOS
Data rates ¹	2400, 4800, 9600 (default), 19200, 38400, 57600, 115200, 230400 or 460800 bit/s.
Signals supported	COM3_Tx, COM3_Rx
Electrostatic discharge protection	No
COM4	
Electrical format	LVC MOS
Data rates ¹	2400, 4800, 9600 (default), 19200, 38400, 57600, 115200, 230400 or 460800 bit/s.
Signals supported	COM4_Tx, COM4_Rx
Electrostatic discharge protection	No

¹Data rates higher than 115200 bit/s are not supported by standard PC hardware. Special PC hardware may be required for higher rates, including 230400 bit/s and 460800 bit/s.

COM5	
Electrical format	LVC MOS ¹
Data rates ¹	2400, 4800, 9600 (default), 19200, 38400, 57600, 115200, 230400 or 460800 bit/s.
Signals supported	COM5_Tx, COM5_Rx
Electrostatic discharge protection	No
CAN Bus	
Electrical Format	LVC MOS
Data rates	1 Mbps maximum. CAN Bus throughput is determined by slowest device on the bus
Signals supported	CAN0 and CAN1
USB	
Electrical format	Conforms to USB 2.0
Data rates	Hi-speed (480 Mb/s)
Signals supported	USB0 D+, USB0 D- USB1 D+, USB1 D-
ETHERNET	
Physical layer	10BASE-T/100BASE-TX

¹Upon power-up, COM5 is enabled by default. COM5 is multiplexed with COM2 hardware flow control.

D.5 OEM7700 Strobe Specifications

Table 44: OEM7700 Strobes Description

Strobes	Input/Output	Factory Default	Comment
ERROR	Output	Active high	Normally low. A high output on this pin indicates that the receiver is in an error state. For information about the cause of the error, log the RXSTATUS log.
EVENT_IN1 EVENT_IN2 EVENT_IN3 EVENT_IN4	Input Leading edge triggered	Active low	Input marks for which a pulse greater than 150 ns triggers certain logs to be generated. (Refer to the MARKxPOS and MARKxTIME logs and ONMARK trigger.) Polarity is configurable using the EVENTINCONTROL command.
EVENT_OUT1 EVENT_OUT2 EVENT_OUT3 EVENT_OUT4	Output	Active low	Programmable variable frequency outputs ranging from 0 Hz to 50 MHz (refer to the EVENTOUTCONTROL command).
ME_RDY	Output	Active high	Indicates to the host system that the receiver is ready to receive commands. This signal is not asserted while booting or during a reset. <div style="border: 1px solid black; padding: 5px; margin-top: 10px;">  If an error is detected during receiver operation (for example, an over temperature condition), the ERROR signal is asserted and the ME_RDY signal will normally remain asserted: commands can still be sent to the receiver under these conditions. At the time ERROR is asserted, POS_VALID signal is changed to not asserted. In the rare case of a fatal, unrecoverable error that leads to a reboot of the receiver, ME_RDY, ERROR and POS_VALID are all not asserted while the receiver restarts. </div>
POS_Valid (Position Valid)	Output	Active high	Indicates a valid GNSS position solution is available.

Strobes	Input/Output	Factory Default	Comment
nRESET_IN	Input	Active low	<p>Reset signal input from external system; active low.</p> <p>This pin must be held low for >20 μs while stable power is already applied, to reset the OEM7700 card.</p> <p>It is recommended to hold the nRESET_IN pin low for a >150 ms when initially applying power to the card, giving the power supply time to stabilize before the card starts to boot.</p>
PPS	Output	Active low	<p>A time synchronization output. This is a pulse where the leading edge is synchronized to receiver calculated GNSS Time. The polarity, period and pulse width can be configured using the PPSCONTROL command</p>

Table 45: OEM7700 Strobe Electrical Specifications

Strobe	Sym	Min (V)	Max (V)	Current (mA)
ERROR	V _{OL}		0.2	8
	V _{OH}	3.1		
EVENT_IN1 (Mark)	V _{IL}		0.8	-
EVENT_IN2 (Mark2)				
EVENT_IN3 (Mark3)	V _{IH}	1.7		-
EVENT_IN4 (Mark4)				
EVENT_OUT1	V _{OL}		0.2	8
EVENT_OUT2				
EVENT_OUT3	V _{OH}	3.1		8
EVENT_OUT4				
ME_RDY	V _{OL}		0.2	4
	V _{OH}	3.1		
POS_VALID	V _{OL}		0.55	8
	V _{OH}	2.3		
nRESET_IN	V _{IL}		0.8	-
	V _{IH}	2.55		
PPS	V _{OL}		0.55	24
	V _{OH}	2.3		

D.6 OEM7700 Interface Connector

D.6.1 P2001 Main Connector 60-Pin Socket

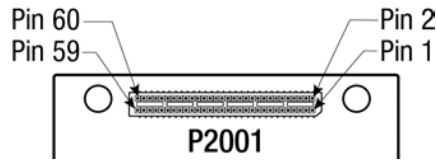

For information about the recommended mating connector, refer to *Table 2: OEM7 Communication and I/O Connectors* on page 40.

Pin	Signal Name	Signal Type	Signal Direction	V_{IL} Max (V)	V_{IH} Min (V)	V_{OL} Max (V)	V_{OH} Min (V)	Drive (mA)	Description
1	3V3	Power	Input	-	-	-	-	-	3.3 V \pm 5% supply input
2	3V3	Power	Input	-	-	-	-	-	3.3 V \pm 5% supply input
3	COM2_TXD	3.3V CMOS	Output	-	-	0.2	3.1	4	COM2 Transmit Data (UART)
4	COM1_TXD	3.3V CMOS	Output	-	-	0.55	2.3	24	COM1 Transmit Data (UART)
5	COM5_TXD/ COM2_RTS	3.3V CMOS	Output	-	-	0.2	3.1	4	This pin is internally multiplexed. COM5_TXD is the default. COM5_TXD: COM5 Transmit Data (UART). COM2_RTS: COM2 Request to Send Optional hardware flow control signal for the COM2 serial port.
6	COM1_RTS	3.3V CMOS	Output	-	-	0.2	3.1	4	COM1 Request to Send Optional hardware flow control signal for the COM1 serial port.
7	GND	Ground	-	-	-	-	-	-	Ground reference
8	GND	Ground	-	-	-	-	-	-	Ground reference
9	COM2_RXD	3.3V CMOS	Input	0.8	1.7	-	-	-	COM2 Receive Data (UART)

Pin	Signal Name	Signal Type	Signal Direction	V _{IL} Max (V)	V _{IH} Min (V)	V _{OL} Max (V)	V _{OH} Min (V)	Drive (mA)	Description
10	COM1_RXD	3.3V CMOS	Input	0.8	1.7	-	-	-	COM1 Receive Data (UART)
11	COM5_RXD/ COM2_CTS	3.3V CMOS	Input	0.8	1.7	-	-	-	This pin is internally multiplexed. COM5_RXD is the default. COM5_RXD: COM5 Receive Data (UART). COM2_CTS: COM2 Clear to Send Optional hardware flow control signal for the COM2 serial port.
12	COM1_CTS	3.3V CMOS	Input	0.8	1.7	-	-	-	COM1 Clear To Send Optional hardware flow control signals for the COM1 serial port.
13	COM4_RXD	3.3V CMOS	Input	0.8	1.7	-	-	-	COM4 Receive Data (UART)
14	COM3_RXD	3.3V CMOS	Input	0.8	1.7	-	-	-	COM3 Receive Data (UART)
15	STATUS_GREEN	3.3V CMOS	Output	-	-	0.2	3.1	4	Used to indicate the state of the receiver or provide error codes. These outputs provide the same information as the Status Indicator LED (see <i>Status LED</i> on page 88). STATUS_GREEN high and STATUS_RED low represents a Green LED.
16	STATUS_RED	3.3V CMOS	Output	-	-	0.2	3.1	4	STATUS_GREEN high and STATUS_RED high represents a Yellow LED. STATUS_GREEN low and STATUS_RED high represents a Red LED.

Pin	Signal Name	Signal Type	Signal Direction	V _{IL} Max (V)	V _{IH} Min (V)	V _{OL} Max (V)	V _{OH} Min (V)	Drive (mA)	Description
17	EVENT_OUT1	3.3V CMOS	Output	-	-	0.2	3.1	8	EVENT1 (Mark1) Output Rising edge triggered. Outputs a user-specified timing signal. Can be synchronized with PPS. Supports Variable Frequency Output function.
18	ME_RDY	3.3V CMOS	Output	-	-	0.2	3.1	4	Receiver Ready (Active High) Indicates to the host system that the receiver is ready to receive commands. This signal is not asserted while booting or during a reset. Internal 2.2 kΩ pull down.
19	COM4_TXD	3.3V CMOS	Output	-	-	0.2	3.1	4	COM4 Transmit Data (UART)
20	COM3_TXD	3.3V CMOS	Output	-	-	0.2	3.1	4	COM3 Transmit Data (UART)
21	ERROR	3.3V CMOS	Output	-	-	0.2	3.1	4	Error Indicator (Active High) Normally low. A high output on this pin indicates that the receiver is in an error state. Internal 2.2 kΩ pull down.
22	POS_VALID	3.3V CMOS	Output	-	-	0.2	3.1	4	Position Valid Output (Active High) A high output on this pin indicates that the receiver has computed a valid GNSS position. Internal 10 kΩ pull down.

Pin	Signal Name	Signal Type	Signal Direction	V _{IL} Max (V)	V _{IH} Min (V)	V _{OL} Max (V)	V _{OH} Min (V)	Drive (mA)	Description
23	EVENT_OUT3	3.3V CMOS	Output	-	-	0.2	3.1	8	EVENT3 (Mark3) Output Rising edge triggered. Outputs a user-specified timing signal. Can be synchronized with PPS. Supports Variable Frequency Output function.
24	PPS	3.3V CMOS	Output	-	-	0.55	2.3	24	Pulse Per Second output This signal defaults to one pulse per second but may be altered across a wide range of frequencies using software commands. Edges can be synchronized to GNSS time reference.
25	EVENT_OUT4	3.3V CMOS	Output	-	-	0.2	3.1	8	EVENT4 (Mark4) Output Rising edge triggered. Outputs a user-specified timing signal. Can be synchronized with PPS. Supports Variable Frequency Output function.
26	EVENT_OUT2	3.3V CMOS	Output	-	-	0.2	3.1	8	EVENT2 (Mark2) Output Rising edge triggered. Outputs a user-specified timing signal. Can be synchronized with PPS. Supports Variable Frequency Output function.
27	GND	Ground	-	-	-	-	-	-	Ground reference
28	GND	Ground	-	-	-	-	-	-	Ground reference

Pin	Signal Name	Signal Type	Signal Direction	V _{IL} Max (V)	V _{IH} Min (V)	V _{OL} Max (V)	V _{OH} Min (V)	Drive (mA)	Description
29	EVENT_IN2	3.3V CMOS	Input	0.8	1.7	-	-	-	EVENT2 (Mark2) input Rising or falling edge triggered. This input is used to provide a position or time data log based on an external trigger. Internal 10 kΩ pull up.
30	EVENT_IN1	3.3V CMOS	Input	0.8	1.7	-	-	-	EVENT1 (Mark1) input Rising or falling edge triggered. This input is used to provide a position or time data log based on an external trigger. Internal 10 kΩ pull up.
31	EVENT_IN4	3.3V CMOS	Input	0.8	1.7	-	-	-	EVENT4 (Mark4) input Rising or falling edge triggered. This input is used to provide a position or time data log based on an external trigger. Internal 10 kΩ pull up.
32	EVENT_IN3	3.3V CMOS	Input	0.8	1.7	-	-	-	EVENT3 (Mark3) input Rising or falling edge triggered. This input is used to provide a position or time data log based on an external trigger. Internal 10 kΩ pull up.
33	GND	Ground	-	-	-	-	-	-	Ground reference
34	GND	Ground	-	-	-	-	-	-	Ground reference
35	CAN1_RXD	3.3V CMOS	Input	0.8	1.7	-	-	-	CAN1 Receive Data This is a CMOS-level signal, requiring an external CAN transceiver.

Pin	Signal Name	Signal Type	Signal Direction	V _{IL} Max (V)	V _{IH} Min (V)	V _{OL} Max (V)	V _{OH} Min (V)	Drive (mA)	Description
36	CAN0_TXD	3.3V CMOS	Output	-	-	0.2	3.1	4	CAN0 Transmit Data This is a CMOS-level signal, requiring an external CAN transceiver.
37	CAN1_TXD	3.3V CMOS	Output	-	-	0.2	3.1	4	CAN1 Transmit Data This is a CMOS-level signal, requiring an external CAN transceiver.
38	CAN0_RXD	3.3V CMOS	Input	0.8	1.7	-	-	-	CAN0 Receive Data This is a CMOS-level signal, requiring an external CAN transceiver.
39	I2C_SCA	3.3V CMOS Open drain	I/O	0.7	2.0	0.4	2.9	-	I2C data line Open drain signal with internal 2.2 kΩ pull up to 3.3 V
40	I2C_SCL	3.3V CMOS Open drain	Output-	-	-	0.4	3.1	-	I2C clock line Open drain signal with internal 2.2 kΩ pull up to 3.3 V
41	SPI_MOSI	3.3V CMOS	Output	-	-	0.2	3.1	4	Serial Peripheral Interface Master Output/Slave Input
42	SPI_nCS	3.3V CMOS	Output	-	-	0.2	3.1	4	Serial Peripheral Interface Chip Select (Active Low)
43	SPI_MISO	3.3V CMOS	Input	0.8	1.7	-	-	-	Serial Peripheral Interface Master Input/Slave Output
44	SPI_SCLK	3.3V CMOS	Output	-	-	0.2	3.1	4	Serial Peripheral Interface Serial Clock
45	GND	Ground	-	-	-	-	-	-	Ground reference
46	GND	Ground	-	-	-	-	-	-	Ground reference

Pin	Signal Name	Signal Type	Signal Direction	V _{IL} Max (V)	V _{IH} Min (V)	V _{OL} Max (V)	V _{OH} Min (V)	Drive (mA)	Description
47	USB1_D-	Analog	I/O	-	-	-	-	-	USB1 signal. This is one half of the USB1 differential pair. USB1_D+ and USB1_D- must be length-matched and routed as a 90 Ω differential pair.
48	USB0_D+	Analog	I/O	-	-	-	-	-	USB0 signal. This is one half of the USB0 differential pair. USB0_D+ and USB0_D- must be length-matched and routed as a 90 Ω differential pair.
49	USB1_D+	Analog	I/O	-	-	-	-	-	USB1 signal. This is one half of the USB1 differential pair. USB1_D+ and USB1_D- must be length-matched and routed as a 90 Ω differential pair.
50	USB0_D-	Analog	I/O	-	-	-	-	-	USB0 signal. This is one half of the USB0 differential pair. USB0_D+ and USB0_D- must be length-matched and routed as a 90 Ω differential pair.
51	UID	3.3V CMOS	Input	-	-	-	-	-	USB Port Mode Select. Leave this pin floating to put USB0 into Device mode and USB1 into Host mode. Tie this pin to GND to put USB0 into Host mode and USB1 into Device mode. Internal 10 kΩ pull up

Pin	Signal Name	Signal Type	Signal Direction	V _{IL} Max (V)	V _{IH} Min (V)	V _{OL} Max (V)	V _{OH} Min (V)	Drive (mA)	Description
52	USB0_VBUS	Power	I/O	3.3	5.25	-	-	-	<p>When the USB port mode is set to Host, this pin is an output.</p> <p>When the USB port mode is set to Device, this pin is an input.</p> <p>Host or Device mode is set using the USB_Port_Mode_Select pin (Pin 51).</p> <p>When an input, requires a voltage between 3.3 V and 5.25 V.</p> <p>When an output, provides 5 V for hosted devices</p> <p>USB0_VBUS is capable of providing up to 200 mA to a hosted USB device. Devices that require more than 200 mA must be powered separately.</p>
53	nRESET_IN	3.3V CMOS	Input	0.8	2.55	-	-	-	<p>Reset Input (Active Low)</p> <p>Resets the OEM7700 receiver card. This pin must be held low for >20 μs while stable power is already applied, to reset the OEM7700 card.</p> <p>It is recommended to hold the nRESET_IN pin low for a >150 ms when initially applying power to the card, giving the power supply time to stabilize before the card starts to boot.</p> <p>Internal 10 kΩ pullup.</p>
54	GND	Ground	-	-	-	-	-	-	Ground reference

Pin	Signal Name	Signal Type	Signal Direction	V _{IL} Max (V)	V _{IH} Min (V)	V _{OL} Max (V)	V _{OH} Min (V)	Drive (mA)	Description
55	ETH_LINK_ACT	3.3V CMOS	Output	-	-	0.2	3.1	8	<p>Ethernet Link and Activity LED indicator. Polarity of the indicator signal is low. When there is an active link, the pin is low. When there is activity on the link, the pin outputs a blink signal.</p> <div style="border: 1px solid black; padding: 5px; width: fit-content;">  Do not use ETH_BIAS to supply the LED. </div>
56	ETH_BIAS	Power	Output	-	-	-	-	-	<p>DC Bias source for the Ethernet magnetics. Do not use ETH_BIAS to supply any other circuitry.</p>
57	ETH_RX+	Analog	Input	-	-	-	-	-	<p>Ethernet Receive One half of the Ethernet receive differential pair. ETH_RX+ and ETH_RX- must be routed as a 100 Ω differential pair.</p>
58	ETH_TX+	Analog	Output	-	-	-	-	-	<p>Ethernet Transmit One half of the Ethernet transmit differential pair. ETH_TX+ and ETH_TX- must be routed as a 100 Ω differential pair.</p>
59	ETH_RX-	Analog	Input	-	-	-	-	-	<p>Ethernet Receive One half of the Ethernet receive differential pair. ETH_RX+ and ETH_RX- must be routed as a 100 Ω differential pair.</p>

Pin	Signal Name	Signal Type	Signal Direction	V _{IL} Max (V)	V _{IH} Min (V)	V _{OL} Max (V)	V _{OH} Min (V)	Drive (mA)	Description
60	ETH_TX-	Analog	Output	-	-	-	-	-	Ethernet Transmit One half of the Ethernet transmit differential pair. ETH_TX+ and ETH_TX- must be routed as a 100 Ω differential pair.

APPENDIX E OEM7720 Technical Specifications

Table 46: OEM7720 Physical Description

Size	46 mm x 71 mm x 7.5 mm
Weight	29 grams
NovAtel Part Number	Generic Assembly OEM7720 01019906

See the following sections for more information about the OEM7720:

- *OEM7720 Performance Specifications* on the next page
- *OEM7720 Mechanical Specifications* on page 221
- *OEM7720 Electrical and Environmental Specifications* on page 224
- *OEM7720 Data Communication Specifications* on page 226
- *OEM7720 Strobe Specifications* on page 228
- *OEM7720 Interface Connector* on page 230

E.1 OEM7720 Performance Specifications

All specifications subject to GNSS system characteristics.

Table 47: OEM7720 Receiver Performance

Position Accuracy ¹	Single point L1	1.5 m RMS
	Single point L1/L2	1.2 m RMS
	SBAS ²	60 cm RMS
	DGPS	40 cm RMS
	TerraStar-L ^{3, 4}	40 cm RMS
	TerraStar-C PRO ^{3, 4}	2.5 cm RMS
	TerraStar-X ^{3, 4}	2.0 cm RMS
	RTK	1 cm + 1 ppm RMS
Signals Tracked Primary Antenna	GPS	L1 C/A, L1C, L2C, L2P, L5
	GLONASS	L1 C/A, L2 C/A, L2P, L3
	BeiDou	B1I, B1C, B2I, B2a, B2b
	Galileo	E1, E5 AltBOC, E5a, E5b
	NavIC (IRNSS)	L5
	QZSS	L1 C/A, L1C, L1S, L2C, L5
	SBAS	L1, L5
	L-Band ⁵	Up to 5 channels

¹Typical values. All position and velocity RMS values are based on Horizontal position accuracy. Performance specifications are subject to GNSS system characteristics, Signal-in-Space (SIS) operational degradation, ionospheric and tropospheric conditions, satellite geometry, baseline length, multipath effects and the presence of intentional or unintentional interference sources.

²GPS-only.

³Requires a TerraStar subscription which is available direct from NovAtel novatel.com/products/gps-gnss-correction-services/terraStar-correction-services.

⁴Performance dependent on local observing conditions.

⁵Currently the receiver can track up to 3 L-Band channels.

Signals Tracked Secondary Antenna	GPS	L1 C/A, L1C, L2C, L2P, L5
	GLONASS	L1 C/A, L2 C/A, L2P, L3
	BeiDou	B1I, B1C, B2I, B2a, B2b
	Galileo	E1, E5 AltBOC, E5a, E5b
	NavIC (IRNSS)	L5
	QZSS	L1 C/A, L1C, L1S, L2C, L5
Time to First Fix	Hot: <20 s (Almanac and recent ephemeris saved and approximate position and time entered) Cold: <39 s (No almanac or ephemeris and no approximate position or time)	
Signal Reacquisition	<0.5 s L1 (typical) <1.0 s L2 and L5 (typical)	
Data Rates	Measurements	up to 100 Hz
	Position	up to 100 Hz
Time Accuracy ¹	20 ns RMS	
Velocity Accuracy	<0.03 m/s RMS	

¹Time accuracy does not include biases due to RF or antenna delay.

			Code	Carrier
	Measurement Precision ¹	GPS	L1 C/A	4 cm
L2 P(Y)			8 cm	1.0 mm
L2C			8 cm	0.5 mm
L5			3 cm	0.5 mm
GLONASS		L1 C/A	8 cm	1.0 mm
		L2 P	8 cm	1.0 mm
		L2 C/A	8 cm	1.0 mm
Galileo		E1	3 cm	0.5 mm
		E5a	3 cm	0.75 mm
		E5b	3 cm	0.75 mm
		E5 AltBOC	3 cm	0.75 mm
BeiDou		B1I	4 cm	0.5 mm
		B1C	3 cm	0.5 mm
		B2I	4 cm	0.5 mm
		B2a	3 cm	0.5 mm
		B2b ²	3 cm	0.5 mm
ALIGN Heading Accuracy		Baseline = 2 m	0.08 degrees	
	Baseline = 4 m	0.05 degrees		
Velocity Limit ³	515 m/s			

¹Measurement precision should be compared with measurements using the same correlator spacing.

²Under good CN0 conditions, e.g. 44 dBHz.

³Export licensing restricts operation to a maximum of 515 metres per second, message output impacted above 500 m/s.

E.2 OEM7720 Mechanical Specifications

- *Figure 57: OEM7720 Dimensions* below
- *Figure 58: OEM7720 Keep-outs* on the next page
- *Figure 59: OEM7720 Mounting Surfaces* on page 223

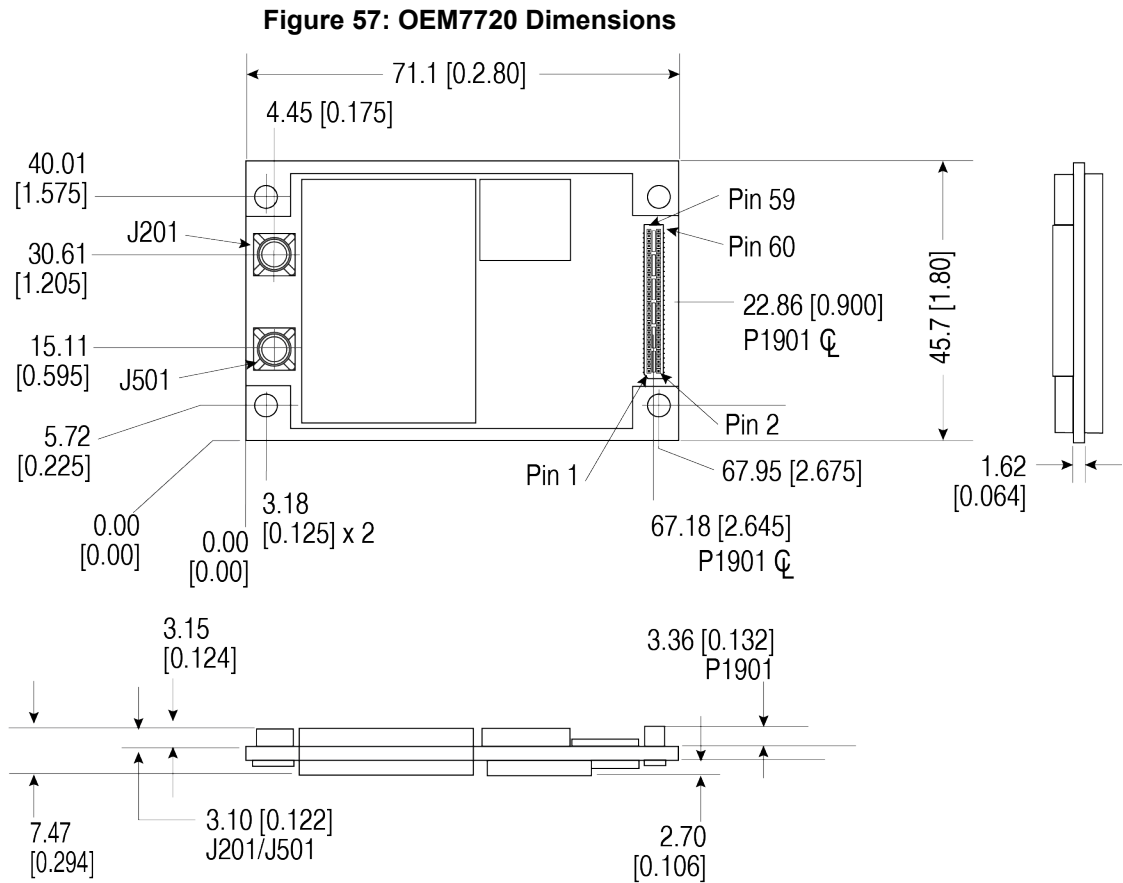

Notes: OEM7720

Dimensions are in millimetres [inches].

Connectors:

(a) J201/J501 Huber + Shuhner 82_MMBX-S50-0-1/111 NE or 82_MMBX-0-1/111 NH or 82_MMBX-S50-0-1/111 NM

(b) P1901 Samtec ASP-189258-01

Figure 58: OEM7720 Keep-outs

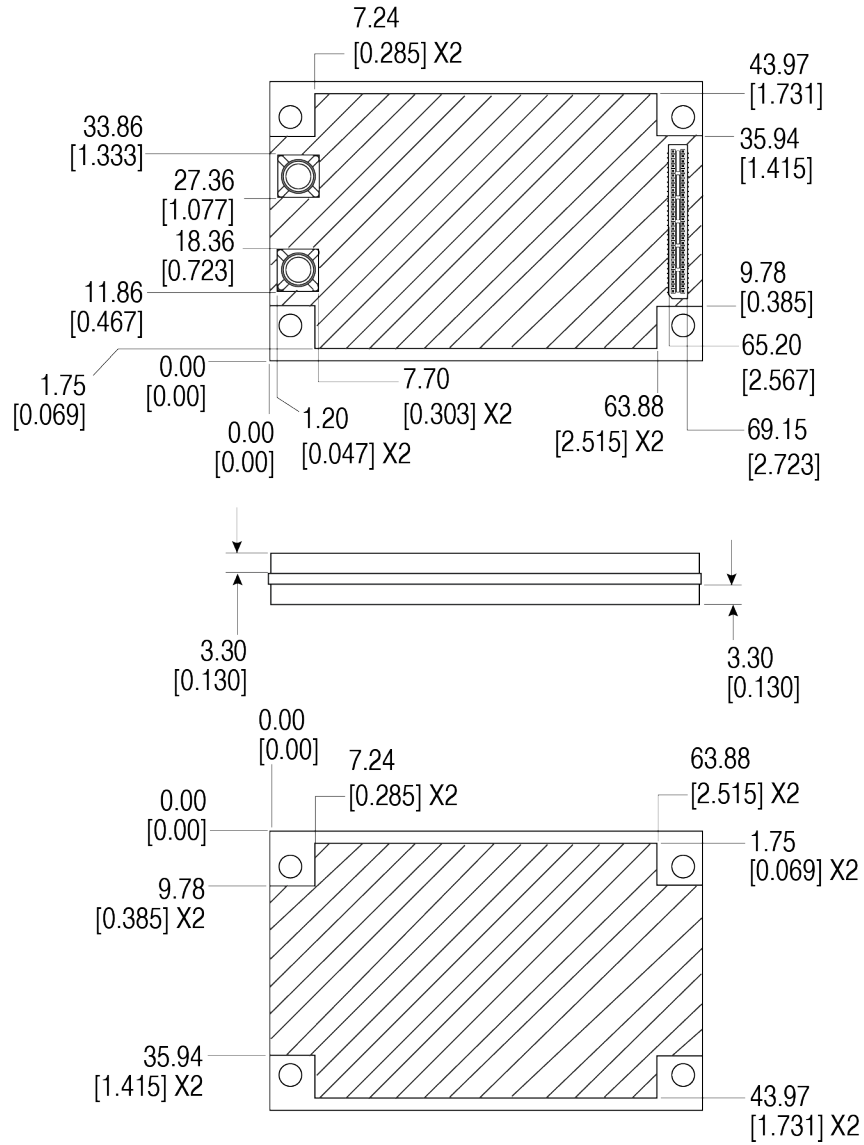

Dimensions are in millimetres [inches].

Figure 59: OEM7720 Mounting Surfaces

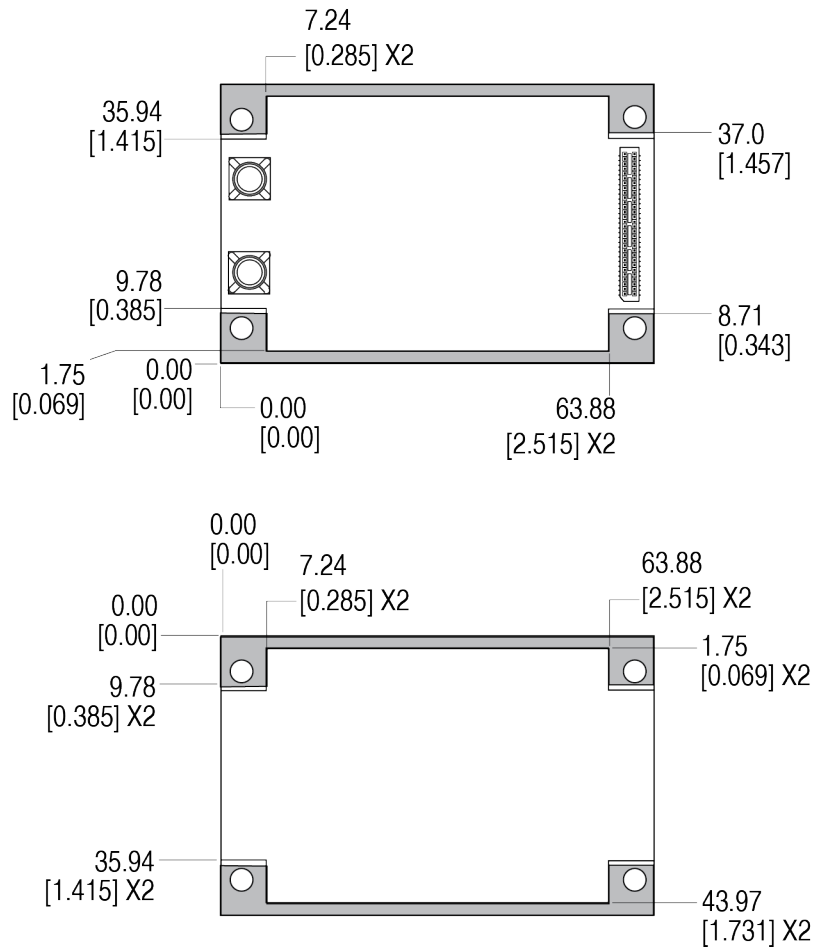

Dimensions are in millimetres [inches].

The mounting surfaces are shown in gray.

These mounting surfaces are designed to work with mounting rails. For information about mounting the OEM7720, refer to *Mounting the Printed Circuit Board* on page 31.



Assembly tolerances must be considered when using mounting rail features.



For information about the recommended mating connector, refer to *Table 2: OEM7 Communication and I/O Connectors* on page 40.

E.3 OEM7720 Electrical and Environmental Specifications

Table 48: OEM7720 Environmental Specifications

Operating Temperature	-40°C to +85°C ¹
Storage Temperature	-55°C to +95°C
Humidity	95% non-condensing
Random Vibration	MIL-STD-810G (CH1), Method 514.7, Category 24 (20 g RMS) ²
Sinusoidal Vibration	IEC 60068-2-6
Bump	ISO 9022-31-06 (25 g)
Shock	
Operating	MIL-STD-810G (CH1), Method 516.7 (40 g)
Non-operating	MIL-STD-810G (CH1), Method 516.7 (75 g)
Acceleration	MIL-STD-810G (CH1), Method 513.7 (16 g)

Table 49: OEM7720 Power Requirements

Voltage	+3.0 to +5.0 VDC
Allowable Input Voltage Ripple	100 mV p-p maximum
Power Consumption	<p>1.8 W typical, GPS L1, GLONASS L1 2.3 W typical, GPS L1/L2, GLONASS L1/L2 2.7 W typical, all constellations, all frequencies, plus L-Band</p> <div style="border: 1px solid black; padding: 5px; margin-top: 10px;">  <p>These are typical values using serial ports without interference mitigation. These values can change with the number of satellites in view, firmware version, data logging rates and features in use. Use them as a guide for what you might expect but not as absolute values</p> </div>
Inrush Current	2.0 A for less than 1.8 ms (typical)

Table 50: OEM7720 RF Input/LNA Power Output

Antenna Connector	MMBX female, 50 Ω nominal impedance
-------------------	-------------------------------------

¹May require an optional heat spreader in high current configurations. See *OEM7720 Accessory Heat Spreader* on page 38 for details.

²Requires mechanical mounting rails to meet 20 g; meets 7.7 g without rails.

Cascaded antenna LNA gain (before receiver)	Firmware 7.04 and later	HDR disabled	+15 dB to +55 dB, 26 dB typical
		HDR enabled	+20 dB to +55 dB, 30 dB typical
	Firmware before 7.04	HDR disabled	+15 dB to +40 dB, 26 dB typical
		HDR enabled	+20 dB to +40 dB, 30 dB typical
RF Input Frequencies	GPS L1:	1575.42 MHz	
	GPS L2:	1227.60 MHz	
	GPS L5:	1176.45 MHz	
	GLONASS L1:	1593-1610 MHz	
	GLONASS L2:	1237-1254 MHz	
	GLONASS L3:	1202.025 MHz	
	Galileo E1:	1575.42 MHz	
Galileo E5a:	1176.45 MHz		
Galileo E5b:	1207.14 MHz		
Galileo E5:	1191.795 MHz		
BeiDou B1l:	1561.098 MHz		
	BeiDou B1C	1575.42 MHz	
	BeiDou B2l:	1207.14 MHz	
	BeiDou B2a:	1176.45 MHz	
	BeiDou B2b:	1207.14 MHz	
L-Band:	1525 to 1560 MHz		
LNA Power	<p>+5.0 VDC \pm5%, 0 mA to 200 mA (supplied by card through center conductor of RF connector).</p> <p>LNA Power is generated from the voltage supply input for the OEM7720.</p>		

E.4 OEM7720 Data Communication Specifications

Table 51: Data Communications Interface

COM1	
Electrical format	LVC MOS
Data rates ¹	2400, 4800, 9600 (default), 19200, 38400, 57600, 115200, 230400 or 460800 bit/s.
Signals supported	COM1_Tx, COM1_Rx, COM1_RTS, COM1_CTS
Electrostatic discharge protection	No
COM2	
Electrical format	LVC MOS
Data rates ¹	2400, 4800, 9600 (default), 19200, 38400, 57600, 115200, 230400 or 460800 bit/s.
Signals supported	COM2_Tx, COM2_Rx, COM2_RTS, COM2_CTS
Electrostatic discharge protection	No
COM3	
Electrical format	LVC MOS
Data rates ¹	2400, 4800, 9600 (default), 19200, 38400, 57600, 115200, 230400 or 460800 bit/s.
Signals supported	COM3_Tx, COM3_Rx
Electrostatic discharge protection	No
COM4	
Electrical format	LVC MOS
Data rates ¹	2400, 4800, 9600 (default), 19200, 38400, 57600, 115200, 230400 or 460800 bit/s.
Signals supported	COM4_Tx, COM4_Rx
Electrostatic discharge protection	No

¹Data rates higher than 115200 bit/s are not supported by standard PC hardware. Special PC hardware may be required for higher rates, including 230400 bit/s and 460800 bit/s.

COM5	
Electrical format	LVC MOS ¹
Data rates ¹	2400, 4800, 9600 (default), 19200, 38400, 57600, 115200, 230400 or 460800 bit/s.
Signals supported	COM5_Tx, COM5_Rx
Electrostatic discharge protection	No
CAN Bus	
Electrical Format	LVC MOS
Data rates	1 Mbps maximum. CAN Bus throughput is determined by slowest device on the bus
Signals supported	CAN0 and CAN1
USB	
Electrical format	Conforms to USB 2.0
Data rates	Hi-speed (480 Mb/s)
Signals supported	USB0 D+, USB0 D- USB1 D+, USB1 D-
ETHERNET	
Physical layer	10BASE-T/100BASE-TX

¹Upon power-up, COM5 is enabled by default. COM5 is multiplexed with COM2 hardware flow control.

E.5 OEM7720 Strobe Specifications

Table 52: OEM7720 Strobes Description

Strobes	Input/Output	Factory Default	Comment
ERROR	Output	Active high	Normally low. A high output on this pin indicates that the receiver is in an error state. For information about the cause of the error, log the RXSTATUS log.
EVENT_IN1 EVENT_IN2 EVENT_IN3 EVENT_IN4	Input Leading edge triggered	Active low	Input marks for which a pulse greater than 150 ns triggers certain logs to be generated. (Refer to the MARKxPOS and MARKxTIME logs and ONMARK trigger.) Polarity is configurable using the EVENTINCONTROL command.
EVENT_OUT1 EVENT_OUT2 EVENT_OUT3 EVENT_OUT4	Output	Active low	Programmable variable frequency outputs ranging from 0 Hz to 50 MHz (refer to the EVENTOUTCONTROL command).
ME_RDY	Output	Active high	Indicates to the host system that the receiver is ready to receive commands. This signal is not asserted while booting or during a reset. <div style="border: 1px solid black; padding: 5px; margin-top: 10px;"> <p> If an error is detected during receiver operation (for example, an over temperature condition), the ERROR signal is asserted and the ME_RDY signal will normally remain asserted: commands can still be sent to the receiver under these conditions. At the time ERROR is asserted, POS_VALID signal is changed to not asserted. In the rare case of a fatal, unrecoverable error that leads to a reboot of the receiver, ME_RDY, ERROR and POS_VALID are all not asserted while the receiver restarts.</p> </div>
POS_Valid (Position Valid)	Output	Active high	Indicates a valid GNSS position solution is available.

Strobes	Input/Output	Factory Default	Comment
nRESET_IN	Input	Active low	<p>Reset signal input from external system; active low.</p> <p>This pin must be held low for >20 μs while stable power is already applied, to reset the OEM7720 card.</p> <p>It is recommended to hold the nRESET_IN pin low for a >150 ms when initially applying power to the card, giving the power supply time to stabilize before the card starts to boot.</p>
PPS	Output	Active low	<p>A time synchronization output. This is a pulse where the leading edge is synchronized to receiver calculated GNSS Time. The polarity, period and pulse width can be configured using the PPSCONTROL command</p>

Table 53: OEM7720 Strobe Electrical Specifications

Strobe	Sym	Min (V)	Max (V)	Current (mA)
ERROR	V _{OL}		0.2	8
	V _{OH}	3.1		
EVENT_IN1 (Mark) EVENT_IN2 (Mark2) EVENT_IN3 (Mark3) EVENT_IN4 (Mark4)	V _{IL}		0.8	-
	V _{IH}	1.7		
EVENT_OUT1 EVENT_OUT2 EVENT_OUT3 EVENT_OUT4	V _{OL}		0.2	8
	V _{OH}	3.1		
ME_RDY	V _{OL}		0.2	4
	V _{OH}	3.1		
POS_VALID	V _{OL}		0.55	8
	V _{OH}	2.3		
nRESET_IN	V _{IL}		0.8	-
	V _{IH}	2.55		
PPS	V _{OL}		0.55	24
	V _{OH}	2.3		

E.6 OEM7720 Interface Connector

E.6.1 P1901 Main Connector 60-Pin Socket

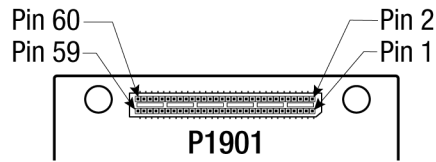

For information about the recommended mating connector, refer to *Table 2: OEM7 Communication and I/O Connectors* on page 40.

Pin	Signal Name	Signal Type	Signal Direction	V _{IL} Max (V)	V _{IH} Min (V)	V _{OL} Max (V)	V _{OH} Min (V)	Drive (mA)	Description
1	3V3	Power	Input	-	-	-	-	-	3.2 to 5.0 V ±5% supply input
2	3V3	Power	Input	-	-	-	-	-	3.2 to 5.0 V ±5% supply input
3	COM2_TXD	3.3V CMOS	Output	-	-	0.2	3.1	4	COM2 Transmit Data (UART)
4	COM1_TXD	3.3V CMOS	Output	-	-	0.55	2.3	24	COM1 Transmit Data (UART)
5	COM5_TXD/ COM2_RTS	3.3V CMOS	Output	-	-	0.2	3.1	4	This pin is internally multiplexed. COM5_TXD is the default. COM5_TXD: COM5 Transmit Data (UART). COM2_RTS: COM2 Request to Send Optional hardware flow control signal for the COM2 serial port.
6	COM1_RTS	3.3V CMOS	Output	-	-	0.2	3.1	4	COM1 Request to Send Optional hardware flow control signal for the COM1 serial port.
7	GND	Ground	-	-	-	-	-	-	Ground reference
8	GND	Ground	-	-	-	-	-	-	Ground reference

Pin	Signal Name	Signal Type	Signal Direction	V _{IL} Max (V)	V _{IH} Min (V)	V _{OL} Max (V)	V _{OH} Min (V)	Drive (mA)	Description
9	COM2_RXD	3.3V CMOS	Input	0.8	1.7	-	-	-	COM2 Receive Data (UART)
10	COM1_RXD	3.3V CMOS	Input	0.8	1.7	-	-	-	COM1 Receive Data (UART)
11	COM5_RXD/ COM2_CTS	3.3V CMOS	Input	0.8	1.7	-	-	-	This pin is internally multiplexed. COM5_RXD is the default. COM5_RXD: COM5 Receive Data (UART). COM2_CTS: COM2 Clear to Send Optional hardware flow control signal for the COM2 serial port.
12	COM1_CTS	3.3V CMOS	Input	0.8	1.7	-	-	-	COM1 Clear To Send Optional hardware flow control signals for the COM1 serial port.
13	COM4_RXD	3.3V CMOS	Input	0.8	1.7	-	-	-	COM4 Receive Data (UART)
14	COM3_RXD	3.3V CMOS	Input	0.8	1.7	-	-	-	COM3 Receive Data (UART)
15	STATUS_GREEN	3.3V CMOS	Output	-	-	0.2	3.1	4	Used to indicate the state of the receiver or provide error codes. These outputs provide the same information as the Status Indicator LED (see <i>Status LED</i> on page 88). STATUS_GREEN high and STATUS_RED low represents a Green LED.
16	STATUS_RED	3.3V CMOS	Output	-	-	0.2	3.1	4	STATUS_GREEN high and STATUS_RED high represents a Yellow LED. STATUS_GREEN low and STATUS_RED high represents a Red LED.

Pin	Signal Name	Signal Type	Signal Direction	V _{IL} Max (V)	V _{IH} Min (V)	V _{OL} Max (V)	V _{OH} Min (V)	Drive (mA)	Description
17	EVENT_OUT1	3.3V CMOS	Output	-	-	0.2	3.1	8	EVENT1 (Mark1) Output Rising edge triggered. Outputs a user-specified timing signal. Can be synchronized with PPS. Supports Variable Frequency Output function.
18	ME_RDY	3.3V CMOS	Output	-	-	0.2	3.1	4	Receiver Ready (Active High) Indicates to the host system that the receiver is ready to receive commands. This signal is not asserted while booting or during a reset. Internal 2.2 kΩ pull down.
19	COM4_TXD	3.3V CMOS	Output	-	-	0.2	3.1	4	COM4 Transmit Data (UART)
20	COM3_TXD	3.3V CMOS	Output	-	-	0.2	3.1	4	COM3 Transmit Data (UART)
21	ERROR	3.3V CMOS	Output	-	-	0.2	3.1	4	Error Indicator (Active High) Normally low. A high output on this pin indicates that the receiver is in an error state. Internal 2.2 kΩ pull down.
22	POS_VALID	3.3V CMOS	Output	-	-	0.2	3.1	4	Position Valid Output (Active High) A high output on this pin indicates that the receiver has computed a valid GNSS position. Internal 10 kΩ pull down.

Pin	Signal Name	Signal Type	Signal Direction	V _{IL} Max (V)	V _{IH} Min (V)	V _{OL} Max (V)	V _{OH} Min (V)	Drive (mA)	Description
23	EVENT_OUT3	3.3V CMOS	Output	-	-	0.2	3.1	8	EVENT3 (Mark3) Output Rising edge triggered. Outputs a user-specified timing signal. Can be synchronized with PPS. Supports Variable Frequency Output function.
24	PPS	3.3V CMOS	Output	-	-	0.55	2.3	24	Pulse Per Second output This signal defaults to one pulse per second but may be altered across a wide range of frequencies using software commands. Edges can be synchronized to GNSS time reference.
25	EVENT_OUT4	3.3V CMOS	Output	-	-	0.2	3.1	8	EVENT4 (Mark4) Output Rising edge triggered. Outputs a user-specified timing signal. Can be synchronized with PPS. Supports Variable Frequency Output function.
26	EVENT_OUT2	3.3V CMOS	Output	-	-	0.2	3.1	8	EVENT2 (Mark2) Output Rising edge triggered. Outputs a user-specified timing signal. Can be synchronized with PPS. Supports Variable Frequency Output function.
27	GND	Ground	-	-	-	-	-	-	Ground reference
28	GND	Ground	-	-	-	-	-	-	Ground reference

Pin	Signal Name	Signal Type	Signal Direction	V _{IL} Max (V)	V _{IH} Min (V)	V _{OL} Max (V)	V _{OH} Min (V)	Drive (mA)	Description
29	EVENT_IN2	3.3V CMOS	Input	0.8	1.7	-	-	-	EVENT2 (Mark2) input Rising or falling edge triggered. This input is used to provide a position or time data log based on an external trigger. Internal 10 kΩ pull up.
30	EVENT_IN1	3.3V CMOS	Input	0.8	1.7	-	-	-	EVENT1 (Mark1) input Rising or falling edge triggered. This input is used to provide a position or time data log based on an external trigger. Internal 10 kΩ pull up.
31	EVENT_IN4	3.3V CMOS	Input	0.8	1.7	-	-	-	EVENT4 (Mark4) input Rising or falling edge triggered. This input is used to provide a position or time data log based on an external trigger. Internal 10 kΩ pull up.
32	EVENT_IN3	3.3V CMOS	Input	0.8	1.7	-	-	-	EVENT3 (Mark3) input Rising or falling edge triggered. This input is used to provide a position or time data log based on an external trigger. Internal 10 kΩ pull up.
33	GND	Ground	-	-	-	-	-	-	Ground reference
34	GND	Ground	-	-	-	-	-	-	Ground reference
35	CAN1_RXD	3.3V CMOS	Input	0.8	1.7	-	-	-	CAN1 Receive Data This is a CMOS-level signal, requiring an external CAN transceiver.

Pin	Signal Name	Signal Type	Signal Direction	V _{IL} Max (V)	V _{IH} Min (V)	V _{OL} Max (V)	V _{OH} Min (V)	Drive (mA)	Description
36	CAN0_TXD	3.3V CMOS	Output	-	-	0.2	3.1	4	CAN0 Transmit Data This is a CMOS-level signal, requiring an external CAN transceiver.
37	CAN1_TXD	3.3V CMOS	Output	-	-	0.2	3.1	4	CAN1 Transmit Data This is a CMOS-level signal, requiring an external CAN transceiver.
38	CAN0_RXD	3.3V CMOS	Input	0.8	1.7	-	-	-	CAN0 Receive Data This is a CMOS-level signal, requiring an external CAN transceiver.
39	I2C_SDA	3.3V CMOS Open drain	I/O	0.7	2.0	0.4	2.9	-	I2C data line Open drain signal with internal 2.2 kΩ pull up to 3.3 V
40	I2C_SCL	3.3V CMOS Open drain	Output	-	-	0.4	3.1	-	I2C clock line Open drain signal with internal 2.2 kΩ pull up to 3.3 V
41	SPI_MOSI	3.3V CMOS	Output	-	-	0.2	3.1	4	Serial Peripheral Interface Master Output/Slave Input
42	SPI_nCS	3.3V CMOS	Output	-	-	0.2	3.1	4	Serial Peripheral Interface Chip Select (Active Low)
43	SPI_MISO	3.3V CMOS	Input	0.8	1.7	-	-	-	Serial Peripheral Interface Master Input/Slave Output
44	SPI_SCLK	3.3V CMOS	Output	-	-	0.2	3.1	4	Serial Peripheral Interface Serial Clock
45	GND	Ground	-	-	-	-	-	-	Ground reference
46	GND	Ground	-	-	-	-	-	-	Ground reference

Pin	Signal Name	Signal Type	Signal Direction	V _{IL} Max (V)	V _{IH} Min (V)	V _{OL} Max (V)	V _{OH} Min (V)	Drive (mA)	Description
47	USB1_D-	Analog	I/O	-	-	-	-	-	USB1 signal. This is one half of the USB1 differential pair. USB1_D+ and USB1_D- must be length-matched and routed as a 90 Ω differential pair.
48	USB0_D+	Analog	I/O	-	-	-	-	-	USB0 signal. This is one half of the USB0 differential pair. USB0_D+ and USB0_D- must be length-matched and routed as a 90 Ω differential pair.
49	USB1_D+	Analog	I/O	-	-	-	-	-	USB1 signal. This is one half of the USB1 differential pair. USB1_D+ and USB1_D- must be length-matched and routed as a 90 Ω differential pair.
50	USB0_D-	Analog	I/O	-	-	-	-	-	USB0 signal. This is one half of the USB0 differential pair. USB0_D+ and USB0_D- must be length-matched and routed as a 90 Ω differential pair.
51	UID	3.3V CMOS	Input	-	-	-	-	-	USB Port Mode Select. Leave this pin floating to put USB0 into Device mode and USB1 into Host mode. Tie this pin to GND to put USB0 into Host mode and USB1 into Device mode. Internal 10 kΩ pull up

Pin	Signal Name	Signal Type	Signal Direction	V _{IL} Max (V)	V _{IH} Min (V)	V _{OL} Max (V)	V _{OH} Min (V)	Drive (mA)	Description
52	USB0_VBUS	Power	I/O	3.3	5.25	-	-	-	<p>When the USB port mode is set to Host, this pin is an output.</p> <p>When the USB port mode is set to Device, this pin is an input.</p> <p>Host or Device mode is set using the USB_Port_Mode_Select pin (Pin 51).</p> <p>When an input, requires a voltage between 3.3 V and 5.25 V.</p> <p>When an output, provides 5 V for hosted devices</p> <p>USB0_VBUS is capable of providing up to 200 mA to a hosted USB device. Devices that require more than 200 mA must be powered separately.</p>
53	nRESET_IN	3.3V CMOS	Input	0.8	2.55	-	-	-	<p>Reset Input (Active Low)</p> <p>Resets the OEM7720 receiver card. This pin must be held low for >20 μs while stable power is already applied, to reset the OEM7720 card.</p> <p>It is recommended to hold the nRESET_IN pin low for a >150 ms when initially applying power to the card, giving the power supply time to stabilize before the card starts to boot.</p> <p>Internal 10 kΩ pullup.</p>
54	GND	Ground	-	-	-	-	-	-	Ground reference

Pin	Signal Name	Signal Type	Signal Direction	V _{IL} Max (V)	V _{IH} Min (V)	V _{OL} Max (V)	V _{OH} Min (V)	Drive (mA)	Description
55	ETH_LINK_ACT	3.3V CMOS	Output	-	-	0.2	3.1	8	<p>Ethernet Link and Activity LED indicator.</p> <p>Polarity of the indicator signal is low. When there is an active link, the pin is low. When there is activity on the link, the pin outputs a blink signal.</p> <div style="border: 1px solid black; padding: 5px; width: fit-content;">  Do not use ETH_BIAS to supply the LED. </div>
56	ETH_BIAS	Power	Output	-	-	-	-	-	DC Bias source for the Ethernet magnetics. Do not use ETH_BIAS to supply any other circuitry.
57	ETH_RX+	Analog	Input	-	-	-	-	-	Ethernet Receive One half of the Ethernet receive differential pair. ETH_RX+ and ETH_RX- must be routed as a 100 Ω differential pair.
58	ETH_TX+	Analog	Output	-	-	-	-	-	Ethernet Transmit One half of the Ethernet transmit differential pair. ETH_TX+ and ETH_TX- must be routed as a 100 Ω differential pair.
59	ETH_RX-	Analog	Input	-	-	-	-	-	Ethernet Receive One half of the Ethernet receive differential pair. ETH_RX+ and ETH_RX- must be routed as a 100 Ω differential pair.

Pin	Signal Name	Signal Type	Signal Direction	V _{IL} Max (V)	V _{IH} Min (V)	V _{OL} Max (V)	V _{OH} Min (V)	Drive (mA)	Description
60	ETH_TX-	Analog	Output	-	-	-	-	-	Ethernet Transmit One half of the Ethernet transmit differential pair. ETH_TX+ and ETH_TX- must be routed as a 100 Ω differential pair.

APPENDIX F Receiver Card Interface Examples

The OEM7 receiver cards provide a number of 3.3V CMOS-level I/O pins for status indication and timing:

- **COMx**: CMOS-level UART ports
- **Ethernet**: 10/100 Ethernet port
- **CAN1** and **CAN2**: CMOS-level CAN ports (external CAN transceivers required)
- **PPS**: Output pulse providing time reference signal (software configurable output rate, defaults to 1 Pulse Per Second)
- **EVENTx_OUT**: Variable Frequency output (a software-configurable clock output similar to PPS, off by default). (The EVENT1_OUT signal may also be referred to as an VARF.)
- **PV**: Position Valid (This signal drives high when the receiver has calculated a valid position)
- **EVENTx_IN**: Event inputs (with configurable polarity)
- **USERIO**: A user defined general purpose input or output (OEM729 only)

These I/O require additional ESD protection if they are to be routed to enclosure connectors. A protection circuit similar to the following examples must be used on any OEM7 CMOS-level signals that will be routed to an enclosure connector. The ferrite bead and small-value capacitor provide some immunity to electrostatic discharge events, but also serve to reduce radiated and conducted emissions from the enclosure.

F.1 EVENT_IN, EVENT_OUT and PPS Signal Protection

The following schematic shows appropriate signal conditioning for EVENT_IN (MKI), EVENT_OUT (VARF) and PPS (TIMEMARK) signals.

Figure 60: Protection and Buffering for EVENT_IN, PPS and EVENT_OUT signals

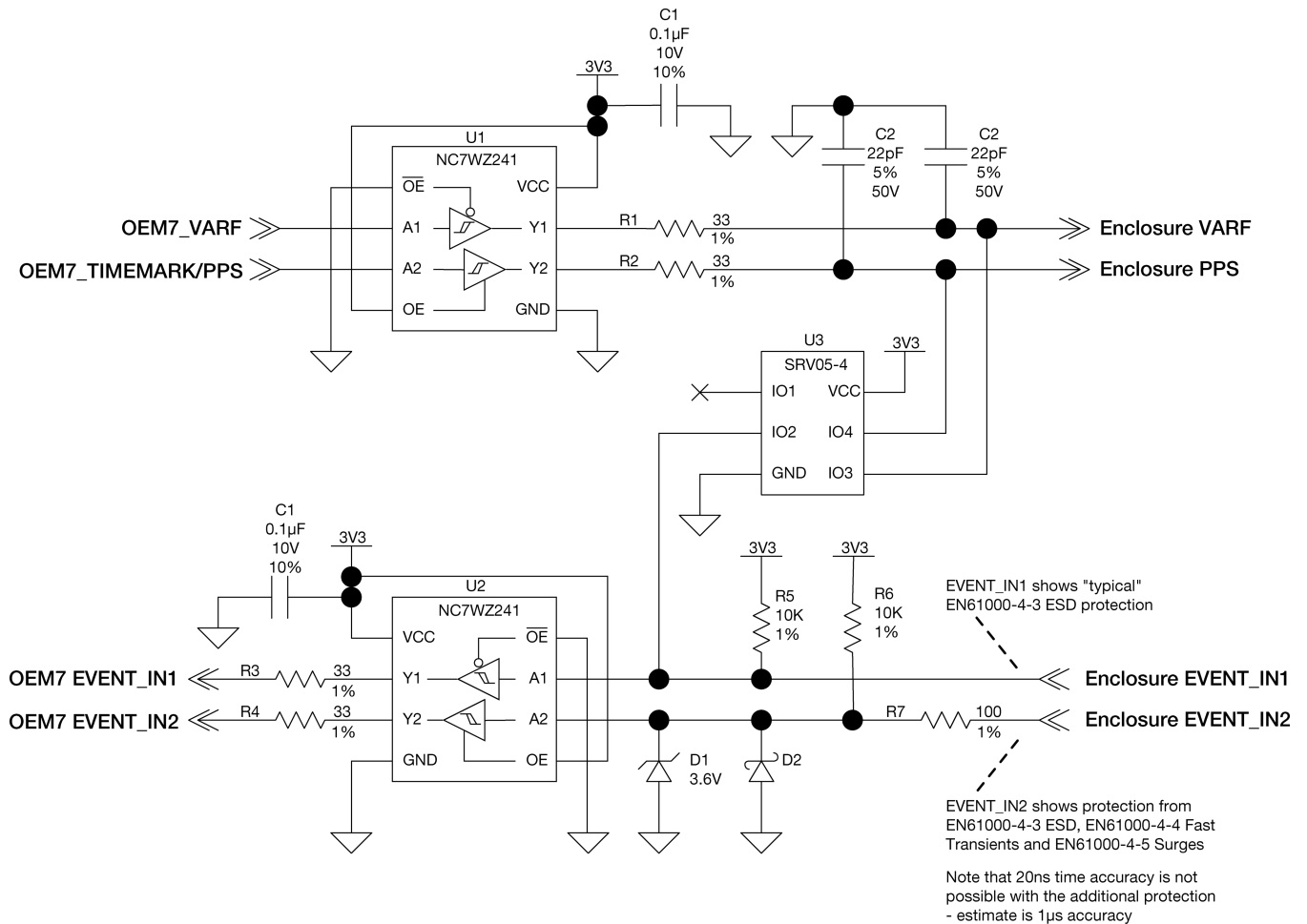

The buffers (U1, U2) are chosen to provide additional drive strength for long cables. The series terminations (R1, R2, R3, R4) are present to allow for signal integrity adjustments (to reduce overshoot/undershoot, etc.). The passive component values may require tuning, depending on the application.

The TVS (U3) provides protection from ESD/EFT events and some induced power line surges. There are two implementations shown for the EVENT_IN signals. EVENT_IN1 is shown with basic ESD/EFT protection, while EVENT_IN2 is shown with additional surge protection for harsh environments (see D1, R7, D2, D3 and R9). If the additional surge protection is to be used on a design, the buffer must be included as well. This design has been used to protect EVENT_IN signals from EN61000-4-5 induced surges up to 2kV on several NovAtel enclosure products. If nanosecond-level timing is critical to the application, this protection circuit may be unsuitable, as it causes a timing shift of a few microseconds to the EVENT signal (heavily dependent on temperature).

The 10 kΩ pullups (R5, R6) are required if the buffers are used on the EVENT_IN lines. If the buffers are not used, the OEM7 cards have built-in 10 kΩ pullup resistors – external pull resistors are not required.

Table 54: EVENT_IN, EVENT_OUT and PPS Pin Designation

	OEM719	OEM729	OEM7600	OEM7700	OEM7720
Connector	P1701	P1802	P1701	P2001	P1901
EVENT_IN1	9 ¹	8	30	30	30
EVENT_IN2	7 ²	7 ³	29	29	29
EVENT_IN3	–	–	32	32	32
EVENT_IN4	–	–	31	31	31
PPS	19	4	24	24	24
EVENT_OUT1/VARF	6 ⁴	3	17	17	17
EVENT_OUT2	–	–	26	26	26
EVENT_OUT3	–	–	23	23	23
EVENT_OUT4	–	–	25	25	25

Table 55: Bill of Materials (critical components)

Designator	Manufacturer	Manufacturer Part Number
D1	On Semiconductor	MMSZ5227BT1G
D2	Comchip Technology	CDBU00340
U1, U2	Fairchild Semiconductor	NC7WZ241L8X
U3	Semtech	SRV05-4A.TCT

¹This pin is multiplexed with the COM3 transmit signal and is not available if COM3 is enabled.

²This pin is multiplexed with the CAN1 transmit signal and is not available if CAN1 is enabled.

³This pin is multiplexed with the COM3 receive signal and is not available when COM3 is enabled. See *P1802 Main Connector 24-Pin Header* on page 167 for more information.

⁴This pin is multiplexed with the CAN1 receive signal and is not available if CAN1 is enabled.

F.2 Position Valid (PV) LED Driver

The PV signal may be used to indicate that the receiver card has computed a valid position. Many NovAtel enclosure products use it to drive a green LED on the enclosure. It may also be used to monitor the status of the receiver with an external microcontroller.

If the LED requires less than 6 mA to drive, and can be operated from a 3.3 V supply, the PV pin may be used to drive the LED directly (with an appropriate current-limiting resistor). If the LED must be driven from a different supply voltage or requires more than 6 mA, a buffer must be used.

A simple buffer – suitable for driving a high-brightness LED from a 5 V supply – is shown below. The value for R2 was selected to limit the LED current to 10 mA (assuming $V_{CE(Q1,sat)}=0.25\text{ V}$, $V_{FWD(D1)}=3.4\text{ V}$). This circuit will not compensate for the forward voltage change over temperature (and the resulting brightness changes).

Figure 61: OEM7 Buffer for Driving High-Brightness LEDs from PV

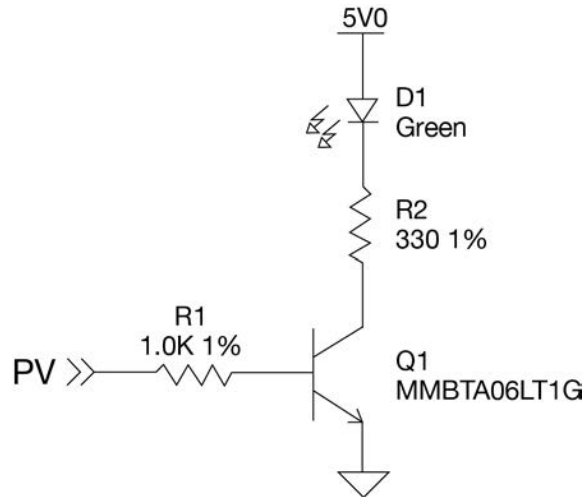

Table 56: PV Pin Designation

	OEM719	OEM729	OEM7600	OEM7700	OEM7720
Connector	P1701	P1802	P1701	P2001	P1901
PV	17	10	22	22	22

Table 57: PV LED Driver Bill of Materials (critical components)

Designator	Manufacturer	Manufacturer Part Number
Q1	ON Semiconductor	MMBTA06LT3G
	Fairchild Semiconductor	MMBTA06LT1G
	Diodes Inc	MMBTA06-7-F
D1	OSRAM	LT L29S-N1R2-25-Z

F.3 Communication Ports

The COM ports on OEM7 receivers (except COM1 on the OEM729) are CMOS-level I/O pins only. These ports require the addition of an RS-232 or RS-422 transceiver to provide appropriate signal levels. Most RS-232 or RS-422 transceivers will provide some ESD protection (for harsh environments, additional protection may be required).



COM1 on the OEM729 uses RS-232 protocol by default. This port can be changed to RS-422 protocol using the **SERIALPROTOCOL** command.

A combination of a series ferrite bead and small-value shunt capacitor is recommended on any RS-232/RS-422 lines that leave the enclosure (similar to the arrangement used on the I/O ports and CAN interfaces). Many of the available transceivers provide protection for ESD events to $\pm 15\text{kV}$ – if additional protection is required, an external TVS with a working voltage of $\pm 15\text{V}$ to $\pm 25\text{V}$ will be required.

F.4 CAN Controller Ports

OEM7 receivers provide 3.3 V CMOS-level CAN controller ports. An external CAN transceiver is required. The following figure shows a typical CAN transceiver implementation.

The combination of ferrite beads and small-value capacitors are not necessarily required but may provide improved EMI performance. A low-capacitance TVS device is shown on the schematic to provide ESD protection.

Figure 62: OEM7 CAN Transceiver Example

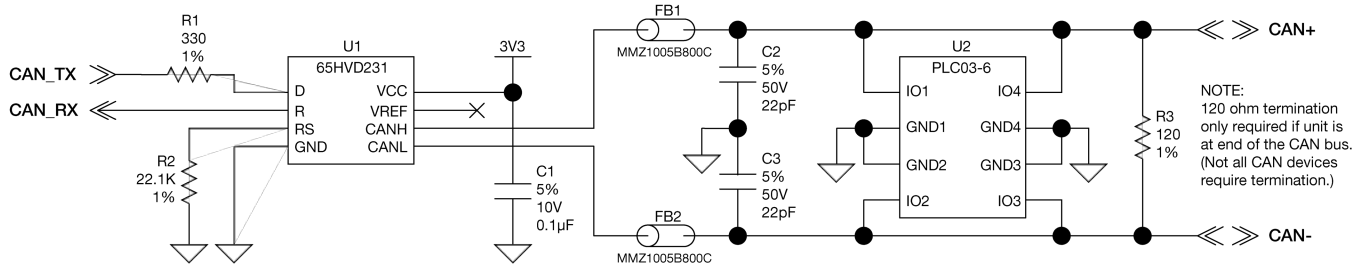

Table 58: CAN Transceiver Pin Designation

	OEM719	OEM729	OEM7600	OEM7700	OEM7720
Connector	P1701 ¹	P1803	P1701	P2001	P1901
CAN1TX	7	10	36	36	36
CAN1RX	6	11	38	38	38
CAN2TX	20	12	37	37	37
CAN2RX	8	13	35	35	35

The 120Ω termination resistor should only be used when the CAN device is used at one end of the CAN bus. Multiple terminations along the length of the CAN bus will degrade performance for all CAN devices on that bus.

The slew rate adjustment resistor (R2) value shown sets the slew rate for applications for SAE J1939 agricultural applications. Other applications may require a different slew rate. Refer to the transceiver data sheet for more information.

Table 59: CAN Transceiver Example Bill of Materials (critical components)

Designator	Manufacturer	Manufacturer Part Number
FB1, FB2	TDK	MMZ1005B800C
U1	Texas Instruments	SN65HVD231QD
U2	Bourns	CDNBS08-PLC03-6

¹Pins 6 and 7 are multiplexed with other signals and may not be available when certain features are enabled. See *OEM719 Interface Connector* on page 150 for more information.

F.5 USB Interface



This section describes the interface requirements for an OEM7 receiver card USB port. For general information about the OEM7 receiver card USB ports, see *USB Ports* on page 51.

OEM7 receivers include an USB 2.0 device interface set to either Full-Speed (12 Mb/s) or High-Speed (480 Mb/s) transfer rate. On the OEM719 and OEM729 receivers, the transfer rate for the USB Device port is Full-Speed (12 Mb/s). The USB device interface on the OEM7600, OEM7700 and OEM7720 receivers use the High-Speed (480 Mb/s) transfer rate. The device interface will not auto-negotiate the speed with the Host computer.

It is imperative for signal integrity and EMI reasons that the differential data traces be routed as a 90Ω differential pair. Use of a small-value common-mode choke (as shown in *Figure 63: OEM7 USB Device Interface Example* below) may improve the radiated emissions performance (but should not be necessary).

Any stubs on the traces must be kept as short as possible and it is strongly recommended not to change reference planes. Match the USB differential pair (D+ and D- trace lengths) to within 3 mm or less.

The common-mode choke and ESD protection should be placed as close as possible to the USB connector (J1).

Figure 63: OEM7 USB Device Interface Example

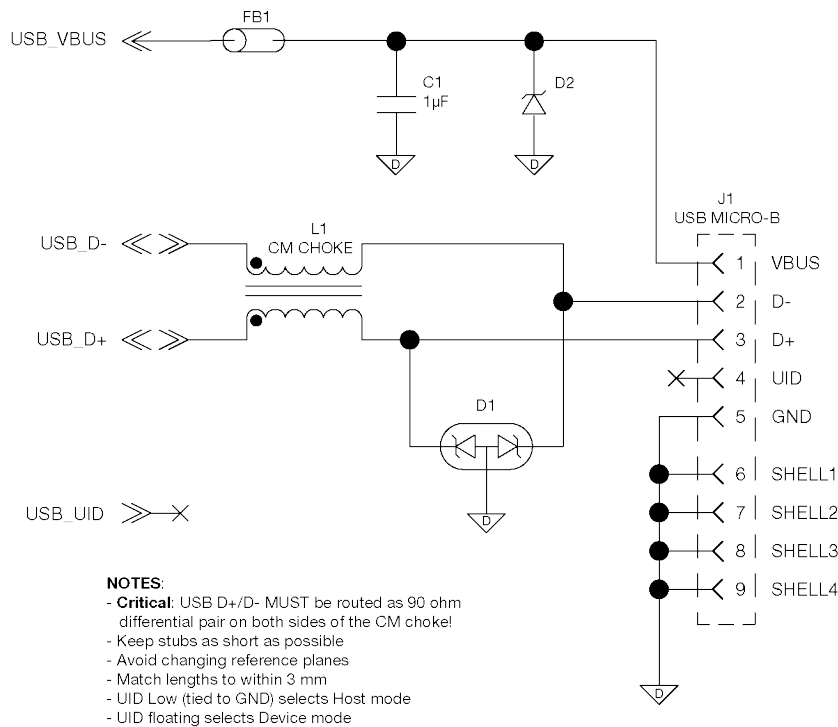

Table 60: USB Device Interface Pin Designation

	OEM719	OEM729	OEM7600	OEM7700	OEM7720
Connector	P1701	P1802	P1803	P2001	P1901

	OEM719	OEM729	OEM7600	OEM7700	OEM7720
USB0_D-	3	21	-	50	50
USB0_D+	4 ¹	22	-	48	48
USB1_D-	-	-	-	47	47
USB1_D+	-	-	-	49	49
USB_VBUS	-	-	15	52	52
UID	-	-	14	51	51

Table 61: USB Device Interface Example Bill of Materials

Designator	Manufacturer	Manufacturer Part Number
D1	On Semiconductor	ESD7L5.0DT5G
D2	On Semiconductor	ESD5Z6.0T1G
FB1	TDK	MMZ1005B800C
L1	Würth Electronics	744230900
J1	FCI	10104110-0001LF

Figure 64: OEM7 USB Host Device Interface Example

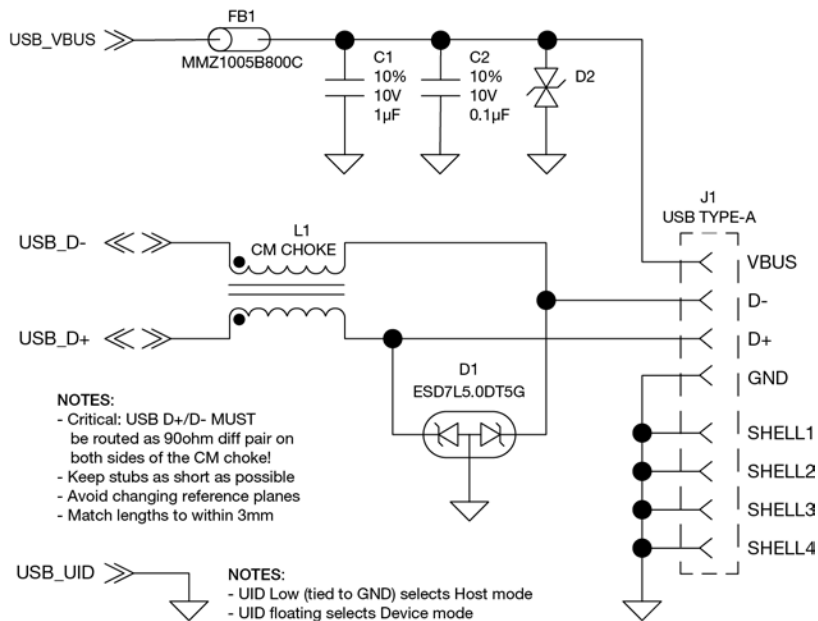

¹This pin is multiplexed with the COM3 receive signal and is not available when COM3 is enabled.

Table 62: USB Host Interface Pin Designation

	OEM719	OEM729	OEM7600	OEM7700	OEM7720
Connector	P1701	P1802	P1803	P1701	P1901
USB0_D-	3	21	-	50	50
USB0_D+	4 ¹	22	-	48	48
USB1_D-	-	-	-	47	47
USB1_D+	-	-	-	49	49
USB_VBUS	-	-	15	52	52
UID	-	-	14	51	51

Table 63: USB Host Interface Example Bill of Materials

Designator	Manufacturer	Manufacturer Part Number
D1	On Semiconductor	ESD7L5.0DT5G
D2	Littelfuse	V5.5MLA0402NR
FB1	TDK	MMZ1005B800C
J1	Molex	0482040001
L1	Würth Electronics	744230450

¹This pin is multiplexed with the COM3 receive signal and is not available when COM3 is enabled.

F.6 Ethernet Port

OEM7 receivers, except the OEM719, provide a 10/100 Ethernet port with auto-negotiation. The Ethernet interface is disabled by default and must be configured. See the Ethernet Configuration for instructions on Ethernet device configuration. The PHY layer is based on the Texas Instruments TKL106 Ethernet PHY.

PHY terminations are provided on the OEM7 receiver card and a 3.3 V output is presented to bias the Ethernet magnetics. The 3.3 V power supplied by the OEM7 receiver card is not to be used for any purposes other than biasing the Ethernet magnetics.

A reference schematic is shown in *Figure 65: Ethernet Reference Schematic* below. The ferrite bead is included as an EMI de-risk contingency and may not be necessary.

Figure 65: Ethernet Reference Schematic

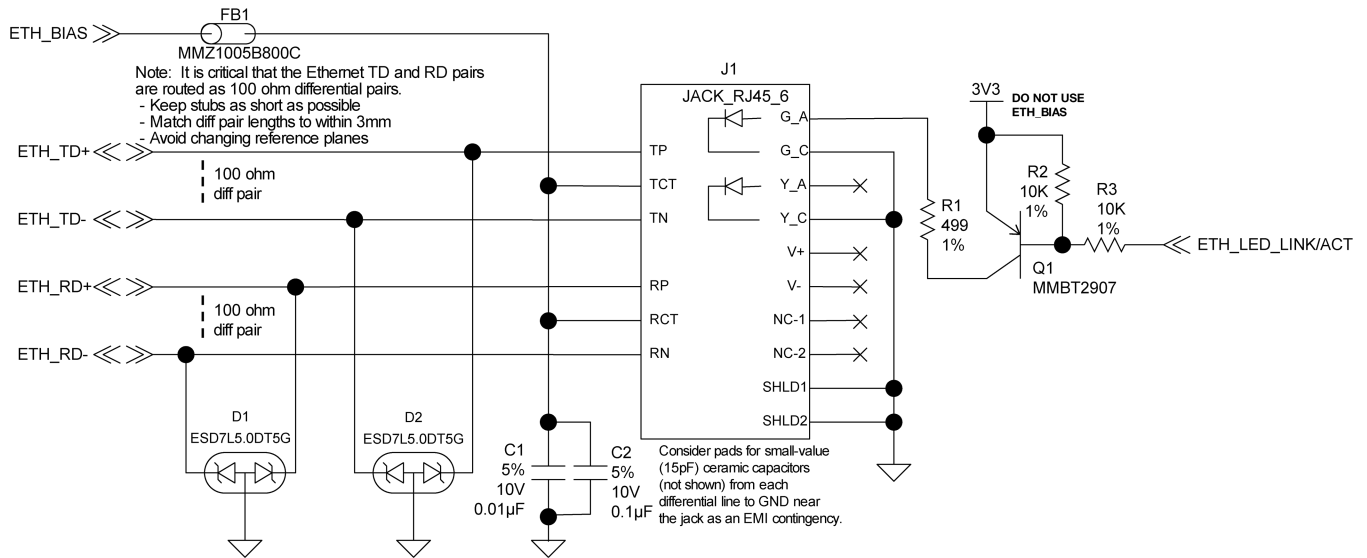

Table 64: Ethernet Pin Designation

	OEM729	OEM7600	OEM7700	OEM7720
Connector	P1803	P1701	P2001	P1901
ETH_BIAS	Receive: 3 Transmit: 6	56	56	56
ETH_TD+	4	58	58	58
ETH_TD-	5	60	60	60
ETH_RD+	2	57	57	57
ETH_RD-	1	59	59	59

Run 100 Ω differential pairs over unbroken reference planes directly to the jack. Ensure the integrated magnetics in the jack meet the specifications in *Table 65: Ethernet Transformer Characteristics* on the next page. Ensure that the jack is no more than 15 cm (6 inches) from the OEM7 connector. Shorter runs are better.

Table 65: Ethernet Transformer Characteristics

Parameter	Value	Test Condition
Turns ratio	1 CT : 1 CT	
Open-CCT inductance (minimum)	350 μ H	100 mV, 100 kHz, 8 mA
Leakage inductance (maximum)	0.4 μ H	1 MHz (minimum)
Inter-winding capacitance (minimum)	12 pF	
DC resistance (maximum)	0.9 Ω	
Insertion loss (maximum)	1.0 dB	0 MHz - 65 MHz
HIPOT (minimum)	1500 Vrms	

Table 66: Bill of Materials (critical components)

Designator	Manufacturer	Manufacturer Part Number
FB1	TDK	MMZ1005B800C
D1, D2	On Semiconductor	ESD7L5.0DT5G
J1	Wurth Electronics	7499211121A
Q1	On Semiconductor Fairchild Semiconductor	MMBT2907ALT1G MMBT2907A

APPENDIX G Importance of Antenna Selection

An antenna behaves both as a spatial and frequency filter, therefore, selecting the right GNSS antenna is critical for optimizing performance. An antenna must match the receiver's capabilities and specifications, as well as meet size, weight, environmental and mechanical specifications for the intended application.

Factors to consider when choosing a GNSS antenna include:

1. Constellation and signals

Each GNSS constellation and SBAS has its own signal frequencies and bandwidths. An antenna must cover the signal frequencies transmitted by the constellation and bandwidth supported by the GNSS receiver.

2. Antenna gain

Gain is a key performance indicator of a GNSS antenna. Gain can be defined as the relative measure of an antenna's ability to direct or concentrate radio frequency energy in a particular direction or pattern. A minimum gain is required to achieve a minimum carrier-to-power-noise ratio (C/No) to track GNSS satellites. The antenna gain is directly related to the overall C/No of the navigation GNSS receivers. Hence, antenna gain helps define the tracking ability of the system.

3. Element Gain

The element gain defines how efficient the antenna element is at receiving the signals. In any signal chain, you are only as good as the weakest link, so an antenna element with low element gain might be compensated by an increased low noise amplifier gain. However, the signal-to-noise ratio or C/No is still degraded.

4. Antenna beamwidth and gain roll-off

Gain roll-off is a factor of beamwidth, and specifies how much the gain changes over the elevation angle of the antenna. From the antenna's point of view, the satellites rise from the horizon towards zenith and fall back to the horizon. The variation in gain between zenith (directly overhead) and the horizon is known as the gain roll-off. Different antenna technologies have different gain roll-off characteristics.

5. Phase center stability

The phase center of the antenna is the point where the signals transmitted from satellites are collected. When a receiver reports a location fix, that location is essentially the phase center of the antenna.

The electrical phase center of any antenna will vary with the position of the transmitting signal it is receiving by as much as a few millimetres. As GNSS satellites move across the sky, the electrical phase center of the signal received will typically move with the satellite position unless the antenna has been carefully designed to minimize Phase Center Offset (PCO) and Phase Center Variation (PCV).

The PCO with respect to the Antenna Reference Point (ARP) is the difference between the mechanical center of antenna rotation and electrical phase center location. The PCO is also frequency dependent which means that there can be a different offset for each signal frequency. The PCV identifies how much the phase center moves with respect to the satellite elevation angles.

Figure 66: Plot of Good and Poor Antenna Phase Center Variation over Elevation Angle 0-90°

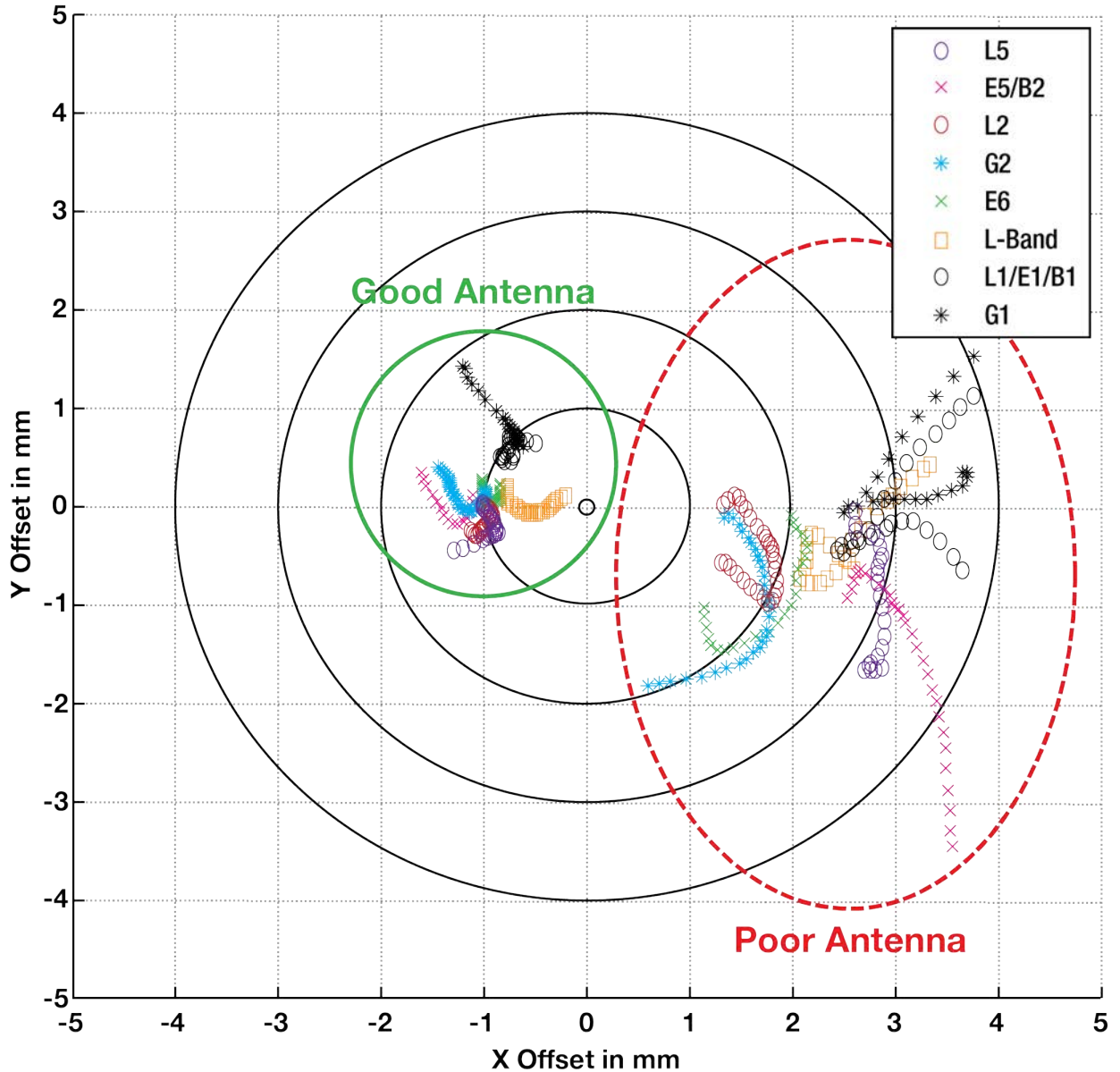

Many users can accept accuracies of less than a metre so these small phase center variations cause a negligible amount of position error. But if you require high precision, Real Time Kinematic (RTK) receivers can achieve position accuracies of 2-4 cm and a few millimetres of phase center error translates to a 10-15% error in reported position. For RTK survey applications, geodetic grade antennas offer superior PCO/PCV performance.

6. The application

An antenna has to meet the performance, environmental, mechanical, and operational requirements of the intended application. For example, GNSS antennas used for aviation applications should ideally be TSO/FAA certified and be rugged enough to handle extreme temperatures and vibration profiles. Survey rover antennas should be able to survive rough handling by surveyors including a pole drop.

The table below highlights some of the important desirable features needed for a GNSS antenna based upon the user's application.

Desirable Feature	Survey	GIS	Reference Station	Aviation/Aerial Survey	Marine	Construction/Mining	Precision Agriculture	Vehicle Tracking	Dock Operations	Unmanned Aircraft	Unmanned Vehicle	Timing
Low Profile				•		•		•		•		
Ultra-low PCO/PCV	•		•									
Low PCO/PCV		•		•		•	•			•	•	
High Vibration				•		•	•		•	•	•	
Rugged	•	•	•			•			•			
Single Frequency												•
Multi Constellation	•	•	•	•	•	•	•		•	•	•	
Multi Frequency (RTK)	•	•	•		•	•	•		•	•	•	
L-band frequency (Correction Services)					•		•					
Narrow Bandwidth												•
Weatherproof	•	•	•	•	•	•	•	•	•	•	•	•
Corrosion Resistant			•		•	•			•			•
High Multipath Suppression	•		•		•	•	•		•		•	
Pole Mount	•	•	•		•	•			•			•
Magnetic/Surface Mount						•	•	•	•		•	
TSO/FAA Certification				•						•		
Extended Temperature Range			•	•						•		
Small Form-factor/ Lightweight		•								•		
High Altitude Operation			•	•						•		

APPENDIX H Accessories and Replacement Parts

The following tables list the replacement parts available for your NovAtel OEM7 receiver. For assistance or to order additional components, contact your local NovAtel dealer or Customer Support.

Table 67: OEM7 Receivers

NovAtel Part	Part Description
OEM719	OEM7 receiver card with OEM6 compatible 20 pin header
OEM729	OEM7 receiver card with OEM6 compatible 24 pin and 16 pin headers
OEM7600	OEM7 receiver card with high density 60 pin socket and small form factor
OEM7700	OEM7 receiver card with high density 60 pin socket
OEM7720	OEM7 receiver card with dual antenna inputs and high density 60 pin socket
PwrPak7	OEM7 enclosure with Wi-Fi and built in data storage
PwrPak7D	Dual antenna OEM7 enclosure with Wi-Fi and built-in data storage
PwrPak7-E1	Single enclosure SPAN GNSS+INS receiver with EG320N IMU, Wi-Fi and built-in data storage
PwrPak7D-E1	Single enclosure SPAN GNSS+INS receiver with dual antenna inputs, EG320N IMU, Wi-Fi and built-in data storage
PwrPak7-E2	Single enclosure SPAN GNSS+INS receiver with EG370N IMU, Wi-Fi and built-in data storage
PwrPak7D-E2	Single enclosure SPAN GNSS+INS receiver with dual antenna inputs, EG370N IMU, Wi-Fi and built-in data storage
PwrPak7M	OEM7 enclosure (no Wi-Fi or data storage)
PwrPak7DM	Dual antenna OEM7 enclosure (no Wi-Fi or data storage)
PwrPak7M-E1	Single enclosure SPAN GNSS+INS receiver with an EG320N IMU (no Wi-Fi or data storage)
PwrPak7DM-E1	Single enclosure SPAN GNSS+INS receiver with dual antenna inputs and EG320N IMU (no Wi-Fi or data storage)
PwrPak7M-E2	Single enclosure SPAN GNSS+INS receiver with an EG370N IMU (no Wi-Fi or data storage)
PwrPak7DM-E2	Single enclosure SPAN GNSS+INS receiver with dual antenna inputs and EG370N IMU (no Wi-Fi or data storage)
PwrPak7Q-E2	Single enclosure SPAN GNSS+INS receiver with EG370N IMU and built-in data storage (no Wi-Fi)
PwrPak7DQ-E2	Single enclosure SPAN GNSS+INS receiver with dual antenna inputs, EG370N IMU and built-in data storage (no Wi-Fi)

NovAtel Part	Part Description
CPT7	Single enclosure SPAN GNSS+INS receiver with dual antenna inputs, HG4930 IMU and built-in data storage
CPT7700	Single enclosure SPAN GNSS+INS receiver with HG4930 IMU and built-in data storage

Table 68: GNSS Antennas

NovAtel Part	Part Description
High Performance Antennas	
GNSS-501	GPS L1, GLONASS L1, BeiDou B1, Galileo E1 and L-Band
GNSS 502	GPS L1/L2, GLONASS L1/L2, BeiDou B1/B2b, Galileo E1/E5b and L-Band
GNSS-802	GPS L1/L2, GLONASS L1/L2, BeiDou B1 and Galileo E1
GNSS-802L	GPS L1/L2, GLONASS L1/L2, BeiDou B1, Galileo E1 and L-Band
GNSS-804	GPS L1/L2, GLONASS L1/L2, BeiDou B1/B2b and Galileo E1/E5b
GNSS-804L	GPS L1/L2, GLONASS L1/L2, BeiDou B1/B2b, Galileo E1/E5b and L-Band
GNSS-850	GPS L1/L2/L5, GLONASS L1/L2/L3, BeiDou B1/B2a/B2b/B3, Galileo E1/E5a/E5b/E6 and L-Band
Compact Antennas	
2G15A-XTB-1	2.6" circular form factor (GPS L1)
3G15A-XT-1	3.5" circular form factor (GPS L1)
42G1215A-XT-1	ARINC-743 bolt pattern (GPS L1/L2)
G5Ant-42AT1	ARINC-743 bolt pattern (GPS L1/L2, GLONASS L1/L2 and L-Band)
3GNSSA-XT-1	3.5" circular form factor (GPS L1/L2/L5, GLONASS L1/L2, BeiDou B1/B2a/B2b/B3, Galileo E1/E5a/E5b/E6, NavIC L5 and L-Band)
42GNSSA-XT-1	ARINC-743 bolt pattern (GPS L1/L2/L5, GLONASS L1/L2, BeiDou B1/B2a/B2b/B3, Galileo E1/E5a/E5b/E6, NavIC L5 and L-Band)
5BE-225-500-XT-1	Blade form factor (UHF 255 – 500 MHz)
G3Ant-2A196MNS-4	2.7" circular form factor (GPS L1, GLONASS L1, L-Band)
G3Ant-42A4T1	ARINC-743 bolt pattern (GPS L1, GLONASS L1, L-Band)

Table 69: GNSS Antenna Cables

NovAtel Part	Part Description
GPS-C006	5 metres – TNC to TNC cable
GPS-C016	15 metres – TNC to TNC cable
GPS-C032	30 metres – TNC to TNC cable
60723177	2.5 metres – SMA to TNC cable
60723178	5 metres – SMA to TNC cable

Table 70: Receiver Card Mounting Accessories

NovAtel Part	Part Description
01019750	7 mm rail for OEM719, OEM7700 and OEM7720
01019751	10 mm rail for OEM719, OEM7700 and OEM7720
01019752	12 mm rail for OEM719
01020014	OEM7720 Accessory Heat Spreader

H.1 Manufacturers' Part Numbers

The following original manufacturer's part numbers are provided for information only and are not available from NovAtel as separate parts.

Product	Part Description	Part Number
OEM719 <i>Figure 13: OEM719 Connector and Indicator Locations on page 41</i>	J201, MCX jack receptacle	Johnson 133-3711-202 Samtec MCX-J-P-H-ST-SM1
	P1701, 2 x 10 header, 2 mm pitch	Samtec TMM-110-03-G-D
OEM729 <i>Figure 14: OEM729 Connector and Indicator Locations on page 42</i>	J201 & J1901, MMCX jack receptacle	Johnson 135-3701-201 Samtec RSP-149374-01
	P1802, 2x12 header, 2 mm pitch	Samtec TMM-112-03-G-D
	P1803, 2x8 header, 2 mm pitch	Samtec TMM-108-03-G-D
OEM7600 <i>OEM7600 Connector and Indicator Locations on page 43</i>	J201, MMCX right angle jack receptacle	Shen Zhen Superlink 5MCF25R-P41-009
	P1701, 60 pin connector	Samtec ASP-189258-01
OEM7700 <i>(Figure 16: OEM7700 Connector and Indicator Locations on page 44)</i>	J201, MMBX jack receptacle	HUBER + SUHNER 82_MMBX-S50-0-1/111 NE
	P2001, 60 pin connector	Samtec ASP-189258-01

Product	Part Description	Part Number
OEM7720 <i>Figure 16: OEM7700 Connector and Indicator Locations on page 44</i>	J201 & J501, MMBX jack receptacle	HUBER + SUHNER 82_MMBX-S50-0-1/111 NE
	P1901, 60 pin connector	Samtec ASP-189258-01



See *Table 2: OEM7 Communication and I/O Connectors* on page 40 for the part number of the mating connector for P2001 and P1901.

H.1 USB Devices Supported

The embedded USB host systems on OEM7 receivers supports a limited number of USB devices. These devices are defined in the Targeted Peripheral List (TPL). *Table 71: Targeted Peripheral List for OEM7 USB Embedded Host* below shows the targeted peripheral list for the host-capable OEM7 receivers (OEM7600, OEM7700, OEM7720, PwrPak7).

Table 71: Targeted Peripheral List for OEM7 USB Embedded Host

Class Name	Class Code	Sub Class Code	Protocol	Speed Supported
Hub	09h	0	1	High
Mass Storage	08h	06h (SCSI transparent command set)	50h (Bulk-Only Transport)	High

The devices in the following table have been tested by NovAtel and confirmed to be compatible with the USB host system on OEM7 receivers.

Table 72: Devices Tested for OEM7 USB Embedded Host

Class Type	Manufacturer	Model	Vendor ID	Product ID	Description	Speed
Hub	D-Link/Genesys Logic	DUB-7	05E3h	0608h	7 Port Hub 2.0	High
Mass Storage	Kingston Technology	DataTraveler 3.0	0951h	6609h	Kingston 32GB	High
Mass Storage	Kingston Technology	DataTraveler 2.0	0951h	1665h	Kingston 32GB	High
Mass Storage	Toshiba Corporation	DataTraveler 2.0	0930h	6545h	DTSE9 8GB	High
Mass Storage	Silicon Motion Technology	Teclast CoolFlash	090Ch	1000h	GHS 32GB	High
Mass Storage	Sony Corporation	Storage Media	054Ch	09C2h	Sony 8GB	High

H.1.1 Restrictions on connecting mass storage devices

- The mass storage device should not contain more than 4194304 clusters. For large capacity devices, format them with a larger allocation unit size to reduce the number of clusters.
- If the mass storage device has multiple partitions, only the first partition is mounted and used.
- If multiple mass storage devices are connected to the USB port, only the first connected device is mounted and used.
- If multiple mass storage devices are connected to the USB port during boot up, there is no way to predict which device is mounted and used.

APPENDIX I Electrostatic Discharge (ESD) Practices

Various electrical and electronic components are vulnerable to ESD. These include discrete components, hybrid devices, Integrated Circuits (ICs) and Printed Circuit Boards (PCBs) assembled with these devices.

I.1 Handling ESD Sensitive Devices

ESD sensitive devices must only be handled in static controlled locations. Some recommendations for such handling practices follow:

- Handling areas must be equipped with a grounded table, floor mats and wrist strap.
- A relative humidity level must be maintained between 20% and 80% non-condensing.
- No ESD sensitive board or component should be removed from its protective package, except in a static controlled location.
- A static controlled environment and correct static control procedures are required at both repair stations and maintenance areas.
- ESD sensitive devices must be handled only after personnel have grounded themselves via wrist straps and mats.
- Boards or components should never come in contact with clothing, because normal grounding cannot dissipate static charges on fabrics.
- A circuit board must be placed into a static shielding bag or clamshell before being removed from the work location and must remain in the protective enclosure until it arrives at a static controlled repair/test center.
- Circuit boards must not be changed or moved needlessly. Handles may be provided on circuit boards for use in their removal and replacement; care should be taken to avoid contact with the connectors and components.
- On-site repair of ESD sensitive equipment should not be undertaken except to restore service in an emergency where spare boards are not available. Under these circumstances repair station techniques must be observed. Under normal circumstances a faulty or suspect circuit board must be sent to a repair center having complete facilities or to the manufacturer for exchange or repair.
- Where protective measures have not been installed, a suitable alternative would be the use of a Portable Field Service Grounding Kit (for example, 3M Kit #8501 or #8507). This consists of a portable mat and wrist strap which must be attached to a suitable ground.
- A circuit board in a static shielding bag or clamshell may be shipped or stored in a cardboard carton, but the carton must not enter a static controlled area such as a grounded or dissipative bench top or repair zone. Do not place anything else inside the bag (for example, repair tags).
- Treat all PCBs and components as ESD sensitive. Assume that you will damage the PCB or component if you are not ESD conscious.
- Do not use torn or punctured static-shielding bags. A wire tag protruding through the bag could act as a "lightning rod", funneling the entire charge into the components inside the bag.
- Do not allow chargeable plastics, such as binders, within 0.6 m of unshielded PCBs.
- Do not allow a PCB to come within 0.3 m of a computer monitor.

I.2 Prime Static Accumulators

Table 73: Static-Accumulating Materials on the next page provides some background information on static accumulating materials.

Table 73: Static-Accumulating Materials

Work Surfaces	<ul style="list-style-type: none"> • formica (waxed or highly resistive) • finished wood • synthetic mats • writing materials, note pads and so on
Floors	<ul style="list-style-type: none"> • wax-finished • vinyl
Clothes	<ul style="list-style-type: none"> • common clean room smocks • personal garments (all textiles) • non-conductive shoes
Chairs	<ul style="list-style-type: none"> • finished wood • vinyl • fiberglass
Packing and handling	<ul style="list-style-type: none"> • common polyethylene bags, wraps, envelopes and bubble pack • pack foam • common plastic trays and tote boxes
Assembly, cleaning and repair areas	<ul style="list-style-type: none"> • spray cleaners • vacuum desoldering iron • common soldering irons • common solvent brushes (synthetic bristles) • cleaning, drying and temperature chambers

I.3 Handling Printed Circuit Boards

ESD damage to unprotected sensitive devices may occur at any time. ESD events can occur far below the threshold of human sensitivity. Follow this sequence when it becomes necessary to install or remove a circuit board:

1. After you are connected to the grounded wrist strap, remove the circuit board from the frame and place it on a static controlled surface (grounded floor or table mat).
2. Remove the replacement circuit board from the static-shielding bag or clamshell and insert it into the equipment.
3. Place the original board into the shielding bag or clamshell and seal it with a label.
4. Do not put repair tags inside the shielding bag or clamshell.
5. Disconnect the wrist strap.

