



HEXAGON



**CPT7 and CPT7700
Installation and Operation
User Manual**

CPT7 and CPT7700 Installation and Operation User Manual

Publication Number: D100409

Revision Level: v4

Revision Date: February 2026

Firmware Version: CPT7 7.10.00 / SC7PR1000RN0000

Warranty

NovAtel Inc. warrants that its GNSS products are free from defects in materials and workmanship, subject to the conditions set forth on our web site: novatel.com/products/novatel-warranty-and-return-policies.

Return instructions

To return products, refer to the instructions found at: novatel.com/products/novatel-warranty-and-return-policies.

Proprietary notice

This document and the information contained herein are the exclusive properties of the legal entities that comprise the Autonomous Solutions division of the Hexagon AB group of companies (“Hexagon”).

No part of this document may be reproduced, displayed, distributed, or used in any medium, in connection with any other materials, or for any purpose without prior written permission from Hexagon. Applications for permission may be directed to contact.ap@hexagon.com. Unauthorized reproduction, display, distribution or use may result in civil as well as criminal sanctions under the applicable laws. Hexagon aggressively protects and enforces its intellectual property rights to the fullest extent allowed by law.

This document and the information contained herein are provided AS IS and without any representation or warranty of any kind. Hexagon disclaims all warranties, express or implied, including but not limited to any warranties of merchantability, non-infringement, and fitness for a particular purpose. Nothing herein constitutes a binding obligation on Hexagon.

The information contained herein is subject to change without notice.

ALIGN, GLIDE, Inertial Explorer, NovAtel, OEM7, RTK ASSIST, SPAN, STEADYLINE, TerraStar, VEXXIS and Waypoint are trademarks of Hexagon AB and/or its subsidiaries and affiliates, and/or their licensors. All other trademarks are properties of their respective owners.

© Copyright 2018 – 2026 Hexagon AB and/or its subsidiaries and affiliates. All rights reserved.

Table of contents

Figures

Tables

CPT7 notices

Customer Support

Chapter 1 CPT7 overview

1.1 CPT7 connectors	22
1.2 CPT7 LEDs	23
1.3 Fundamentals of GNSS+INS	25

Chapter 2 CPT7 installation

2.1 Shipping box	27
2.2 Additional equipment required	27
2.3 Optional accessories	27
2.4 CPT7 cables	27
2.5 Selecting a GNSS antenna	28
2.6 Choosing a coaxial cable	29
2.7 Power supply requirements for the CPT7	29
2.8 CPT7 installation overview	30
2.9 Mounting the GNSS antenna	33
2.9.1 Antenna LNA power	33
2.10 Mount the CPT7	34
2.10.1 Securing the CPT7	35
2.10.2 Secure the CPT7 using the adapter plate	35
2.11 Connect the CPT7 to data communication equipment	38
2.11.1 Serial ports	38
2.11.2 USB ports	39
2.11.3 Ethernet port	39
2.11.4 CAN bus port	39
2.12 Connect I/O signals to the CPT7	40
2.13 Connect power to the CPT7	40
2.13.1 Fuse for the power supply	41
2.13.2 Vehicle installation	41
2.14 Check that the CPT7 is operating	42

Chapter 3 OEM7 receiver operation

3.1 Communications with the receiver	44
3.1.1 USB communications	45
3.1.2 Serial port communications	45
3.1.3 Ethernet communications	47
3.1.4 ICOM communications	47
3.1.5 CAN bus communications	48

3.2	Getting started	48
3.2.1	Communicating with the receiver	48
3.3	Transmitting and receiving corrections	49
3.3.1	Defining antenna and base antenna	51
3.3.2	Base station configuration	51
3.3.3	Rover station configuration	52
3.3.4	Configuration notes	53
3.4	GLIDE	53
3.4.1	Dual-frequency GLIDE	54
3.4.2	PDP and GLIDE configurations	54
3.5	STEADYLINE	54
3.5.1	Prefer Accuracy	55
3.6	Enabling SBAS positioning	55
3.7	Enabling Corrections Services and PPP	56
3.7.1	TerraStar Corrections Services	56
3.7.2	Oceanix Corrections Services	60
3.7.3	Veripos Corrections Services	62
3.8	RTK ASSIST Services	63
3.9	Precision Time Protocol	63
3.9.1	Configuring PTP	64
3.9.2	Configuration notes	64
3.9.3	Monitoring the PTP status	65
3.9.4	Troubleshooting	65
3.10	Transferring time between receivers	65
3.10.1	GPS to receiver time synchronization	65
3.10.2	Time definitions	65
3.10.3	Procedures to transfer time	66
3.11	Interference Toolkit	70
3.11.1	Monitoring GNSS signals	70
3.11.2	Disable/Enable detection	72
3.11.3	Monitoring signals using the command line	72
3.11.4	Monitoring signals using NovAtel Application Suite	73
3.11.5	Remove interference signals	73
3.11.6	Interference Toolkit commands and logs	74
3.12	Logging and retrieving data overview	75
3.12.1	Pass-through logging	75
3.12.2	Saving logs to a file	75
3.12.3	Logging to internal memory	76
3.12.4	Access CPT7 internal memory with a computer	77
3.12.5	Repair errors on the CPT7 internal memory	78
3.12.6	Logging using NovAtel Application Suite or Manage Web	79
3.13	Additional features and information	79
3.13.1	Strobes	79

Chapter 4 SPAN operation

4.1	Definition of reference frames within SPAN	80
4.1.1	Local-level frame (ENU)	80
4.1.2	IMU body frame	81

4.1.3	Vehicle frame	82
4.1.4	User output frame	82
4.2	SPAN translations and rotations	82
4.2.1	Translational offsets	83
4.2.2	Rotational offsets	84
4.2.3	Output location for logs	86
4.3	Vibration considerations	88
4.3.1	Sources of error	88
4.3.2	Mitigation methods	88
4.3.3	Additional notes	89
4.4	Software configuration	89
4.4.1	GNSS configuration	89
4.4.2	INS Profiles	89
4.4.3	Configure the CPT7 IMU data rate	91
4.4.4	SPAN configuration for CPT7	92
4.4.5	Importance of lever arms	95
4.4.6	Importance of RBV calibration	97
4.4.7	Importance of antenna location for ALIGN	98
4.5	Real-time operation	99
4.5.1	System start-up and alignment techniques	100
4.5.2	INS Seed / Fast INS initialization	104
4.5.3	Navigation mode	106
4.5.4	Data collection	106
4.5.5	Recommended messages to be logged for SPAN data collection	108
4.5.6	Body to vehicle frame rotation calibration routine	109
4.5.7	Multi-line body to vehicle frame rotation calibration routine	110
4.6	Distance Measurement Instrument	112
4.6.1	DMI communication	112
4.6.2	DMI connection	112
4.6.3	DMI requirements	112
4.6.4	DMI connected to a CPT7	114
4.6.5	DMI command compatibility	115
4.6.6	DMI troubleshooting	116
4.7	Synchronizing external equipment	116
4.7.1	Configuring an input strobe	117
4.8	Adding timed sensor triggers	117
4.8.1	Configuring the hardware	118
4.8.2	Configuring the software	118
4.8.3	Using timed event pulses	118
4.8.4	Recording incoming sensor events	118
4.9	Azimuth sources on a SPAN system	118
4.9.1	Course over ground	119
4.9.2	Inertial azimuth	119
4.9.3	ALIGN azimuth	119
4.10	Data collection for post processing	120
4.11	Variable Lever Arm	121
4.11.1	Reference frame description	122
4.11.2	Example gimbal installation	122

4.11.3	How to use Variable Lever Arm	124
4.12	Relative INS	125
4.12.1	Configure Relative INS	126
Chapter 5 CPT7 with dual antenna		
5.1	Installation	128
5.2	Configuring dual antenna ALIGN with SPAN	130
5.2.1	Setup and configuration	130
5.2.2	Optional HEADINGOFFSET configuration	131
Chapter 6 Ethernet configuration		
6.1	Required hardware	133
6.2	Static IP address configuration	133
6.2.1	Static IP address configuration—receiver	134
6.2.2	Static IP address configuration—Windows 7	135
6.2.3	Confirming Ethernet setup	136
6.3	Dynamic IP address configuration	136
6.4	Base/rover configuration through Ethernet connectivity	137
6.5	Large Ethernet port data throughput	138
Chapter 7 NTRIP configuration		
7.1	NTRIP configuration over Ethernet	139
Chapter 8 CAN bus		
8.1	Default configuration	142
8.2	Configuring the CAN bus	143
8.2.1	Configuration notes	143
8.2.2	Example of enabling the CAN bus	143
8.2.3	Example of modifying the CAN bus parameters	143
8.2.4	Example of detecting an address claim failure and reconfiguring	144
8.2.5	Address claim procedure	144
8.3	NMEA2000 logging	144
8.3.1	Example of NMEA2000 log configuration	145
8.4	Corrections over CAN	145
8.4.1	Example for receiving corrections from any source	146
8.4.2	Example for transmitting corrections to 0x1C node	146
8.5	NovAtel messages over CAN	146
8.6	Configuring OEM7 receivers to use OEM6 CAN settings	146
8.6.1	Configuration on OEM6	147
8.6.2	Configuration on OEM7	147
Chapter 9 Built-In Status Tests		
9.1	Receiver status word	148
9.2	RXSTATUSEVENT log	148
9.3	RXSTATUS log	149
9.3.1	Status word	149
9.3.2	Error word	149

9.3.3	Status code arrays	150
9.3.4	Receiver status code	151
9.3.5	Auxiliary status codes	151
9.3.6	Set and clear mask for all status code arrays	151

Chapter 10 Receiver Features: Authorization and Subscriptions

10.1	Serial Number, Hardware Version, Software Model, Firmware Version	152
10.2	Authorization code	153
10.2.1	Applying a Software Model with an auth-code	153

Chapter 11 NovAtel firmware

11.1	Firmware updates	156
11.1.1	Firmware updates	156
11.1.2	Firmware downgrades	156
11.2	Downloading firmware files	156
11.2.1	Format of firmware files	156
11.3	Updating the firmware using the WinLoad utility	157
11.3.1	Open a file to download	157
11.3.2	Communications settings	158
11.3.3	Downloading firmware	159
11.4	Updating the firmware using NovAtel Application Suite	159
11.5	Updating the firmware using Manage Web	160
11.6	Updating using SoftLoad commands	160
11.6.1	Implementing SoftLoad	160
11.6.2	Use SoftLoad Customer Support utilities	161
11.6.3	Self-implement the SoftLoad process	166
11.7	Update Manage Web	171
11.7.1	Update Manage Web content using NovAtel Application Suite	171
11.7.2	Update Manage Web content using Manage Web	171

Chapter 12 Troubleshooting

12.1	Examining the RXSTATUS log	174
12.2	Examining the AUX1 status word	177
12.3	High temperature environments	179
12.3.1	Indicators of an error state	179
12.3.2	Recovering from a temperature status error	179
12.3.3	Mitigating high receiver temperature	179
12.3.4	Monitoring the receiver temperature	180
12.4	Safe Mode	181
12.4.1	Reset loop detection	181
12.4.2	Recovery steps	181

Appendix A CPT7 technical specifications

A.1	CPT7 performance specifications	183
A.2	CPT7700 performance specifications	186
A.3	CPT7 IMU performance specifications	189
A.4	CPT7 mechanical specifications	190

A.5 CPT7 electrical and environmental specifications	195
A.6 CPT7 data communication specifications	198
A.7 CPT7 strobe specifications	199
A.8 CPT7 connectors	200
A.9 CPT7 I/O1 cable	202
A.9.1 Custom cable recommendations	203
A.10 CPT7 I/O2 cable	204
A.10.1 Custom cable recommendations	205

Appendix B Differences between CPT7 and Legacy CPT7

Appendix C Accessories and replacement parts

Appendix D Frequently asked questions

Appendix E Importance of antenna selection

Figures

- Figure 1: CPT7 receiver 22
- Figure 2: CPT7700 receiver 22
- Figure 3: CPT7 status indicators 24
- Figure 4: Typical installation of a CPT7 system 31
- Figure 5: Typical installation of a CPT7700 system 32
- Figure 6: Default RBV configuration 34
- Figure 7: CPT7 adapter plate 36
- Figure 8: Offset from the CPT7 to the SPAN-CPT 37
- Figure 9: Offset from the CPT7 to the SPAN-IGM-S1 38
- Figure 10: Fuse for CPT7 power supply 41
- Figure 11: Dedicated battery for the CPT7 42
- Figure 12: Basic CPT7 connection interfaces (example) 44
- Figure 13: Basic differential setup 50
- Figure 14: Positioning Change Without STEADYLINE 55
- Figure 15: STEADYLINE Prefer Accuracy 55
- Figure 16: Transfer COARSE time from Fine clock to Cold clock receiver 67
- Figure 17: Transfer FINE time from Fine clock to Cold clock receiver 68
- Figure 18: Transfer FINE time from Fine clock to Warm clock receiver 69
- Figure 19: 1 PPS alignment 69
- Figure 20: Local-level frame (ENU) 81
- Figure 21: IMU body frame marking 81
- Figure 22: Vehicle frame 82
- Figure 23: IMU to antenna translation offset 83
- Figure 24: CPT7 to antenna offset 93
- Figure 25: Antenna lever arm – total station 96
- Figure 26: Antenna lever arm – tape measure 97
- Figure 27: Rear view of CPT7 – mounting plate is not flat 97
- Figure 28: Side view of CPT7 – vehicle is not level 98
- Figure 29: Top view of CPT7 – CPT7 misalignment 98
- Figure 30: Multi-line IMU body to vehicle calibration 110
- Figure 31: Kistler WPT 113
- Figure 32: DMI to CPT7 setup 114
- Figure 33: Sample configuration 123
- Figure 34: Operating gimbal 123

Figure 35: Relative INS example	126
Figure 36: SPAN – CPT7700 dual antenna installation	129
Figure 37: SPAN – CPT7 dual antenna installation	130
Figure 38: Cross-over Ethernet cable configuration—OEM7 receiver	134
Figure 39: Dynamic IP address configuration through a DHCP server—OEM7 receiver	136
Figure 40: Base/rover Ethernet setup—OEM7 receiver	137
Figure 41: NTRIP system	139
Figure 42: Location of receiver status word	149
Figure 43: Reading the bits in the receiver status word	149
Figure 44: Location of receiver error word	150
Figure 45: Reading the bits in the receiver error word	150
Figure 46: Status code arrays	151
Figure 47: WinLoad's Open Window	157
Figure 48: Open File in WinLoad	158
Figure 49: COM Port Setup	158
Figure 50: CPT7 dimensions	191
Figure 51: CPT7700 dimensions	192
Figure 52: CPT7/CPT7700 alignment holes	193
Figure 53: CPT7/CPT7700 centre of navigation	194
Figure 54: Fischer Core 16 pin connector	200
Figure 55: CPT7 I/O1 cable	202
Figure 56: CPT7 I/O2 cable	204
Figure 57: Plot of good and poor antenna phase centre variation over elevation angle 0-90°	214

Tables

Table 1: CPT7 connectors	23
Table 2: CPT7 and CPT7700 status indicators	24
Table 3: PWR (Power) LED	24
Table 4: POS (Positioning) LED	24
Table 5: INS LED	25
Table 6: LOG (onboard storage) LED	25
Table 7: CPT7 cables	28
Table 8: Fuse/Holder recommendations	41
Table 9: Serial ports supported	46
Table 10: Output location and frame for logs	86
Table 11: OEM7 INS Profiles	89
Table 12: Inertial solution status	100
Table 13: NVM seed indication	106
Table 14: Solution parameters	106
Table 15: Kistler to NovAtel wheel sensor cable connections	113
Table 16: DMI command and log compatibility	115
Table 17: Valid event inputs and outputs for timed sensor triggers	118
Table 18: Logs with azimuth data	119
Table 19: Logs used with Variable Lever Arm	124
Table 20: Commands used with Variable Lever Arm	125
Table 21: Default NAME	142
Table 22: Troubleshooting based on symptoms	173
Table 23: Resolving a receiver error word	174
Table 24: Resolving an error in the receiver status word	175
Table 25: Resolving an error in the AUX1 status word	177
Table 26: RF paths for OEM7 receivers	178
Table 27: CPT7 physical description	182
Table 28: CPT7 receiver performance	183
Table 29: CPT7700 receiver performance	186
Table 30: CPT7 IMU performance	189
Table 31: CPT7 environmental specifications	195
Table 32: CPT7 power requirements	195
Table 33: CPT7 RF input/LNA power output	195
Table 34: CPT7 wheel sensor input signal levels	196

Table 35: Data communications interfaces	198
Table 36: CPT7 strobes description	199
Table 37: CPT7 strobe electrical specifications	199
Table 38: IO1 pinout	200
Table 39: IO2 pinout	201
Table 40: CPT7 I/O1 cable pinout	202
Table 41: I/O1 Connector	203
Table 42: CPT7 I/O2 cable pinout	204
Table 43: IO2 connector	205
Table 44: Physical specifications	206
Table 45: Power requirements	206
Table 46: Signals tracked	206
Table 47: RF input	207
Table 48: COM port communication	208
Table 49: I/O strobes	208
Table 50: Features	208
Table 51: OEM7 receivers	209
Table 52: GNSS antennas	210
Table 53: CPT7 cables	211
Table 54: GNSS antenna cables	211
Table 55: CPT7 mounting accessories	211

CPT7 notices

The following notices apply to the CPT7 and CPT7700.



Changes or modifications to this equipment, not expressly approved by NovAtel Inc., could void the user's authority to operate this equipment.

FCC

The devices covered by this manual comply with part 15 of the FCC Rules. Operation is subject to the following two conditions: (1) this device may not cause harmful interference, and (2) this device must accept any interference received, including interference that may cause undesired operation.

The equipment listed has been tested and found to comply with the limits for a Class B digital device, pursuant to part 15 of the FCC Rules. The Class B limits are designed to provide reasonable protection against harmful interference in a residential installation. The equipment listed generates, uses, and can radiate radio frequency energy and, if not installed and used in accordance with the instructions, may cause harmful interference to radio communications. However, there is no guarantee that interference will not occur in a particular installation. If this equipment does cause harmful interference to radio or television reception, which can be determined by turning the equipment off and on, the user is encouraged to try to correct the interference by one or more of the following measures:

- Reorient or relocate the receiving antenna
- Increase the separation between the equipment and the receiver
- Connect the equipment to an outlet on a circuit different from that to which the receiver is connected
- Consult the dealer or an experienced radio/TV technician for help



To maintain compliance with the limits of a Class B digital device, you must use shielded interface cables.

Innovation, Science and Economic Development (ISED) Canada

CPT7 Class B digital device complies with Canadian ICES-003.

CPT7 appareils numérique de la classe B sont conforme à la norme NMB-003 du Canada.

European Union (EU) / United Kingdom (UK)

NovAtel Inc. declares that the CPT7 GNSS receiver is in compliance with:

1. EU Directive 2014/53/EU
2. UK Regulations S.I. 2017/1206

The full text of the EU Declaration of Conformity may be obtained from the NovAtel website at:

novatel.com/products/novatel-compliance.

WEEE

If you purchased your CPT7 in Europe or the United Kingdom, please return it to your dealer or supplier at the end of life. The objectives of NovAtel's environment policy are, in particular, to preserve, protect and improve the quality of the environment, protect human health and utilise natural resources prudently and rationally. Sustainable development advocates the reduction of wasteful consumption of natural resources and the prevention of pollution. Waste Electrical and Electronic Equipment (WEEE) is a regulated area. Where the generation of waste cannot be avoided, it should be reused or recovered for its material or energy. WEEE

products may be recognized by their wheeled bin label ()

See novatel.com/products/novatel-compliance/novatel-environmental-compliance for more information.

RoHS

CPT7 GNSS receivers are in conformity with:

1. Directive 2011/65/EU of the European Parliament and of the council of 8 June 2011 on the restriction of the use of certain hazardous substances in electrical and electronic equipment.
2. the Restriction of the Use of Certain Hazardous Substances in Electrical and Electronic Equipment (Amendment) Regulations 2012 (S.I. 2012/3032).

CPT7 international approval

Eurasian Economic Community

Armenia, Belarus, Kazakhstan, Kyrgyzstan and Russia



Conventions

The following conventions are used in this manual:



Information that supplements or clarifies text.



A caution that actions, operation or configuration may lead to incorrect or improper use of the hardware.



A warning that actions, operation or configuration may result in regulatory noncompliance, safety issues or equipment damage.



Identifies content that is specific to receivers using 7.09.xx firmware.



Identifies content that is specific to receivers using 7.10.xx firmware.

Customer Support

NovAtel knowledge base

If you have a technical issue, visit the NovAtel Support page at novatel.com/support. Through the *Support* page you can contact Customer Support, find papers and tutorials or download the latest firmware. To access the latest user documentation, visit docs.novatel.com/OEM7.

Before contacting Customer Support

Before contacting NovAtel Customer Support about a software problem, perform the following steps:



If logging data over an RS-232 serial cable, ensure that the configured baud rate can support the data bandwidth (see **SERIALCONFIG** command). NovAtel recommends a minimum suggested baud rate of 230400 bps.

1. Use the information in the *Troubleshooting* on page 173 section to diagnose and troubleshoot your receiver's symptoms.
2. Log the data suggested in the appropriate *Troubleshooting Logs* section to a file on your computer for 15 minutes.
 - *General troubleshooting logs* on the next page
 - *Tracking and interference troubleshooting logs* on the next page
 - *SPAN troubleshooting logs* on page 18
 - *RTK troubleshooting logs* on page 18
 - *PPP troubleshooting logs* on page 19
 - *ALIGN troubleshooting logs* on page 20

If using NovAtel Application Suite, log the Troubleshooting message set for 15 minutes.

3. Send the data file to NovAtel Customer Support: support.novatel@hexagon.com
4. You can also issue a **FRESET** command to the receiver to clear any unknown settings.



The **FRESET** command will erase all user settings. You should know your configuration (by requesting the RXCONFIGA log) and be able to reconfigure the receiver before you send the **FRESET** command.

If you are having a hardware problem, send a list of the troubleshooting steps taken and the results.

Contact information

Log a support request with NovAtel Customer Support using one of the following methods:

Log a case and search knowledge:

Website: novatel.com/support

Log a case, search knowledge and view your case history: (login access required)

Web Portal: shop.novatel.com/novatelstore/s/contactsupport

E-mail:

support.novatel@hexagon.com

Telephone:

U.S. and Canada: 1-800-NOVATEL (1-800-668-2835)

International: +1-403-295-4900

General troubleshooting logs

```
LOG RXSTATUSB ONCHANGED
LOG RAWEPHEMB ONNEW
LOG GLORAWEPHEMB ONNEW
LOG BESTPOSB ONTIME 1
LOG RANGE B ONTIME 0.5
LOG RXCONFIGA ONCE
LOG VERSIONA ONCE
LOG LOGLISTA ONCE
LOG PORTSTATSA ONTIME 10
LOG PROFILEINFOA ONCE
LOG HWMONITORA ONTIME 10
```

Tracking and interference troubleshooting logs

```
LOG VERSIONA ONCE
LOG RXCONFIGA ONCE
LOG CHANCONFIGLISTB ONCE
LOG PASSTHROUGHHA ONNEW
LOG RXSTATUSB ONCHANGED
LOG CLOCKSTEERINGB ONCHANGED
LOG RAWEPHEMB ONNEW
LOG GLORAWEPHEMB ONNEW
LOG GALINAVRAWEPHEMERISB ONNEW
LOG BDSEPEHEMERISB ONNEW
LOG QZSSEPEHEMERISB ONNEW
LOG NAVICEPEHEMERISB ONNEW
LOG RAWALMB ONNEW
LOG GLORAWALMB ONNEW
LOG GALALMANACB ONNEW
LOG BDSALMANACB ONNEW
LOG QZSSALMANACB ONNEW
LOG NAVICALMANACB ONNEW
LOG IONUTC B ONNEW
LOG GLOCLOCKB ONNEW
LOG GALCLOCKB ONNEW
LOG BDSCLOCKB ONNEW
LOG TRACKSTATB ONTIME 1
LOG RANGE B ONTIME 0.5
LOG BESTPOSB ONTIME 1
LOG SATVIS2B ONTIME 30
LOG ITDETECTSTATUSB ONCHANGED
```

For dual antenna receivers, add these logs:

```
LOG TRACKSTATB_1 ONTIME 1
LOG RANGE_B_1 ONTIME 0.5
```

For interference issues add this log:

```
LOG ITPSDDETECTB ONNEW
```

For interference issues, when you have enough datalink bandwidth to handle large logs, add this log:

```
LOG ITPSDFINALB ONNEW
```

SPAN troubleshooting logs

```
LOG RXSTATUSB ONCHANGED
LOG RAWEPHEMB ONNEW
LOG GLORAWEPHEMB ONNEW
LOG GALINAVRAWEPHEMERISB ONNEW
LOG BDSEPHEMERISB ONNEW
LOG BESTPOSB ONTIME 1
LOG RANGE_B ONTIME 0.5
LOG RXCONFIGA ONCE
LOG VERSIONA ONCE
LOG RAWIMUSXB ONNEW
LOG INSUPDATESTATUSB ONCHANGED
LOG INSPVAXB ONTIME 1
LOG INSCONFIGA ONCHANGED
LOG BESTGNSSPOSB ONTIME 1
```

RTK troubleshooting logs

```
LOG RXSTATUSB ONCHANGED
LOG RAWEPHEMB ONNEW
LOG GLORAWEPHEMB ONNEW
LOG QZSSRAWEPHEMB ONNEW
LOG BDSRAWNAVSUBFRAMEB ONNEW
LOG GALFNAVRAWEPHEMERISB ONNEW
LOG GALINAVRAWEPHEMERISB ONNEW
LOG RANGE_B ONTIME 0.5
LOG BESTPOSB ONTIME 1.0
LOG RXCONFIGB ONCE
LOG VERSIONB ONCE
LOG TRACKSTATB ONTIME 1.0
LOG RTKPOSB ONTIME 1.0
LOG MATCHEDPOSB ONNEW
LOG MATCHEDSATS ONNEW
LOG RTKSATS ONTIME 1.0
LOG PSRPOSB ONTIME 1.0
LOG RAWALMB ONNEW
LOG IONUTCB ONNEW
LOG GLORAWALMB ONNEW
LOG GLOCLOCKB ONNEW
LOG PASSTHROUGHB ONNEW
LOG CLOCKMODEL ONTIME 1.0
LOG REFSTATIONB ONNEW
LOG RTKVELB ONTIME 1.0
```

PPP troubleshooting logs

```
LOG RXSTATUSB ONCHANGED
LOG GPSEPEMB ONNEW
LOG GLOEPHEMERISB ONNEW
LOG QZSSEPEMERISB ONNEW
LOG BDSEPEMERISB ONNEW
LOG BDSBCNAV1EPHEMERISB ONNEW
LOG BDSBCNAV2EPHEMERISB ONNEW
LOG BDSBCNAV3EPHEMERISB ONNEW
LOG GALFNAVEPEMERISB ONNEW
LOG GALINAVEPEMERISB ONNEW
LOG RANGE ONTIME 0.5
LOG BESTPOSB ONTIME 1.0
LOG RXCONFIGB ONCE
LOG VERSIONB ONCE
LOG TRACKSTATB ONTIME 10.0
LOG LBANDTRACKSTATB ONTIME 1.0
LOG PPPPOSB ONTIME 1.0
LOG PPPSATSB ONTIME 1.0
LOG TERRASTARINFOB ONCHANGED
LOG TERRASTARSTATUSB ONCHANGED
LOG PSRPOSB ONTIME 1.0
LOG ALMANACB ONNEW
LOG GLOALMANACB ONNEW
LOG GALALMANACB ONNEW
LOG BDSALMANACB ONNEW
LOG QZSSALMANACB ONNEW
LOG IONUTCB ONNEW
LOG GLOCLOCKB ONNEW
LOG LBANDBEAMTABLEB ONCHANGED
```

ALIGN troubleshooting logs

LOG RXSTATUSB ONCHANGED
LOG RAWEPHEMB ONNEW
LOG GLORAWEPHEMB ONNEW
LOG GALINAVRAWEPHEMERISB ONNEW
LOG BDSEPEHEMERISB ONNEW
LOG BESTPOSB ONTIME 1
LOG RANGE B ONTIME 0.5
LOG RXCONFIGA ONCE
LOG VERSIONA ONCE
LOG LOGLISTA ONCE
LOG PORTSTATSA ONTIME 10
LOG ALIGNBSLNENUB ONNEW
LOG ALIGNBSLNXYZB ONNEW
LOG ALIGNDOPB ONNEW
LOG HEADING2B ONNEW
LOG MASTERPOSB ONNEW
LOG ROVERPOSB ONNEW (This log can only be output on a receiver where ALIGN is enabled.)
LOG HEADINGSATSA ONNEW (This log can only be output on a receiver where ALIGN is enabled and configured as the ALIGN rover.)
LOG DUALANTENNAHEADINGB ONTIME 1.0
LOG TRACKSTATB_1 ONTIME 1 (dual antenna receivers only)
LOG RANGE B_1 ONTIME 0.5 (dual antenna receivers only)

Chapter 1 CPT7 overview

SPAN GNSS+INS technology from Hexagon | NovAtel brings together two very different but complementary positioning and navigation systems namely Global Navigation Satellite System (GNSS) and an Inertial Navigation System (INS). By combining the best aspects of GNSS and INS into one system, SPAN technology is able to offer a solution that is more accurate and reliable than either GNSS or INS could provide alone. The combined GNSS+INS solution has the advantage of the absolute accuracy available from GNSS and the continuity of INS through traditionally difficult GNSS conditions.

NovAtel's CPT7 is a scalable, high precision GNSS+INS receiver in a lightweight, compact, environmentally protective enclosure. There are two hardware versions of the CPT7 to meet a range of GNSS applications.

- **CPT7**

The CPT7 combines a dual antenna OEM7720 receiver and a high performance Honeywell HG4930 IMU in a single enclosure to provide an easy to deploy SPAN GNSS+INS and ALIGN system.

- **CPT7700**

The CPT7700 combines an OEM7700 GNSS receiver and a high performance Honeywell HG4930 IMU in a single enclosure to provide an easy to deploy SPAN GNSS+INS system. In addition to the GNSS signals tracked by the CPT7, the CPT7700 also tracks Galileo E6, BeiDou B3I and QZSS L6.



In this document, the term CPT7 is used to represent both the CPT7 and CPT7700. When a section applies to a specific version, the applicable version is identified (e.g. *CPT7 only* or *CPT7700 only*).

The CPT7 and CPT7700 provides the following features:

- Multi-frequency/Multi-constellation
- Dual antenna inputs for single enclosure ALIGN heading solution (*CPT7 only*)
- SPAN GNSS+INS functionality
- Two serial communication ports, 1 RS-422 and 1 RS-232
- One USB communication port
- One Ethernet communication port
- One CAN bus port
- 3 Event outputs (Legacy CPT7 receivers (PN 80023560) provide 2 Event outputs)
- 3 Event inputs (Legacy CPT7 receivers (PN 80023560) provide 2 Event inputs)
- Wheel Sensor (DMI) input (not available on Legacy CPT7 receivers (PN 80023560))
- 16 GB of internal data logging storage (not available on Legacy CPT7 receivers (PN 80023560))
- 4 status LEDs (not available on Legacy CPT7 receivers (PN 80023560))
- PPP, RTK, SBAS and DGPS positioning solutions
- GLIDE and ALIGN positioning options
- Enhanced interference mitigation



In this document, Legacy CPT7 receiver refers to the previous version of the CPT7. Refer to *Differences between CPT7 and Legacy CPT7* on page 206 for a comparison between the current and Legacy CPT7.

Figure 1: CPT7 receiver



Figure 2: CPT7700 receiver







CPT7 technical specifications are provided in *CPT7 technical specifications* on page 182.

1.1 CPT7 connectors

The CPT7 has several connectors for connecting the receiver to other components in the GNSS system.

Table 1: CPT7 connectors

Connector	Label	Description
	RF1	SMA connector for the primary GNSS antenna
	RF2	SMA connector for the secondary GNSS antenna (<i>CPT7 only</i>)
	IO1	16-pin circular connector <ul style="list-style-type: none"> • Power • COM2 (RS-422) • EVENT_IN 1 • EVENT_OUT 1 • EVENT_IN 3 • EVENT_OUT 3 (PPS)
	IO2	16-pin circular connector <ul style="list-style-type: none"> • Power • COM1 (RS-232) • USB • Ethernet • CAN bus • Wheel Sensor (DMI) input • EVENT_IN 2 • EVENT_OUT 2

1.2 CPT7 LEDs

The CPT7 has four LEDs to indicate receiver status.

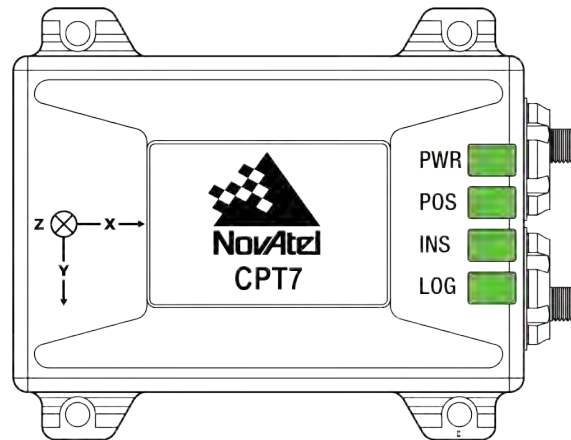

The status LEDs are not available on Legacy CPT7 receivers (PN 80023560).

Figure 3: CPT7 status indicators

The following tables provide information about the CPT7 LEDs and their states.

Table 2: CPT7 and CPT7700 status indicators

Label	Description
PWR	Indicates the power status of the receiver
POS	Indicates the position status of the receiver
INS	Indicates the INS status of the receiver
LOG	Indicates the status of logging to the receiver internal memory

Table 3: PWR (Power) LED

State	Description
Green solid	Operational mode
Yellow solid	In the process of booting
Red solid	Error, for example, invalid receiver AUTH code Receiver firmware or Web User Interface update in progress

Table 4: POS (Positioning) LED

State	Description
Green solid	PPP solution User Accuracy Level (UAL) operational (STEADYLINE)
Green slow blink	RTK integer ambiguity
Green fast blink	Single point or SBAS solution PPP converging or RTK converging Velocity warning or UAL warning
Yellow solid	No solution
Yellow slow blink	UAL Out of Bounds

Table 5: INS LED

State	Description
Off	INS inactive
Green solid	INS solution good
Green slow blink	INS alignment complete
Green fast blink	INS solution free
Green/Yellow alternating blink	INS high variance
Yellow slow blink	INS aligning/determining orientation
Red solid	Error



Refer to *Table 12: Inertial solution status* on page 100 for more information about the INS solution states.

Table 6: LOG (onboard storage) LED

State	Description
Off	The CPT7 is connected to a computer as a mounted device See <i>Access CPT7 internal memory with a computer</i> on page 77
Green solid	Internal logging stopped (memory available)
Green slow blink	Logging to internal memory (memory available)
Green/Yellow alternating blink	Logging to internal memory (low memory)
Yellow solid	Internal logging stopped (low memory)
Yellow fast blink	Memory is mounting or unmounting/busy
Red solid	Internal memory full or corrupt/bad Refer to <i>Repair errors on the CPT7 internal memory</i> on page 78

1.3 Fundamentals of GNSS+INS

GNSS positioning observes range measurements from orbiting GNSS satellites. From these observations, the receiver can compute position and velocity with high accuracy. NovAtel GNSS positioning systems are highly accurate positioning tools. However, GNSS in general has some restrictions which limit its usefulness in some situations. GNSS positioning requires line of sight view to at least four satellites simultaneously. If these criteria are met, differential GNSS positioning can be accurate to within a few centimetres. If however, some or all of the satellite signals are blocked, the accuracy of the position reported by GNSS degrades substantially, or may not be available at all.

In general, an INS uses forces and rotations measured by an IMU to calculate position, velocity and attitude. This capability is embedded in the firmware of OEM7 receivers. Forces are measured by accelerometers in three perpendicular axes within the IMU and the gyros measure angular rotation rates around those axes. Over short periods of time, inertial navigation gives very accurate acceleration, velocity and attitude output. The INS must have prior knowledge of its initial position, initial velocity, initial attitude, Earth rotation rate and

gravity field. Since the IMU measures changes in orientation and acceleration, the INS determines changes in position and attitude, but initial values for these parameters must be provided from an external source. Once these parameters are known, an INS is capable of providing an autonomous solution with no external inputs. However, because of errors in the IMU measurements that accumulate over time, an inertial-only solution degrades with time unless external updates such as position, velocity or attitude are supplied.

The SPAN system's combined GNSS+INS solution integrates the raw inertial measurements with all available GNSS information to provide the optimum solution possible in any situation. By using the high accuracy GNSS solution, the IMU errors can be modelled and mitigated. Conversely, the continuity and relative accuracy of the INS solution enables faster GNSS signal reacquisition and RTK solution convergence.

The advantages of using SPAN technology are its ability to:

- Provide a full attitude solution (roll, pitch and azimuth)
- Provide continuous solution output (in situations when a GNSS-only solution is impossible)
- Provide faster signal reacquisition and RTK solution resolution (over stand-alone GNSS because of the tightly integrated GNSS and INS filters)
- Output high-rate (up to the IMU data rate depending on your logging selections) position, velocity and attitude solutions for high-dynamic applications, see also *Logging restriction important notice* on page 107
- Use raw phase observation data (to constrain INS solution drift even when too few satellites are available for a full GNSS solution)



For more information about GNSS and INS, refer to *An Introduction to GNSS* available on our website at novatel.com/an-introduction-to-gnss

Chapter 2 CPT7 installation

This chapter provides instructions to install the CPT7 and create a GNSS+INS system.

2.1 Shipping box

The following is provided with the CPT7:

- CPT7 I/O1 Cable
- CPT7 I/O2 Cable
- CPT7 and CPT7700 Quick Start Guide (GM-14915172)



The CPT7 I/O cables are not included with CPT7 NC models.

2.2 Additional equipment required

The following additional equipment is required for a typical CPT7 system:

- A 9-36 VDC, fuse (2 A) protected power supply capable of at least 18 W
- A high quality GNSS antenna, such as NovAtel's VEXXIS GNSS-500 or GNSS-800 series antennas
Two GNSS antennas are needed to use the integrated ALIGN heading feature (*CPT7 only*)
- An antenna cable with an SMA male connector at the CPT7 end
Two antenna cables are needed to use the integrated ALIGN heading feature (*CPT7 only*)
- Four #6 size screws for mounting
- A computer with a serial COM, USB or Ethernet port

The following equipment may also be needed, depending on the system configuration:

- Shielded Ethernet cable



Use a serial COM or USB connection to communicate with the receiver first. This provides the ability to configure the computer and CPT7 before using Ethernet.

2.3 Optional accessories

The following optional accessory is available from NovAtel:

- CPT7 Adapter Plate (01020112)
This plate mounts on the CPT7 and provides SPAN-CPT and SPAN-IGM compatible mounting holes.
See *Secure the CPT7 using the adapter plate* on page 35.

2.4 CPT7 cables

To prevent damage to both the receiver and the cables, each connector can be inserted in only one way. Also, the IO1 and IO2 connectors are keyed so that the cable can only be inserted in the connector for which it is intended.

Furthermore, the connectors used to mate the cables to the receiver require careful insertion and removal. The cables for IO1 and IO2 use push/pull connectors. The cables for RF1 and RF2 use threaded connectors. Observe the following when handling cables.

- Make certain to use the appropriate cable for the CPT7 connector
- Insert the connector until it is on straight and secure
- To remove a cable, grasp it by the connector



Do not pull directly on a cable.

Table 7: CPT7 cables

NovAtel part number	Cable name	Purpose
01020208 or 01020697	<i>CPT7 I/O1 cable on page 202</i>	Provides connection to: <ul style="list-style-type: none"> • External power supply (alternate power connection option) • COM2 serial port (RS-422) • Event In 1 • Event Out 1 • EVENT_IN 3 • EVENT_OUT 3 (PPS)
01020209 or 01020690	<i>CPT7 I/O2 cable on page 204</i>	Provides connection to: <ul style="list-style-type: none"> • External power supply • COM1 serial port (RS-232) • USB port • Ethernet port • Wheel Sensor (DMI) input • Event In 2 • Event Out 2

2.5 Selecting a GNSS antenna

NovAtel offers a variety of GNSS antennas, including single, dual and triple-frequency, triple-band and wide-band reference antennas (refer to our web site: novatel.com/products/gps-gnss-antennas for details of available antennas). All antennas include band pass filtering and an LNA. The GNSS antenna chosen depends on the particular application. Each model offers exceptional phase centre stability and a significant measure of immunity against multipath interference. Each antenna has an environmentally sealed radome and all meet the European Union's Restriction of Hazardous Substances (RoHS) and Waste Electrical and Electronic Equipment (WEEE).

If a non-NovAtel GNSS antenna is chosen, a typical antenna LNA gain between 26 dB to 30 dB is recommended in a rover station application.



A dual frequency capable GNSS antenna is required to use SPAN, RTK, ALIGN or dual frequency GLIDE.

An L-band capable antenna is required to receive TerraStar corrections.

For more information about antenna selection, see *Importance of antenna selection* on page 213.

2.6 Choosing a coaxial cable

An appropriate coaxial cable matches the impedances of the antenna and receiver (50 ohms) and has a line loss not exceeding 10.0 dB. If the limit is exceeded, excessive signal degradation may occur and the receiver may not meet performance specifications. NovAtel offers several coaxial cables to meet GNSS antenna interconnection requirements, including:

- 5 m, 15 m and 30 m antenna cable with TNC connectors on both ends (NovAtel part numbers GPS-C006, GPS-C016 and GPS-C032)
- 2.5 m and 5 m antenna cable with an SMA connector on one end and a TNC connector on the other (NovAtel part numbers 60723177 and 60723178)

The CPT7 requires cables with an SMA connector on the CPT7 side or an SMA to TNC adapter.



The SMA to TNC cables (60723177 and 60723178) are not recommended for permanent outdoor use.



For more information about antenna cabling, including using cables longer than 30 m and in-line amplifiers, refer to [APN-077: RF Equipment Selection and Installation](#) available from (novatel.com/support/support-materials/application-notes).



NovAtel recommends using high quality coaxial cables because an impedance mismatch is possible when using lower quality cables and this produces reflections in the cable that increases signal loss. Although other high quality antenna cables can be used, the performance specifications of the OEM7 receivers are warranted only when used with NovAtel supplied accessories.

2.7 Power supply requirements for the CPT7

The CPT7 requires a power supply that provides:

- a voltage in the range of +9 to +36 VDC
- at least 18 W of power (peak)

See *CPT7 electrical and environmental specifications* on page 195 for more power supply specifications.



If the voltage supplied is below the minimum specification, the CPT7 suspends operation. If the voltage supplied is above the maximum specification, the CPT7 may be permanently damaged, voiding the warranty.

The supply must be capable of providing enough current to operate the CPT7, including the initial inrush transient. The supply must also be current limited to 2 A with an external fuse.



The amount of power required depends on the number of constellations and signals tracked, and the features enabled.



Power can be connected to either the IO1 or IO2 port.

Do not connect a power supply to both ports.

2.8 CPT7 installation overview

A CPT7 system consists of a CPT7, a GNSS antenna, power and a communication link (if your application requires real time differential operation). The following diagrams show typical CPT7 installations.

Figure 4: Typical installation of a CPT7 system

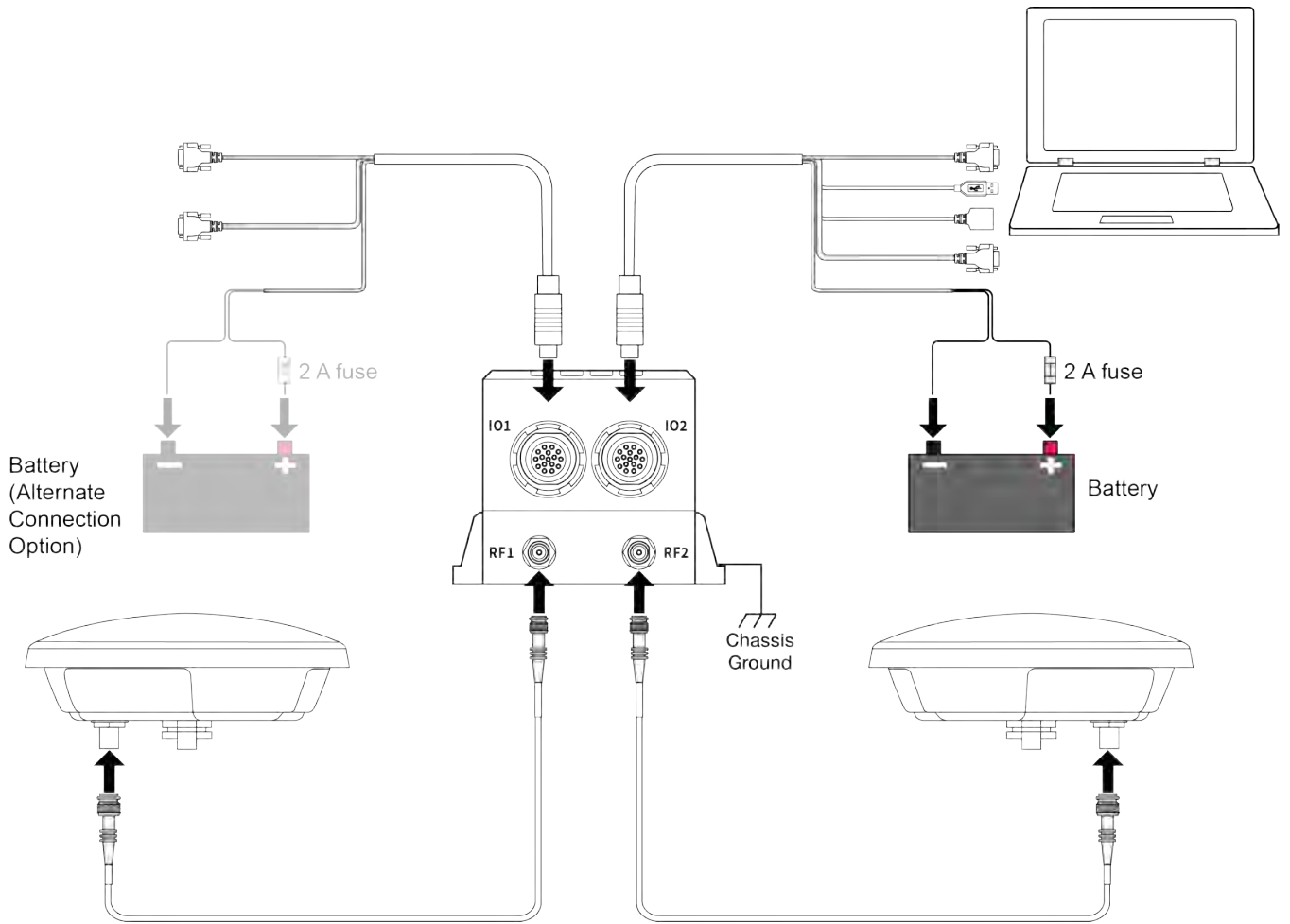
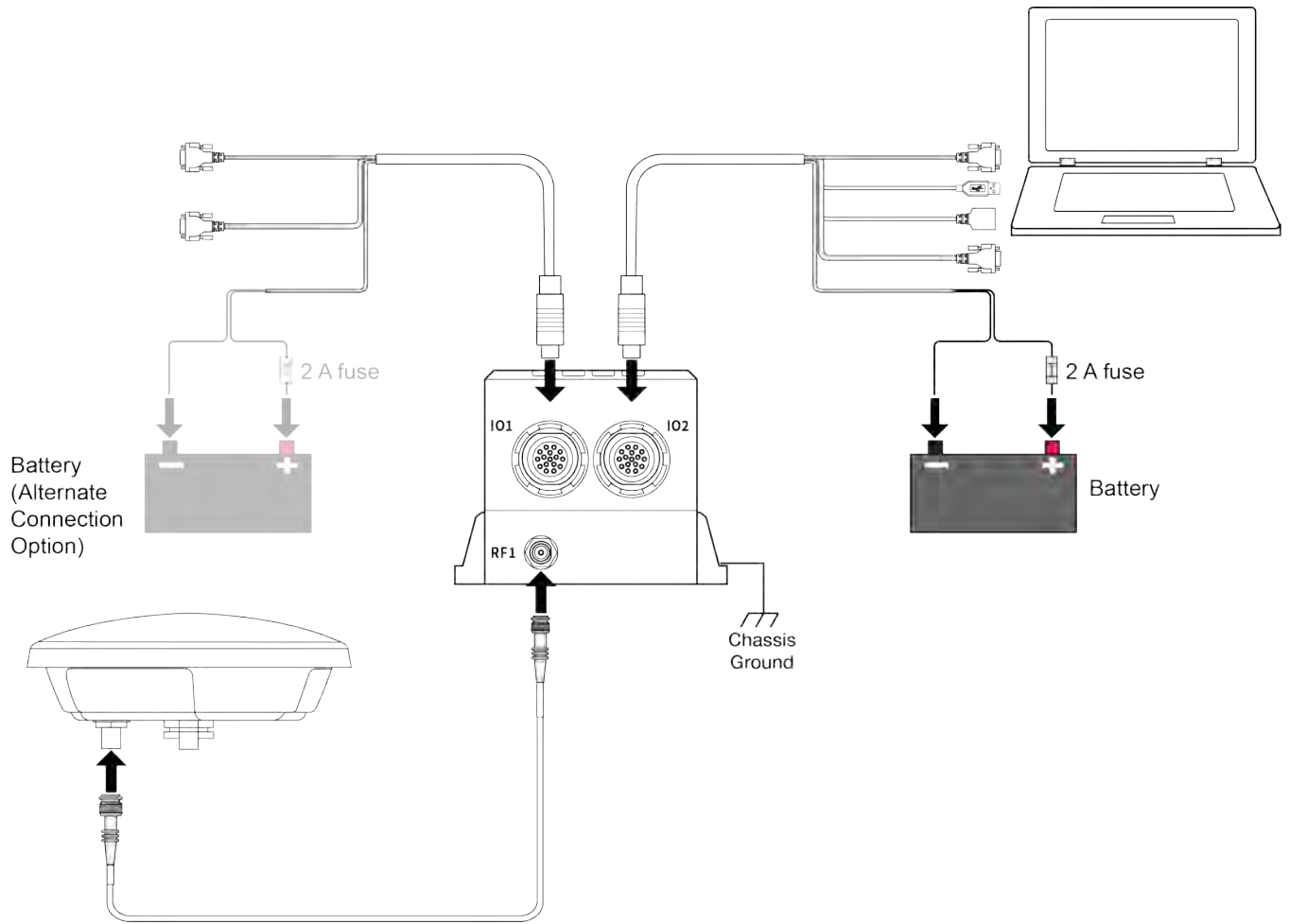

Figure 5: Typical installation of a CPT7700 system



**Power can be connected to either the IO1 or IO2 port.
Do not connect a power supply to both ports.**

Complete the following steps to set up your CPT7 system.

1. Mount the GNSS antenna.

See *Mounting the GNSS antenna* on the next page for details.

2. Mount the CPT7.

See *Mount the CPT7* on page 34 for details.

3. Connect the primary GNSS antenna to the RF1 port.
Connect the secondary GNSS antenna to the RF2 port (*CPT7 only*).

Use an SMA torque wrench to tighten the connection to 0.9 N·m (8 in-lbs) maximum.

The CPT7 supplies +5 VDC (200 mA maximum) to the antenna LNA through the centre conductor of the antenna cable. See *Antenna LNA power* on the next page for more information.

4. Connect the Event input and output signals (optional).

See *Connect I/O signals to the CPT7* on page 40 for details.

5. Connect power to the CPT7.

See *Connect power to the CPT7* on page 40 for details.

6. Connect a data communication device, such as a computer, to the CPT7. A data communication device is used to configure and monitor the receiver.

See *Connect the CPT7 to data communication equipment* on page 38 for details.

Prior to installation of a CPT7 system, please review the following sections:

Importance of lever arms on page 95

Importance of RBV calibration on page 97

Importance of antenna location for ALIGN on page 98

Vibration considerations on page 88

Following these guidelines will help deliver the best performance from the system.

2.9 Mounting the GNSS antenna

The CPT7 is designed to operate with any NovAtel GNSS antenna. See *Selecting a GNSS antenna* on page 28 for more information.

When installing the antenna:

- Choose an antenna location with a clear view of the sky so each satellite above the horizon can be tracked without obstruction. For more information on RF signal propagation and multipath, refer to the NovAtel application note [APN-008: Discussions on RF Signal Propagation and Multipath](http://novatel.com/support/support-materials/application-notes) at novatel.com/support/support-materials/application-notes.
- Mount the antenna on a secure, stable structure capable of safe operation in the specific environment.
- Ensure the antenna cannot move due to dynamics.
- For dual antenna systems only
Heading accuracy is dependent on antenna baseline length. Mount the primary and secondary antennas as far apart as possible. A minimum separation distance of 1 metre is recommended.

For more detailed information about GNSS antenna installation, refer to [APN-077: RF Equipment Selection and Installation](http://novatel.com/support/support-materials/application-notes) at novatel.com/support/support-materials/application-notes.

2.9.1 Antenna LNA power

NovAtel antennas and coaxial cables meet receiver RF input gain requirements. NovAtel coaxial cables are designed to introduce no more than 10 dB loss and NovAtel antennas are equipped with built-in LNAs that provide 29 dB of gain to the satellite signal received.

The power to the antenna LNA is provided through the receiver's RF port centre conductor.

The CPT7 provides +5 VDC $\pm 5\%$ at a maximum of 200 mA.

Antenna supply over current protection limits the LNA power.



If a short circuit or other problem causes an overload of the current supplied to the antenna, the receiver hardware shuts down the power supplied to the antenna. To restore power, power cycle the receiver. The Receiver Status word, available in the **RXSTATUS** log (see [OEM7 Commands and Logs Reference Manual](#)), provides more information about the cause of the problem.

For passive antennas, install a DC block between the receiver and antenna to prevent short circuiting the antenna power.

2.10 Mount the CPT7

Mount the CPT7 in a fixed location where the distance from the CPT7 to the phase center of the GNSS antennas is constant. Ensure that the orientation with respect to the vehicle and antennas is also constant.

The CPT7 enclosure must be grounded.

To ground the CPT7, mount the enclosure to a grounded metal mounting plate or attach a chassis ground cable under one of the mounting screw heads.

Do not install the CPT7 near a heat source, such as vehicle exhaust.

If the CPT7 will be used in an area with a high ambient temperature, above +60°C, and/or additional features have been activated (more channels, HDR mode, etc.), it is strongly recommended to mount the CPT7 to a metal surface such as the NovAtel mount adapter or the metal vehicle chassis. This will improve heat conduction from the unit, optimizing the performance and reducing the risk of a high temperature warning or shutdown.

For the simplest configuration, align the connectors of the CPT7 with the direction of travel of the vehicle and mount the base facing down (see *Figure 6: Default RBV configuration* below) This coincides with X-axis forward and Z-axis down, and the default RBV configuration is valid. Any other mounting requires a rotational offset to be applied. See *Rotational offsets* on page 84 for more information.

Figure 6: Default RBV configuration

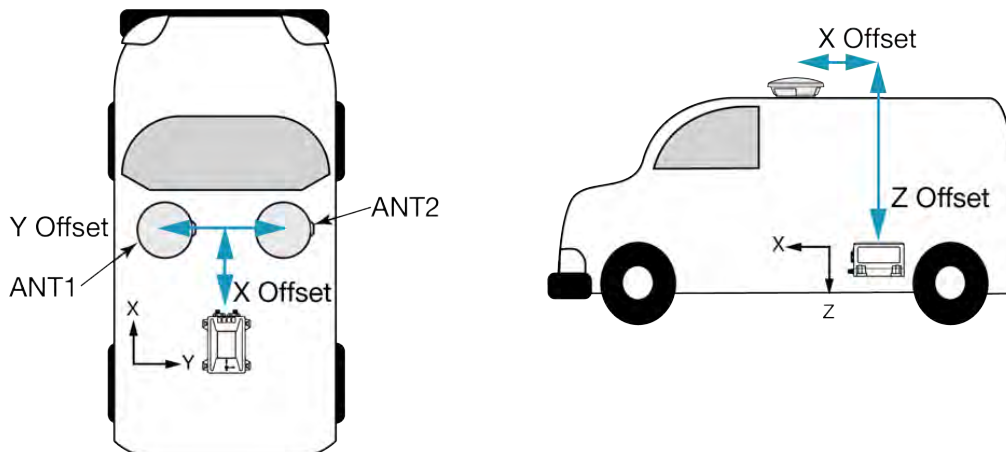

The X, Y and Z axis are marked on the CPT7 enclosure.

The default RBV configuration is `SETINSROTATION RBV 180 0 90 3 3 3`.

Also, it is important to measure the distance from the CPT7 to the primary and secondary GNSS antennas (the Antenna Lever Arms), on the first usage, on the axis defined on the CPT7 enclosure. See also *CPT7 mechanical specifications* on page 190 for dimensional drawings of the CPT7.

Ensure the CPT7 cannot move due to dynamics and that the distance and relative direction between the CPT7 and both antennas is fixed. See *SPAN configuration for CPT7* on page 92.



The closer the primary antenna is to the CPT7, particularly in the horizontal plane, the more accurate the position solution.

Also, your measurements entered using the **SETINSTRANSLATION** command must be as accurate as possible, or at least more accurate than the GNSS positions being used. **For example, a 10 cm error in recording the antenna offset will result in at least a 10 cm error in the output. Millimetre accuracy is preferred.**

The offset from the CPT7 to the antennas, and/or a user point device, must remain constant especially for RTK or DGNS data. Ensure the CPT7, antenna and user point device are bolted in one position perhaps by using a custom bracket.

2.10.1 Securing the CPT7

The CPT7 can be secured directly to the mounting surface or can be secured using the CPT7 Adapter Plate (01020112).

To secure the CPT7 directly to the mounting surface, use four #6 screws that pass through the mounting holes in the CPT7 and into the mounting surface. For the location and spacing of the mounting holes, refer to the mechanical drawings in *CPT7 mechanical specifications* on page 190.



The mounting screws should be torqued to 8 to 10 in-lbs (0.9 to 1.1 N·m).

For information about securing the CPT7 using the adapter plate, refer to *Secure the CPT7 using the adapter plate* below.

2.10.2 Secure the CPT7 using the adapter plate

The CPT7 Adapter Plate (01020112) allows the CPT7 to be installed using the mounting hole spacing designed for the SPAN-CPT or SPAN-IGM-A1/S1.

To secure a CPT7 using the Adapter Plate:

1. Place the CPT7 on the Adapter Plate and align the mounting holes on the CPT7 with the threaded holes in the Adapter Plate.
2. Secure the CPT7 to the Adapter Plate using the four screws (#6 - 32) included with the mounting plate.
3. Secure the Adapter Plate to the mounting location using 4 screws.
See *Figure 7: CPT7 adapter plate* on the next page for the adapter plate dimensions and mounting hole locations.
4. If the CPT7 is replacing a SPAN-CPT or SPAN-IGM-S1, see *Figure 8: Offset from the CPT7 to the SPAN-CPT* on page 37 or *Figure 9: Offset from the CPT7 to the SPAN-IGM-S1* on page 38 for the offset of the centre of navigation of the previous system to the centre of navigation of the CPT7.

Figure 7: CPT7 adapter plate

Dimensions are in mm

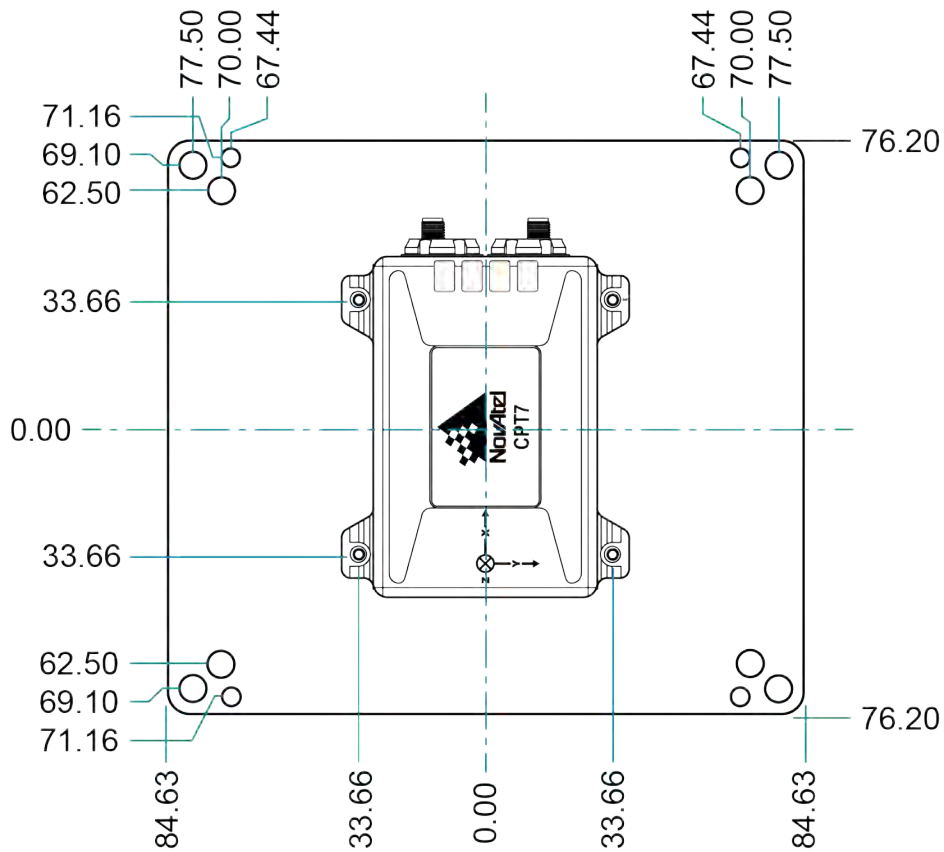
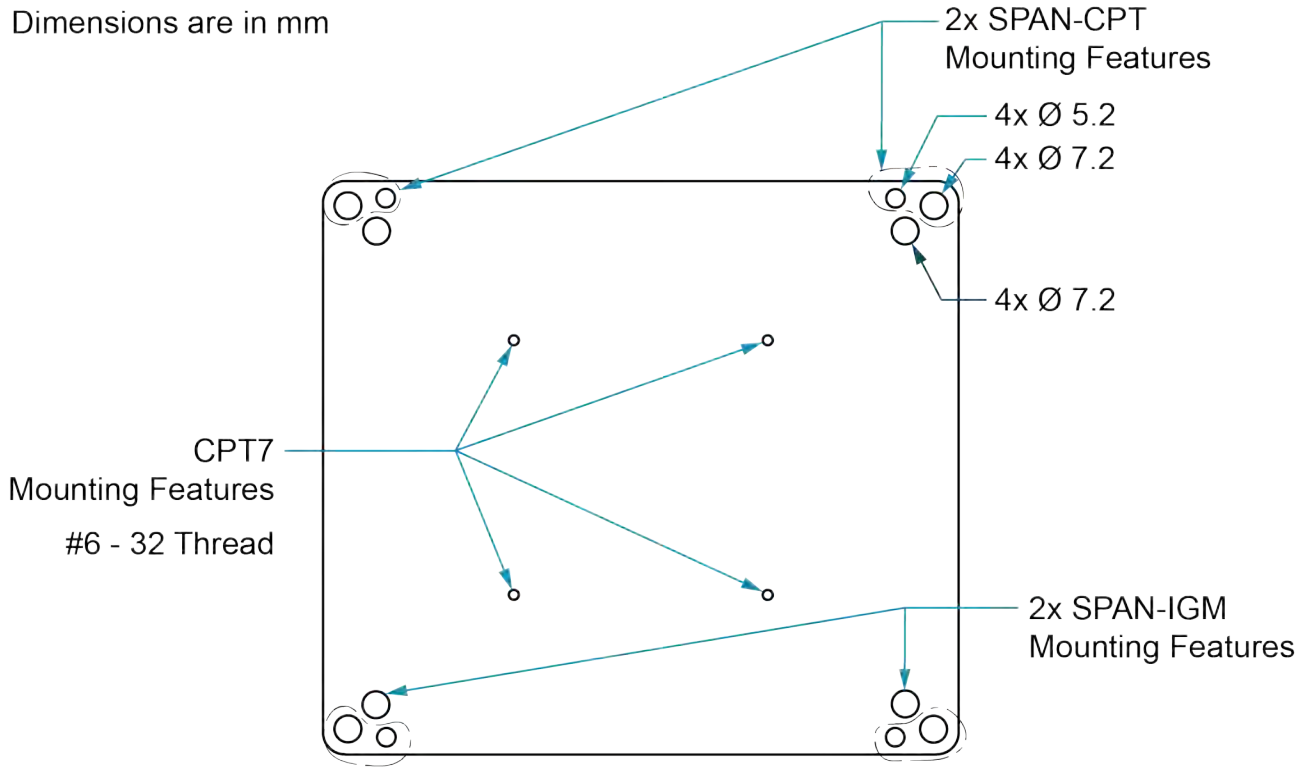
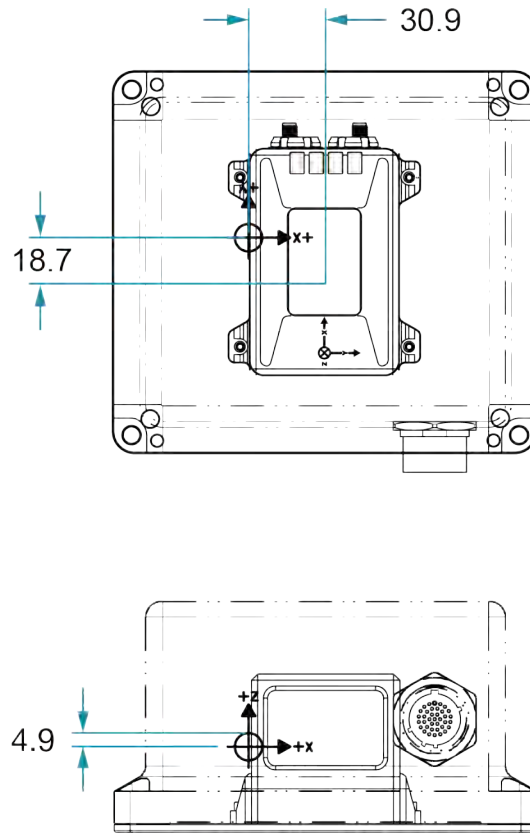

Figure 8: Offset from the CPT7 to the SPAN-CPT



Dimensions are in mm.

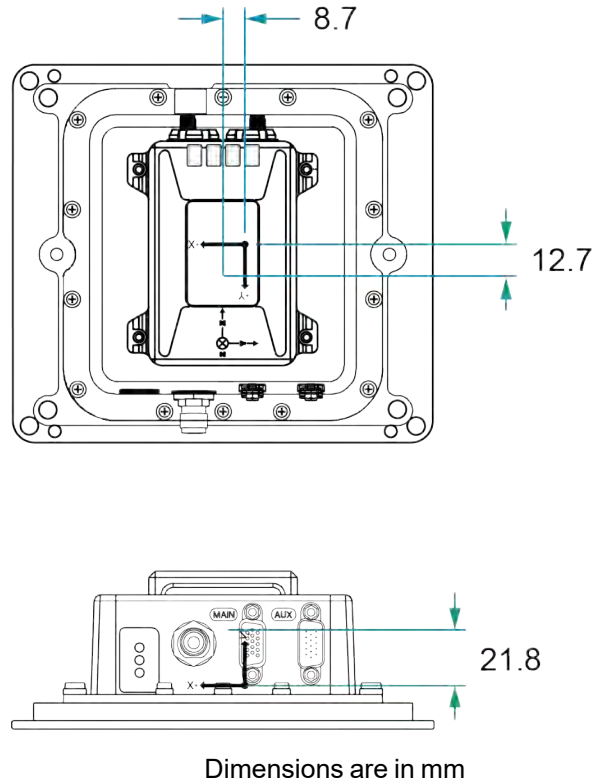

The axis marking on the CPT7 indicates the orientation of the X, Y and Z axis only. It does not indicate the centre of navigation. For the location of the centre of navigation, refer to *Figure 53: CPT7/CPT7700 centre of navigation* on page 194.

Figure 9: Offset from the CPT7 to the SPAN-IGM-S1

2.11 Connect the CPT7 to data communication equipment

The CPT7 can communicate with other devices in the system, such as computers and data loggers, using serial, USB, Ethernet or CAN ports.

- *Serial ports* below
- *USB ports* on the next page
- *Ethernet port* on the next page
- *CAN bus port* on the next page

All data communication connections can be made using the CPT7 I/O1 cable or CPT7 I/O2 cable. For information about these two cables, see *CPT7 I/O1 cable* on page 202 and *CPT7 I/O2 cable* on page 204. These sections also have the connector pin out and connector recommendations for making a custom cable.

2.11.1 Serial ports

The CPT7 has two serial ports: COM1 and COM2. COM1 uses RS-232 protocol and is available on the IO2 port. COM2 uses RS-422 protocol and is available on the IO1 port. Refer to *CPT7 connectors* on page 200 for the pin out of these connectors.

Port settings (bit rate and parity, for example) are software configurable. See *Communications with the receiver* on page 44 for information about configuring the serial ports. Also see *CPT7 data communication specifications* on page 198 for the serial port specifications.

To connect to a serial port using RS-232 protocol:

1. Connect the CPT7 I/O2 cable, or a custom made cable, to the IO2 connector.
2. Connect the DB9 female connector on the cable to the serial port on the computer or other data communication device.

To connect to a serial port using RS-422 protocol:

1. Connect the CPT7 I/O1 cable, or a custom made cable, to the IO1 connector.
2. Connect the DB9 female connector on the cable to the serial port on the computer or other data communication device.

2.11.2 USB ports

The CPT7 has one USB 2.0 compatible port available on the IO2 connector. This USB port operates at 480 Mb/s.

To connect to the USB port:

1. Connect the CPT7 I/O2 cable, or a custom made cable, to the IO2 connector.
2. Connect the USB connector on the CPT7 I/O2 cable to a USB port on the computer or other data communication device.



The NovAtel USB drivers must be installed on your Windows or Linux computer before connecting your computer to the CPT7 using a USB port. For information about the NovAtel USB drivers, see *USB drivers* on page 45.

2.11.3 Ethernet port

The CPT7 has a 10Base-T/100Base-TX Ethernet on the IO2 connector that can be used for communications with external data communications equipment such as computers and data loggers. The Ethernet port supports IPv4 Internet layer, TCP/IP transport, ping and connection from a Telnet client. Users can conduct remote debugging, accept MRTCA (modified RTCA) data and download firmware. OEM7 receivers are also equipped with NTRIP Version 2.0 (Networked Transport of RTCM via Internet Protocol) client and server capability.

To connect to the Ethernet port:

1. Connect the CPT7 I/O2 cable, or a custom made cable, to the IO2 connector.
2. Connect an Ethernet cable from the RJ45 jack on the CPT7 I/O2 cable to an Ethernet port on the computer or other data communication device.

Refer to *Ethernet configuration* on page 133 for instructions on configuring Ethernet and NTRIP.

2.11.4 CAN bus port

The CPT7 has a CAN Bus port available on the IO2 connector.

To connect to the CAN Bus port:

1. Connect the CPT7 I/O2 cable, or a custom made cable, to the IO2 connector.
2. Connect the CAN signals, available on the DB15 connector, to the CAN Bus.



The CPT7 CAN bus port is unterminated. If the CPT7 is at the end of the bus, then the connecting cable must have 120 Ω of resistance integrated into the cable between CANH and CANL in close proximity to the I/O2 connector.

For information about configuring CAN, see *CAN bus* on page 141.

2.12 Connect I/O signals to the CPT7

The CPT7 has several inputs and outputs, also referred to as strobes, that provide status and synchronization signals.

- Event Inputs
- Event Outputs

For more information about the I/O signals, refer to the *CPT7 strobe specifications* on page 199.

To access the EVENT_IN1, EVENT_OUT1, EVENT_IN3 or EVENT_OUT3 signals, connect the CPT7 I/O1 Cable, or a custom made cable, to the IO1 connector. The Event signals are available on the DB15 connector of the CPT7 I/O1 cable.

To access the EVENT_IN2 or EVENT_OUT2 signals, connect the CPT7 I/O2 Cable, or a custom made cable, to the IO2 connector. The Event signals are available on the DB15 connector of the CPT7 I/O2 cable.

For information about the CPT7 I/O cables, see *CPT7 I/O1 cable* on page 202 or *CPT7 I/O2 cable* on page 204. These sections also have the connector pin out and connector recommendations for making a custom cable.

2.13 Connect power to the CPT7



Power can be connected to either the IO1 or IO2 port.

Do not connect a power supply to both ports.

To connect power to the CPT7:

1. Connect the CPT7 I/O1 Cable, CPT7 I/O2 Cable or a custom made interface cable to the CPT7. See *CPT7 I/O1 cable* on page 202 or *CPT7 I/O2 cable* on page 204 for information about these cables.
2. Connect the bare wires of the I/O cable to a 9 to 36 VDC power supply.
For details about the power supply required, see *Power supply requirements for the CPT7* on page 29.



Ensure the VIN line is connected to the positive pole of the power source and the GND line is connected to the negative pole of the power source.



The CPT7 enclosure must be grounded.

To ground the CPT7, mount the enclosure to a grounded metal mounting plate or attach a chassis ground cable under one of the mounting screw heads.

2.13.1 Fuse for the power supply

Install a user supplied 2 A slow blow fuse in the positive line of the connection to the power source to protect the power supply wiring and your warranty.

Figure 10: Fuse for CPT7 power supply

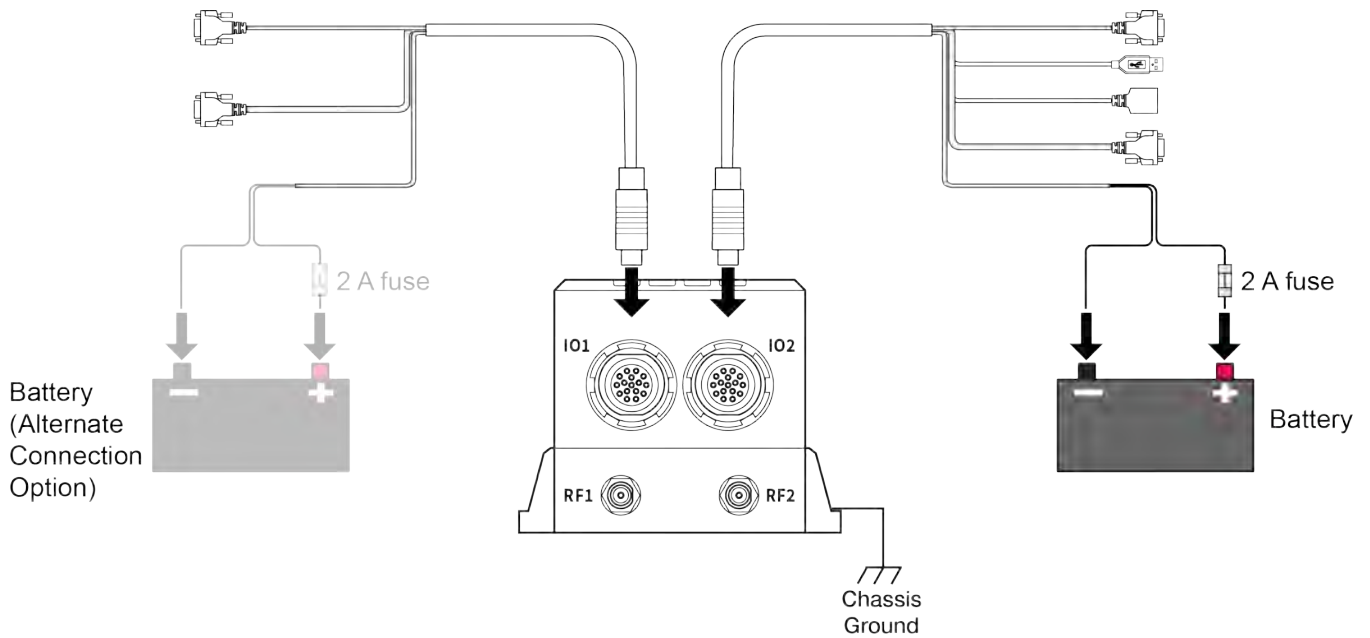

**Power can be connected to either the IO1 or IO2 port.
Do not connect a power supply to both ports.**

Table 8: Fuse/Holder recommendations

Fuse	Holder
BK/MDA-2-R Fuse (or equivalent)	BK/HFA-R Fuse (or equivalent)
BK/MDL-2-R Fuse (or equivalent)	



The fuse and holder are made by Cooper/Bussmann; available from Digikey.

2.13.2 Vehicle installation

If the receiver is installed in a vehicle, it is recommended that a dedicated battery be provided for the receiver that is isolated from the engine starter battery. When a vehicle engine is started, the voltage on the starter battery can dip below the CPT7 minimum voltage or cut-out to ancillary equipment causing the receiver to lose lock and calibration settings.

Figure 11: Dedicated battery for the CPT7

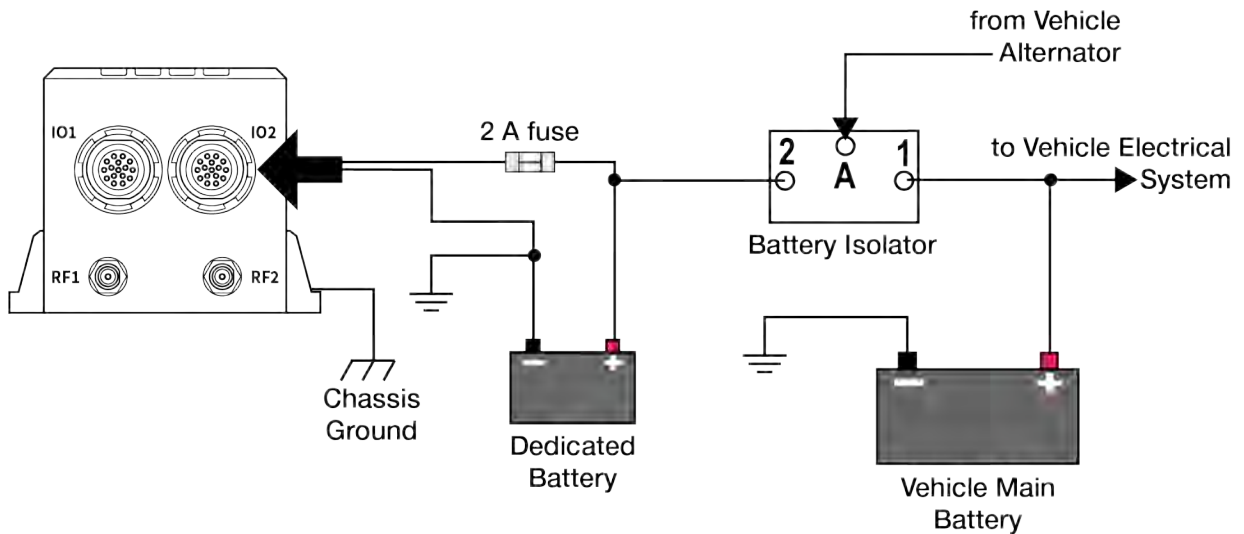

2.14 Check that the CPT7 is operating

After the CPT7 is installed, powered up and connected to a GNSS antenna, use the following procedure to ensure the receiver is operating.

1. Connect the CPT7 to a computer using a serial or USB cable.
2. Open **NovAtel Application Suite**, establish a connection to the CPT7 and open the *Terminal* window. Alternately, open a terminal emulation program and establish a connection to the CPT7.



For information about installing and using NovAtel Application Suite, refer to docs.novatel.com/Tools/Content/ToolsSuite/Overview.htm.

3. Send the following command:

```
LOG VERSION
```

The VERSION log is returned.

```
<VERSION COM1 0 46.0 FINESTEERING 0 5.802 02004020 3681 14755
< 5
< GPSCARD "FDDRYNTBNS1" "DMMU17260099F" "OEM7720-0.00F"
"OM7CR0802AN0002" "OM7BR0002RBG000" "2018/Mar/22" "05:57:24"
< OEM7FPGA "" "" "" "OMV070001RN0000" "" "" ""
< DEFAULT_CONFIG "" "" "" "SC7CR0802AN0002" "" "2018/Mar/22"
"05:57:29"
< PACKAGE "" "" "" "SC7PR0802AN0002" "" "2018/Mar/22" "05:57:48"
< IMUCARD "HG4930_AN04" "" "" "" "" "" ""
```

4. Check that the Time Status is **FINESTEERING** which represents that time is fine set and being steered.
5. Check the Receiver Status word (02004020 in this example). If the lowest bit (bit 0) is set, the receiver has errors.



For information about the other digits in Receiver Status word, refer to the **RXSTATUS** log in the [OEM7 Commands and Logs Reference Manual](#).



It can take about a minute for time status to reach FINESTEERING depending on number of satellites being tracked. This assumes the antenna is located in an open sky environment and the RF set up meets the requirements.

Chapter 3 OEM7 receiver operation

Before operating the receiver for the first time, use the installation instructions in *CPT7 installation* on page 27. The following instructions are based on a configuration similar to the following figure.

Figure 12: Basic CPT7 connection interfaces (example)

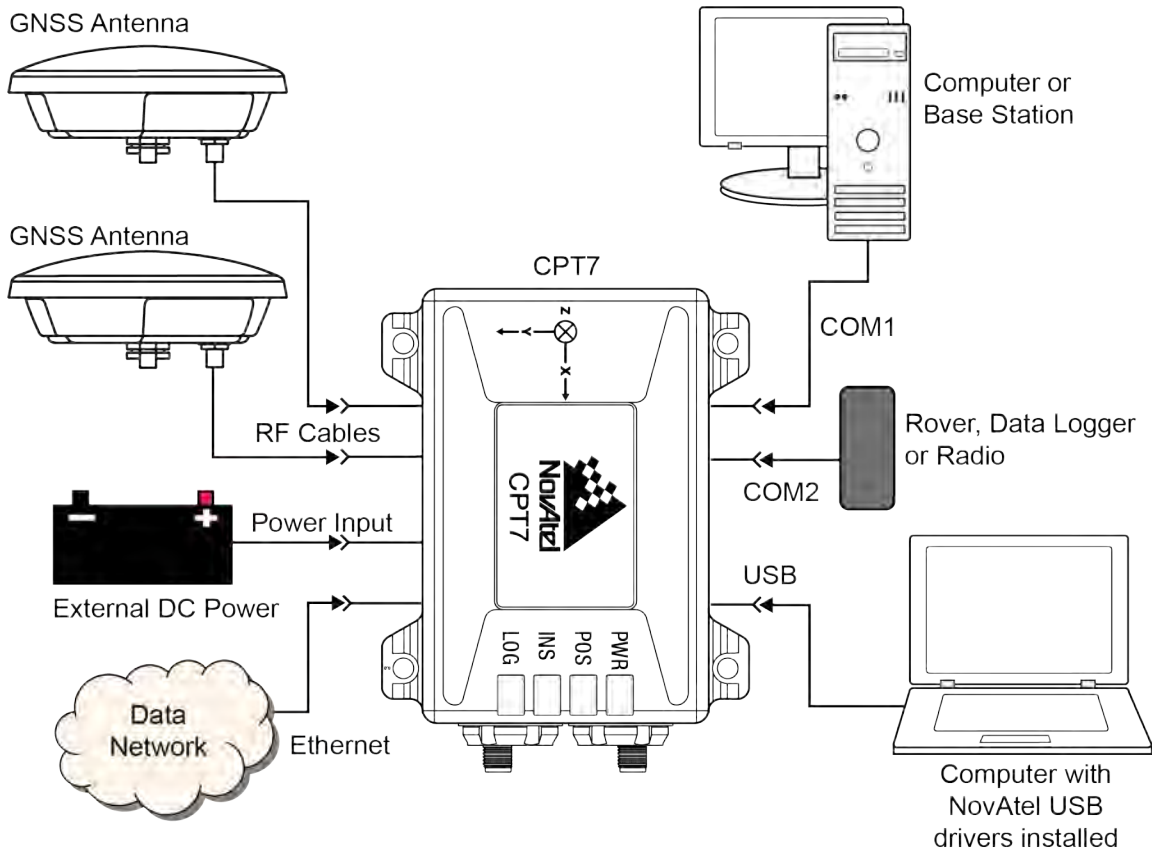

The figure above does not show all necessary hardware. Also see *Figure 13: Basic differential setup* on page 50 for a base/rover example.

3.1 Communications with the receiver

Communication is established with the receiver using a data terminal or computer connected to the receiver by a variety of methods:

- *USB communications* on the next page
- *Serial port communications* on the next page
- *Ethernet communications* on page 47
- *ICOM communications* on page 47
- *CAN bus communications* on page 48

When connected to the receiver, enter commands directly from a terminal or through terminal emulation software on a computer. For example:

- **NovAtel Manage Web** - NovAtel Manage Web is a browser based tool used to monitor, configure and update a variety of receiver functions. For information about using Manage Web, refer to the online documentation (docs.novatel.com/Tools).
- **NovAtel Application Suite** - NovAtel Application Suite is set of computer based applications that simplify the configuration and monitoring of NovAtel receivers. For information about installing and using NovAtel Application Suite, refer to the online documentation (docs.novatel.com/Tools).
- Any console/command line application

To maximize the application of the receiver's capabilities, become familiar with the commands and logs described in the [OEM7 Commands and Logs Reference Manual](#).

3.1.1 USB communications

To communicate between an OEM7 receiver and a computer using a USB port, NovAtel USB drivers must be installed on the computer. These USB drivers are included in Windows 10 and Windows 11. If you are using an earlier version of Windows or are using Linux, the USB drivers are available on the NovAtel website at novatel.com/support/support-materials/software-downloads.

After the NovAtel USB drivers are installed, no additional configuration is required to use the USB ports.

USB drivers

NovAtel USB drivers for OEM7 receivers are available for Windows 7, Window 8, Windows 10, Windows 11 and Linux.

The NovAtel USB drivers provide three virtual serial ports over a single USB 2.0 connection. The three virtual serial ports are available to existing Windows or Linux applications which use COM ports to communicate (for example, NovAtel Application Suite). The NovAtel USB drivers assign COM port numbers sequentially following any existing ports on the computer. For example, if a computer has COM1 and COM2 ports, the NovAtel USB drivers assign COM3 to USB1, COM4 to USB2 and COM5 to USB3.



USB communications are not suitable for use in vehicles.



A computer has several USB ports. The assignment of COM port numbers is tied to a USB port on the computer. This allows receivers to be switched without Microsoft Windows assigning new COM ports. However, if the receiver is connected to a different physical USB port, Windows detects the receiver's presence and assigns three new COM port numbers.

3.1.2 Serial port communications

The receiver can communicate with a computer or terminal via a serial port. For communication to occur, both the receiver and the operator interface have to be configured properly. The receiver's default port settings are:

- 9600 bps
- no parity
- 8 data bits
- 1 stop bit
- no handshaking
- echo off
- break on

The data transfer rate determines how fast information is transmitted. Take for example a log whose message byte count is 96. The default port settings allows 10 bits/byte (8 data bits + 1 stop bit + 1 framing bit). It therefore takes 960 bits per message. To get 10 messages per second then requires 9600 bps. Also remember that even if you set the bps to 9600, the actual data transfer rate may be lower and depends on the number of satellites being tracked, data filters in use, and idle time. It is therefore suggested that you leave yourself a margin when choosing a data rate.



The minimum suggested baud rate for most applications is 115200 bps for GNSS only or 230400 bps for GNSS+INS. If the buffer overrun flag is present in the **RXSTATUS** log (refer to the [OEM7 Commands and Logs Reference Manual](#)), log at a higher baud rate if possible, or change to a medium supporting higher bandwidth (USB or Ethernet).

Although the receiver can operate at data transfer rates as low as 300 bps, this is not recommended. For example, if several data logs are active (that is, a significant amount of information needs to be transmitted every second) but the bit rate is set too low, data overflows the serial port buffers, causing an error condition in the receiver status that results in lost data.

The following ports are supported and can be configured using the commands listed. Refer to the commands listed in the [OEM7 Commands and Logs Reference Manual](#) for detailed instructions.

Table 9: Serial ports supported

Receiver type	Port supported	Configuration command
CPT7	COM1, COM2	SERIALCONFIG

Change the COM port settings

To change the settings on a COM port, use the **SERIALCONFIG** command. For example:

- To change the data rate of COM2 to 115200, enter:

```
SERIALCONFIG COM2 115200
```

- To change the data rate of COM1 to 57600 and enable even parity, enter:

```
SERIALCONFIG COM1 57600 E
```

Communicating using a remote terminal

One method of communicating with the receiver is through a remote terminal. To communicate with the terminal, the receiver requires only the RX, TX and GND lines be used. Ensure the terminal's communications set up matches the receiver's port settings.

Communicating using a computer

A computer can emulate a remote terminal as well as provide the added flexibility of supporting multiple command batch files and data logging storage files. Use any standard communications software package that emulates a terminal to establish bidirectional communications with the receiver. Examples include NovAtel Application Suite and PuTTY. All data is sent as raw 8-bit binary or ASCII characters.

Refer to *Communicating with the receiver* on page 48 for details.

3.1.3 Ethernet communications

The CPT7 is equipped with a 10-Base-T/100-Base-TX Ethernet port that supports IPv4 Internet layer, TCP/IP transport and telnet. Users can conduct remote debugging, accept MRTCA (modified RTCA) data and update firmware. OEM7 receivers are also equipped with NTRIP Version 2.0 (Networked Transport of RTCM via Internet Protocol) client and server capability.

The Ethernet port must be configured before using. Refer to *Ethernet configuration* on page 133 for configuration details.



The Ethernet ports are Safety Extra-Low Voltage (SELV) circuits only and are suitable for connection within a building only. Do not connect them to Telephone Network Voltage (TNV) circuits.

If intra-building connections are required, or the OEM7 receiver is installed in an outdoor enclosure, a suitably rated Ethernet router or switch should be installed between the receiver Ethernet port and the network connection.



Issue the **SAVEETHERNETDATA ETHA** command to ensure port settings are retained after a reset and automatically used at boot time. The **SAVEETHERNETDATA ETHA** command is not applicable to the **ICOMCONFIG** and **NTRIPCONFIG** command settings. The **SAVEETHERNETDATA ETHA** command takes precedence over the **SAVECONFIG** command configuration.



OEM7(s) are intended to be integrated into a larger system or used within a laboratory environment. The system integrator is responsible for providing secure network and physical access to the OEM7 card(s).

3.1.4 ICOM communications

ICOM ports are virtual ports used for Ethernet connections. The transport/application layer of the ICOM ports can be configured to use Transmission Control Protocol (TCP) for internet IP or User Datagram Protocol (UDP) a slower and less reliable IP protocol.

Refer to **DNSCONFIG** command for Ethernet DNS configuration. If using DHCP, DNS is automatically set.

The following are the default ICOM configurations:

- ICOMCONFIG ICOM1 TCP :3001
- ICOMCONFIG ICOM2 TCP :3002
- ICOMCONFIG ICOM3 TCP :3003
- ICOMCONFIG ICOM4 TCP :3004
- ICOMCONFIG ICOM5 TCP :3005
- ICOMCONFIG ICOM6 TCP :3006
- ICOMCONFIG ICOM7 TCP :3007

Each ICOM port can act as a server (waiting for an external connection to be made) or as a client (actively establishing a connection to a specific port).

For details on the ICOM port commands, refer to **IPCONFIG** command, **ICOMCONFIG** command and **ETHCONFIG** command in the [OEM7 Commands and Logs Reference Manual](#).

3.1.5 CAN bus communications

The CPT7 and CPT7700 have one CAN port. This CAN port supports data rates up to 1 Mbps.

The CPT7 and CPT7700 support J1939 and NMEA2000 CAN protocols. For information about configuring the CAN ports to use J1939 or NMEA200 protocols, refer to *CAN bus* on page 141.

The CPT7 and CPT7700 can also write messages to and read messages from the CAN bus using OEM7 commands and logs. This is typically implemented using the NovAtel API. For more information refer to Using Lua to Access I/O Devices Connected to the Receiver in the *OEM7 NovAtel API User Manual*.



The CPT7 and CPT7700 have internal CAN transceivers, however they still require proper bus terminations.

3.2 Getting started

The receiver's software resides in flash memory. When first powered, it undergoes a complete self-test. If an error condition is detected during the self-test, the status word changes. This self-test status word can be viewed in the header of any data output log. Refer to Messages in the [OEM7 Commands and Logs Reference Manual](#) for header information. If a persistent error occurs, contact your local NovAtel dealer. If the dealer cannot resolve the problem, contact NovAtel Customer Support directly using one of the methods listed in *Customer Support* on page 16.

3.2.1 Communicating with the receiver

You can communicate with the receiver using NovAtel Manage Web, NovAtel Application Suite or a terminal emulation program.



For instructions on using NovAtel Manage Web and NovAtel Application Suite, refer to docs.novatel.com/Tools.

When the receiver is first turned on, no data is transmitted from the COM ports except for the port prompt.

Any of the COM port prompts indicate that the receiver is ready and waiting for command input. The screen may display other port names for other port types.



1. Output from receiver self-tests may take some time. On startup, the receiver is set to log the `RXSTATUSEVENTA` log `ONNEW` on all ports. See *RXSTATUSEVENT log* on page 148 for more details.
2. If NovAtel Application Suite is unable to locate the receiver, use a different COM port to communicate with the receiver. When communication has been established, issue a **FRESET STANDARD** command. The original communications port should be ready for use. See the **FRESET** command for more information.

An example of a response to an input **LOG** command:

```
[COM2] LOG COM1 BESTPOS ONTIME 1
<OK
```

In this example, [COM2] is the port prompt.

If the command was accepted, the receiver responds with:

<OK

If a command is entered incorrectly, the receiver responds with:

<ERROR:Invalid Message ID (or a more detailed message)



Ensure the computer does not sleep or hibernate during a logging session or data will be lost.

3.3 Transmitting and receiving corrections

Corrections can be transmitted from a base station to a rover station to improve position accuracy. The base station is the GNSS receiver that acts as the stationary reference. The stationary reference has a known position and transmits correction messages to the rover station. The rover station is the GNSS receiver that does not know its exact position and requires correction messages from a base station to calculate differential GNSS positions. An example of a differential setup is shown in *Figure 13: Basic differential setup* on the next page.

Figure 13: Basic differential setup

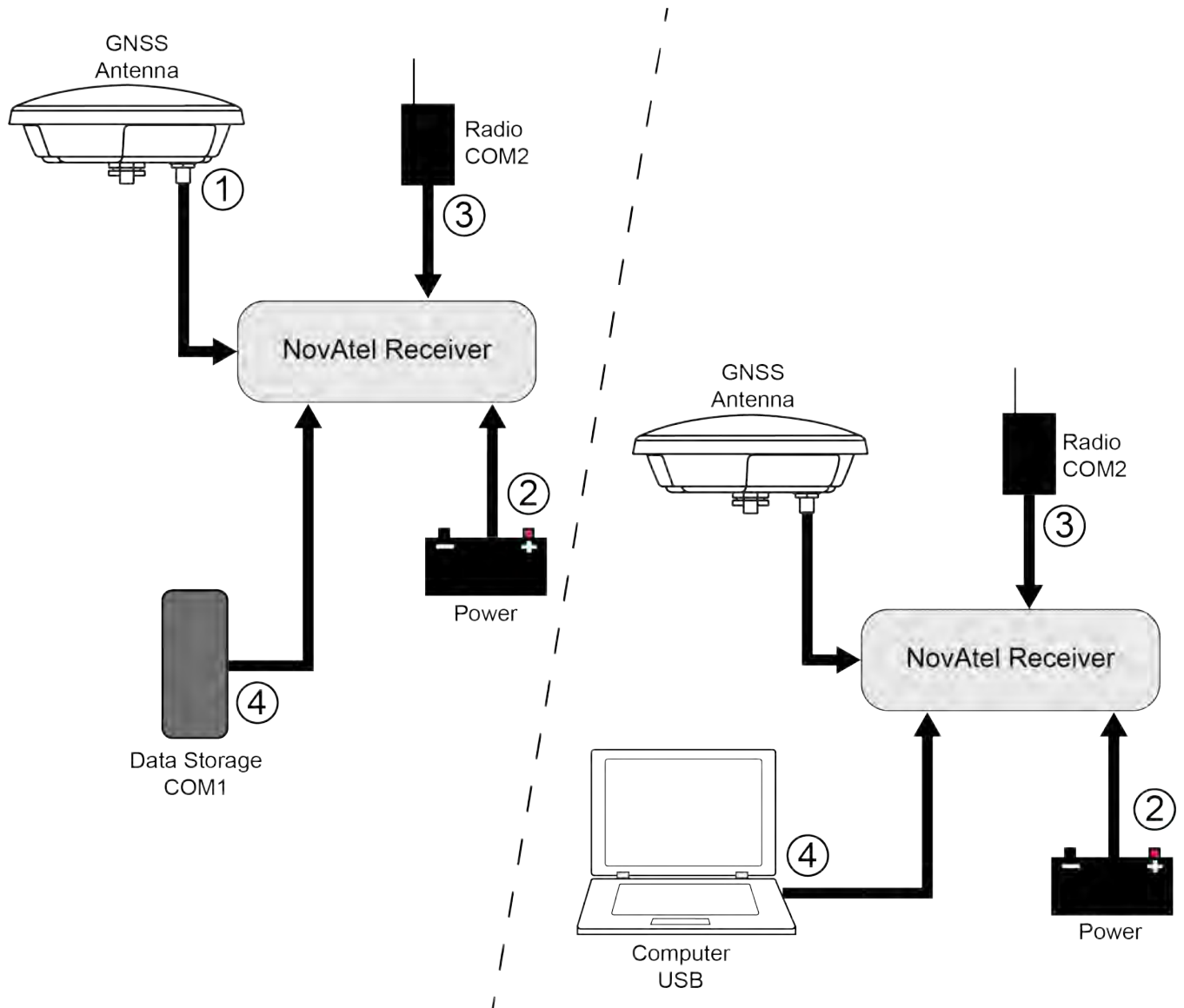

Rover Setup

- 1 Mount and connect a GNSS antenna
- 2 Connect a fused power supply (user supplied)
- 3 Connect a radio device to COM2 (user supplied)
- 4 Connect a storage device to COM1 (user supplied)

Base Setup

- 1 Mount and connect a GNSS antenna
- 2 Connect a fused power supply (user supplied)
- 3 Connect a radio device to COM2 (user supplied)
- 4 Connect a computer to COM1 for setup and monitoring (user supplied)

To receive corrections, a data link between the base station and the rover station is required. The base and rover stations can both be NovAtel receivers, however NovAtel receivers will work with some other brands. Contact Customer Support for further details (refer to *Customer Support* on page 16 for details).

The data link should support a rate of at least 19200 bits per second, but a rate of 115200 bits per second, with less than 4.0 s latency, is recommended.



Unlike the base/rover concept, SBAS and PPP corrections can be applied directly to a single receiver.

When the base and rover are set up, configure them as shown in the configuration examples in *Base station configuration* below and *Rover station configuration* on the next page.

3.3.1 Defining antenna and base antenna

The type of antenna for the receiver and/or the base receiver can be defined using the **THISANTENNATYPE** command and **BASEANTENNATYPE** command respectively.

The Phase Centre Variation (PCV) and the Phase Centre Offset (PCO) for each can also be specified using the **THISANTENNAPCV** command and **THISANTENNAPCO** command or the **BASEANTENNAPCV** command and **BASEANTENNAPCO** command.

Refer to the [OEM7 Commands and Logs Reference Manual](#) for command details.

3.3.2 Base station configuration

At the base station, enter the following commands:

```
serialconfig [port] baud [parity[databits[stopbits[handshaking[break]]]]]
interfacemode port rx_type tx_type [responses]
fix position latitude longitude height (enter your own lat, long and hgt values)
log port message [trigger [period]] (port = COM2 / refer to Figure 13: Basic differential setup on the previous page)
saveconfig (optional)
```

The following sections are examples of base station configurations.

RTK Automated Correction Generation

```
fix position lat lon hgt (enter your own lat, lon, hgt)
generatertkcorrections rtcmv3 com2
```

RTCM V3

```
serialconfig com2 19200 N 8 1 N on
interfacemode com2 none rtcmv3 off
fix position lat lon hgt (enter your own lat, lon, hgt)
log com2 rtcml004 ontime 1
log com2 rtcml006 ontime 10
log com2 rtcml019 ontime 120
saveconfig (optional)
```

RTCM V3 with GLONASS

```

serialconfig com2 19200 N 8 1 N on
interfacemode com2 none rtcmv3 off
fix position lat lon hgt (enter your own lat, lon, hgt)
log com2 rtcm1004 ontime 1
log com2 rtcm1012 ontime 1
log com2 rtcm1006 ontime 10
log com2 rtcm1033 ontime 10
log com2 rtcm1019 ontime 120
log com2 rtcm1020 ontime 120
saveconfig (optional)

```

NOVATELX

```

serialconfig com2 19200 N 8 1 N on
interfacemode com2 none novatelx off
fix position lat lon hgt (enter your own lat, lon, hgt)
log com2 novatelxobs ontime 1
saveconfig (optional)

```



For more information, refer to the **FIX** command, **INTERFACEMODE** command, **SAVECONFIG** command and **SERIALCONFIG** command in the [OEM7 Commands and Logs Reference Manual](#).

3.3.3 Rover station configuration

At the rover station, enter the following commands:

```

serialconfig [port] baud [parity[ databits [stopbits [handshaking [break]]]]]
interfacemode port rx_type tx_type [responses]
saveconfig (optional)

```

The following sections are examples of rover configurations, if COM2 was connected to the correction source.

RTK automated correction detection

```

serialconfig com2 19200 N 8 1 N on
interfacemode com2 auto none off
saveconfig (optional)

```

RTCM V3

```

serialconfig com2 19200 N 8 1 N on
interfacemode com2 rtcmv3 none off
saveconfig (optional)

```

RTCM V3 with GLONASS

```
serialconfig com2 19200 N 8 1 N on
interfacemode com2 rtcmv3 none off
saveconfig (optional)
```

NOVATELX

```
serialconfig com2 19200 N 8 1 N on
interfacemode com2 NOVATELX none off
saveconfig (optional)
```



For more information, refer to the **INTERFACEMODE** command, **SAVECONFIG** command and **SERIALCONFIG** command in the [OEM7 Commands and Logs Reference Manual](#).

3.3.4 Configuration notes

For compatibility with other GNSS receivers and to minimize message size, use the standard form of RTCMV3 corrections shown in the base and rover examples in *Transmitting and receiving corrections* on page 49. This requires using the **INTERFACEMODE** command to dedicate one direction of a serial port to one message type only. When the **INTERFACEMODE** command is used to change the mode from the NOVATEL default, the NovAtel format messages can no longer be used.

To mix NovAtel format messages and RTCM V3 messages on the same port, leave the interface mode set to NOVATEL and log out variants of the standard correction messages with a NovAtel header. ASCII or binary variants can be requested by appending an A or B to the standard message name. For example, on the base station:

```
interfacemode com2 novatel novatel
fix position 51.11358042 -114.04358013 1059.4105
log com2 rtcml004b ontime 2
```



1. Interface mode must be set to NOVATEL for the receiver to issue logs with an A or B suffix.
2. Using the receiver in NOVATEL mode consumes more CPU bandwidth than using the native differential messages as shown in *Base station configuration* on page 51.
3. To find information on how to send multiple commands and log requests from a computer, search our knowledge database available at novatel.com/support.

At the rover, leave the interface mode default settings (interfacemode com2 novatel novatel). The rover recognizes the default and uses the corrections it receives with a NovAtel header.

The **PSRDIFFSOURCE** command and **RTKSOURCE** command set the station ID values that identify the base stations from which to accept pseudorange or RTK corrections. They are useful commands when the rover station is receiving corrections from multiple base stations.

3.4 GLIDE

NovAtel's GLIDE is a positioning algorithm for single-frequency GPS and GPS/GLONASS applications. GLIDE produces a smooth position output tuned for applications where time relative accuracy (pass-to-pass) is more important than absolute accuracy. Because of this, it is well suited for agricultural applications.

Multipath signals tend to induce time varying biases and increase the measurement noise on the L1/L2 pseudorange measurements. Carrier phase measurements are much less susceptible to the effects of multipath. The GLIDE algorithm fuses the information from the L1 code and the L1 phase measurements into a Position Velocity Time (PVT) solution.

GLIDE includes settings for a dynamic mode, a static mode and an “auto” mode, where the filtering parameters are automatically adjusted as vehicle velocity varies between stationary and dynamic states.

3.4.1 Dual-frequency GLIDE

NovAtel’s dual-frequency GLIDE technology adds to the superior pass-to-pass performance provided by single-frequency GLIDE. Dual-frequency GLIDE is ideal for agricultural and machine guidance applications where relative positioning is critical. Using GLIDE significantly reduces the variation in position errors to less than 1 cm from one epoch to the next. Dual-frequency GLIDE improves the absolute accuracy of the GLIDE position and creates a robust solution resistant to the effects of high ionospheric activity. GLIDE works in all code positioning modes, including single point, DGNSS and SBAS.

Refer to the NovAtel white paper on [GLIDE Technology](#) for more information on GLIDE and [APN-038: Pseudorange/Delta-Phase \(PDP\) and GLIDE Filters](#) along with other information available from novatel.com/support/support-materials/application-notes.

3.4.2 PDP and GLIDE configurations

GLIDE is a mode of the Pseudorange/Delta-Phase (PDP) position filters. PDP and GLIDE can be used for single-frequency single point, WAAS or DGNSS positioning. Refer to the **PDPFILTER** command and **PDPMODE** command in the [OEM7 Commands and Logs Reference Manual](#).

To reset the PDP or GLIDE filter:

```
pdpfilter reset
```

To enable the PDP filter:

```
pdpfilter enable
```

Ensure the **PDPFILTER** command is used before the **PDPMODE** command. Set the PDP type and kinematic type according to the application. For most kinematic applications:

```
pdpmode glide dynamic or pdpmode glide auto
```

The rest of the setup is position type and log dependent according to the application. See **PSRDIFFSOURCE** command, **INTERFACEMODE** command and **SERIALCONFIG** command in the [OEM7 Commands and Logs Reference Manual](#) for details. Also refer to the NovAtel application note [APN-038: Pseudorange/Delta-Phase \(PDP\) and GLIDE Filters](#) available from our web site at novatel.com/support/support-materials/application-notes.

3.5 STEADYLINE

The STEADYLINE functionality helps mitigate the discontinuities that often occur when the receiver changes GNSS positioning modes. The effect is especially evident when a receiver transitions from an RTK position mode solution to a lower accuracy “fall back” solution, such as DGPS, WAAS+GLIDE or even autonomous GLIDE (see *Figure 14: Positioning Change Without STEADYLINE* on the next page). Smooth transitions are particularly important for agricultural steering applications where sudden jumps are problematic.

Figure 14: Positioning Change Without STEADYLINE

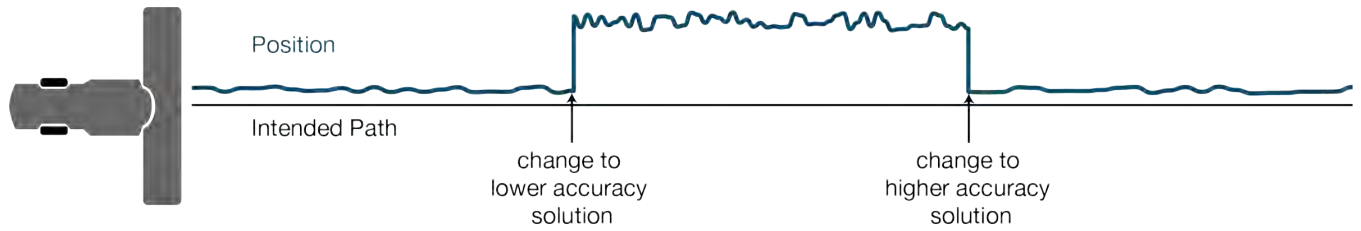

The STEADYLINE feature internally monitors the position offsets between all the GNSS positioning modes present in the receiver. When the current positioning mode becomes unavailable, the receiver transitions to the next most accurate positioning mode.



Refer to the [OEM7 Commands and Logs Reference Manual](#) for log and command details.

3.5.1 Prefer Accuracy

The positioning mode change depends on the accuracy level of the positioning modes.

When the position mode is changing from a more accurate mode to a less accurate mode (e.g., changing from RTK to GLIDE), the receiver uses the position offset calculated to limit a potential real position jump.

When the position mode is changing from a less accurate mode to a more accurate mode (e.g., GLIDE to RTK), the receiver slowly transitions to the new reference position type over the time period specified by the Transition time parameter.

For example, a receiver is configured to do both RTK and GLIDE. If this receiver has a fixed RTK position and experiences a loss of correction data causing the loss of the RTK solution it will immediately apply the offset between the two position modes and uses the GLIDE position stability to maintain the previous trajectory. Over time the GLIDE (or non-RTK) position will experience some drift. Once the RTK position is achieved again the receiver will start using the RTK positions for position stability and will slowly transition back to the RTK positions at a default rate of 0.005 m/s or the time specified in the **STEADYLINE** command.

Figure 15: STEADYLINE Prefer Accuracy

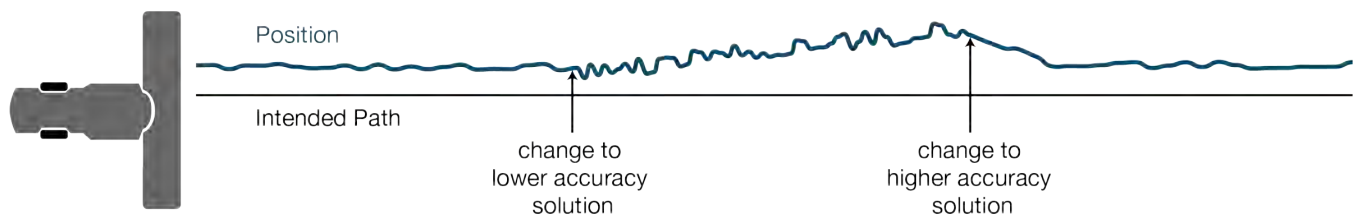

3.6 Enabling SBAS positioning

OEM7 receivers are capable of SBAS positioning. This positioning mode is enabled using the **SBASCONTROL** command:

```
sbascontrol enable auto
```

When the command is entered, the OEM7 receiver automatically tracks the SBAS that is operating in the region (e.g., WAAS or EGNOS) and applies the corrections from the service. On a simulator, leave the test mode parameter off or specify NONE explicitly. For more on SBAS, refer to application note [APN-051 Positioning Modes of Operation](#) (additional Application Notes available at novatel.com/support/support-materials/application-notes) and the known solution [SBAS Positioning](#).

3.7 Enabling Corrections Services and PPP

Hexagon offers Precise Point Positioning (PPP) solutions for many different applications with up to centimetre level positioning accuracy, available as subscription services. See *Receiver Features: Authorization and Subscriptions* on page 152. OEM7 receivers can receive PPP corrections directly from L-band satellites and additionally through an IP interface using NTRIP.

- Land and airborne applications use TerraStar Corrections Services.
- Marine survey and nearshore vessels use Oceanix Corrections Services.
- Deep water marine and exploration use Veripos Corrections Services.

With correction data from a correction services provider and NovAtel's PPP algorithm, NovAtel receivers can achieve sub-metre to centimetre level positioning accuracy. To enable a PPP solution, the following is required:

- a receiver capable of receiving the correction data stream
- a subscription to a supported correction service provider
 - TerraStar Correction Services
To enable PPP with TerraStar Correction Services, see *TerraStar Corrections Services* below.
 - Oceanix Correction Services
To enable PPP with Oceanix Correction Services, see *Oceanix Corrections Services* on page 60.
 - Veripos Correction Services
For information about Veripos, see *Veripos Corrections Services* on page 62.

3.7.1 TerraStar Corrections Services

TerraStar subscriptions

TerraStar Corrections Services subscriptions offer a range of real-time precision positioning services for land and airborne applications leveraging Novatel's Precise Point Positioning (PPP) solution. For details see novatel.com/products/gps-gnss-correction-services/terrestar-correction-services.

- **TerraStar-L**
TerraStar-L provides reliable sub-metre accuracy with excellent pass-to-pass repeatability for basic positioning and navigation applications, with performance specifically tailored for broadacre farming.
- **TerraStar-C PRO**
TerraStar-C PRO provides best in class, 2.5 cm accuracy globally with fast convergence and fast re-convergence after GNSS outages. A premium service for precise navigation and high reliability applications.
- **TerraStar-X Regional**
TerraStar-X Regional provides rapid one minute convergence and 2 cm accuracy in region. The TerraStar-X service subscription also includes TerraStar-C PRO outside the region and RTK ASSIST PRO globally. Precise navigation and high reliability are instantly available.
- **RTK ASSIST**
RTK ASSIST enables OEM7 receivers using RTK to maintain centimetre-level accuracy for up to 20 minutes of RTK correction outages.
- **RTK ASSIST PRO**

RTK ASSIST PRO enables OEM7 receivers using RTK to maintain centimetre-level accuracy for longer RTK correction outages. It also provides independent centimetre-level PPP positioning enabling operations in areas where there is no RTK base or network coverage.

- **SmartNet RTK plus RTK ASSIST**

NovAtel offers HxGN SmartNet RTK network corrections and RTK ASSIST service together as SmartNet+, providing RTK corrections and maintaining centimetre-level accuracy during cellular outages up to 20 minutes.

To use TerraStar Correction Services and obtain a PPP solution, perform the following steps.

1. Ensure the GNSS system has the required components. See *Required components* below.
2. Enable L-band tracking or NTRIP for PPP on the receiver.
See *Enable L-band tracking* on the next page or *NTRIP for PPP* on the next page.
3. Obtain a subscription to the TerraStar Correction Service to be used.
The NovAtel eCommerce system will ensure the required features are authorized or included.

Geogating and Regional Access

For land-based applications, TerraStar subscriptions are geogated to function only on land. A small margin is included around shorelines to ensure it is not blocked near the ocean. These services are marked as *GEOGATED* in the *Region Restriction* fields of the **TERRASTARINFO** log. Land-based TerraStar subscriptions are also limited to a region based on which L-band satellites are in view from the location specified at purchase. See terrastar.net/services/terrastar-coverage-map for coverage. The **LBANDBEAMTABLE** log shows which L-band satellites the receiver is permitted to access.

For airborne or global operations, TerraStar subscriptions without geogating or L-band satellite restrictions are available. These are marked *NONE* in the *Region Restriction* fields of the **TERRASTARINFO** log, and the **LBANDBEAMTABLE** log has access enabled for all satellites.

Contact [NovAtel sales](#) for details.

Required components

To use TerraStar Correction Services, the GNSS system requires the following components:

- A CPT7 or CPT7700
- Receiver firmware that is compatible with TerraStar Correction Services.
 - TerraStar-L – all OEM7 firmware versions
 - TerraStar-C PRO, RTK ASSIST, RTK ASSIST PRO – firmware version 7.05.00 or later. Version 7.08.10 or later provides the best convergence performance and robustness.
 - TerraStar-X Regional – firmware version 7.06.03 or later. Version 7.08.10 or later provides service outside of the region.
- A GNSS antenna capable of receiving L-band signals, an IP connection to the NTRIP stream or a serial connection to an external.

For the best TerraStar performance, select a GNSS antenna that provides full GNSS signal support. (i.e., GPS L1/L2/L5, GLONASS L1/L2, Galileo E1/E5a/E5b/E6 and BeiDou B1C/B2a/B2b/B3)

Refer to our web site novatel.com/products/gps-gnss-antennas for information about NovAtel L-band-capable antennas.



L-band reception is not required if using IP delivered TerraStar Corrections. See [APN-089: IP Delivery for Global TerraStar Corrections](#) for more information.

For instructions on upgrading the OEM7 receiver firmware, see *NovAtel firmware* on page 156.

Enable L-band tracking

The receiver must be powered and tracking an L-band signal from a TerraStar satellite to receive a subscription transmitted as a dispatch message and to receive corrections from the satellites during operation. Alternately see *NTRIP for PPP* below.

Send the **ASSIGNLBANDBEAM** command to configure the receiver to track the L-band signals from TerraStar satellites.

```
ASSIGNLBANDBEAM auto
```

To confirm the receiver is tracking an L-band signal, request the **LBANDTRACKSTAT** log to view the L-band tracking status information.

```
log lbandtrackstat
<LBANDTRACKSTAT USB1 0 54.5 FINESTEERING 2232 421280.000 02000020 29e3 16809
< 5
< "98W" 1545865000 1200 974c 00c2 0 -449.146 40.239 2.8709 160.522 2944 1 1
376832 287 0.0005
< "AORW" 1545845000 1200 974c 00c2 0 -178.422 44.178 4.1159 171.958 3200 0
0 409600 2 0.0000
< "POR" 1545905000 1200 974c 0000 0 643.962 0.000 0.0000 0.000 0 0 0 0 0
0.0000
< "" 0 0 0000 0003 0 0.000 0.000 0.0000 0.000 0 0 0 0 0 0.0000
< "" 0 0 0000 0003 0 0.000 0.000 0.0000 0.000 0 0 0 0 0 0.0000
```

If the receiver is tracking an L-band signal from a TerraStar satellite, the tracking status word (shown in bold in the example above) of the LBANDTRACKSTAT log will be **00c2**. In the example above, the tracking status word indicates that the receiver has locked onto the signal from "98W" and "AORW", but not "POR".



The latest services and coverage can be obtained from novatel.com/products/gps-gnss-correction-services/terrastar-correction-services. For additional information on TerraStar subscriptions, contact NovAtel Customer Service at novatel.com/support or download *APN-087 TerraStar on OEM7* from novatel.com/support/support-materials/application-notes

NTRIP for PPP

TerraStar subscription messages and corrections can be received over an IP connection either in addition to over L-band, for robustness, in place of L-band if using an antenna without L-band reception, or when operating in polar regions outside L-band satellite coverage. For receivers with an Ethernet port, there is an NTRIP client built into the receiver, otherwise use an external NTRIP client to send corrections over another communications port. See *APN-089: IP Delivery for Global TerraStar Corrections* from novatel.com/support/support-materials/application-notes for detailed instructions.

Obtain a subscription

TerraStar subscriptions can be purchased through a NovAtel dealer, [NovAtel eStore](https://novatel.com/eStore), the NovAtel machine to machine (M2M) interface or [NovAtel sales](https://novatel.com/sales). See *Receiver Features: Authorization and Subscriptions* on page 152 for details.

The receiver product serial number (PSN) is needed to obtain a subscription. See *Serial Number, Hardware Version, Software Model, Firmware Version* on page 152.

Required receiver features

TerraStar-L and RTK ASSIST will work with only GPS, but for best performance purchase both GPS and GLONASS constellation support with a model that starts with D, C, T or F. A software model upgrade can be purchased and delivered with the subscription. If needed, the upgrade to dual frequency support will be provided with the subscription.

TerraStar-C PRO requires the PPP positioning feature. If the receiver does not already have the PPP feature authorized, you will be prompted to purchase a PPP subscription or model upgrade to be delivered with the subscription. A model name with P, R or B in the fourth character includes the PPP feature.

RTK ASSIST, RTK ASSIST PRO and TerraStar-X (which includes RTK ASSIST PRO) all extend the RTK positioning feature. If the receiver does not already have the RTK feature authorized, you will be prompted to purchase an RTK subscription or model upgrade to be delivered with the subscription. The RTK feature shows as an R or B in the fourth character of the model name.

TerraStar-C PRO, RTK ASSIST PRO and TerraStar-X all include an upgrade to all constellation, all frequency support (as supported by the hardware) with the subscription. This appears as a model starting with FF or MF for the duration of the subscription.

Verify the subscription status

When a service is active, you can confirm the service is enabled and corrections are being received with the **TERRASTARSTATUS** log:

```
log terrastarstatus
```

```
<TERRASTARSTATUS USB1 0 57.0 FINESTEERING 2232 423531.436 02000020 32bc 16809
<    ENABLELOCKED 0 IN_RANGE DISABLED
```

The first field after the log header will be **ENABLE** to indicate the TerraStar service is authorized. The second field after the log header will be **LOCKED** to indicate the decoder is locked to the data format and corrections are being received..

Monitor PPP convergence

The PPP position calculated using TerraStar Correction Services is not ready for use until the PPP solution has converged. To monitor the PPP convergence, request the **PPPPOS** log:

```
log ppppos ontime 1
```

```
<PPPPOS USB1 0 47.5 FINESTEERING 2232 424797.000 02000020 9078 16809
<    SOL_COMPUTED PPP_CONVERGING 51.15043905734 -114.03067597608 1096.6201 -
17.0001 WGS84 0.6791 0.4277 1.7640 "TSTR" 17.000 0.000 34 34 34 33 00 00 7f 37
<PPPPOS USB1 0 58.5 FINESTEERING 2232 424886.000 02000020 9078 16809
<    SOL_COMPUTED PPP 51.15043767399 -114.03067692975 1097.4541 -17.0001 WGS84
0.2498 0.1951 0.4824 "TSTR" 16.000 0.000 34 34 34 33 00 00 7f 37
```

Initially the position type will report **PPP_CONVERGING** for TerraStar-C Pro, TerraStar-X, and RTK ASSIST PRO, or **PPP_BASIC_CONVERGING** for TerraStar-L. After the PPP solution has converged, the position type in the **PPPPOS** log will change to **PPP** for TerraStar-C PRO, TerraStar-X, and RTK ASSIST PRO, or **PPP_BASIC** for TerraStar-L. RTK ASSIST does not provide PPPPOS output.

Subscription Managed Channel Configuration

To ensure the fastest convergence and most robust solution, an all constellation, all frequency channel configuration is included with TerraStarC PRO, TerraStarX and RTK ASSIST PRO service. By default **TERRASTARAUTOCHANCONFIG** is enabled and the best possible channel configuration number for the service is automatically selected, overriding **SELECTCHANCONFIG**. The best possible channel configuration available depends on the hardware, as given in the table below.

Receiver	Constellations and frequencies (Model Prefix)	Chan Config Number
CPT7700	FF	7
CPT7	MF	6



For information about channel configurations, refer to the **SELECTCHANCONFIG** command and the **CHANCONFIGLIST** log.

Additional information

For more information on TerraStar Correction Services, refer to *APN-087: TerraStar on OEM7* available from novatel.com/support/support-materials/application-notes

3.7.2 Oceanix Corrections Services

An Oceanix-H Near-shore corrections service subscription provides real-time precision positioning services for marine vessels operating within 10 km of shore, leveraging Novatel's Precise Point Positioning (PPP) solution. Oceanix-H provides best in class, 2.5 cm accuracy globally with fast convergence. A premium service for precise navigation and hydrographic measurement applications.

For more information about Oceanix services, visit novatel.com/products/gps-gnss-correction-services/oceanix-correction-services.

To use Oceanix Corrections Services and obtain a PPP solution, perform the following steps.

1. Ensure the GNSS system has the required components. See *Required components* below.
2. Enable L-band tracking or NTRIP for PPP on the receiver. See *Enable L-band tracking* below. or *NTRIP for PPP* on the next page.
3. Obtain a subscription to Oceanix Correction Services.

The NovAtel eCommerce system will ensure the required receiver features are authorized or included. See *Oceanix Corrections Services* above.

Required components

To use Oceanix Corrections Services, the GNSS system requires the following components:

- A (CPT7 or CPT7700)
- OEM7 receiver firmware version 7.08.10 or later.

For instructions on upgrading the OEM7 receiver firmware, see *NovAtel firmware* on page 156.

- A GNSS antenna capable of receiving L-band signals, an IP connection to the NTRIP stream or a serial connection to an external NTRIP client.

For the best Oceanix performance, select a GNSS antenna that provides full GNSS signal support. (i.e., GPS L1/L2/L5, GLONASS L1/L2, Galileo E1/E5a/E5b/E6 and BeiDou B1C/B2a/B2b/B3)

Refer to our web site novatel.com/products/gps-gnss-antennas for information about NovAtel L-band-capable antennas.

Enable L-band tracking

The receiver must be powered and tracking the L-band signal from an Oceanix satellite to receive a subscription transmitted as a dispatch message and to receive corrections from the satellites during operation. Alternately see *NTRIP for PPP* on the next page.

Send the **ASSIGNLBANDBEAM** command to configure the receiver to track the Oceanix satellite.

```
ASSIGNLBANDBEAM auto
```

To confirm the receiver is tracking of an L-band signal, request the **LBANDTRACKSTAT** log to view the L-band tracking status information.

```
log lbandtrackstat
<LBANDTRACKSTAT USB1 0 54.5 FINESTEERING 2232 421280.000 02000020 29e3 16809
< 5
< "98W" 1545865000 1200 974c 00c2 0 -449.146 40.239 2.8709 160.522 2944 1 1
376832 287 0.0005
< "AORW" 1545845000 1200 974c 00c2 0 -178.422 44.178 4.1159 171.958 3200 0
0 409600 2 0.0000
< "POR" 1545905000 1200 974c 0000 0 643.962 0.000 0.0000 0.000 0 0 0 0 0
0.0000
< "" 0 0 0000 0003 0 0.000 0.000 0.0000 0.000 0 0 0 0 0 0.0000
< "" 0 0 0000 0003 0 0.000 0.000 0.0000 0.000 0 0 0 0 0 0.0000
```

If the receiver is tracking an L-band signal from an Oceanix satellite, the tracking status word (shown in bold in the example above) of the LBANDTRACKSTAT log will be **00c2**. In the example above, the tracking status word indicates that the receiver has locked onto the signal from "98W" and "AORW", but not "POR".



The latest services and coverage can be obtained from novatel.com/products/gps-gnss-correction-services/oceanix-correction-services. For additional information on Oceanix subscriptions, contact NovAtel Customer Service at novatel.com/support.

NTRIP for PPP

Oceanix subscription messages and corrections can be received over an IP connection either in addition to over L-band, for robustness, in place of L-band if using an antenna without L-band reception or when operating in polar regions outside L-band satellite coverage. For receivers with an Ethernet port there is an NTRIP client built into the receiver, otherwise use an external NTRIP client to send corrections over another communications port. See *APN-089: IP Delivery for Global TerraStar Corrections* from novatel.com/support/support-materials/application-notes for detailed instructions.

Obtain a subscription

Oceanix subscriptions can be purchased through a NovAtel dealer, [NovAtel eStore](https://novatel.com/eStore), the NovAtel machine to machine (M2M) interface or [NovAtel sales](https://novatel.com/sales). See *Receiver Features: Authorization and Subscriptions* on page 152 for details.

The receiver product serial number (PSN) is needed to obtain a subscription. See *Serial Number, Hardware Version, Software Model, Firmware Version* on page 152.

Verify the subscription status

When the service is active, you can confirm that the service is enabled and corrections are being received with the **OCEANIXSTATUS** log:

```
log oceanixstatus
<OCEANIXSTATUS USB1 0 51.5 FINESTEERING 2232 495334.510 02000020 049a 16809
< ENABLE LOCKED IN_REGION
```

The first field will be **ENABLE** to indicate the Oceanix service is currently authorized. The second field will be **LOCKED** to indicate the decoder is locked to the data format and corrections are being received.

Monitor PPP convergence

The PPP position calculated using Oceanix Correction Services is not ready for use until the PPP solution has converged.

To monitor the PPP convergence, request the **PPPPOS** log:

```
log ppppos ontime 1

<PPPPOS USB1 0 47.5 FINESTEERING 2232 424797.000 02000020 9078 16809
< SOL_COMPUTED PPP_CONVERGING 51.15043905734 -114.03067597608 1096.6201 -
17.0001 WGS84 0.6791 0.4277 1.7640 "OCXH" 17.000 0.000 34 34 34 33 00 00 7f 37

<PPPPOS USB1 0 58.5 FINESTEERING 2232 424886.000 02000020 9078 16809
< SOL_COMPUTED PPP 51.15043767399 -114.03067692975 1097.4541 -17.0001 WGS84
0.2498 0.1951 0.4824 "OCXH" 16.000 0.000 34 34 34 33 00 00 7f 37
```

Initially the position type will report *PPP_CONVERGING*. After the PPP solution has converged, the position type will change to *PPP*.

Subscription Managed Channel Configuration

To ensure the fastest convergence and most robust solution, an all constellation, all frequency channel configuration is included with Oceanix-H service. By default **TERRASTARAUTOCHANCONFIG** is enabled and the best possible channel configuration number for the service is automatically selected, overriding **SELECTCHANCONFIG**. The best possible channel configuration available depends on the hardware, as given in the table below.

Receiver	Constellations and frequencies (Model Prefix)	Chan Config Number
CPT7700	FF	7
CPT7	MF	6



For information about channel configurations, refer to the **SELECTCHANCONFIG** command and the **CHANCONFIGLIST** log.

3.7.3 Veripos Corrections Services



Subscriptions to the Veripos Apex marine services must be obtained directly from Veripos. A unit with a marine subscription can not be switched to a land subscription and vice versa.

A subscription is required to use the [Veripos services](#) for offshore marine applications. Contact Veripos sales at veripos.com/support to obtain a Service Access License (SAL) number.

To activate the service, contact the Veripos Support at veripos.com/support. Provide the SAL number and the receiver's Veripos Serial Number (VSN). To obtain the receiver-specific VSN, enter the following command:

```
log veriposinfo

<VERIPOSINFO USB1 0 50.0 FINESTEERING 2232 490175.302 02000020 2bd7 16809
< 557954 UNASSIGNED 80000733 "6"
```

The log displays the VSN in the first field following the log header (557954 in the example above) and also displays the status of your subscription.

To activate a subscription, the receiver must be powered and tracking an L-band Veripos satellite prior to the planned activation time. Use the **ASSIGNLBANDBEAM** command to configure the receiver to track the Veripos satellite.

```
assignlbandbeam auto
```



The latest services and coverage can be obtained from www.veripos.com. For additional information on Veripos activation, contact Veripos Customer Service at veripos.com/support.

3.8 RTK ASSIST Services

RTK ASSIST and RTK ASSIST PRO are subscription features that enable centimetre-level accuracies to be maintained through extended RTK corrections outages using TerraStar Corrections Services and the NovAtel Precise Point Positioning (PPP) engine. RTK ASSIST will maintain RTK-dependent operations through RTK corrections outages for as long as 20 minutes. RTK ASSIST PRO will maintain RTK dependent operation through unlimited RTK corrections outages. RTK ASSIST PRO also enables independent centimetre-level PPP positioning in areas where there is no RTK base or network coverage.

Hardware platform and antenna requirements, obtaining a subscription and confirming operation is described in *TerraStar Corrections Services* on page 56.

RTK ASSIST services are available as soon as the rover receiver has at least one valid RTK solution and has received the RTK ASSIST correction data. If an RTK correction outage occurs, then RTK ASSIST will maintain RTK mode until the subscription-permitted RTK ASSIST duration is exceeded. A shorter, user-defined RTK ASSIST time out can also be set using the **RTKASSISTTIMEOUT** command. Normal RTK operation will seamlessly resume if RTK corrections are restored at any point while RTK ASSIST is operating.

RTK ASSIST will report the RTK solution type that was present before RTK corrections were lost, unless the estimated solution standard deviation exceeds the threshold set by the **RTKINTEGGERCRITERIA** command. If this occurs, then integer RTK solutions will be downgraded to their float RTK equivalent.

RTK ASSIST is enabled by default, but can be disabled using the **RTKASSIST** command. To monitor the status of RTK ASSIST, view the **RTKASSISTSTATUS** log.

Refer to the [OEM7 Commands and Logs Reference Manual](#) for log and command details.



RTK ASSIST typically provides 4 cm accuracy. However, if the RTK outage occurs during the first 30 minutes of receiver operation, the position accuracy provided by RTK ASSIST may be lower.



Additional information about enabling and using RTK ASSIST is available in [APN-073: RTK ASSIST & RTK ASSIST PRO](#) (available from our website: novatel.com/support/support-materials/application-notes).

3.9 Precision Time Protocol

The Precision Time Protocol (PTP) feature is used to synchronize the clocks on the network to which the receiver is connected.



PTP is available on OEM729, OEM7600, OEM7700, OEM7720, PwrPak7, CPT7, CPT7700, SMART7-I and SMART7-SI receivers.

3.9.1 Configuring PTP

The general use and configuration of a PTP network is beyond the scope of this document. The following is an overview of the steps to configure an OEM7 receiver to be part of a PTP network.

1. Configure the Ethernet settings on the receiver. Refer to *Ethernet configuration* on page 133 for information about configuring the receiver.

If using a dynamic IP address, ensure the network switch has DHCP enabled.

2. Use the **PTPMODE** command to enable PTP on the receiver.

```
PTPMODE ENABLE
```

3. Use the **PTPPROFILE** command to select the PTP profile used by the receiver.
4. Use the **PTPTIMESCALE** command to select the time scale used on the PTP network.

3.9.2 Configuration notes

- Configure all of the PTP clocks to be synchronized on the network, so the transport mechanism, domain number, delay mechanism, best master clock algorithm, sync interval, and announce interval match.
- The receiver clock is never changed to be synchronized with another master clock. The difference between the receiver clock and the master clock is reported in the **PTPDELTA** log.
- Configure the values of priority1 and priority2 for each PTP clock to ensure that the appropriate clock is selected as the best master under the appropriate conditions.
- For best synchronization performance, all PTP clocks must be connected only to PTP aware networking appliances (hubs, switches and routers). Specifically, all connections must be made via PTP boundary or transparent clocks.

At a minimum, all networking appliances must support the distribution of PTP multicast messages. Failing to use PTP boundary or transparent clocks for all interconnections will reduce the synchronization accuracy. However, the PTP protocol will continue to synchronize the clocks within the limits of the variability of PTP message transit times.

Consult the user documentation for the networking appliances to determine if the devices support PTP and how to configure them for PTP support.

- If PTP is enabled on multiple receivers and all receivers are reset, it is expected that all receivers will report MASTER for a few seconds before having all but one receiver switch to report PASSIVE/SLAVE in the **PTPDELTA** log.
- If the master clock is not configured using the **PTPPROFILE** command (i.e. the PTPPROFILE command is left at the default value), the PTP algorithm will decide which device is the master regardless of which device is connected first.
- A peer-to-peer PTP network is designed to work with 2 clocks per subnet. Having more than two clocks will cause issues with PTP.
- If using any ITU profile, which is a forced PTP MASTER state, it is normal to see other receivers with the MASTER state. PTP will still only synchronize to the best clock.

3.9.3 Monitoring the PTP status

The status of PTP on the receivers is monitored using the **PTPDELTA**TIME log. To check the status of PTP:

1. Collect the **PTPDELTA**TIME log on each receiver.
2. Check the **PTP State** field of the PTPDELTAIME log for each receiver to ensure that only one device is reporting MASTER and all other devices are reporting PASSIVE or SLAVE (unless multiple masters have been specifically configured on the system).
3. Check the **Time Offsets Valid** field of the PTPDELTAIME log. All of the receivers should report a value of TRUE.
4. It is also beneficial to collect the **TIME** log and confirm the clock status of each receiver.

3.9.4 Troubleshooting

Networking issues are a primary cause of the PTP network not working as expected. While troubleshooting networking issues is beyond the scope of this manual, the following tips can be helpful starting points.

- Ensure that all receivers/devices are connected to the switch and are on the same subnet.
- Ensure IGMP snooping is turned off on the network switches (if that feature is available on the switches).
- Check the multicast address groups (IGMP querying) on the network switches.
- Network monitoring applications (such as the free program Wireshark) can be used to filter and view PTP specific messages. This can help to determine which devices are connected and sending PTP messages.

3.10 Transferring time between receivers

The **ADJUST1PPS** command is used as part of the procedure to transfer time between receivers. The number of Pulses Per Second (PPS) is always set to 1 with this command. It is typically used when the receiver is not adjusting its own clock and is using an external reference frequency.

The **TIMESYNC** log is also used to synchronize time between receivers. It contains a time status field that may show COARSE or FINE, among others. For a complete list of the time status values and definitions, refer to GPS Reference Time Status in the [OEM7 Commands and Logs Reference Manual](#).

Procedures to transfer time on the next page provides details on the time transfer procedure. Terms used in the procedure are defined in *Time definitions* below. Refer also to the **ADJUST1PPS** command and the **TIMESYNC** log in the [OEM7 Commands and Logs Reference Manual](#).

3.10.1 GPS to receiver time synchronization

Receiver time synchronization with GPS time does not occur until the receiver locks onto the first satellite. The GPS L1 signal has two main streams of data modulated on the carrier. These data streams are the C/A code (1.023 MHz rate) and the P(Y) code (10.23 MHz rate). Additionally, a navigation message (at a 50 Hz rate) contains GPS satellite data including the ephemeris, clock corrections and constellation status. This navigation message is encoded on both the C/A and P(Y) codes. The navigation message is transmitted via individual subframes and each subframe is 300 bits in length. With the 50 Hz data bit rate there is a new subframe transmitted every six seconds.

3.10.2 Time definitions

The following are related definitions:

Coarse Time

Each subframe contains the transmit time of the next subframe in seconds of GPS Time of Week (TOW). After

the first subframe is collected and decoded by the receiver, an approximate calculation of the receiver clock offset can be made. The receiver clock offset is the difference between GPS time and internal receiver time. The calculation is based on subframe transmit time and the approximate propagation time from the satellite signal to the receiver. The position of the satellite and receiver clock offset are used to re-initialize the seconds counter on the receiver, resulting in receiver/GPS time synchronization. The accuracy of the receiver time is expected to be within 30 milliseconds (ms) of GPS time. This initial synchronization is referred to as coarse time and is indicated by COARSE in the time status field of the **TIMESYNC** log.

Fine Time

When at least four satellites are acquired to calculate the antenna position, a more accurate estimate of the receiver clock offset is calculated. The new receiver clock offset is used to synchronize the receiver clock even closer to GPS time. This is referred to as fine time and appears as FINE or FINESTEERING in the time status field of the **TIMESYNC** log. Fine time accuracy is a function of the GPS constellation status and is influenced by external receiver RF delay. For the Standard Position Service (SPS) the time accuracy is specified as 20 ns (1 sigma) with internal compensation.

Fine Clock

An OEM7 receiver that is tracking satellites and has a FINE or FINESTEERING receiver clock state.

Cold Clock

An OEM7 receiver that needs to have its clock synchronized with the Fine receiver. It may have any clock state (except FINE or FINESTEERING) that includes UNKNOWN.

Warm Clock

An OEM7 receiver that has its clock adjusted to greater than 500 ms. Refer to the **TIME** log to view the clock offset.



The [OEM7 Commands and Logs Reference Manual](#) contains details of the logs mentioned above.

3.10.3 Procedures to transfer time

These procedures are used to transfer time between a fine clock and a cold or warm clock GPS receiver.



When connecting two receivers to transfer time, disable responses on the COM port used to connect the receivers by issuing the following command on both receivers:

```
interfacemode comX novatel novatel off
```

Where comX is the port used on the receiver.

Transfer COARSE time (<10 ms) from a Fine clock to a Cold clock GPS receiver

1. Connect a COM, USB or Ethernet port from the fine clock receiver to the cold clock receiver (for example, COM2 on the fine clock receiver to COM3 on the cold clock receiver) as shown in *Figure 16: Transfer COARSE time from Fine clock to Cold clock receiver* on the next page. Configure both ports to the same baud rate and handshaking configurations.
2. Issue the following command to the fine clock receiver:

```
log com2 timesyncb ontime 1
```
3. Issue the following command to the cold clock receiver:

```
adjust1pps time
```

When the cold clock receiver receives the **TIMESYNC** log, it sets its clock with a 100 ms transfer delay allowance.

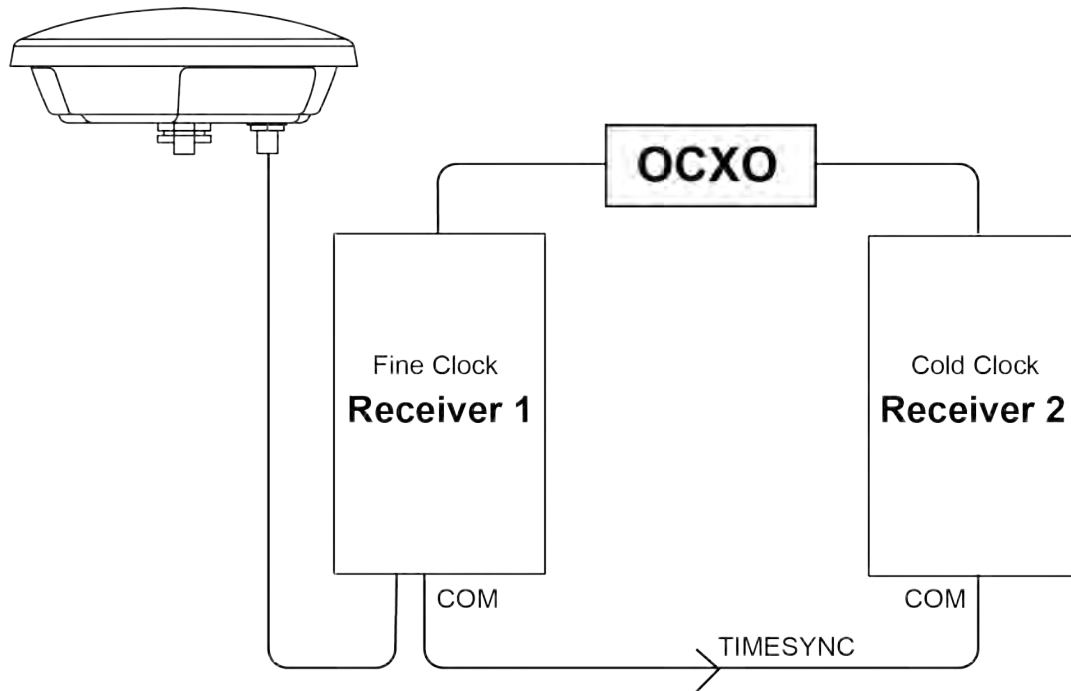
Figure 16: Transfer COARSE time from Fine clock to Cold clock receiver

Transfer FINE time (<50 ns) from a Fine clock to a Cold clock GPS receiver

1. Connect a COM, USB or Ethernet port from the fine clock receiver to the cold clock receiver (for example, COM2 on the fine clock receiver to COM3 on the cold clock receiver), as shown in *Figure 17: Transfer FINE time from Fine clock to Cold clock receiver* on the next page. Configure both ports to the same baud rate and handshaking configurations.
2. On CPT7 and CPT7700 receivers, issue the following command to enable the Mark 1 input (Event1) of the cold clock receiver.

```
EVENTINCONTROL MARK1 ENABLE
```

3. Issue the following command to the fine clock receiver:

```
log com2 timesyncb ontime 1
```

4. Connect the 1PPS signal of the fine clock receiver to the Mark 1 input (Event1) of the cold clock receiver.
5. Issue the following command to the cold clock receiver:

```
adjust1pps markwithtime
```

When the cold clock receiver receives the 1PPS event from the fine clock receiver, it checks to see if a valid **TIMESYNC** log has arrived within 200 ms of the last 1PPS event. If so, it sets the cold clock receiver clock to the time of the fine clock receiver. See *Figure 19: 1 PPS alignment* on page 69.

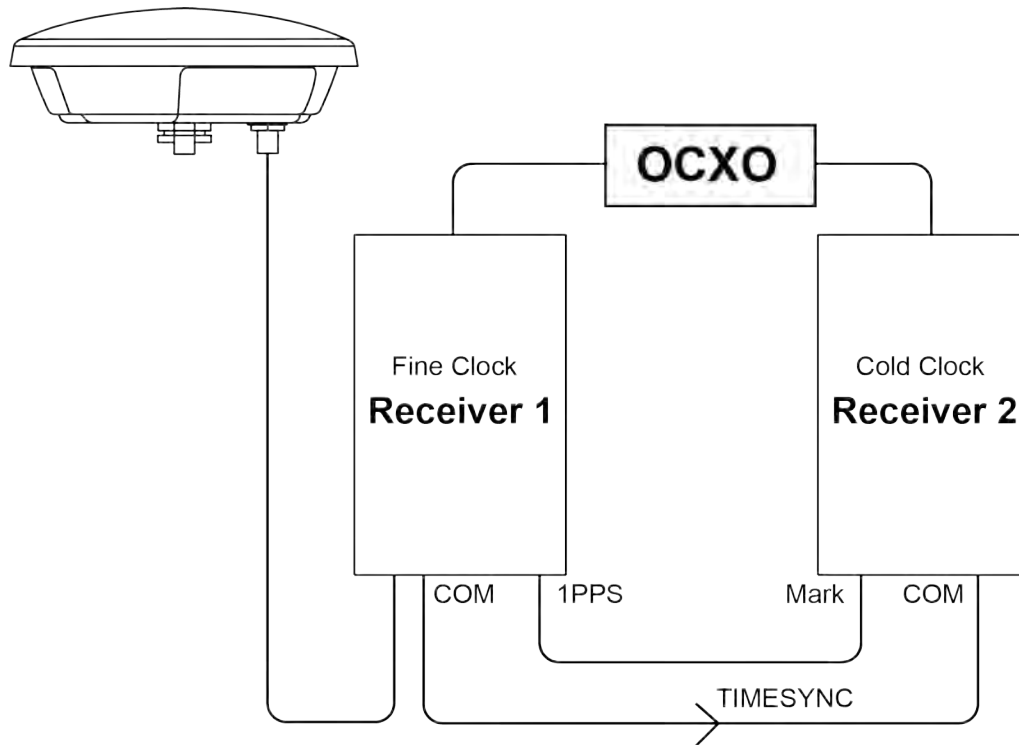
Figure 17: Transfer FINE time from Fine clock to Cold clock receiver

Transfer FINE time from a Fine clock to a Warm clock GPS receiver

1. Connect the 1 PPS signal of the fine clock receiver to the Mark 1 input (Event1) of the warm clock receiver as shown in *Figure 18: Transfer FINE time from Fine clock to Warm clock receiver* on the next page.
2. On CPT7 and CPT7700 receivers, issue the following command to enable the Mark 1 input (Event1) of the warm clock receiver.

```
EVENTINCONTROL MARK1 ENABLE
```

3. Issue the following command to the warm clock receiver:

```
adjust1pps mark
```

The phase of the warm clock receiver clock is adjusted by the fractional measurement of the fine clock receiver's 1 PPS mark input event. In other words, it synchronizes the warm clock receiver's 1 PPS to the incoming 1 PPS of the fine clock receiver. It does not adjust the one second TOW counter or the receiver's week number. This procedure is used to make small corrections to the warm clock receiver's clock.

Figure 18: Transfer FINE time from Fine clock to Warm clock receiver

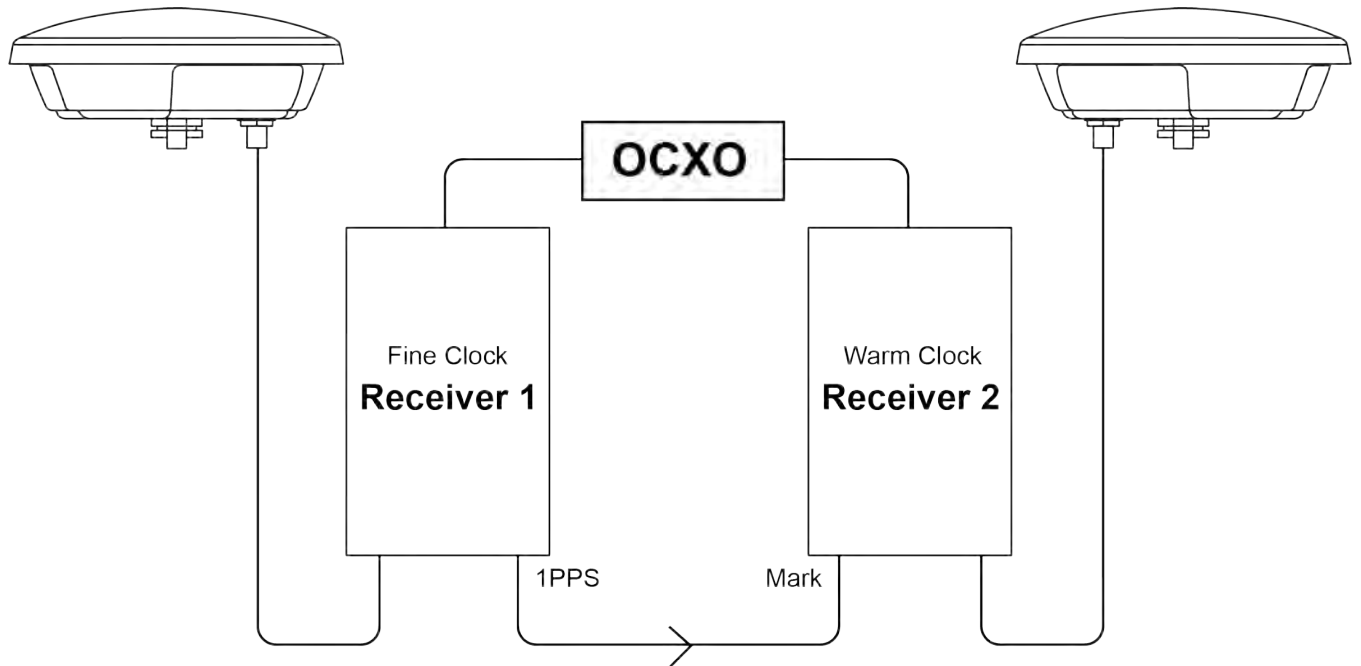

If Receiver 2 is not in coarsetime, the input is ignored.

Figure 19: 1 PPS alignment

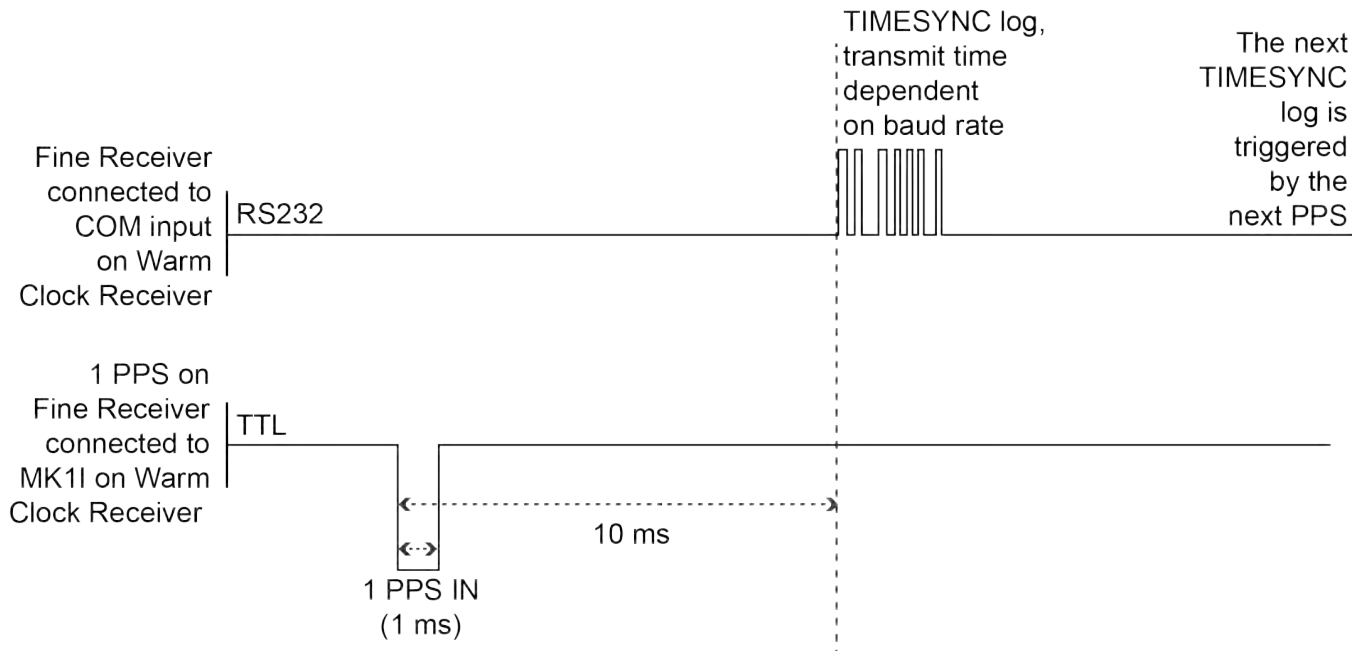



The examples shown in *Figure 16: Transfer COARSE time from Fine clock to Cold clock receiver* on page 67, *Figure 17: Transfer FINE time from Fine clock to Cold clock receiver* on page 68 and *Figure 18: Transfer FINE time from Fine clock to Warm clock receiver* on the previous page are for the transfer of time. If a position is needed, the receiver must be tracking satellites and must have a valid almanac.

3.11 Interference Toolkit

The Interference Toolkit (ITK) feature monitors, quantifies and removes interference sources to prevent interference from impacting receiver performance.

Using the Interference Toolkit, you can monitor the Radio Frequency (RF) spectrum in a range of frequencies around the GNSS signals that are being received by the OEM7 receiver. If an interference signal is detected, information about the interference is output in the **ITDETECTSTATUS** log. More information about the interference signal can be determined by plotting the information obtained.

Signals available are model dependent. A variety of mitigation techniques are available. Contact novatel.com/contactus/sales-offices to activate full mitigation features.

3.11.1 Monitoring GNSS signals

By default, interference detection is enabled. Detection can be disabled/enabled as needed. See *Disable/Enable detection* on page 72 for instructions. Detected interference can be viewed and different tracking modes with possible additional filters can be applied to mitigate the interference using NovAtel Application Suite. Detected interference details can also be logged and analysed using the command line interface.

There are two types of interference detection available, Spectral Analysis Detection and Statistical Analysis Detection.



NovAtel recommends using the default settings for Interference Toolkit whenever possible.

Spectral analysis detection

Spectral Analysis Detection is focused on in-band, near-band, and strong out-band interference detection.

OEM7 uses receiver gain calibration data that is stored in receiver memory at receiver start-up. The calibration data is used to estimate the antenna gain before the receiver, as well as generate interference free spectrum reference for spectral analysis detection. The receiver assumes that the receiver is in an interference free environment during start-up and the antenna is connected to the receiver and powered up.



When using the Interference Toolkit, the receiver must be reset when the GNSS antenna is connected or disconnected.



If a known interference source is present at the receiver start up, it's strongly recommended that users enter the calibrated receiver input gain using the **RFINPUTGAIN** command.

Measuring the RF input gain



This section is intended for advanced users.

The **RFINPUTGAIN** command allows users to enter a more accurate receiver input condition, which is considered as a calibrated receiver input condition, and is used for interference detection. This command supports different values for L1, L2, L5, and L-band and is recommended when there is a known strong interference present at receiver start up.

To calibrate the receiver input level, use a standard spectrum analyser to measure the receiver input noise density in dBm/Hz. Make sure the pre-amplifier is turned on in Spectrum Analyser under “Amplitude”. Place the Marker around L1, L2, L5, or L-band frequency region and select “noise density” under “Marker Function”.

$RFINPUTGAIN = \text{Receiver Input Noise Density (dBm/Hz)} - \text{Typical Thermal Noise KT of } -174\text{dBm/Hz}$,
where:

$K = 1.38\text{E-}23\text{w-sec/K}$

$T = 290\text{ k}$.

For example, if the receiver input noise density measured at L1 is -144dBm/Hz,

$RFINPUTGAIN = -144 - (-174) = 30\text{dB}$ for L1 path.

Alternatively, if a spectrum analyser is not available, the RFINPUTGAIN can be obtained using the cascaded RF gain before the receiver plus LNA noise figure (NF), including LNA gain in antenna, in-line amplifier gain (if applicable), RF cable or distribution loss prior to receiver input connector. A typical GNSS active antenna with reasonable quality has a noise figure of ~2dB.

$RFINPUTGAIN = \text{Cascaded Gain before receiver} + \text{LNA NF}$

For example, if system cumulative gain measured before receiver is ~25dB, and LNA NF is around 2dB, the $RFINPUTGAIN = 27\text{dB}$.

```
RFINPUTGAIN L1 27
```

```
RFINPUTGAIN L2 27
```

```
RFINPUTGAIN L5 27
```

```
RFINPUTGAIN LBand 27
```

Statistical analysis detection

Statistical Analysis Detection is focused on out of band interference detection. It is supplementary to the Spectrum Analysis Detection and is useful when interference is outside the analog passband of the receiver and creating distortion that may not be visible to Spectrum Analysis Detection until the interference is very strong.

The Statistical Analysis Detection is designed as a sensitive detection tool. Out of band mitigation does not impose much penalty when enabled and it brings awareness to unintentional interferences next to GNSS operations.



Spectral Analysis Detection takes precedent over Statistical Analysis Detection. If the same interference is detected by both detectors, only Spectral Analysis Detection is used to report the interference status.

3.11.2 Disable/Enable detection

The interference detection feature can be enabled/disabled from the command line using the **ITDETECTCONFIG** command.

To disable interference detection, enter:

```
ITDETECTCONFIG none
```

To enable interference on all RF paths, enter :

```
ITDETECTCONFIG all
```

Interference detection can also be enabled on individual RF paths. See the **ITDETECTCONFIG** command for details.

The sensitivity level for setting the *Jammer Detected* bit in the *Receiver Status* word in the log headers can be configured using the **ITWARNINGCONFIG** command. By default it is set to the least sensitive setting, meaning that interference needs to be severe for this bit to be set.

3.11.3 Monitoring signals using the command line

The **ITDETECTSTATUS** log lists all detected interference signals. For interference detected by spectral analysis, the log also provides the centre frequency and bandwidth of the interference signal. With this information, a filter can be configured to mitigate the interference.



Due to the high volume of data, a higher bandwidth medium, such as USB or Ethernet, is recommended when monitoring signals using the Interference Toolkit.

Example:

```
LOG ITDETECTSTATUS onchanged

#ITDETECTSTATUSA,USB2,0,74.0,FINESTEERING,1982,430605.267,0200c000,7fdb,32768;
3,L1,STATISTICANALYSIS,-0.718,29.167,0.126,12.797,00000000,00000000,00000000,
L2,SPECTRUMANALYSIS,1249.961,71.191,-56.769,-132.907,00000000,00000000,00000000,
L2,SPECTRUMANALYSIS,1289.512,1.978,-75.967,-138.493,00000000,00000000,00000000
*87381101
```

In the above example, there are three interference signals detected:

- Out of band interference near L1 (STATISTICANALYSIS)
- Interference in the L2 band at 1249.961 MHz
- Interference in the L2 band at 1289.512 MHz

To view details about the signals that are being received by the OEM7 receiver and determine if there is an interference signal within the GNSS signals, use the **ITSPECTRALANALYSIS** command to enable and configure the spectral analysis. The spectrum can then be viewed by plotting the PSD samples in the **ITPSDFINAL** log. NovAtel Application Suite can also be used to view the spectrum. See *Monitoring signals using NovAtel Application Suite* on the next page.

Example:

```
ITSPECTRALANALYSIS PREDECIMATION GPSL1 200 2K 1 1

LOG ITPSDFINAL onnew
```

When logged, incoming signal information is collected at the rate specified in the **ITSPECTRALANALYSIS** command.



Pre-decimation – Raw analog-to-digital converter signals.
 Post-decimation – Analog-to-digital converted signal for the specific signal encoder path. This gives a narrower view of the incoming signal.

3.11.4 Monitoring signals using NovAtel Application Suite



Due to the high volume of data, a higher bandwidth medium, such as USB or Ethernet, is recommended when monitoring signals using the Interference Toolkit.

Start NovAtel Application Suite and open a *Manage* connection to the OEM7 receiver.

Click **Tools** and select **Interference Toolkit**. The *Interference Toolkit* window opens. The following example shows a typical signal.

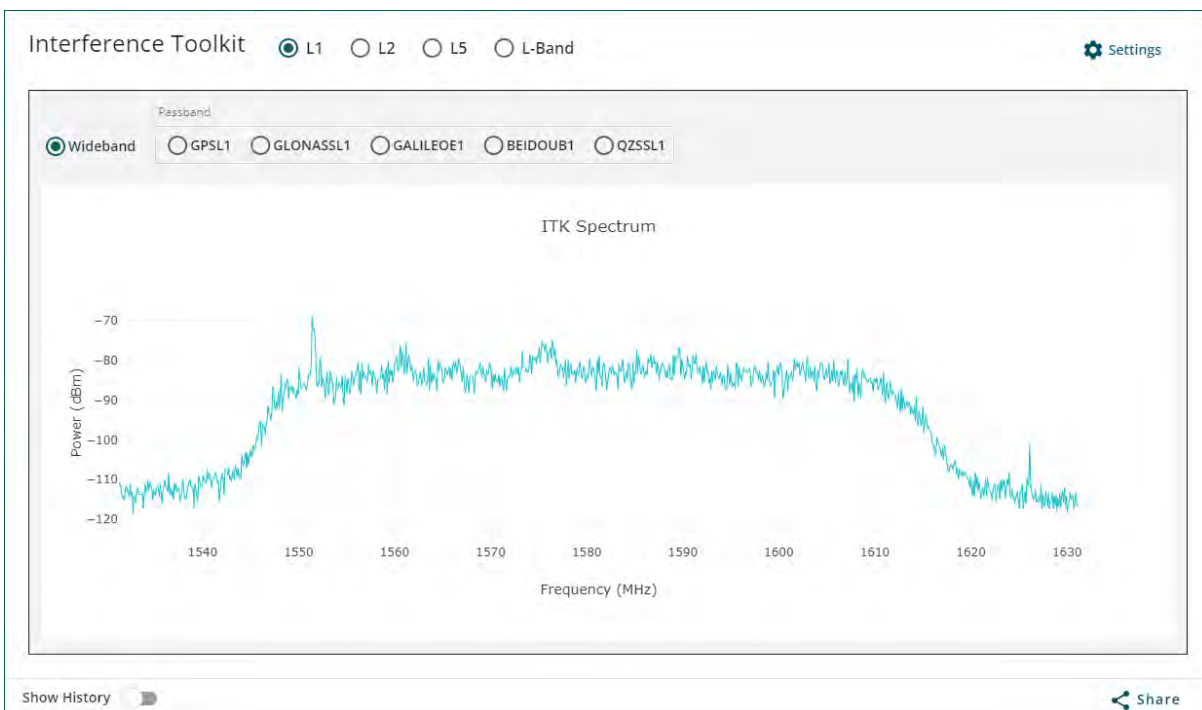

Placing the cursor over any place in the signal band will display additional information regarding that location in the signal band.

For information about using the Interference Toolkit in NovAtel Application Suite, refer to docs.novatel.com/Tools/Content/Manage/InterferenceToolKit.htm.

3.11.5 Remove interference signals

If an interference signal is present, the Interference Toolkit can reduce or eliminate the impact on GNSS tracking using the programmable High Dynamic Range (HDR), Bandpass or Notch filters.

Contact novatel.com/contactus/sales-offices to obtain mitigation functionality.

High Dynamic Range mode

The High Dynamic Range (HDR) mode enables special signal processing to remove distortions from the spectrum, providing a cleaner signal. This optimizes the Automatic Gain Control (AGC) to prevent interfering

signals from drowning out the GNSS signals. HDR mode works well against wide band and out-of-band interferers. HDR mode can be combined with bandpass and notch filters, but does draw more power.

To configure HDR mode, use the **ITFRONTENDMODE** command. HDR mode can also be enabled using NovAtel Application Suite.

Notch filter

The Interference Toolkit notch filter reduces the signal power in a narrow frequency band. This type of filter is useful for reducing the signal power of a single, narrow band interference signal. Note that the narrowest possible filter should be used to maintain the maximum amount of overall signal power.

To configure a notch filter, use the **ITPROGFILTCONFIG** command. A notch filter can also be configured using NovAtel Application Suite.

Bandpass filter

The Interference Toolkit bandpass filter reduces the signal power of all incoming signals at the upper and lower end of the GNSS signal band starting at the requested cut-off frequency. This type of filter is good for reducing single or multiple interference signals at the edges of the signal band.

When a bandpass filter is applied to this signal, the upper and lower ends of the signal band are filtered out to reduce the signal power of the interference signal.

To configure a bandpass filter, use the **ITPROGFILTCONFIG** command or the **ITBANDPASSCONFIG** command. A bandpass filter can also be configured using NovAtel Application Suite.

3.11.6 Interference Toolkit commands and logs

The following are the commands and logs used by the Interference Toolkit to monitor, apply filters and mitigate interference. Commands and logs with the ✓ are available by default. Contact novatel.com/contactus/sales-offices to activate full mitigation features.

Commands		
ITBANDPASSCONFIG		Configures a bandpass filter on the receiver.
ITDETECTCONFIG	✓	Enables or disables automatic interference detection on the receiver.
ITFRONTENDMODE		Configures the front end mode for each RF path to use the default tracking mode or change to High Dynamic Range (HDR) mode.
ITPROGFILTCONFIG		Configures filtering on the receiver to be either a notch filter or a bandpass filter.
ITSPECTRALANALYSIS	✓	Configures and enables spectral analysis on the receiver.
ITWARNINGCONFIG	✓	Configures the interference detection threshold on the receiver.

Logs		
ITBANDPASSBANK		Provides the allowable bandpass filter configurations.
ITDETECTSTATUS	✓	Lists all of the interference detected on the paths on which automatic interference detection has been enabled.

Logs		
ITFILTTABLE		Summarizes the filter configuration for each frequency and indicates which bandpass or notch filters are enabled and configured.
ITPROGFILTBANK		Provides the allowable programmable filter configurations.
ITPSDFINAL	√	Provides the power spectral density information of the specified signal path.

3.12 Logging and retrieving data overview

Logs can be directed to any of the receiver communication ports and can be automatically generated at regular intervals or when new or changed data becomes available.

Data can be collected using NovAtel Application Suite or Manage Web. Refer to docs.novatel.com/Tools for comprehensive logging instructions.

3.12.1 Pass-through logging

The pass-through logging feature enables the GNSS receiver to redirect any ASCII or binary data that is input at a specified COM port or USB port, to any specified receiver COM or USB port. This capability, in conjunction with the SEND command, allows the receiver to perform bidirectional communications with other devices such as a modem, terminal or another receiver.

There are several pass-through logs available on OEM7 receivers for logging through serial ports. Refer to the PASSCOM logs in the [OEM7 Commands and Logs Reference Manual](#) for details.

3.12.2 Saving logs to a file

To save log data, log requests are sent to the FILE port (for example, LOG FILE BESTPOS ONTIME 1). Before the logs sent to the FILE port can be saved in a file, the file must be created (opened) on the file system using the FILECONFIG OPEN command. The log file will open when the active file media is ready and has sufficient space. The active file media is configured using the **FILEMEDIACONFIG** command.



Legacy CPT7 receivers (PN 80023560) do not support saving logs to a file.

File naming

When a file is opened, the file name is generated based on the following format:

<PSN>_<INDEX>.LOG

where:

- <PSN> is the product serial number of the enclosure
- <INDEX> is a number from 1 to 511.

The lowest number that produces an unused file name is selected. If there is no such number available, the **FILESTATUS** log will report an error.

The number is not zero-padded (i.e. the sequence is as follows: 1,2, ... ,9,10,11,12, ... ,99,100, ... , 510,511).

When a file is closed (FILECONFIG CLOSED) and the receiver has a valid time, the file is renamed based on the following format:

<PSN>_<UTC Date>_<UTC Time>.LOG

where:

- <PSN> is the product serial number of the enclosure
- <UTC_Date> is the UTC date in the format YYYY-MM-DD
- <UTC_Time> is the UTC time in the format HH-MM-SS

Example file name: NOV12001200A_2017-01-10_12-14-34.LOG

When a file is closed, but the receiver does not have a valid time, the file is left with its automatically generated name.



- The file is created before the **FILECONFIG** command returns a response.
- Only logs that are published after the log file is open are recorded.
- Only one log file can be open at a time.
- Logs requested to the FILE port are still produced even if the log file is closed, however the logs are not recorded. (This is similar to requesting logs to COM4 when there is not connection to COM4.) If a new log file is opened, recording of the previously requested logs continues with the new file.

File rotation

When collecting a large amount of log data over an extended time period, the maximum size and duration for a log file can be configured using the **FILEROTATECONFIG** command.

If the file duration is set, the log file is closed after the specified duration and a new log file is created. If the file size is set, the log file is closed after the file reaches the specified size and a new log file is created. New log files are created and closed until the file system runs out of free space or logging is stopped. If the **OVERWRITE** mode has been set, the oldest file will be deleted in order to make room for the new file so data logging can continue.

There is no data loss during the file rotation process and individual logs within the file are not spread between log files.

For more information about configuring file rotation, refer to the **FILEROTATECONFIG** command in the [OEM7 Commands and Logs Reference Manual](#).



The maximum size of a log file is 4 GB. Once this size is reached, the log file will close. Another log file will be created to continue logging.

3.12.3 Logging to internal memory

When the file media is set to internal memory (FILEMEDIACONFIG INTERNAL_FLASH), logs sent to the FILE port are saved on internal memory.



Before powering off the CPT7 or using the RESET command, use the FILECONFIG CLOSE command to close the log file.



NovAtel Application Suite or Manage Web are the recommended methods for configuring logging to internal memory. Refer to the *NovAtel UI Tools Documentation Portal* (docs.novatel.com/Tools) for information about configuring logging using the NovAtel Application Suite or Manage Web.



Legacy CPT7 receivers (PN 80023560) do not support logging to internal memory.

Logging to internal memory using the command line

To log to internal memory:

1. Set the file media to internal memory (this is the default).

```
FILEMEDIACONFIG INTERNAL_FLASH
```

2. Open a log file on internal memory.

```
FILECONFIG OPEN
```

The **LOG** LED begins to blink to show that a log file is open on internal memory.

3. Use the LOG command to start collecting logs to the file on internal memory. The logs must use the FILE port. For example:

```
LOG FILE VERSIONA
```

```
LOG FILE BESTPOSA ONTIME 1
```

Enter a LOG command for each log you want to collect.

4. Wait until the desired data has been collected.
5. Enter the following command to stop data collection and close the log file.

```
FILECONFIG CLOSE
```

The **LOG** LED changes to a solid colour to indicate that the CPT7 is no longer logging to internal memory.

3.12.4 Access CPT7 internal memory with a computer

The CPT7 has 16 GB of internal flash memory. This memory is formatted as FAT32 with a cluster size of 16 kB.



Legacy CPT7 receivers (PN 80023560) do not support this feature.

To allow a computer to access the internal memory, connect the computer to the USB port on the CPT7 and issue a FILEMEDIACONFIG DEFAULT_NO_STORAGE command. This command stops logging to internal memory and transfers control of the memory to the computer.

To return control of the internal memory back to the CPT7, issue a FILEMEDIACONFIG INTERNAL_FLASH command. The CPT7 then checks the file system on the internal memory for errors. If any errors are found, the

CPT7 attempts to correct them. This may result in files being placed in the *Lost and Found* folder in the root of the internal memory.

To reduce the likelihood of internal memory corruption or data loss, the following is recommended:

- Always use the Eject option on your computer before issuing the FILEMEDIACONFIG INTERNAL_FLASH command on the CPT7.
- If currently logging to internal memory, before powering off the CPT7, use the FILECONFIG CLOSE command to ensure there is no activity on the internal memory when the power is lost.

3.12.5 Repair errors on the CPT7 internal memory

The internal memory can become corrupt and inaccessible to the CPT7. This can happen if there is a sudden power loss when the CPT7 is transferring files from the internal memory. This can also happen if there is improper use of the internal memory when connected to a computer.



Legacy CPT7 receivers (PN 80023560) do not support this feature.

The CPT7 will attempt to repair any errors found on the internal memory. This may result in files being placed in the *Lost and Found* folder in the root of the internal memory. In the case of severe errors, the CPT7 may not be able to repair the errors and preserve user data. When this occurs, the **FILESYSTEMSTATUS** log reports an **ERROR** status for INTERNAL_FLASH and the **LOG** LED is solid red. There are two ways to recover from this condition.

Use a computer to correct the error

1. Connect a computer to the USB port on the CPT7 and issue a FILEMEDIACONFIG DEFAULT_NO_STORAGE command.
2. Use computer-based tools to repair the CPT7 internal memory.
3. Issue a FILEMEDIACONFIG INTERNAL_FLASH command to return control of the internal memory to the CPT7.



When using computer-based disk recovery utilities, ensure the internal memory remains formatted as FAT32 with a cluster size of 16 kB after the repair.

Use the CPT7 interface to reformat the internal memory



This results in a complete loss of data on the internal memory.

1. Issue a FILEMEDIACONFIG INTERNAL_FLASH command.
2. Check the **FILESYSTEMSTATUS** log.

```
log filesystemstatusa onchanged
```
3. Wait until the status of the INTERNAL_FLASH reports ERROR or MOUNTED and the LOG LED is on, but not flashing yellow (refer to *Table 6: LOG (onboard storage) LED* on page 25).
4. Use the **MEDIAFORMAT** command to reformat the internal memory.

```
MEDIAFORMAT INTERNAL_FLASH
```

5. Check the status of the internal memory in the **FILESYSTEMSTATUS** log.

When the INTERNAL_FLASH reports MOUNTED and the LOG LED is solid green, the internal memory is ready for use.

3.12.6 Logging using NovAtel Application Suite or Manage Web

The NovAtel user interface tools, *NovAtel Application Suite* and *Manage Web*, provide a graphic user interface to configure the logs output from an OEM7 receiver.

For information about configuring logging using NovAtel Application Suite, refer to docs.novatel.com/Tools/Content/Manage/ConfigurationLogging.htm.

For information about configuring logging using Manage Web, refer to docs.novatel.com/Tools/Content/WebUI_ConfigurationWindows/LoggingConfig.htm.



For information about using NovAtel Application Suite or Manage Web, refer to docs.novatel.com/Tools.

3.13 Additional features and information

The following sections contain information on additional features of the OEM7 receivers.

- *Strobes* below

3.13.1 Strobes

The CPT7 has three EVENT inputs and three EVENT outputs that provide status and synchronization signals. These signals are also referred to as strobes. For detailed information about CPT7 strobes, see *CPT7 strobe specifications* on page 199.



By default, the EVENT3_OUT signal is configured as a Pulse Per Second output.

Chapter 4 SPAN operation

Before operating your SPAN system, ensure that you have followed the installation and setup instructions in *CPT7 installation* on page 27.

You can use the NovAtel Application Suite software to configure receiver settings and to monitor data in real-time, between a rover SPAN system and base station.

SPAN system output is compatible with post-processing software from the NovAtel Waypoint Products Group. Visit our web site at novatel.com/products/waypoint-software for details.



Ensure the Control Panel Power Settings on your computer are not set to go into Hibernate or Standby modes. Data will be lost if one of these modes occurs during a logging session.

4.1 Definition of reference frames within SPAN

The reference frames that are most frequently used throughout the SPAN documentation are the following:

- *Local-level frame (ENU)* below
- *IMU body frame* on the next page
- *Vehicle frame* on page 82
- *User output frame* on page 82

4.1.1 *Local-level frame (ENU)*

The definition of the local level coordinate frame is as follows:

- E – pointing east
- N – pointing north
- U – pointing up

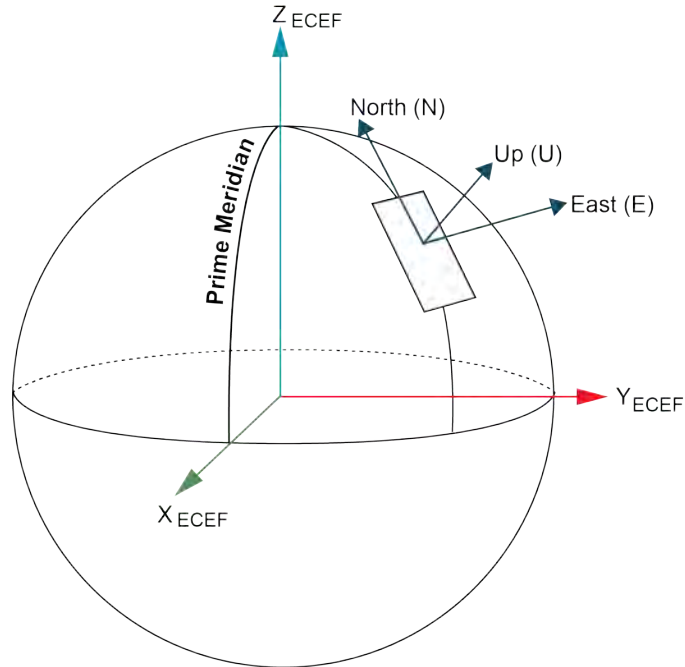
Figure 20: Local-level frame (ENU)

4.1.2 IMU body frame

The definition of the IMU Body frame is given by the physical axes of the IMU and represents how the sensors are mounted inside the IMU. The IMU Body frame axes are marked on the CPT7. Refer to *CPT7 mechanical specifications* on page 190 for illustrations of the IMU Body frame axes.



The axis marking on the CPT7 indicates the orientation of the X, Y and Z axis only. It does not indicate the centre of navigation. For the location of the centre of navigation, refer to *Figure 53: CPT7/CPT7700 centre of navigation* on page 194.

The origin of this frame is not the enclosure centre, but the centre of navigation (sensor centre).

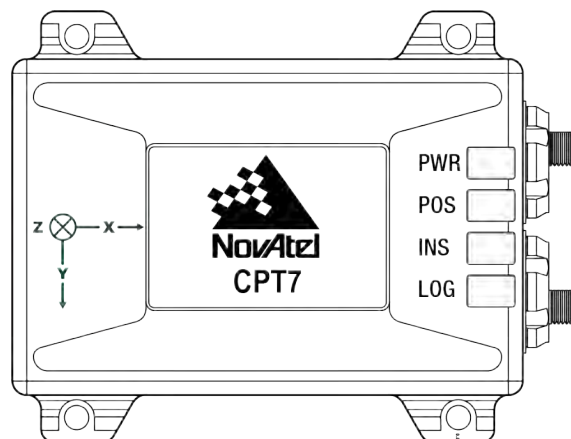
Figure 21: IMU body frame marking



The IMU body frame is a right-handed coordinate system. The axis markings indicate the positive Z axis points towards the base of the CPT7.

4.1.3 Vehicle frame

The definition of the vehicle frame is as follows:

- z-axis – points up through the roof of the vehicle perpendicular to the ground
- y-axis – points out the front of the vehicle in the direction of travel
- x-axis – completes the right-handed system (out the right-hand side of the vehicle when facing forward)

Figure 22: Vehicle frame

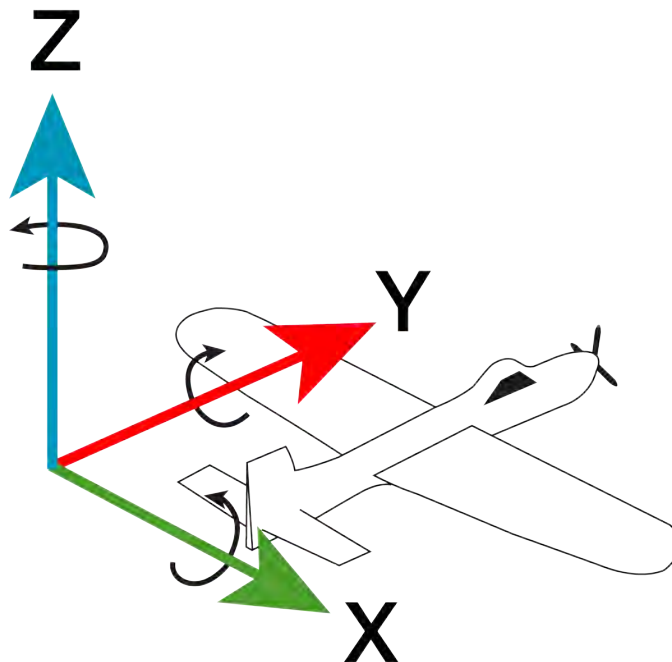

4.1.4 User output frame

The user output frame is an arbitrary frame, which can be optionally defined to transfer inertial output to a more useful position or reference frame.

By default, SPAN position and velocity output is given at the centre of navigation of the IMU. To output position and velocity at a different location, specify a user offset translation using the **SETINSTRANSLATION** command.

By default, SPAN attitude output is the rotation from the Local-Level frame to the Vehicle frame. If attitude output is desired relative to another frame, specify a user offset rotation using the **SETINSROTATION** command.

4.2 SPAN translations and rotations

A SPAN system combines GNSS and INS into a single system. In a GNSS system, the position is reported relative to the phase centre of the GNSS antenna. In an INS system, the position, velocity and attitude data is reported relative to the centre of navigation of the IMU. For a SPAN system to provide a combined GNSS+INS position, velocity and attitude, it must know where the GNSS antenna is positioned relative to the IMU.

The orientation of the IMU relative to the forward direction of the vehicle is also needed to convert the velocity and attitude changes sensed by the IMU into the actual motion of the vehicle.

If the SPAN system incorporates other devices, such as a camera connected to an Event Input, the SPAN system also needs to know the location and orientation of these additional devices relative to the IMU.

4.2.1 Translational offsets

The three dimensional distances between the IMU and other SPAN components are called translational offsets.

The translational offsets are measured in three directions, X axis, Y axis and Z axis, typically relative to the IMU Body frame. Translational offsets can also be entered relative to the Vehicle frame.



The X, Y and Z axes of the IMU Body frame are typically indicated on the IMU enclosure. The X, Y and Z axes of the IMU Body frame are also indicated on the mechanical drawings of the IMUs in the *CPT7 mechanical specifications* on page 190.

Figure 23: IMU to antenna translation offset below shows an example of the translational offsets from the IMU to a GNSS antenna. In this example, the IMU Body Frame (indicated by the small arrows) has the Y axis pointing in the direction of the vehicle motion and the z axis pointing up.

Figure 23: IMU to antenna translation offset

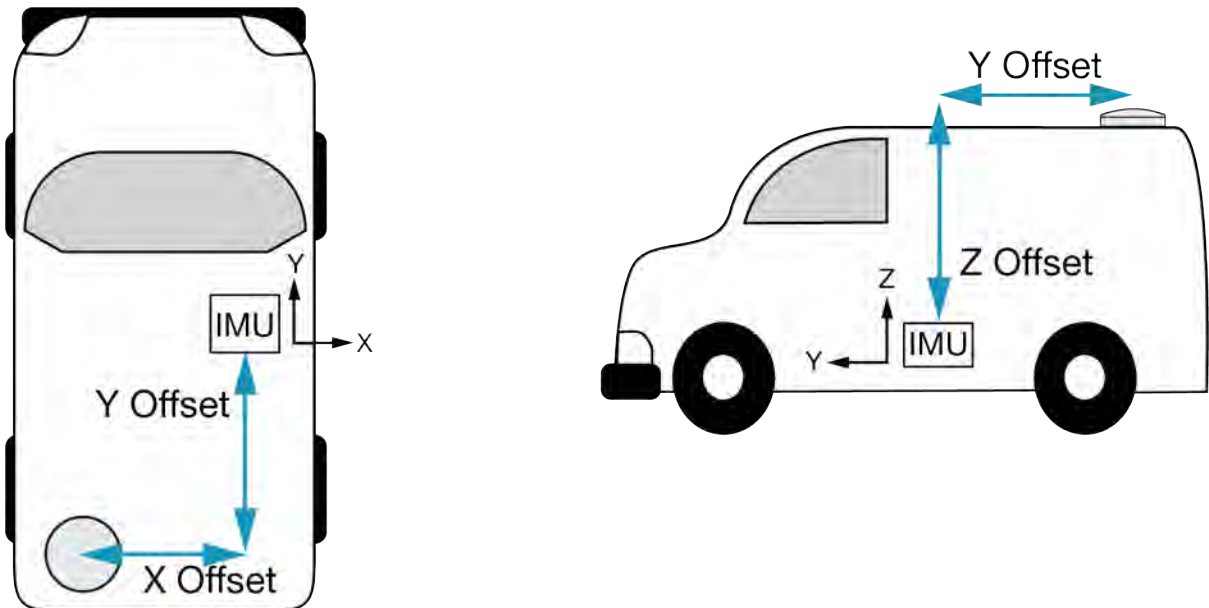

If the distances measured in this example were X Offset = 1.000 m, Y Offset = 1.500 m and Z Offset = 2.000 m, the following values would be entered, based on the IMU Body Frame:

- x = -1.000
- y = -1.500
- z = 2.000

The translational offsets are entered using the **SETINSTRANSULATION** command. For this example, the command to enter these offsets is:

```
SETINSTRANSULATION ANT1 -1 -1.5 2
```



The measurements for the translational offsets should be done as accurately as possible, preferably to within millimetres especially for RTK operation. Any error in the offsets will translate into an error in the INS position.

The translational offsets from the IMU to the GNSS antenna are required for all SPAN systems. However, some SPAN systems may have other sensors or devices integrated into the system for which the SPAN needs translational offsets. For example, a gimbal mount or a camera or LiDAR connected to an Event Input line. The offsets to these additional sensors and devices are also entered using the **SETINSTRANSLATION** command.

By default, the translational offsets are entered in the IMU Body Frame. However, in some systems the IMU Body Frame may not be known precisely. For these cases, the **SETINSTRANSLATION** command has an option that allows the offsets to be entered relative to the Vehicle Frame. In these cases, the rotation from the IMU Body Frame to the Vehicle Frame (RBV) is used to rotate offsets into the default IMU Body frame as required. To achieve the best results, this means that the RBV rotation must be known very precisely. Typically this is achieved through the SPAN RBV Calibration procedure. See *Body to vehicle frame rotation calibration routine* on page 109 or *Multi-line body to vehicle frame rotation calibration routine* on page 110 for information about this calibration procedure.

4.2.2 Rotational offsets

The differences in orientation between the IMU and other SPAN components are called rotational offsets. Rotational offsets are given as the rotation from the IMU Body Frame to the frame of interest.



The order of rotations is Z-X-Y and all rotations are right handed.

Generally, frames of reference are defined as Z up, with Y forward, and X completing the right-handed system. An example is the vehicle frame, where Z is always considered to be upwards, Y forward through the direction of travel, and X to the right.

Rotational offsets – example

Consider an IMU installed in the following way:

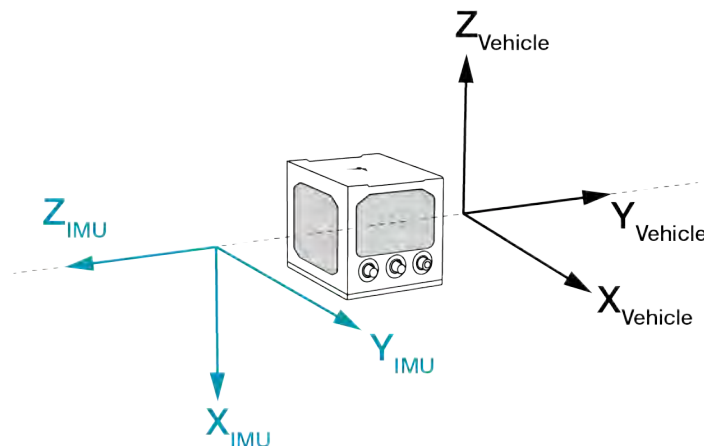

Here, the Euler Angles to rotate from the IMU Body frame to the Vehicle frame (RBV) are:

- X: -90
- Y: 0

- Z: +90

To reach this answer, keep in mind the following rules:

- The goal is to rotate the IMU Body frame to be coincident with the Vehicle frame (i.e. IMU X equals Vehicle X, IMU Y equals Vehicle Y, IMU Z equals Vehicle Z).
- You must rotate from the IMU Body frame to the Vehicle frame.
- You must rotate in the order Z, X, Y.
- Positive rotation is defined according to the right hand rule.

Z rotation:

Observe that if a positive 90 degree rotation is performed about the IMU Z axis, the rotated IMU X axis becomes collinear with the Vehicle X axis.

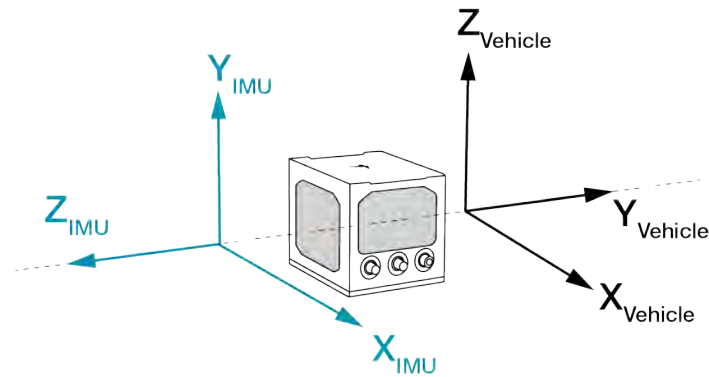

X rotation:

Observe that if a negative 90 degree rotation is performed about the new IMU X axis, the rotated IMU Y axis is now collinear with the Vehicle Y axis, and the rotated IMU Z axis is also collinear with the Vehicle Z axis.

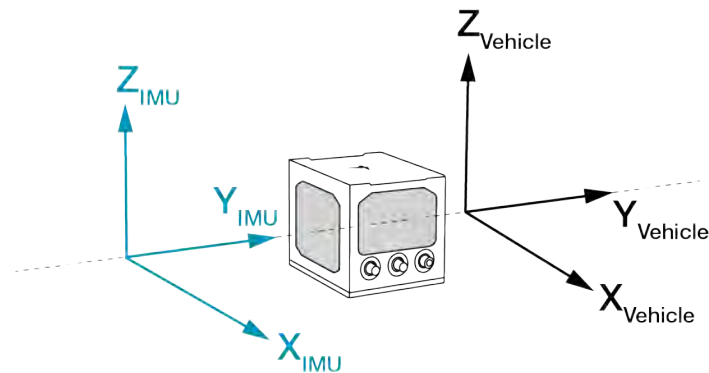

Y rotation:

Since all three sets of axes are already collinear, our frames are coincident, and no further rotation is required.



This solution is not unique. Due to the properties of Euler Angles, there are usually multiple sets of equivalent rotations.

The rotational offsets are entered using the **SETINSROTATION** command. For this example, the command to enter the rotations for the previous example is:

```
SETINSROTATION RBV -90 0 90
```

4.2.3 Output location for logs

The following table lists the output location and frames for OEM7 logs.

Table 10: Output location and frame for logs

Log	Default (position / velocity / heave) output location	Translation offset options (position / velocity / heave) SETINSTRANSATION	Rotational offset options (attitude) SETINSROTATION	Attitude reference frame
CORRIMUS CORRIMUDATA CORRIMUDATAS IMURATECORRIMUS	IMU centre of navigation	N/A	USER > RBV	IMU Body (default) → Vehicle (RBV) → Custom user (USER)
DELAYEDHEAVE	IMU centre of navigation	USER	N/A	N/A
GIMBALLEDPVA	IMU centre of navigation	USER	USER > RBV	IMU Body (default) → Vehicle (RBV) → Custom user (USER)
HEAVE	IMU centre of navigation	USER	N/A	N/A
IMURATEPVA IMURATEPVAS	IMU centre of navigation	USER	USER > RBV	IMU Body (default) → Vehicle (RBV) → Custom user (USER)
INSATT INSATTQS INSATTS INSATTX	IMU centre of navigation	N/A	USER > RBV	IMU Body (default) → Vehicle (RBV) → Custom user (USER)
INSPOS INSPOSS INSPOSX	IMU centre of navigation	USER	N/A	N/A
INSPVA INSPVACMP INSPVAS INSPVAX	IMU centre of navigation	USER	USER > RBV	IMU Body (default) → Vehicle (RBV) → Custom user (USER)
INSSPD INSSPDS	IMU centre of navigation	USER	N/A	N/A
INSVEL INSVELS INSVELX	IMU centre of navigation	USER	N/A	N/A
INSVELUSER	IMU centre of navigation	USER	USER > RBV	IMU Body → Vehicle (RBV) → Custom user (USER)
MARK1PVA TAGGEDMARK1PVA	IMU centre of navigation	MARK1	MARK1	IMU Body (default) → Custom mark (MARK1)
MARK2PVA TAGGEDMARK2PVA	IMU centre of navigation	MARK2	MARK2	IMU Body (default) → Custom mark (MARK2)

Log	Default (position / velocity / heave) output location	Translation offset options (position / velocity / heave) SETINSTRANSATION	Rotational offset options (attitude) SETINSROTATION	Attitude reference frame
MARK3PVA TAGGEDMARK3PVA	IMU centre of navigation	MARK3	MARK3	IMU Body (default) → Custom mark (MARK3)
MARK4PVA TAGGEDMARK4PVA	IMU centre of navigation	MARK4	MARK4	IMU Body (default) → Custom mark (MARK4)
PASHR	IMU centre of navigation	USER	USER > RBV	IMU Body (default) → Vehicle (RBV) → Custom user (USER)
RAWIMU RAWIMUS RAWIMUSX RAWIMUX	IMU centre of navigation	N/A	N/A	IMU Body
SYNCHEAVE	IMU centre of navigation	USER	N/A	N/A
TSS1	IMU centre of navigation	USER	USER > RBV	IMU Body (default) → Vehicle (RBV) → Custom user (USER)
BESTGNSSPOS BESTGNSSVEL	Primary Antenna L1 phase centre	N/A	N/A	N/A
BESTPOS BESTVEL	Primary Antenna L1 phase centre	N/A	N/A	N/A
PDPPOS PDPVEL	Primary Antenna L1 phase centre	N/A	N/A	N/A
PPPPOS	Primary Antenna L1 phase centre	N/A	N/A	N/A
PSRPOS PSRVEL	Primary Antenna L1 phase centre	N/A	N/A	N/A
RTKPOS RTKVEL	Primary Antenna L1 phase centre	N/A	N/A	N/A
BESTXYZ PDPXYZ PPPXYZ PSRXYZ RTKXYZ	Primary Antenna L1 phase centre	N/A	N/A	N/A



Priority of the output frame is indicated by the arrow sign (→) when multiple rotation settings have been configured.



Gimbal Locked Mount Frame backs out the INPUTGIMBALANGLE rotation to output INS in the locked frame, i.e. INS output if no gimbal angles were issued.

4.3 Vibration considerations

When designing a system that integrates SPAN, achieving excellent navigation performance requires considering the vibration environment in which the IMU will operate. IMU sensors measure motion, which may consist of real platform motion but also vibration. The INS mechanises these measurements into a full position, velocity, and attitude solution. Vibration can significantly degrade INS performance by introducing noise or errors into the IMU sensor measurements. It can be especially impactful when unfavourable INS performance conditions are present, like poor GNSS reception, low dynamics and non-optimal configurations. Managing vibration is very important to achieve optimal SPAN system performance.

4.3.1 Sources of error

Vibration affects an INS in several different ways that should be considered.

Noise and errors in the raw IMU measurements can arise from:

- Aliasing – signals at frequencies higher than the sampling rate incorrectly appear at low frequencies or as a bias.
- Clipping – the measurement range of the sensor is exceeded, inducing error in measurements and a bias in the smoothed measurements.
- Vibration Rectification Error (VRE) – changes in vibration induce a bias in the measurements that cannot be filtered out.
- Amplification of standard IMU errors – as measurements approach the range limits of the sensor, even when oscillating around a mean near zero.

INS solution quality experienced at the output from a SPAN system is impacted by:

- IMU lever arm rigidity and accuracy – vibration can cause more flexing and make rigid body assumptions less applicable.
- USER lever arm configuration – oscillation of the INS solution attitude due to vibration amplifies noise and apparent error when the solution is translated to the USER offset.
- SPAN logging configuration (i.e. solution output sampling rate) – insufficient logging rates can cause aliasing in the output solution if oscillation frequency in the INS solution due to vibration exceeds half the output logging rate.

4.3.2 Mitigation methods

Vibration is best mitigated in the mechanical domain prior to IMU exposure. Key methods to mitigate in the mechanical domain include:

- Selecting the IMU mounting location to achieve subsystem separation, structural rigidity considerations, and optimal locations for system dynamics and lever arms.
- Appropriate IMU mounting methods that prioritize rigidity and dimensional stability.
- Carefully designed custom IMU mounts that incorporate vibration isolation features.
- Characterization and minimization of unwanted resonance in the system in the context of system vibration sources.

When the IMU will be exposed to vibration, robust IMU specification design is important to ensure the INS performs adequately in the overall system. For example, the IMU measurement range to avoid signal clipping when exposed to the combination of vibration, maximum system dynamics and gravity. The needs of individual applications will vary and may benefit from an iterative system design approach to manage tradeoffs.

The interface design between the INS and overall system must support the logging configuration and rates needed to minimize solution signal distortion and support any monitoring, post-processing or control loop

requirements. Using an anti-aliasing filter at the solution output may be necessary. Contact *Customer Support* on page 16 for additional information.

4.3.3 Additional notes

The unique characteristics of each SPAN system integration requires a tailored vibration management approach within the context of the application. A general solution is not appropriate given the range of vibration environments and system requirements.

An important aspect of the vibration management approach is that changing vibration conditions are most impactful to INS performance.

With careful consideration of vibration early in the system design cycle, optimal SPAN performance can be achieved.



For in-depth information about vibration, please review NovAtel Application Note [APN-112: Inertial Navigation System and Vibration](#).

4.4 Software configuration

On a SPAN system, both the GNSS receiver and the IMU must be configured.

4.4.1 GNSS configuration

The GNSS configuration can be set up for different accuracy levels such as single point, SBAS, DGNSS, PPP and RTK. Refer to *OEM7 receiver operation* on page 44 for information about configuring the GNSS settings.

With no additional configuration, the system operates in single point mode.





4.4.2 INS Profiles

INS Profiles provide two major functions; simplified configuration and enhanced performance. Each INS Profile sets specific filter behaviour to enhance system performance in particular environments.

The INS profile settings are enabled by the receiver model. A receiver model with an INS Mode of **S**, **P**, **R** or **K** is required to enable INS Profiles. The INS profile adds enhanced behaviour such as Dead Reckoning for land and Heave for marine and allows for simple configuration rather than sending many discreet commands.

Table 11: OEM7 INS Profiles

Profile	Description	Enhanced Profile settings
DEFAULT	The default SPAN profile. This profile has legacy SPAN default settings.	N/A

Profile	Description	Enhanced Profile settings
LAND	INS Profile for fixed axle land vehicles. Enables robust kinematic alignment routines and configures the update profile.	<p>Enables intelligent vehicle dynamics modelling for land vehicles (Dead Reckoning).</p> <p>Enables course over ground attitude updates.</p> <p>Enables direction detection on kinematic alignment routine.</p> <div style="border: 1px solid #ccc; padding: 5px; margin-top: 10px;">  Sets alignment velocity to 0.5 m/s. </div>
MARINE	INS profile for marine vessels. Disables static behaviour and configures the marine solution to be more robust.	<p>Disables Zero Velocity Updates (ZUPT).</p> <p>Disables turn-on bias static estimation.</p> <div style="border: 1px solid #ccc; padding: 5px; margin-top: 10px;">  Sets alignment velocity to 3.0 m/s. </div>
FIXEDWING	INS profile for fixed wing aircraft	<div style="border: 1px solid #ccc; padding: 5px; margin-top: 10px;">  Sets alignment velocity to 3.0 m/s. </div>
FOOT	INS profile for walking or backpack applications	<div style="border: 1px solid #ccc; padding: 5px; margin-top: 10px;">  Sets alignment velocity to 0.5 m/s. </div>
VTOL	INS profile for Vertical Take Off and Landing aircraft (helicopter, quadcopter, etc.)	None
RAIL	INS profile for railway applications	<p>Enables intelligent vehicle dynamics modelling for rail vehicles (Dead Reckoning).</p> <p>Enables course over ground attitude updates.</p> <p>Enables direction detection on kinematic alignment routine.</p> <div style="border: 1px solid #ccc; padding: 5px; margin-top: 10px;">  Sets alignment velocity to 5.0 m/s. </div>

Profile	Description	Enhanced Profile settings
AGRICULTURE	INS profile for agriculture applications	<p>Enables intelligent vehicle dynamics modelling for agricultural vehicles (Dead Reckoning).</p> <p>Enables course over ground attitude updates.</p> <p>Enables direction detection on kinematic alignment routine.</p> <div style="border: 1px solid #0070C0; padding: 5px; margin-top: 10px;">  Sets alignment velocity to 0.5 m/s. </div>

Use

To use an INS Profile, send the **SETINSPROFILE** command at startup (or save to NVM) to activate the mode. For example:

```
SETINSPROFILE LAND
```

The type of profile activated, basic or enhanced, is determined by the SPAN model.



The currently selected profile option is available in the **INSCONFIG** log.

RBV calibration

For the profiles to provide the greatest benefit, the rotation offset of the IMU body to the vehicle frame (RBV) should be known as accurately as possible. Since constraints happen at the vehicle level, any error in the offset will translate into worse performance. These parameters are estimated in the background when the system is fully converged, however it is always better to have this measured as precisely as possible before mission critical data is collected.

The INSCALIBRATE RBV functionality can be used to estimate and save these offsets to NVM in a controlled manner.

4.4.3 Configure the CPT7 IMU data rate

By default, the CPT7 and CPT7700 are configured for a 100 Hz raw IMU data rate.

To change the IMU data rate to 400Hz:

1. Ensure the CPT7 has a Model with the SPAN IMU Grade option 2 or 3.
If the CPT7 does not have IMU Grade option 2 or 3, contact NovAtel Support or Sales for information about upgrading.
2. Issue the following command.(and saveconfig if desired):

```
CONNECTIMU COM3 HG4930_AN04_400HZ
```
3. Optionally, use the following command to save the new configuration in Non-Volatile Memory (NVM).

```
SAVECONFIG
```



On Legacy CPT7 receivers (PN 80023560) only the 100 Hz IMU data rate is available.

4.4.4 SPAN configuration for CPT7

- *Minimum recommended configuration* below
- *Configure SPAN manually* below
- *SPAN configuration with NovAtel Application Suite* on page 94
- *SPAN configuration with NovAtel Manage Web* on page 94

Minimum recommended configuration

When configuring your CPT7 system for first time use, the following is the minimum amount of information required to ensure proper operation of a SPAN system.

Required information	Required command
IMU to primary antenna lever arm	SETINSTRANSFORMATION ANT1
IMU to secondary antenna lever arm (<i>CPT7 only</i>)	SETINSTRANSFORMATION ANT2
IMU to vehicle frame rotation	SETINSROTATION RBV



For optimal SPAN operation, the IMU to antenna lever arms and the IMU to vehicle frame rotation should be measured or calibrated to the best accuracy possible. Even small errors in the lever arm or RBV can lead to significant degradation of the overall INS performance.

While this is the minimum amount of information required, additional information is typically needed for SPAN systems. The following commands are commonly used to configure SPAN systems.

Common user settings	Appropriate command	Notes
IMU to output position offset	SETINSTRANSFORMATION USER	Default output position is at the IMU centre
IMU to output frame rotation	SETINSROTATION USER	Default output frame is the vehicle frame as defined by SETINSROTATION RBV input
Vehicle type	SETINSPROFILE	
Minimum alignment velocity	SETALIGNMENTVEL	

Configure SPAN manually

Follow these steps to enable INS as part of the CPT7 system using software commands:



A GNSS antenna with a clear view of the sky must be connected and tracking satellites for operation.

1. Issue the **SETINSTRANSLATION** command, using the **ANT1** parameter, to enter the distance from the CPT7 to the primary GNSS antenna.

Issue the **SETINSTRANSLATION** command, using the **ANT2** parameter, to enter the distance from the CPT7 to the secondary GNSS antenna (*CPT7 only*).

See the **SETINSTRANSLATION** command in the [OEM7 Commands and Logs Reference Manual](#) for more information.

The offset between the antenna phase centre and the IMU axis must remain constant and be known accurately (m). The X, Y and Z directions are clearly marked on the CPT7 enclosure. The **SETINSTRANSLATION** parameters are (where the standard deviation fields are optional and the distances are measured from the CPT7 to the antenna):

```
ANT1 x_offset y_offset z_offset [x_stdev] [y_stdev] [z_stdev]
ANT2 x_offset y_offset z_offset [x_stdev] [y_stdev] [z_stdev]
```

For example, in the following scenario:

- the CPT7 is mounted on the floor in the orientation described in *Mount the CPT7* on page 34 (positive Z down, positive X forward)
- the primary and secondary GNSS antennas are mounted on the roof of the vehicle
- the distance measured from the CPT7 to the primary GNSS antenna is 2 metres up (Z axis), 0.5 metres right (Y axis) and 1 metre forward (X axis)
the distance measured from the CPT7 to the secondary GNSS antenna is 2 metres up (Z axis), 0.5 metres left (Y axis) and 1 metre forward (X axis)

the **SETINSTRANSLATION** commands would be:

```
SETINSTRANSLATION ANT1 1.0 -0.5 -2.0
SETINSTRANSLATION ANT2 1.0 0.5 -2.0
```

Figure 24: CPT7 to antenna offset

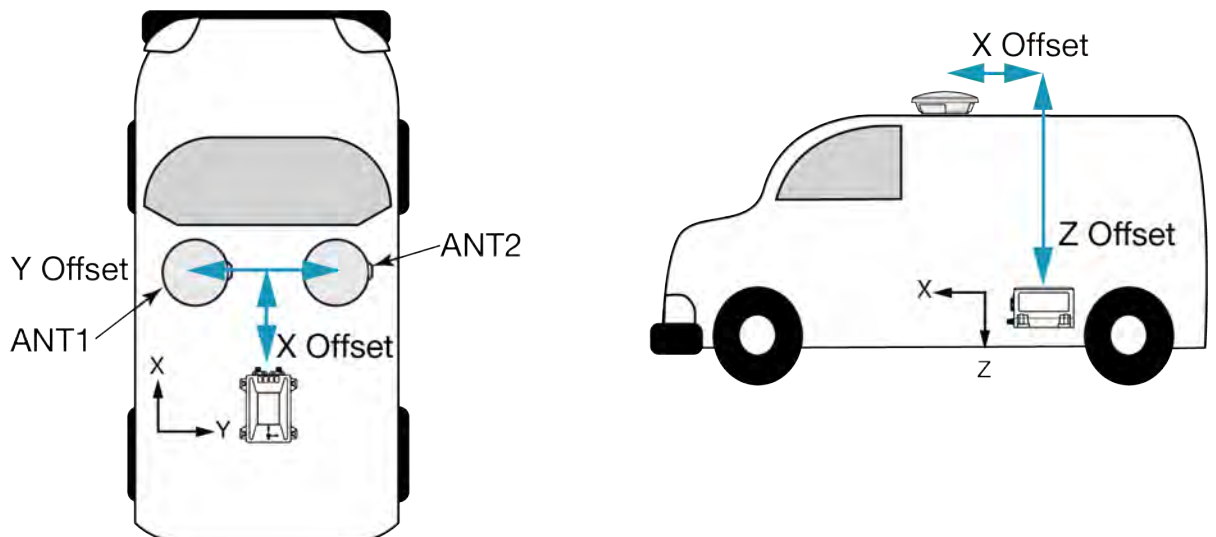



The axis marking on the CPT7 indicates the orientation of the X, Y and Z axis only. It does not indicate the centre of navigation. For the location of the centre of navigation, refer to *Figure 53: CPT7/CPT7700 centre of navigation* on page 194.

A typical RTK GNSS solution is accurate to a few centimetres. For the integrated GNSS+INS system to have this level of accuracy, the offset must be measured to within a centimetre. Any offset error between the two systems shows up directly in the output position. For example, a 10 cm error in recording this offset will result in at least a 10 cm error in the output.

- Issue the **SETINSROTATION** command, using the **RBV** parameter, to enter the Euler Angle rotation from the IMU Body frame to the Vehicle frame. See the **SETINSROTATION** command in the [OEM7 Commands and Logs Reference Manual](#) for more information.

Accurate knowledge of the rotational offset between the IMU Body frame and the Vehicle frame (the RBV rotation) is critical to correctly computing an attitude solution, and is required before a Kinematic alignment is possible.

The SETINSROTATION parameters are (where the standard deviation fields are optional):

```
RBV x_rotation y_rotation z_rotation [x_stddev] [y_stddev] [z_stddev]
```



The order of rotations is Z-X-Y. All rotations are right handed.

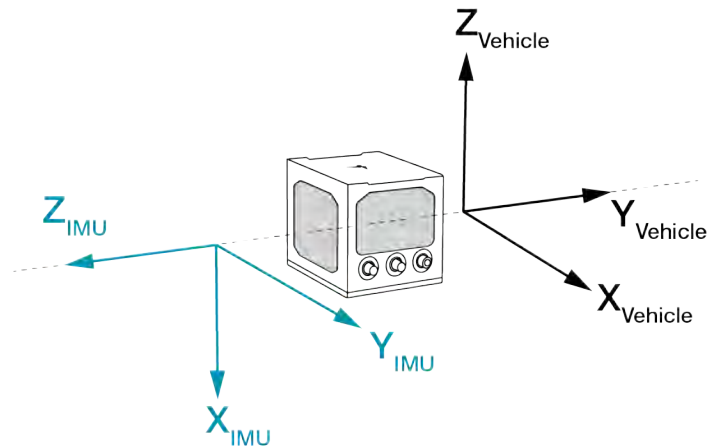

For an example of how to solve for the IMU Body to Vehicle frame rotation refer to *Rotational offsets* on page 84.

If the rotation between the IMU Body frame and the Vehicle frame is not precisely known, enter an approximate rotation (to the nearest 45 degrees). The precise offset can be estimated by carrying out the *Body to vehicle frame rotation calibration routine* on page 109.

SPAN configuration with NovAtel Application Suite

NovAtel Application Suite provides a graphical user interface to help configure a SPAN system. For information about configuring SPAN using NovAtel Application Suite, refer to docs.novatel.com/Tools/Content/ToolsSuite/Overview.htm.

SPAN configuration with NovAtel Manage Web

The SPAN parameters can be configured using the NovAtel Manage Web User Interface. For information about using Manage Web, refer to docs.novatel.com/Tools/Content/Manage_Web/Overview.htm.

4.4.5 Importance of lever arms

For the SPAN system to provide optimum performance, the lever arm of the IMU to the antenna should be measured as accurately as possible. The accuracy of the lever arm measurement impacts the accuracy of the INS solution PVA output. The type of the GNSS positioning used is also a factor. For example, an application using single point GNSS requires less accurate lever arm measurements compared to an application using RTK requiring centimetre level accuracy.

In general, the lever arm measurements should be measured to a better accuracy than the desired INS PVA output accuracy. The accuracy of the GNSS position is also a factor in the overall accuracy. For example, if the desired INS accuracy level is to be within 3 cm, and RTK positioning with an accuracy of 2 cm is used, then the lever arms must be measured to an accuracy level better than 1 cm. This results in an overall accuracy level of 3 cm (2 cm for RTK and 1 cm for INS).

The location of the IMU with respect to the primary antenna is also important. The IMU should be placed as close as possible to the primary antenna for the best performance. This is not always practical so longer lever arm lengths are okay. However as the lever arm distance increases, the accuracy of the lever arm measurement becomes more important.

Finally, when entering the lever arm into the SPAN system via the **SETINSTRANSLATION** command, the standard deviations of the lever arm measurement are also entered. This is an estimate of how accurate the lever arms were measured. These standard deviations should be entered with correct accuracies for their measurements. An incorrect lever arm standard deviation, either pessimistic or optimistic, might have negative impacts on SPAN performance.

Measuring the lever arm

One method of measuring the lever arm is to use a total station and perform a survey between the IMU and the antenna. This method is ideal when the IMU and antenna are in a permanent location in the vehicle and will not be removed for an extended period. A survey will normally provide very accurate lever arm measurements so this is the best option when using RTK.

Figure 25: Antenna lever arm – total station

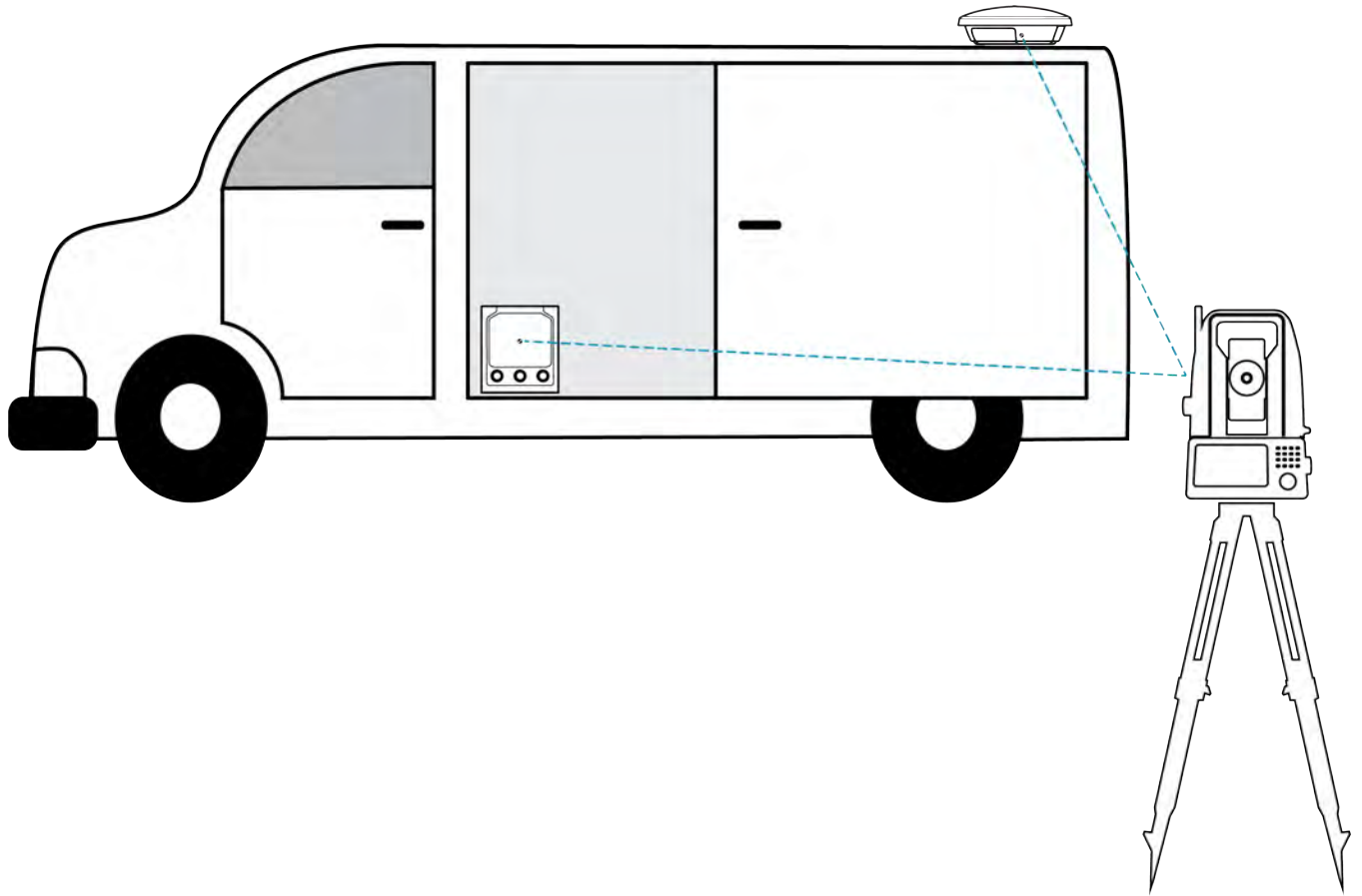

Performing a survey with a total station can be time consuming and expensive, so a simpler method is to use a measuring tape and a plumb bob. The vehicle should be level when measuring is done. The first measurement should be the Z axis starting at the antenna to the surface where the IMU is mounted. This measurement should be done with both the plumb bob and the measuring tape. Once this measurement is completed, the X and Y axis measurements can be done with only the measuring tape.

Figure 26: Antenna lever arm – tape measure

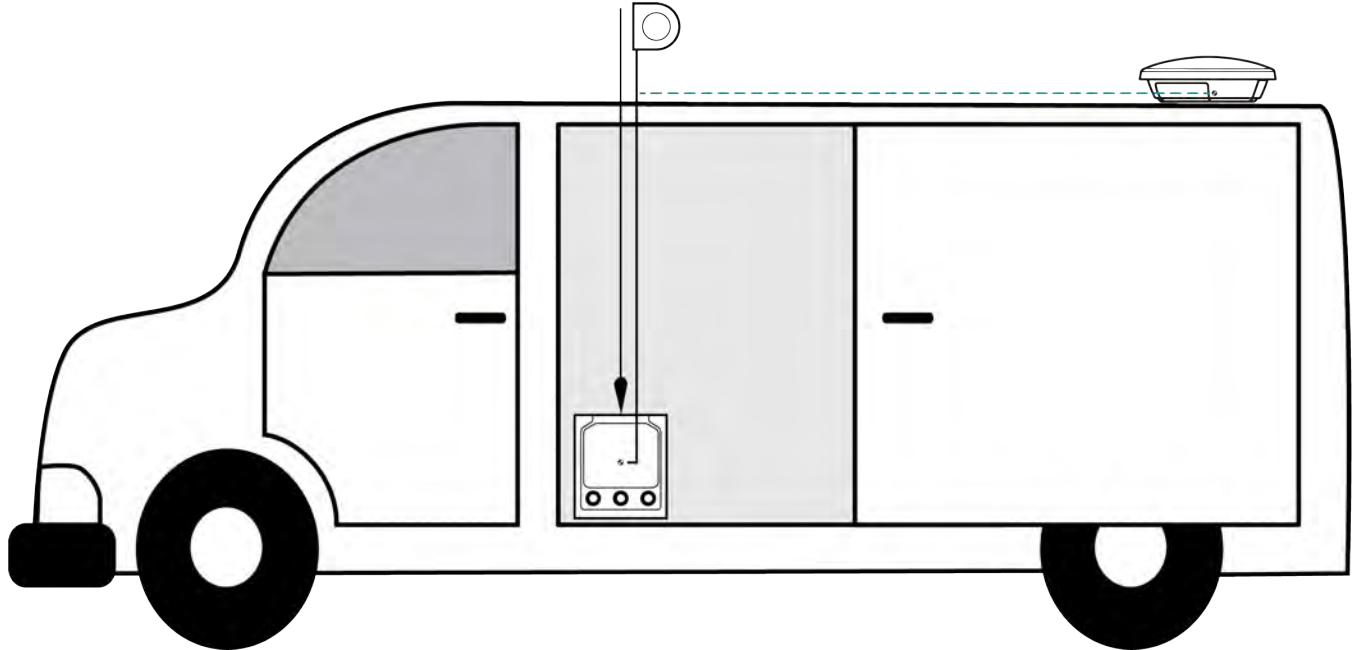

4.4.6 Importance of RBV calibration

For the SPAN system to provide the best performance, the rotation offset of the IMU body to the Vehicle frame (RBV) should be known as accurately as possible. Since constraints happen at the vehicle level, any error in the offset will translate into worse performance.

After the SPAN system has been installed and the appropriate translations and rotations have been applied (see *SPAN translations and rotations* on page 82), the IMU Body frame is aligned with the Vehicle frame. However, aspects of the mounting platform and vehicle design, such as roof camber or tilt, and slight misalignments in installation can cause the IMU Body frame to be slightly out of alignment with the Vehicle frame. The misalignment of the IMU Body frame from the Vehicle frame will add a bias to the SPAN solution.

The following diagrams show examples of a CPT7 installed in a vehicle with misalignment issues.

Figure 27: Rear view of CPT7 – mounting plate is not flat

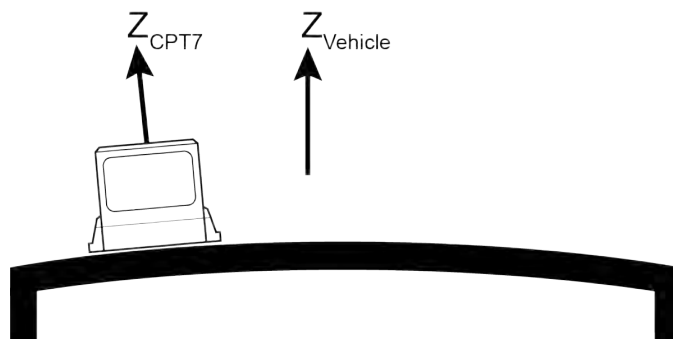
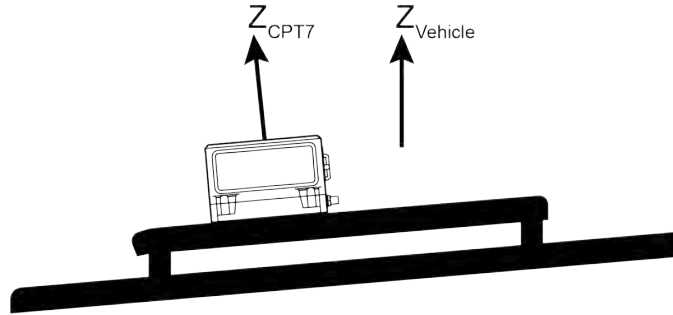
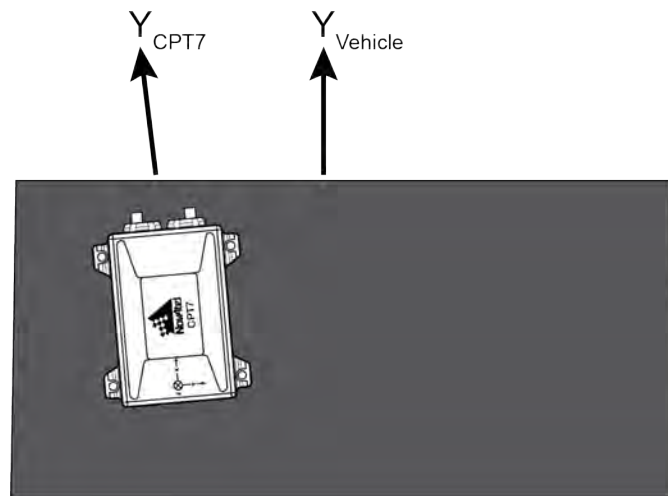

Figure 28: Side view of CPT7 – vehicle is not level**Figure 29: Top view of CPT7 – CPT7 misalignment**

The misalignments shown in the previous figures have been exaggerated for illustration purposes.

In a typical SPAN system installation, the slight misalignments shown in the examples above are hard to detect and difficult to measure. For this reason, it is recommended that a Body to Vehicle Frame rotation calibration routine be used so the SPAN system can determine and compensate for these angles. Refer to *Body to vehicle frame rotation calibration routine* on page 109 or *Multi-line body to vehicle frame rotation calibration routine* on page 110 for more information.

These parameters are estimated in the background when the system is fully converged, however it is always better to have this measured as precisely as possible before mission critical data is collected.



Since slight variations in alignment can be introduced when the CPT7 is remounted, a Body to Vehicle Frame calibration should be performed each time the device is remounted.



An accurate RBV is especially important if the position is being transferred to a user offset.

4.4.7 Importance of antenna location for ALIGN

To achieve the best SPAN performance when using dual antenna (ALIGN):

- the two GNSS antennas should be mounted on the vehicle securely in a stable location
- the two GNSS antennas should be mounted as far apart as possible
- the two GNSS antennas should be mounted away from other vehicle obstructions resulting in a clear view of the sky
- the primary GNSS antenna should be mounted as close as possible to the IMU

The primary and secondary GNSS antenna can be mounted anywhere on the vehicle with a fixed distance (baseline) between them. The baseline between the two antennas does not need to be aligned with the vehicle axes or with the axes of the IMU.

The heading accuracy is dependent on the antenna baseline length. For best performance, mount the antennas as far apart as possible. A separation of 1 metre is the minimum recommended distance. At a baseline length of 1 metre, the ALIGN accuracy is 0.20°. If the baseline length were 0.5 metre, the ALIGN accuracy would be 0.40°. A 2 metre baseline results in an ALIGN accuracy of 0.08°.

Finally, the primary antenna should be mounted as close as possible to the IMU while still maintaining a maximum antenna baseline length. This may lead to some compromise being made for the primary antenna location. Preference should be put on keeping the primary antenna closer to the IMU even it results in a shorter baseline between the two GNSS antennas.

As with the primary antenna lever arm, it is also important to have the best possible accuracy on the IMU to the secondary antenna lever arm (refer to the *Importance of lever arms* on page 95). However, as measuring lever arms can be difficult, an alternative is to calibrate the IMU Body frame to ALIGN frame rotation using the **INSCALIBRATE** command or to measure that rotation directly and enter it using the **SETINSROTATION** command.

4.5 Real-time operation

SPAN operates through the OEM7 command and log interface. Refer to the [OEM7 Commands and Logs Reference Manual](#) log and command details.

Real-time operation notes:

- By default, raw IMU data will begin to output as soon as the IMU is connected. However, an initial position is required to begin the INS alignment process. This position is typically set by GNSS. The GNSS position will not be used until the FINESTEERING time status is reached. This requires a GNSS antenna connected with a clear view of the sky. See *System start-up and alignment techniques* on the next page for more details.
- The inertial solution is computed separately from the GNSS solution. The GNSS solution is available from the SPAN system through the GNSS-specific logs, even without SPAN running. The integrated GNSS+INS solution is available through special INS logs documented in SPAN Logs in the [OEM7 Commands and Logs Reference Manual](#).
- The IMU raw data is available at the maximum rate of output of the IMU. Because of this high data rate, a shorter header format was created. These shorter header logs are defined with an S (RAWIMUSXB rather than RAWIMUXB). We recommend you use these logs instead of the standard header logs to save throughput on the COM port.

Status of the inertial solution can be monitored using the inertial status field in the INS logs.

Table 12: Inertial solution status

Binary	ASCII	Description
0	INS_INACTIVE	IMU logs are present, but the alignment routine has not started; INS is inactive.
1	INS_ALIGNING	INS is in alignment mode.
2	INS_HIGH_VARIANCE	The INS solution uncertainty contains outliers and the solution may be outside specifications. ¹ The solution is still valid but you should monitor the solution uncertainty in the INSSTDEV log. It may be encountered during times when GNSS is absent or poor.
3	INS_SOLUTION_GOOD	The INS filter is in navigation mode and the INS solution is good.
6	INS_SOLUTION_FREE	The INS Filter is in navigation mode and the GNSS solution is suspected to be in error. The inertial filter will report this status when there are no available updates (GNSS or other) being accepted and used.
7	INS_ALIGNMENT_COMPLETE	The INS filter is in navigation mode, but not enough vehicle dynamics have been experienced for the system to be within specifications.
8	DETERMINING_ORIENTATION	INS is determining the IMU axis aligned with gravity.
9	WAITING_INITIALPOS	The INS filter has determined the IMU orientation and is awaiting an initial position estimate to begin the alignment process.
10	WAITING_AZIMUTH	The INS filter has orientation, initial biases, initial position and valid roll/pitch estimated. Will not proceed until initial azimuth is entered.
11	INITIALIZING_BIASES	The INS filter is estimating initial biases during the first 10 seconds of stationary data.
12	MOTION_DETECT	The INS filter has not completely aligned, but has detected motion.
14	WAITING_ALIGNMENTORIENTATION	The INS filter is waiting to start alignment until the current Vehicle Frame roll and pitch estimates are within the configured threshold of the expected orientation (set by the SETALIGNMENTORIENTATION command). Note: This requires an accurate RBV rotation to be configured, see the SETINSROTATION command.

4.5.1 System start-up and alignment techniques

The SPAN system requires an initial position, velocity and attitude estimate to start the navigation filter. This is called system alignment. On start-up, the system has no position, velocity or attitude information. When the system is first powered up, the following sequence of events happens:

1. The first satellites are tracked and coarse time is solved.
2. Enough satellites are tracked to compute a position.

1. The solution uncertainty threshold levels can be adjusted using the **INSTHRESHOLDS** command.

3. Receiver “fine time” is solved, meaning the time on board the receiver is accurate enough to begin timing IMU measurements.
4. The INS Status field changes from INS_INACTIVE through DETERMINING_ORIENTATION and WAITING_INITIALPOS.
5. Once a GNSS position is available, an initial IMU bias estimate is conducted. During this period, the INS Status field reports INITIALIZING_BIASES.
6. After the bias estimate is complete, the coarse alignment routine starts. Bias estimates will be refined and a static coarse alignment completed, if IMU quality allows. During this period the INS Status field reports INS_ALIGNING.
7. If static coarse alignment is not possible or is locked out by command, the system will require an external azimuth input, either from vehicle motion, dual antenna input or command input. While in this state the INS Status field reports WAITING_AZIMUTH.

If vehicle movement is detected, any ongoing static coarse alignment will be reset, and the INS Status field will report MOTION_DETECT.
8. After an alignment is completed, the INS Status field changes to INS_ALIGNMENT_COMPLETE. The system transitions to *Navigation mode* on page 106.
9. The solution is refined using updates from GNSS. Once the system starts estimating the IMU errors after some vehicle movement, the INS Status field will change to INS_SOLUTION_GOOD indicating INS solution has achieved a basic level of convergence. Note that it is advised to continue converging dynamics until the convergence flag is set to 1 in the Extended Solution Status word . This indicates that the INS filter has successfully converged to within performance specifications.

SPAN alignment methods

The following sections describe the different alignment routines available. By default, the first available method to align is used. Options for configuring a specific alignment methods are outlined below.

Static coarse alignment

The static coarse alignment is the default alignment routine for SPAN. The alignment starts automatically when a GNSS solution is available, the receiver has computed fine time, the IMU is connected and configured, and initial bias estimates have been completed. During the static coarse alignment, accelerometer and gyro measurements are averaged over a period of time to measure Earth rotation and gravity. From these averaged measurements, initial estimates of roll, pitch and heading are computed. Because the static coarse alignment uses averaged sensor output, the vehicle must remain stationary for the duration of the alignment, which is approximately 45 seconds. The attitude estimates solved by the alignment are larger than the system specified attitude accuracy and vary upon the characteristics of the sensor and the geographic latitude of the system. Attitude accuracy converges with motion after the coarse alignment is complete (see *Navigation mode* on page 106).



All **Grade 1** IMUs, as well as the HG4930 400Hz variant, and products that use these IMUs, cannot perform static coarse alignments, as these IMUs cannot accurately measure Earth rotation (see IMU Grade on the OEM7 Documentation Portal (docs.novatel.com/OEM7)). For these IMUs, the default alignment routine is kinematic alignment. Refer to *Kinematic alignment* on the next page. If a stationary alignment is required, refer to options for *Dual antenna alignment* on the next page, *NVM seeded alignment* on the next page, or *Manual alignment* on the next page.

Static Coarse alignments may be degraded due to environment, vibration or IMU age effects. Any error in initial alignment can cause performance issues.

Kinematic alignment

An alternate form of aligning the SPAN system is a kinematic alignment. A kinematic alignment can be used for any SPAN system and is the best alignment alternative for lower performance sensors (**Grade 1** IMUs, as well as the HG4930 400Hz variant, and products that use these IMUs). The kinematic or moving alignment is performed by estimating the heading from the GNSS velocity vector and injecting it into the SPAN filter as the initial system heading.

For the kinematic alignment routine to work optimally, the course-over-ground azimuth must not include any bias from the defined Vehicle Frame. (For example, a plane being blown in the wind has a large 'crab angle' and the course-over-ground trajectory will not match the direction the IMU is pointing.)

The rotation from the IMU Body frame to the Vehicle frame (RBV) must be set to enable kinematic alignment. In order to simplify this configuration it is strongly suggested that you mount the IMU in parallel to the vehicle frame.



When using the default RBV configuration, the X-axis of the CPT7 should point in the direction of travel.

The kinematic alignment begins when the receiver has a good GNSS position, fine time is solved, the Body to Vehicle frame rotation is known and a GNSS velocity of at least 5 m/s (~ 18 km/h) is observed. For optimal performance, it is recommended to keep the vehicle fairly level during kinematic alignment.



5 m/s (~ 18 km/h) is the default alignment velocity. If a different alignment velocity is required, it can be changed using the **SETALIGNMENTVEL** command. Refer to the [OEM7 Commands and Logs Reference Manual](#) for more information.

While it is possible to lower the minimum speed required for kinematic alignment to take place, the higher the value, the more closely the course-over-ground estimate will match the vehicle heading.

The accuracy of the initial attitude of the system following the kinematic alignment varies and depends on the dynamics of the vehicle. The attitude accuracy will converge to within specifications once some motion is observed by the system. This transition can be observed by monitoring the INS Status field in the INS logs.

Dual antenna alignment

SPAN can also use heading information available from a NovAtel Dual Antenna ALIGN solution to rapidly perform an alignment. Refer to *CPT7 with dual antenna* on page 128 for details.

NVM seeded alignment

SPAN can use the alignment information from a previous power up to quickly perform an alignment. For information about enabling and using an NVM Seeded Alignment, refer to *INS Seed / Fast INS initialization* on page 104.

Manual alignment

If the initial azimuth of the system is known, it can be entered manually using the **SETINITAZIMUTH** command. Refer to the [OEM7 Commands and Logs Reference Manual](#) for more information about this

command.

A manual alignment should be used only if the azimuth is accurately known.

Configuring SPAN alignment method

The SPAN-enabled receiver can be configured for different alignment routines depending on the motion conditions experienced during the alignment period. For example, in marine applications, the dynamics required for either a static coarse or kinematic alignment cannot be guaranteed, so a different alignment routine will be required. This is achieved with the **ALIGNMENTMODE** command.

NVM Seeded alignment and Manual alignments are valid for all alignment modes and will supersede all other options if valid and available.

Automatic alignment mode (default)

The automatic alignment mode is the default setting for a SPAN-enabled receiver. This mode is designed to allow alignment of the system as quickly as possible, using any of the alignment methods (Static Coarse, Kinematic, NVM Seeded, Dual Antenna or Manual), regardless of its relative quality. No additional configuration is required to use this alignment routine. If a specific alignment technique is desired, it must be selected manually to guarantee that alignment method.

Unaided alignment mode

The unaided alignment mode sets the SPAN system to use only single antenna and superseding alignment options (Static Coarse, Kinematic, NVM Seeded or Manual alignment).

To use this alignment mode, the **ALIGNMENTMODE** command must be sent to the receiver.

```
ALIGNMENTMODE UNAIDED
```

Aided transfer alignment mode

The aided transfer alignment mode sets the SPAN system to use only dual antenna and superseding alignment options (Dual Antenna, NVM Seeded or Manual alignment).

This alignment routine is the preferred dual antenna alignment method.

If the vehicle is not stationary during the alignment, such as may be the case on a ship, use the Aided Transfer Alignment routine. This alignment method uses the ALIGN baseline solution to perform an instantaneous alignment of the vehicle azimuth.

The alignment happens instantaneously after the receiver establishes communication with the IMU and computes a verified, fixed integer, ALIGN solution.

To guarantee the use of this alignment mode, the **ALIGNMENTMODE** command must be sent to the receiver:

```
ALIGNMENTMODE AIDED_TRANSFER
```

Static coarse alignment mode

The static coarse alignment mode sets the SPAN system to use only static coarse and superseding alignment options (Static Coarse, NVM Seeded or Manual alignment).

To guarantee the use of this alignment mode, the **ALIGNMENTMODE** command be sent to the receiver:

```
ALIGNMENTMODE STATIC
```

Kinematic alignment mode

The kinematic alignment mode sets the SPAN system to use only kinematic and superseding alignment options (Kinematic, NVM Seeded or Manual alignment).

To guarantee the use of this alignment mode, the **ALIGNMENTMODE** command must be sent to the receiver:

```
ALIGNMENTMODE KINEMATIC
```

4.5.2 INS Seed / Fast INS initialization

The INS Seed functionality is an alignment method whereby INS alignment information from a previous power up can be injected into the system at start up to achieve an INS alignment more quickly. This is especially useful for systems that previously required a kinematic alignment.

When INS Seed is enabled, alignment data is automatically saved when appropriate, with no specific action required from the user. During subsequent power ups, the saved solution is compared to the current azimuth of the system, and if valid, the saved solution is used to immediately align the inertial filter, making it ready for use.

Error model information is also saved with the seed data. Even if full alignment cannot be achieved, this information can still be used to aid filter convergence, although another method of alignment will be required.

This feature is enabled via the **INSSEED** command. This command setting must be saved to NVM via the **SAVECONFIG** command to be used upon next system boot-up.

Criteria

For the INS seed functionality to be enabled, the **INSSEED ENABLE** command must be sent.

Saving

The following criteria must be met for valid alignment data to be saved into receiver NVM.

- The INS solution status must be converged, as indicated by the INS solution convergence flag in the inertial Extended Solution Status.
- The system is stationary.

When these conditions are met, the required information is automatically saved to NVM. If these conditions cease to be met, the saved alignment data is automatically discarded. If the alignment data is discarded, error model information is automatically retained as appropriate.

Use at boot-up

Upon boot, checks are done to verify that any seed data existing in NVM is appropriate for use. These checks require a GNSS position to be computed, so an NVM seed will never use the INJECTED status prior to achieving a GNSS position. The following criteria must be met in order to use a seed:

- Seed data from NVM must be valid
- The system must not have changed more than 10 degrees in heading

If the INJECT Error Model Option is selected, and a valid error model is present in the seed data from NVM, this will always be used, even if the system has exceeded attitude validation thresholds. This functionality may be disabled with the IGNORE Error Model Option

INJECT Option (Advanced Users Only)

There is an advanced option available to skip the second and third validation steps described in the boot-up section above. This can be used if GNSS is not available on power-up or if speed to achieve an alignment is imperative.

This option is for advanced users only. Forcing an injection of an NVM seed without the validation checks can cause an unstable INS solution if the vehicle has moved.

Apart from injecting the seed at start-up without validation, this will also remove some requirements typically asserted to allow the filter to converge. This will allow the system to run without GNSS adequately at start-up.

Example usage

Enabling functionality after FRESET:

1. Send the following command.

```
INSSEED ENABLE VALIDATE INJECT
```

2. Send the following command.

```
SAVECONFIG
```

Saving valid INS information:

1. Operate the system as normal, until the filter completes convergence.
2. Bring the system to a complete stop before powering off or resetting.

Using valid INS information on start-up:

1. Remain static while initializing.
2. Wait for the system to receive a valid position from GNSS.
3. If using ALIGN updates, INS Seed data will be validated and injected. If not, drive forward to validate and inject the INS Seed.

System indicators

The **INSSEEDSTATUS** log reports the seed injection status for the current power up and information on current seed validity. Refer the [OEM7 Commands and Logs Reference Manual](#) for more information about the **INSSEEDSTATUS** log.

The Extended Solution Status field in the **INSPVAX** log has bits that indicate if the alignment direction is verified, the Alignment type that occurred and NVM seed injection status.

Alignment direction verified: Bit 25

This bit indicates whether the alignment is verified or not. When the seed is injected and kinematic validation is finished, bit 25 is set to 1. Note that this bit will not be set until the kinematic validation completes. When the INJECT option is used, validation is skipped and this bit will not be set.

Alignment type: Bits 26-28

These bits indicate how the INS system reached INS_ALIGNMENT_COMPLETE. When the INS system aligns using saved INS solution data from NVM, bits 26-28 will be set to 101

NVM seed status: Bits 29-31

These bits indicate the current status of the seeding process at start-up, as described in the table below:

Table 13: NVM seed indication

Bit 31-29 values ¹	Hex value	NVM seed type
001	0x01	INS Seed in non-volatile memory is invalid
010	0x02	INS Seed has failed validation and has been discarded
011	0x03	INS Seed is pending validation
100	0x04	INS Seed alignment data has successfully been injected

4.5.3 Navigation mode

Once the alignment routine has successfully completed, SPAN enters navigation mode.

SPAN computes the solution by accumulating velocity and rotation increments from the IMU to generate position, velocity and attitude. SPAN models system errors by using a filter. The GNSS solution, phase observations and automatic zero velocity updates (ZUPTs) provide updates to the filter. Peripheral updates can also be supplied; wheel sensor for displacement updates or heading updates.

Following the alignment, the attitude is coarsely defined, especially in heading. Vehicle dynamics, specifically turns, stops and starts, allow the system to observe the heading error and allows the heading accuracy to converge. The amount of dynamics required for filter convergence vary by the alignment quality, IMU quality, and manoeuvres performed. The INS Status field changes to INS_SOLUTION_GOOD once convergence is complete. If the filter degrades in its system accuracy, the INS Status field changes to INS_HIGH_VARIANCE. When the accuracy converges again, the INS status continues as INS_SOLUTION_GOOD.

While in navigation mode (in firmware versions 7.09.00 or greater), SPAN operates an internal secondary INS filter for built-in redundancy and reliability. When a verified GNSS solution of sufficient quality is available, the primary and secondary filters are validated against the GNSS solution. If divergence between the primary filter and the GNSS solution is detected, SPAN position, velocity and attitude output will fall back to using the secondary filter solution. This allows the system to reinitialize the primary filter if the divergence cannot be recovered, without interruption to the system's position, velocity and attitude output. Once the primary INS filter returns to normal operation (through recovery or reinitialization), the INS solution will revert back to the primary filter.

The system will flag bit 22 of the INS Extended Solution Status (see the [OEM7 Commands and Logs Reference Manual](#)) to indicate whenever the secondary INS solution is in use.

4.5.4 Data collection

The INS solution is available in the INS-specific logs with either a standard or short header. Other parameters are available in the logs shown in *Table 14: Solution parameters* below:

Table 14: Solution parameters

Parameter	Logs	
Position	INSPOS or INSPOSS INSPVA or INSPVAS	INSPOSX or INSPVAX

1. The values from left to right are Bit 31, Bit 30 and Bit 29.

Parameter	Logs	
Velocity	INSVEL or INSVELS INSPD or INSPDS INSPVA or INSPVAS	INSVELX or INSPVAX
Attitude	INSATT or INSATTS INSPVA or INSPVAS	INSATTX or INSPVAX
Solution Uncertainty	INSSTDEV or INSSTDEVS	



The **INSATTX** log, **INSPOX** log, **INSPVAX** log and **INSVELX** log contain solution and variance information and are therefore large logs. Use a low logging rate (<20 Hz) only. These logs also contain solution uncertainty in standard deviation format.

Note that the position, velocity and attitude are available together in the **INSPVA** log, **INSPVAS** log and **INSPVAX** log.

The inertial solution is available up to a rate of 200 Hz. Data can be requested at a specific synchronous time interval, asynchronously matching the IMU output rate, or can be triggered by the mark input trigger at rates up to 200 Hz.

The GNSS-only solution is still available through the GNSS-only logs such as RTKPOS and PSRPOS. Refer to the [OEM7 Commands and Logs Reference Manual](#). INS-only data logging and output can be at rates of up to the rate of the IMU data.



The highest rate that you should request GNSS logs (RANGE, BESTPOS, RTKPOS, PSRPOS, and so on) while in INS operation is 5 Hz. If the receiver is not running INS (no IMU is attached), GNSS logs can be requested at rates up to 20 Hz.



Logging restriction important notice

Logging excessive amounts of high rate data can overload the system. When configuring the output for SPAN, NovAtel recommends that only one high rate (>50 Hz) message be configured for output at a time. It is possible to log more than one message at high rates, but doing so could have negative impacts on the system. Also, if logging 100/200 Hz data, always use the binary format and, if possible, the short header binary format (available on most INS logs).

For optimal performance, log only one high rate output at a time. These logs could be:

- Raw data for post processing
RAWIMUXSB ONNEW
 - RAWIMU logs are not valid with the ONTIME trigger. The raw IMU observations contained in these logs are sequential changes in velocity and rotation. As such, you can only use them for navigation if they are logged at their full rate. Refer to the [OEM7 Commands and Logs Reference Manual](#) for log and command details.
- Real time INS solution
IMURATEPVA ONNEW or IMURATEPVAS ONNEW
 - Other possible INS solution logs available at high rates are: INSPVASB, INSPOSSB, INSVELSB, INSATTSB

Specific logs need to be collected for post-processing. See *Data collection for post processing* on page 120.

To store data from an OEM7 receiver, connect the receiver to a computer running NovAtel Application Suite or other terminal program capable of recording data. On CPT7 receivers, you can also collect data on internal memory.

4.5.5 Recommended messages to be logged for SPAN data collection

Although every customer has a different application and setup, it is important to always log as much information about the GNSS and INS filters and the environment in which the survey is taking place. The following are the suggested messages that should be logged for every survey. Note that the list includes all necessary messages for post-processing in Inertial Explorer.

Recommended SPAN messages for OEM7

- LOG VERSIONB ONCHANGED
- LOG RXCONFIGB ONCE
- LOG RXSTATUSB ONCHANGED

- LOG RANGEB ONTIME 0.5
- LOG GPSEPHEMB ONALL¹
- LOG GLOEPHEMERISB ONALL²
- LOG GALFNAVEPHEMERISB ONALL³
- LOG GALINAVEPHEMERISB ONALL²
- LOG BDSEPHEMERISB ONALL⁴
- LOG QZSSEPHEMERISB ONALL⁵
- LOG NAVICEPHEMERISB ONALL⁶
- LOG BESTGNSSPOSB ONTIME 1
- LOG BESTGNSSVELB ONTIME 1
- LOG BESTPOSB ONTIME 1
- LOG RANGEB_1 ONTIME 0.5⁷

- LOG HEADING2B ONNEW⁶
- LOG RAWIMUSXB ONNEW
- LOG INSPVAXB ONTIME 1

1. For firmware version earlier than 7.09.01, use the ONNEW trigger.

2. Should be logged If tracking GLONASS. For firmware version earlier than 7.09.01, use the ONNEW trigger.

3. Should be logged If tracking Galileo. For firmware version earlier than 7.09.01, use the ONNEW trigger.

4. Should be logged If tracking BeiDou. For firmware version earlier than 7.09.01, use the ONNEW trigger.

5. Should be logged If tracking QZSS. For firmware version earlier than 7.09.01, use the ONNEW trigger.

6. Should be logged If tracking NavIC. For firmware version earlier than 7.09.01, use the ONNEW trigger.

7. Should be logged If using dual antennas.

- LOG INSCONFIGB ONCHANGED¹
- LOG INSUPDATESTATUSB ONNEW
- LOG DMICONFIGB ONCHANGED²
- LOG RAWDMIB ONNEW⁸

4.5.6 Body to vehicle frame rotation calibration routine

Kinematic alignment requires that the rotational offset between the vehicle and IMU Body frame (RBV) is known. If the angles are simple (that is, a simple rotation about one axis) the values can easily be entered manually through the **SETINSROTATION RBV** command. If the rotational offset is more complex (that is, rotation is about 2 or 3 axis), then the calibration routine provides a more accurate estimation of the values.

The steps for the calibration routine are:

1. Apply power to the CPT7.
2. Configure the SPAN system including an approximate IMU Body to Vehicle frame (RBV) rotation. See *SPAN configuration for CPT7* on page 92.
3. Ensure that an accurate lever arm has been entered into the system.
4. Perform an initial system alignment using one of the methods described in *System start-up and alignment techniques* on page 100. Ensure the system reaches Solution Good.
5. Enable calibration using the **INSCALIBRATE** command with an optional standard deviation target.

```
INSCALIBRATE RBV NEW [target_stdev]
```

6. To monitor the calibration, log INSCALSTATUS using the ONCHANGED trigger.
7. Start to move the system. Movement of the system is required for the observation of the angular offsets.

Drive a straight course on level ground (remember that most roads have a crown resulting in a constant roll of a few degrees). Avoid driving on a surface with a constant, non-zero, slope to prevent biases in the computed angles. Vehicle speed must be greater than 5 m/s (18 km/hr) for the calibration to complete.

8. When the calibration is complete, either because the accuracy requirement has been met, or the calibration been stopped by user command (**INSCALIBRATE** command), the calibrated offset value is automatically applied can be viewed in either the **INSCALSTATUS** log or the **INSCONFIG** log.

To save a calibrated rotation for subsequent start ups, issue the **SAVECONFIG** command after calibration is complete. Each time the IMU is re-mounted this calibration should be performed again. See also *Kinematic alignment* on page 102 for details on kinematic alignment.



After the INSCALIBRATE RBV ENABLE command is entered, there are no body-vehicle rotation parameters present and a kinematic alignment is NOT possible. Therefore this command should only be entered after the system has performed a kinematic alignment and has a valid INS solution.

1. Can change ONCHANGED to ONTIME 600 to ensure the message is recorded.
2. Should be logged if using DMI.



As with the **SETINSROTATION** command, the minimum standard deviation that will be applied is 0.25 degrees (as viewed in the **INSCONFIG** log), even though the **INSCALSTATUS** log may report lower standard deviations after a successful calibration.



For information about the logs and commands used in this procedure, refer to the [OEM7 Commands and Logs Reference Manual](#).

4.5.7 Multi-line body to vehicle frame rotation calibration routine

The single pass Body to Vehicle frame offset calibration feature assumes flat ground when estimating the roll offsets between the IMU Body and Vehicle frames, as this component of the rotational offset is difficult to observe through typical ground vehicle motion. In practice this can result in an outstanding roll offset error as high as several degrees. For applications where vehicle roll must be well known, or pass-to-pass accuracy of a highly offset position is especially important, the Multi-Line IMU Body to Vehicle frame offset calibration routine offers higher calibrated accuracy in roll. This is done by running independent calibrations over the same ground path in opposite directions; averaging the results cancels out the effect of any terrain induced roll. A minimum of two iterations are required. Additional iteration pairs can be executed for increased reliability.

Figure 30: Multi-line IMU body to vehicle calibration

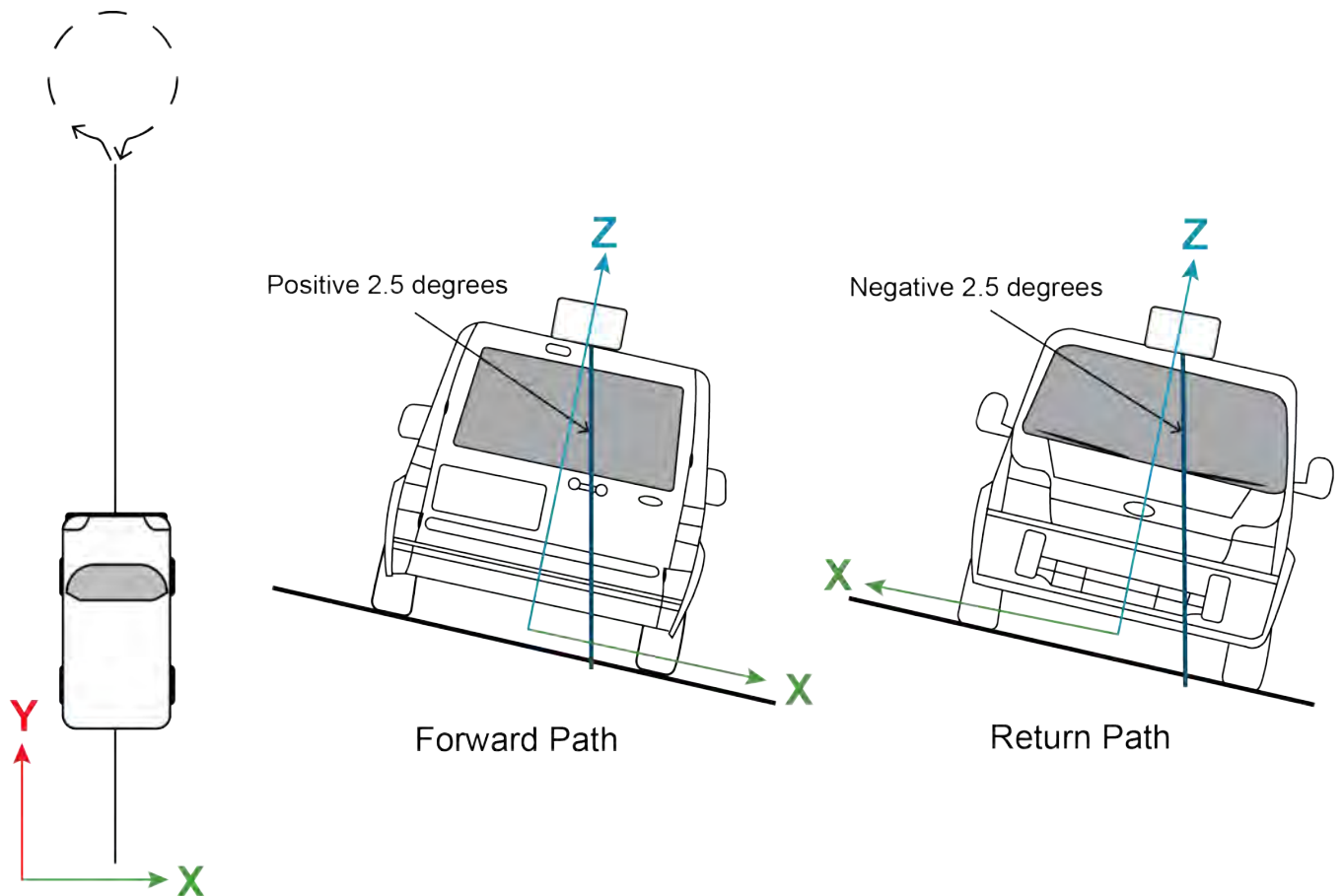

The steps for the calibration routine are:

1. Apply power to the CPT7.
2. Configure the SPAN system, see *SPAN configuration for CPT7* on page 92.
3. Ensure that an accurate lever arm has been entered into the system.
4. Perform an initial system alignment using one of the methods described in *System start-up and alignment techniques* on page 100. Ensure the system reaches Solution Good.
5. Enable a new calibration using the **INSCALIBRATE** command, with the optional standard deviation target omitted:

```
INSCALIBRATE RBV NEW
```

6. Start to move the vehicle. Drive a straight course, at a vehicle speed greater than 5 m/s (18 km/hr). A distance of approximately 250 metres is recommended.

To monitor the calibration, log **INSCALSTATUS** using the ONCHANGED trigger.

7. When the end of the available distance is reached, stop the vehicle. Halt the ongoing calibration by sending the **INSCALIBRATE** command again:

```
INSCALIBRATE RBV STOP
```

8. At this point **INSCALSTATUS** will report a source status of CALIBRATED. Turn the vehicle around and come to a stop on the finishing point of the previous line.
9. Initiate the second pass of the calibration by issuing the **INSCALIBRATE** command with the **ADD** parameter:

```
INSCALIBRATE RBV ADD
```

10. Drive the vehicle back along the original course, until you reach the starting point for the first pass. Stop the vehicle, and re-issue the **INSCALIBRATE** command, with the **STOP** parameter. **INSCALSTATUS** will again indicate a source status of CALIBRATED.

At this point the Multi-Line calibration can be considered complete, but more iterations can be repeated until the desired accuracy level is reached.

At any point during an active calibration line, the **INSCALIBRATE** command, with the **RESET** parameter can be used to reset the calibration. This will ensure that the results of the active line are not added to the Multi-Line calibration. The **INSCALSTATUS** log will restore the previous source status and calibration values.

11. When the calibration is complete, the calibrated offset value can be viewed in either the **INSCALSTATUS** log or the **INSCONFIG** log.

To save a calibrated rotation for subsequent start ups, issue the **SAVECONFIG** command after calibration is complete. Each time the IMU is re-mounted this calibration should be performed again.



Do not start INS Calibrations (NEW or ADD) until the inertial alignment is completed and system has converged.



For information about the logs and commands used in this procedure, refer to the [OEM7 Commands and Logs Reference Manual](#).

4.6 Distance Measurement Instrument

A Distance Measurement Instrument (DMI) can provide additional accuracy and reliability to a NovAtel SPAN solution. Specifically, a DMI can help constrain INS position and azimuth error growth during GNSS outages. The lower the IMU grade, the greater the DMI will help in constraining INS error drifts.

Typically, a DMI measures the distance travelled and represents the measurement using digital pulses. For a land vehicle, where a DMI is also known as a wheel sensor (odometer), the pulses are referred to as wheel ticks. If the pulses are accumulated and the size of the wheel known, a displacement of the wheel over time can be calculated. The SPAN system takes in a DMI input and applies a displacement update to the GNSS+INS Kalman filter in order to constrain the position error growth during GNSS outages. SPAN also automatically estimates the size of the wheel to mitigate small changes in the size of the wheel due to hardware changes or environmental conditions.

A DMI with a higher accuracy will have more wheel ticks per revolution. For example, assume a wheel with a circumference of 2 metres and a DMI rated for 1000 ticks per revolution. The DMI will output 1000 pulses per complete revolution of the wheel. The resulting precision will be 0.002 m/tick. Given the same wheel, but a DMI rated for 10 ticks per revolution, the resulting precision will be 0.2 m/tick.

4.6.1 DMI communication

The CPT7 supports single channel DMI data transmission using a pair of complementary signals represented as A+ and A-. Differential signals resist electromagnetic (EM) noise and improve robustness in challenging electrical environments compared to a single-ended pulse. Single channel connections provide benefit to the SPAN solution by measuring the distance travelled without regard for direction.



DMIs that use the Differential method may use a separate direction signal or index signal. These additional signals are currently not supported directly, but may be used with an intermediate processor. The Pulse or Differential part of the interface may still be used directly.

4.6.2 DMI connection

For a SPAN system with a CPT7, the DMI can be connected to the DMI input on the IO2 connector. For information about connecting and configuring a DMI to a CPT7, see *DMI connected to a CPT7* on page 114.

4.6.3 DMI requirements

The CPT7 is compatible with any wheel sensor meeting the following requirements:

- Output signal duty cycle is symmetric 40% to 60%.
- Output signal voltage is RS-422 compliant (differential).
- The wheel sensor is powered externally. The receiver does not supply power to the wheel sensor.
- Pulse and direction wheel sensors are compatible.
- Expected maximum pulse rate over measurement range does not exceed 100,000 Hz

An example of a compatible DMI is the Kistler Wheel Pulse Transducer CWPTA411 (WPT). See *Figure 31: Kistler WPT* on the next page.

- A transducer traditionally fits to the outside of a non-drive wheel. A pulse is then generated from the transducer which is fed to the receiver.
- The WPT mounts to the wheel lug nuts via adjustable mounting collets. The torsion protection rod, which maintains rotation around the wheel axis, affixes to the vehicle body with suction cups. Refer to the Kistler WPT (part number CWPTA411) user manual for mounting instructions.

Figure 31: Kistler WPT



Kistler provides an M12 to DB9 cable for use with the WPT DMI. However, certain revisions of this cable do not bring through all four signal inputs. SPAN systems require at a minimum the A+ and A- signals for distance. All four signal inputs are required to measure both distance and direction correctly. See your WPT documentation for cable details.

Table 15: Kistler to NovAtel wheel sensor cable connections

Kistler cable		CPT7
M12 connector		IO2 Cable
Pin	Signal	Pin on AUX 2
Pin 1	GND	Pin 8
Pin 2	+U _B (Input Power)	External
Pin 3	Signal A+	Pin 14
Pin 4	Signal A-	Pin 15
Pin 5	Signal B+	No connection
Pin 6	Signal B-	
Pin 7	Reserved	No connection
Pin 8		



This modification is for the Kistler WPT 8-pin M12-plug cable number 14865.



The WPT requires power to operate, which is not supplied through the CPT7. Pins 1 and 2 should therefore be connected to an external power supply (+10 to +30 VDC).

4.6.4 DMI connected to a CPT7

Figure 32: DMI to CPT7 setup below shows an overview of a DMI connected to a CPT7.



The CPT7 can accept DMI data from only one DMI.

Figure 32: DMI to CPT7 setup

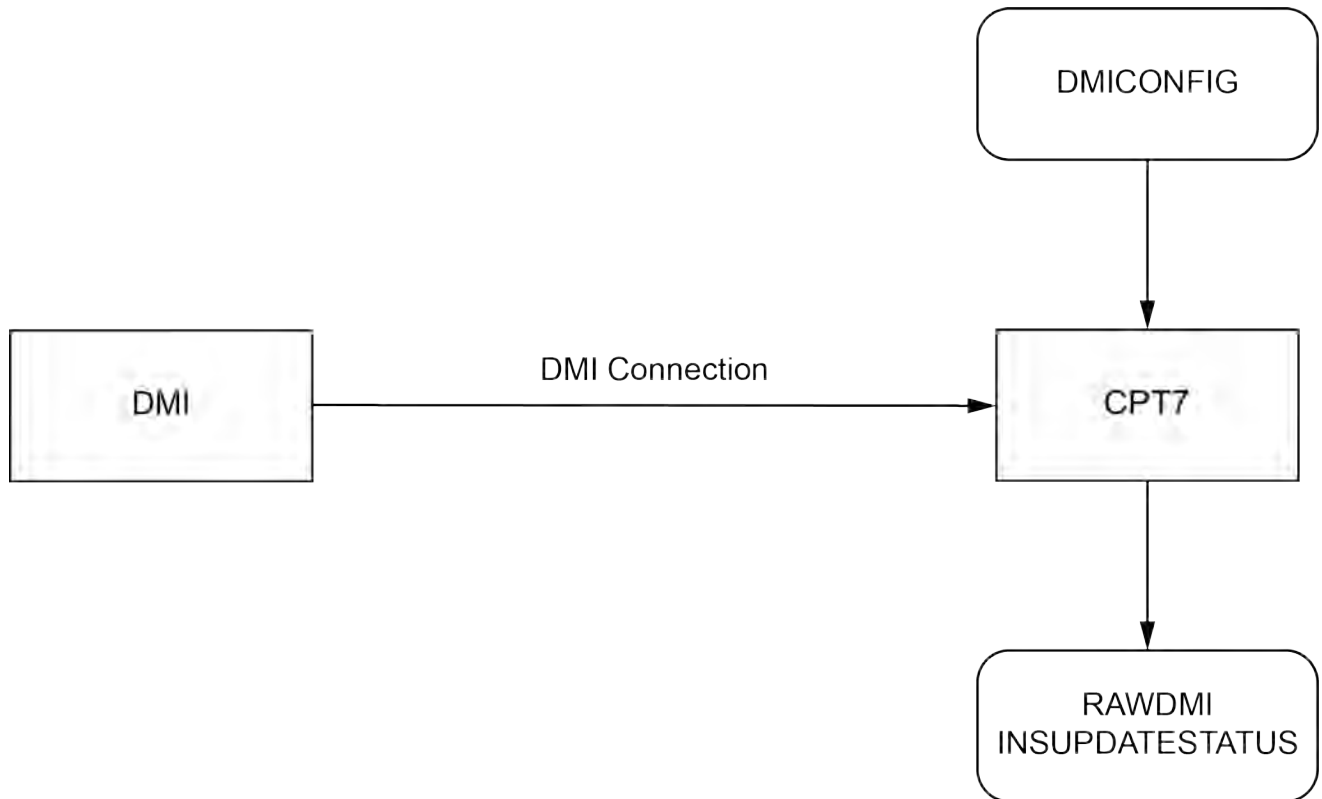

The DMI connections are A+, A- and GND.

DMI data collected on the CPT7

Typical DMI hardware generates wheel ticks constantly as the wheel rotates. The CPT7 interface is configured to accumulate wheel tick counts at a rate of 1 Hz.

DMI update logic

DMI data is available through the **RAWDMI** log. The **RAWDMI** log can be used for applying DMI updates in post-processing.

The SPAN filter uses sequential **RAWDMI** logs to compute a distance travelled between update intervals (1 Hz). This information is used to constrain free inertial drift during times of poor GNSS visibility. The filter also

contains a state for modelling the circumference of the wheel as it may change due to hardware changes or environmental conditions.

Information about how the DMI updates are being used is available in the **INSUPDATESTATUS** log.

Connect the DMI to a CPT7

The CPT7 DMI inputs are RS-422 differential inputs. Refer to *Table 34: CPT7 wheel sensor input signal levels* on page 196 for the required input voltages.

To connect a DMI:

1. Connect the CPT7 I/O2 Cable, or custom interface cable, to the IO2 connector on the CPT7.
For information about creating a custom interface cable, see *CPT7 I/O2 cable* on page 204.
2. Connect the DMI to the DMI A+ (Pin 14), DMI A- (pin 15) and GND (pin 8) connections on the AUX 2 connector.
3. Connect an external power supply to the DMI.
The power required for the DMI depends on the DMI used. Refer to the DMI user documents for more information.

Configure a DMI

1. Send the following command to enable a DMI on the CPT7 wheel sensor inputs.

```
DMICONFIG DMI1 ENABLE ENCLOSURE
```

2. Send the following commands to log the DMI data.

```
LOG DMICONFIGA ONCHANGED
```

```
LOG RAWDMIA ONNEW
```

```
LOG INSUPDATESTATUSA ONNEW
```

3. Check the **RAWDMI** log to ensure the DMI is producing data.
4. Check the **INSUPDATESTATUS** log to ensure the DMI is being used in the SPAN solution.

If there is no DMI data being produced or the DMI status is not USED, refer to *DMI troubleshooting* on the next page.



For more information, see the **DMICONFIG** command, **RAWDMI** log and **INSUPDATESTATUS** log in the [OEM7 Commands and Logs Reference Manual](#).

4.6.5 DMI command compatibility

With the introduction of the new streamlined command and log set for DMI use, legacy commands and logs have been deprecated.

Table 16: DMI command and log compatibility

Firmware 7.06.xx and earlier	Type	Firmware 7.07.00 and later	Type
WHEELVELOCITY ¹	Command	RAWDMI	Log/Command

1. The WHEELVELOCITY command will still be accepted in 7.07.00 and newer firmware with a limited capability. WHEELVELOCITY's cumulative tick field will be mapped to a RAWDMI command for backwards compatibility.

Firmware 7.06.xx and earlier	Type	Firmware 7.07.00 and later	Type
TIMEDWHEELDATA	Log	RAWDMI	Log/Command
WHEELSIZE	Log	None	
INSWHEELUPDATE	Command	None	
SETWHEELPARAMETERS	Command	DMICONFIG	Command
ENCLOSUREWHEELSENSOR	Command	DMICONFIG	Command

For firmware versions 7.06.xx and earlier, refer to docs.novatel.com/OEM7/Content/Appendix/PreviousVersionsDocument.htm for information about the legacy commands and logs.

4.6.6 DMI troubleshooting

Confirming that a DMI is setup and communicating properly within the entire system is important. Once all the hardware is setup, and the necessary commands have been issued, use the following checklist to ensure that the DMI information is being created and used:

- **RAWDMI** logs are being published by the receiver.
- **RAWDMI** logs have valid data (when in motion the value in the RAWDMI log will increase).
- DMISTATUS in the **INSUPDATESTATUS** log reports a status greater than or equal to ACTIVE.

If there are no valid **RAWDMI** logs being published from the receiver then debugging the hardware connections and setup commands may be required. Check the following:

- All communication lines are connected to the DMI.
- The DMI is being powered.
- The receiver is being powered.
- The DMI has been enabled through a **DMICONFIG** command.
- The receiver has the latest NovAtel Firmware, available from the NovAtel website (novatel.com/support/support-materials/firmware-download).
- The receiver has a valid SPAN model for use with DMI.

Further electrical troubleshooting may be required to verify signal integrity. In many cases, note the following.

- Cable shields should be tied to the connector shells and the metallized backshells/housings should be in contact with the connector shells as well.
- A +/- differential pairs should be on twisted pairs in the cables.



DMI input is not supported on Legacy CPT7 receivers (PN 80023560).

4.7 Synchronizing external equipment

A SPAN system allows you to synchronize with external equipment.

All SPAN-enabled receivers accept input pulses (events). Each event signal can be configured for positive or negative polarity. Time, or a solution (position, velocity, attitude), can be generated and output with each input pulse.

4.7.1 Configuring an input strobe

SPAN systems have several input strobes. The input strobes apply an accurate GNSS time to the rising, or falling, edge of an input pulse called an event. For each event, an accurate position, velocity or attitude solution is also available. Each input strobe is usually associated with a separate device, therefore different solution output lever arm offsets can be applied to each strobe.

Each input strobe can be configured using the **EVENTINCONTROL** command for the following parameters:

Polarity:

When polarity is set to positive, events trigger on the rising edge. When polarity is set to negative, events trigger on the falling edge.

Time Bias (t_bias):

A constant time bias in nanoseconds can be applied to each event pulse. Typically this is used to account for a transmission delay.

Time Guard (t_guard):

The time guard specifies the minimum number of milliseconds between pulses. This is used to coarsely filter the input pulses.

The time of the input pulses is available from the **MARKTIME**, **MARK2TIME**, **MARK3TIME** and **MARK4TIME** log. The solution synchronous with the event pulses is available from the **MARK1PVA**, **MARK2PVA**, **MARK3PVA** and **MARK4PVA** log. The logs required for input strobes are:

LOG MARK1TIMEB ONNEW

Output time for every pulse received.

LOG MARK1PVAB ONNEW

Output time, position, velocity and attitude for every pulse received at the location specified by the **SETINSTRANSLATION** command and **SETINSROTATION** command.

The above example is for the MARK1 event input. The minimum detectable pulse duration must be greater than or equal to 1 microsecond.



The input signal levels are 3.3 V to 0 V. Signal voltages outside these bounds damage the receiver.



For information about the logs and commands used in this procedure, refer to the [OEM7 Commands and Logs Reference Manual](#).

4.8 Adding timed sensor triggers

Use the EVENT IN and EVENT OUT connections to attach up to three sensor devices to an OEM7 receiver and then trigger the sensors based upon GPS time.

In this context a 'sensor' is any external device. The 'sensor' reference in the receiver is an object consisting of an Event_In and Event_Out pair of system strobes all linked by a sensor identifier.

You can send multiple trigger events marked with a user-specified ID and a GPS time to trigger the sensor. At the requested trigger time, the receiver outputs a user-specified pulse to the sensor and waits for a response pulse to indicate a sensor measurement (i.e. camera exposure). When this response is received, the SPAN system outputs a log with the inertial position/velocity/attitude and the ID of the event.



For information about the EVENT IN and EVENT OUT signal levels, refer to *CPT7 strobe specifications* on page 199.

4.8.1 Configuring the hardware

A sensor's trigger input is connected to a valid Event_Out and the sensor's response output is connected to a valid Event_In. Three sensor slots are available for use, but may be limited to less depending on the hardware platform used.

Table 17: Valid event inputs and outputs for timed sensor triggers

Valid event outputs	Valid event inputs
MARK1	MARK1
MARK2	MARK2
MARK3	MARK3

4.8.2 Configuring the software

Sensor objects are defined by using the **SETUPSENSOR** command. This command allows the Event_In and Event_Out lines to be specified as well as some parameters for the outgoing and incoming signals.



After configuring a sensor using the **SETUPSENSOR** command, any other commands that affect the selected event lines will disturb this functionality. For example, if MARK2 Out is selected for a sensor, but later the **EVENTOUTCONTROL** command is sent, the **EVENTOUTCONTROL** command will reconfigure the properties of the MARK2 line.

4.8.3 Using timed event pulses

When sensors have been connected and configured, use the **TIMEEVENTPULSE** command to queue events on the system. **TIMEEVENTPULSE** specifies the sensors that are affected, the GPS time for the desired event (in weeks and seconds), and an event ID. You can queue 10 unprocessed events at a time. Any time input specified via this command must occur at least 1 second after the command is entered.

The timing accuracy of the **TIMEEVENTPULSE** output is 2 milliseconds.

4.8.4 Recording incoming sensor events

After a **TIMEEVENTPULSE** is sent, the system can be configured to accept an incoming pulse from the sensor in order to produce a time and ID tagged inertial solution associated to that event. This is optional and useful if a sensor provides a measurement TOV pulse. The produced log is a TAGGEDxMARKPVA where the 'x' is the Event_In line associated with that sensor (via the **SETUPSENSOR** command).

For example, if the **SETUPSENSOR** command specifies SENSOR1 to use MARK1 in as the input event then a TAGGEDMARK1PVA log will be produced when any pulses on that line are observed. In this case the TAGGEDMARK1PVA log should be requested ONNEW to capture the data.

4.9 Azimuth sources on a SPAN system

The SPAN system use three different methods to calculate the azimuth.

- Course over ground
- Inertial azimuth
- ALIGN azimuth

4.9.1 Course over ground

The course over ground azimuth is determined using the position delta between two position solutions computed by the OEM7 receiver. This is the simplest way to compute an azimuth and is done using either the GNSS solution or the INS solution. This method does not work when the vehicle is stationary as any position difference is due to position error and the computed azimuth is meaningless.

Course over ground azimuth is of greatest advantage in aerial or marine environments where the actual direction of travel may not match the forward axis of the aircraft/boat due to winds or currents. This effect is known as the crab angle. Course over ground azimuth is a great way to compute the offset if another means of computing the vehicle azimuth is available.

Course over ground azimuths are available in several different velocity logs. See *Table 18: Logs with azimuth data* below.

4.9.2 Inertial azimuth

The inertial azimuth computed by the SPAN inertial navigation filter. It uses the sensors in the IMU to compute the azimuth of the IMU (this can be rotated to another reference if desired). For more information, see the **SETINSROTATION** command in the [OEM7 Commands and Logs Reference Manual](#).

This azimuth is the one provided in the majority of the INS logs available to a SPAN user. See *Table 18: Logs with azimuth data* below.

4.9.3 ALIGN azimuth

On SPAN systems with dual antennas, an azimuth is available from the dual antenna baseline. This is the same azimuth that is used as an update to the SPAN solution. It is noisier than the inertial azimuth and is available at a much lower rate, but will have a stable mean. This azimuth is computed from the base antenna to the rover antenna based on how the antennas are oriented on the vehicle.

There is a specific subset of logs that output this azimuth. See *Table 18: Logs with azimuth data* below.

Table 18: Logs with azimuth data

Log	Log format	Azimuth source
BESTGNSSVEL	NovAtel	Course over ground From the best GNSS only solution
BESTVEL	NovAtel	Course over ground From the best system solution which could be either GNSS or INS
GPHDT	NMEA	ALIGN
GPVTG	NMEA	Course over ground From the best system solution which could be either GNSS or INS

Log	Log format	Azimuth source
HEADING2 / DUALANTENNAHEADING	NovAtel	ALIGN
INSATT / INSATTS / INSATTX	NovAtel	Inertial
INSPVA / INSPVAS / INSPVAX	NovAtel	Inertial
INSSPD	NovAtel	Course over ground Computed using the INS solution only
PASHR	NMEA	Inertial

4.10 Data collection for post processing

Some operations, such as aerial measurement systems, do not require real-time information from SPAN. These operations are able to generate the position, velocity or attitude solution post-mission in order to generate a more robust and accurate solution than is possible in real-time.

In order to generate a solution in post-processing, data must be simultaneously collected at a base station and each rover. The following logs must be collected in order to successfully post process data.

From a base:

- LOG VERSIONB ONCE
- LOG RXCONFIGB ONCE
- LOG RXSTATUSB ONCHANGED
- LOG THISANTENNATYPEB ONCE
- LOG RANGECMPB ONTIME 1
- LOG RANGECMPB_1 ONTIME 1
- LOG GPSEPHEMB ONNEW
- LOG GLOEPHEMERISB ONNEW (if using GLONASS)
- LOG GALINAVEPHEMERISB ONNEW (if using Galileo)
- LOG GALFNAVEPHEMERISB ONNEW (if using Galileo)
- LOG BDSEPHEMERISB ONNEW (if using BeiDou)
- LOG QZSSEPHEMERISB ONNEW (if using QZSS)

From a rover:

- LOG VERSIONB ONCE
- LOG RXCONFIGB ONCE
- LOG RXSTATUSB ONCHANGED
- LOG THISANTENNATYPEB ONCE
- LOG HEADING2B ONNEW
- LOG INSCONFIGB ONCHANGED
- LOG RANGECMPB ONTIME 1
- LOG GPSEPHEMB ONNEW

- LOG GLOEPHEMERISB ONNEW (if using GLONASS)
- LOG GALINAVEPHEMERISB ONNEW (if using Galileo)
- LOG GALFNAVEPHEMERISB ONNEW (if using Galileo)
- LOG BDSEPHHEMERISB ONNEW (if using BeiDou)
- LOG QZSSEPHHEMERISB ONNEW (if using QZSS)
- LOG RAWIMUSXB ONNEW
- LOG TIMEB ONTIME 1
- LOG BESTPOSB ONTIME 1
- LOG BESTGNSSPOSB ONTIME 1
- LOG INSPVAXB ONTIME 1
- LOG INSUPDATESTATUSB ONCHANGED
- LOG DMICONFIGB ONCHANGED (if using a DMI sensor)
- LOG RAWDMIB ONNEW (if using a DMI sensor)

Post processing is performed using Waypoint Inertial Explorer. Visit our web site at novatel.com/products/waypoint-software for details.



The highest rate that you should request GNSS logs (RANGE, BESTPOS, RTKPOS, PSRPOS, and so on) while in INS operation is 5 Hz. If the receiver is not running INS (no IMU is attached), GNSS logs can be requested at rates up to 20 Hz.



The choice between ONNEW and ONCHANGED is dependent on the type of data collection and user preferences. The ONNEW trigger can result in larger files with duplicate logs that are ignored by Inertial Explorer's converter. The ONCHANGED trigger is preferable to avoid duplicates and minimize file size. However, if the ONCHANGED log request is made before the logging file is opened the log will not be triggered until a value has changed. This may cause issues in short surveys, as slow changing logs (such as RAWEPHEMB) may not be logged during the data collection period. For this reason, ONNEW is suggested for short surveys.



No RAWDMIB logs will be decoded without the presence of a DMICONFIGB log. As such, users may consider logging this ONTIME at a coarse rate to ensure it is saved to file (e.g. LOG DMICONFIGB ONTIME 300).

4.11 Variable Lever Arm

The variable lever arm concept arose to support applications in which the IMU is no longer rigidly fixed to the vehicle, but rather on a gimballed mount. This creates an issue where the input lever arm offsets to the GNSS antenna are no longer correct, because the IMU can rotate on its mount, while the antenna remains fixed.

The use of the variable lever arm functionality requires that the device to which the IMU is attached be able to send its gimbal rotation angles back to SPAN. These angles are used to recalculate the lever arm at the rate that they are received. SPAN will also be able to output a gimballed solution at the rate the gimbal angles are received.

4.11.1 Reference frame description

There are several frames of reference involved when dealing with a gimballed mount. The frames are all very similar, but can be quite confusing due to small differences. Below are all frames applicable to the implementation of the variable lever arm:

Frame	Description	Notation
IMU Body frame	The physical IMU axes	(b)
Vehicle frame	Default reference frame for attitude output in SPAN logs	(v)
Mount body frame	The physical axes of the gimballed mount	(m)
Gimbal body frame	The physical axes of the gimbal plane. This frame matches the mount body frame when gimbal angles are zero and rotates relative to the mount body frame when the gimbal is active.	(g)
User Output Frame	An arbitrary frame, used to define the desired reference for attitude output, typically matching a gimbal mounted sensor	(ou)
Mark Output Frame	An arbitrary frame, used to define the desired reference for attitude output for the MARKxPVA logs, typically matching a gimbal mounted sensor	(om)

4.11.2 Example gimbal installation

Figure 33: Sample configuration on the next page and *Figure 34: Operating gimbal* on the next page illustrate a basic scenario for the information in the table above. *Figure 33: Sample configuration* on the next page shows a possible configuration for the mount body frame, IMU body frame and a user output frame, with the gimbal in a locked position. The extra rotation commands required to configure Variable Lever Arm for this setup are:

```
SETINSROTATION RBM 180 0 0
SETINSROTATION USER 0 0 90
SETINSROTATION RBV 0 0 -90
```

Figure 34: Operating gimbal on the next page shows the gimbal in operation; the gimbal platform has moved relative to the mount body frame. The gimbal frame and IMU Body frame move together, as does the user output (or mark output) frame.

Figure 33: Sample configuration

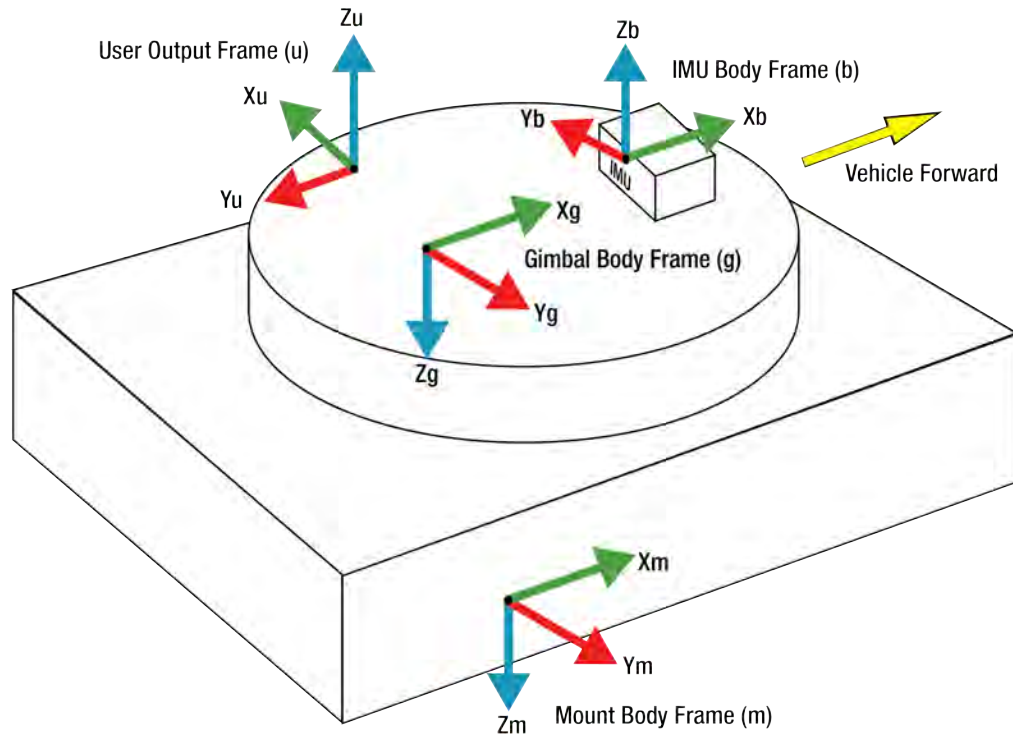
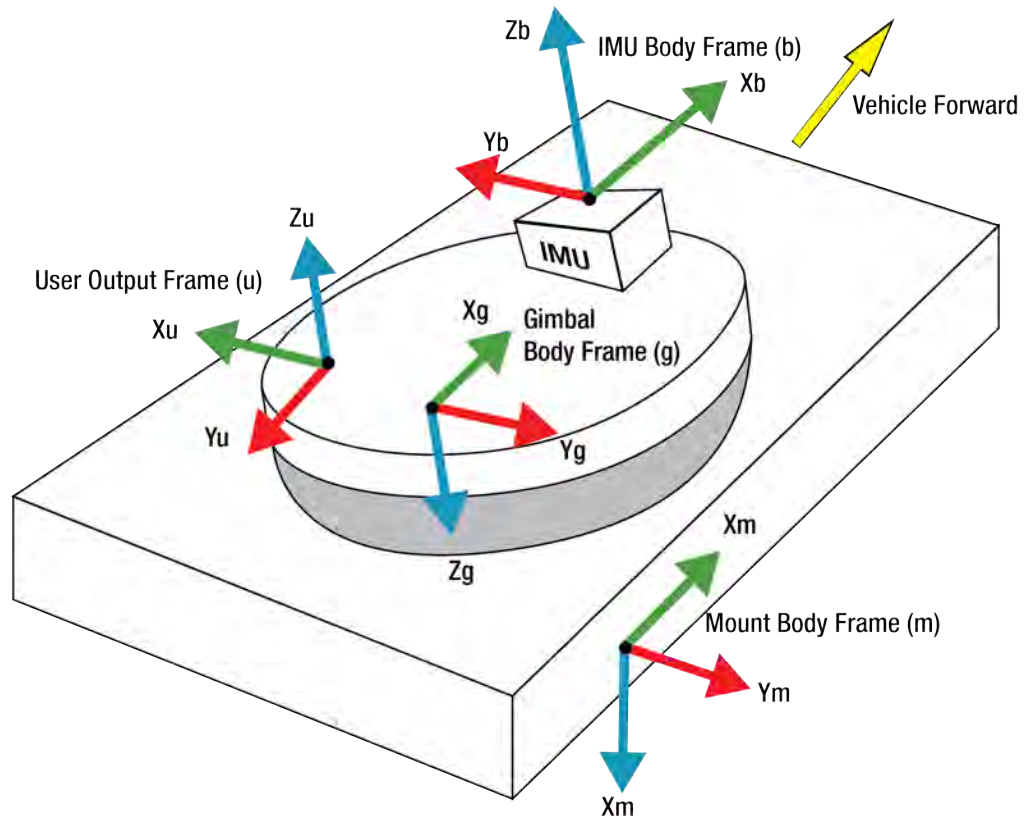

Figure 34: Operating gimbal



4.11.3 How to use Variable Lever Arm

The variable lever arm functionality requires the input of gimbal angles from a rotating camera mount or gimbal platform, on which a SPAN IMU is mounted. With input gimbal angles and the correct configuration, the SPAN system will compute a variable lever arm offset and produce gimbal-corrected messages.

Ensuring a proper variable lever arm is important for SPAN performance.

Basic I/O

The variable lever arm functionality is based on the input of the **INPUTGIMBALANGLE** command. This command specifies the right-handed rotation angles from the **mount body frame (m)** to the **gimbal body frame (g)**, with the order of rotations Z-X-Y. Entering this command will automatically cause the system to rotate the static lever arm into the latest gimballed frame. The update rate of the variable lever arm depends on the rate of the gimbal commands which can be entered at 1 to 50 Hz. If an **INPUTGIMBALANGLE** command is not received for over 1 second then the system will return to using the static lever arm.

In addition to using the variable lever arm internally, the following information is available to the user.

Table 19: Logs used with Variable Lever Arm

Log	Description
VARIABLELEVERARM	This log contains the re-calculated primary antenna (ANT1) translation offsets adjusted for the rotation defined by the INPUTGIMBALANGLE command. The VARIABLELEVERARM log is output in the IMU Body frame.
GIMBALLEDPVA	This log contains the INS position, velocity, and attitude rotated back into the gimbal null position. When the gimbal mount is in the zero/locked position, the GIMBALLEDPVA output will match the INSPVA log. The position and velocity is output at the IMU centre of navigation, unless a user output frame is defined (configured with the SETINSTRANSATION command). The attitude is output in the user output frame (configured with the SETINSROTATION command, default is Vehicle frame).
INSPVA, INSPVAS, INSPVAX	The INSPVA log is synchronous so does not depend on the entry of the INPUTGIMBALANGLE command. However when the gimbal angles are non-zero, the INSPVA log no longer represents the orientation of the gimbal mount / vehicle, but rather the current orientation of the unlocked gimbal platform. If the orientation of the vehicle is important, use the GIMBALLEDPVA log.

Rotations and translations

For the information provided by the system to be meaningful, the following offsets have to be set correctly. By default the system assumes that the IMU Body frame, gimbal mount and Mount Body frame are coincident. If this is not the case then additional commands are necessary to relate all of the different frames together using the commands below. If attitude output is desired relative to an external camera, this can also be configured using these commands.



When entering the **SETINSROTATION** commands described in the following table, the gimbal mount should be locked (**INPUTGIMBALANGLE** rotations are zero).

Table 20: Commands used with Variable Lever Arm

Command	Purpose
SETINSROTATION RBV	This command provides the orientation of the IMU Body frame while the gimbal frame is in the locked null position. This is required information before the SPAN system can complete an inertial alignment. The SETINSROTATION RBV command relates the IMU Body frame (b) to the Vehicle frame (v). Once an RBV rotation has been provided, default attitude output will be referenced to the Vehicle frame.
SETINSROTATION RBM	This command relates the IMU Body frame (b) to the Mount Body frame (m). This information is required for interpreting the rotation angles from the INPUTGIMBALANGLE command correctly.
SETINSROTATION USER	By default, attitude information output by SPAN is for the vehicle frame. If attitude output is required to be referenced to another frame (typically the axes of a gimbal-mounted sensor), the USER offset can be used to rotate the attitude output in general SPAN logs to this frame.
SETINSROTATION MARKx	Similar to the user rotation, this rotation can be used to change the attitude output reference frame for the MARKxPVA logs.
SETINSTRANSALATION GIMBAL	This command provides the translation offset from the IMU centre of navigation to the gimbal mount centre of rotation, used for proper variable lever arm computations.

4.12 Relative INS

NovAtel's Relative INS technology generates a position, velocity and full attitude vector between two SPAN systems. One is the Base receiver and the other is the Rover receiver. Once configured, the Base receiver begins transmitting corrections to the Rover receiver. Relative information is created and the system begins filling the **RELINSPVA** log and **SYNCRELINSPVA** log on the Rover receiver. The **RELINSPVA** log is then transmitted back to the Base receiver for output.

The data link required must be able to support [864bits+108bits x #obs tracked per second]. The **RELINSPVA** log is requested ONNEW (available from 1Hz-20Hz depending on the setup of the **RELINSAUTOMATION** command) while the **SYNCRELINSPVA** log can be requested ONTIME at up to 200Hz (at the rover only). Position and velocity solutions are differenced in the ECEF frame and then rotated into the local level. The Relative offset vector that is output is dependent on Base/Rover's precise RTK vector and their eccentric offset vectors (optional offset provided using the **USER** parameter in the **SETINSTRANSALATION** command), shown in *Figure 35: Relative INS example* on the next page.

Figure 35: Relative INS example

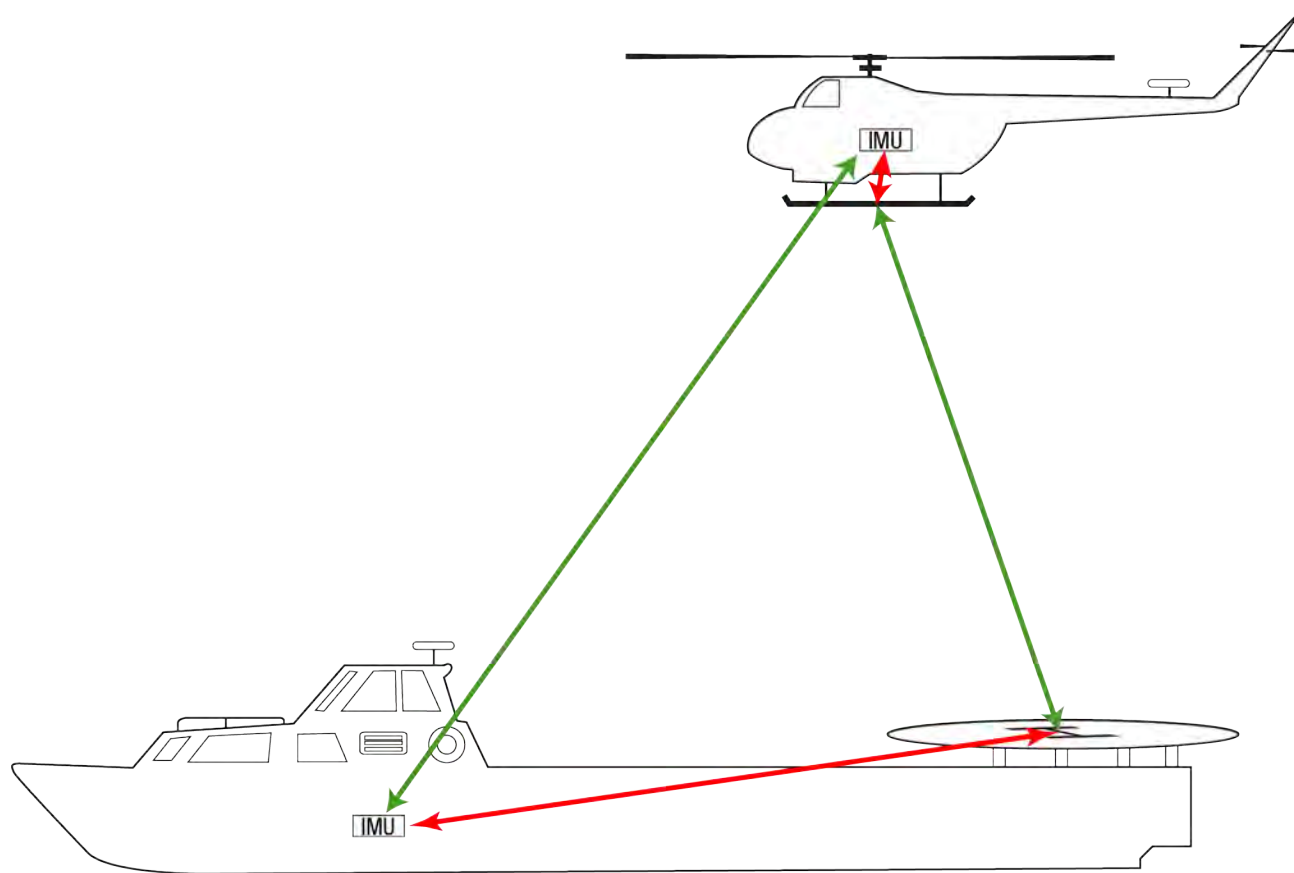

An important command that can be used with Relative INS to manually change the maximum amount of time to use RTK data is the **RTKTIMEOUT** command. This command is used to set the maximum age of RTK data to use when operating as a rover station. RTK data received that is older than the specified time is ignored.

The default is 60 seconds, however when using Relative INS, it is suggested this be set to 5 seconds by sending the command **RTKTIMEOUT 5**.



For information about the **RTKTIMEOUT** command, refer to the [OEM7 Commands and Logs Reference Manual](#).

4.12.1 Configure Relative INS

To configure the receivers to begin computing the relative information:

1. Setup a link between the receivers that will be used to transfer data (for example, radios).
2. Enable the transfer of relative corrections between receivers using one of the methods below.
 - Send the **RELINSAUTOMATION** command only at the Rover receiver
 - Send the **RELINSCONFIG** command at both the Base and Rover receiver



To configure Relative INS using the **RELINSAUTOMATION** command, the base and rover receivers must be communicating using a COM port. If the base and rover are communicating via an ICOM port, the **RELINSCONFIG** command must be used.



The base and rover receiver must be using the same datum.

Chapter 5 CPT7 with dual antenna

NovAtel's ALIGN heading technology generates a heading solution using the position information from the primary and secondary GNSS antenna. The CPT7700 requires a second receiver to generate an ALIGN solution. The CPT7 can provide an ALIGN solution without an additional receiver.

With SPAN, the ALIGN GNSS baseline can be used to assist the initial alignment of the SPAN solution. In addition, the ALIGN baseline solution will aid the heading solution from the receiver if the heading drifts due to slow or constant dynamics.

ALIGN is capable of a 10 Hz heading output rate.

 For optimal performance of Dual Antenna with SPAN, refer to the configuration details described in *Configuring dual antenna ALIGN with SPAN* on page 130.

5.1 Installation

The hardware for SPAN with Dual Antenna is installed in a manner similar to other SPAN systems. Some points to consider during your installation are:

1. Install the CPT7 and the two antennas in the vehicle such that the relative distance between them is fixed.
2. The antennas should be mounted with as clear a view of the sky as possible so each satellite above the horizon can be tracked with minimal obstruction. If using a dual antenna system, the GNSS ALIGN accuracy is dependent on antenna baseline length; hence mount the primary and secondary antennas as far apart as possible (a minimum separation distance of 1 metre is recommended).

In most scenarios, it is ideal to use the antenna closest to the IMU as the primary. However, it may be use case dependent given the installation location of both antennas.

3. The lever arms or distance from the CPT7 to the antennas needs to be fixed and accurately measured using the coordinate axes defined on the outside of the CPT7. The baseline between the two antennas does NOT need to be aligned with the vehicle axes or with the axes of the CPT7.
4. If using a CPT7700, the CPT7700 and the second receiver need to be powered and connected to each other via COM 2 before sending any configuration commands. It does not matter which receiver is powered on first, or how long they are both powered before sending any commands.



SPAN with Dual Antenna operation assumes the use of the COM 2 port for communication between receivers unless a different port is specified using the **INSALIGNCONFIG** command. This command can change the COM ports of the SPAN-enabled base and the rover, the baud rate used and data output rates.



For information about connecting the ALIGN base and rover receivers using a port that is not a serial COM port (e.g. Ethernet), contact NovAtel Customer Support.

For a CPT7700, the two receivers need to be set up as shown in the example in *Figure 36: SPAN – CPT7700 dual antenna installation* on the next page.

The CPT7 contains the hardware necessary to provide an ALIGN solution without an additional receiver. Set up a SPAN system with a dual antenna receiver as shown in *Figure 37: SPAN – CPT7 dual antenna installation* on the next page.

Figure 36: SPAN – CPT7700 dual antenna installation

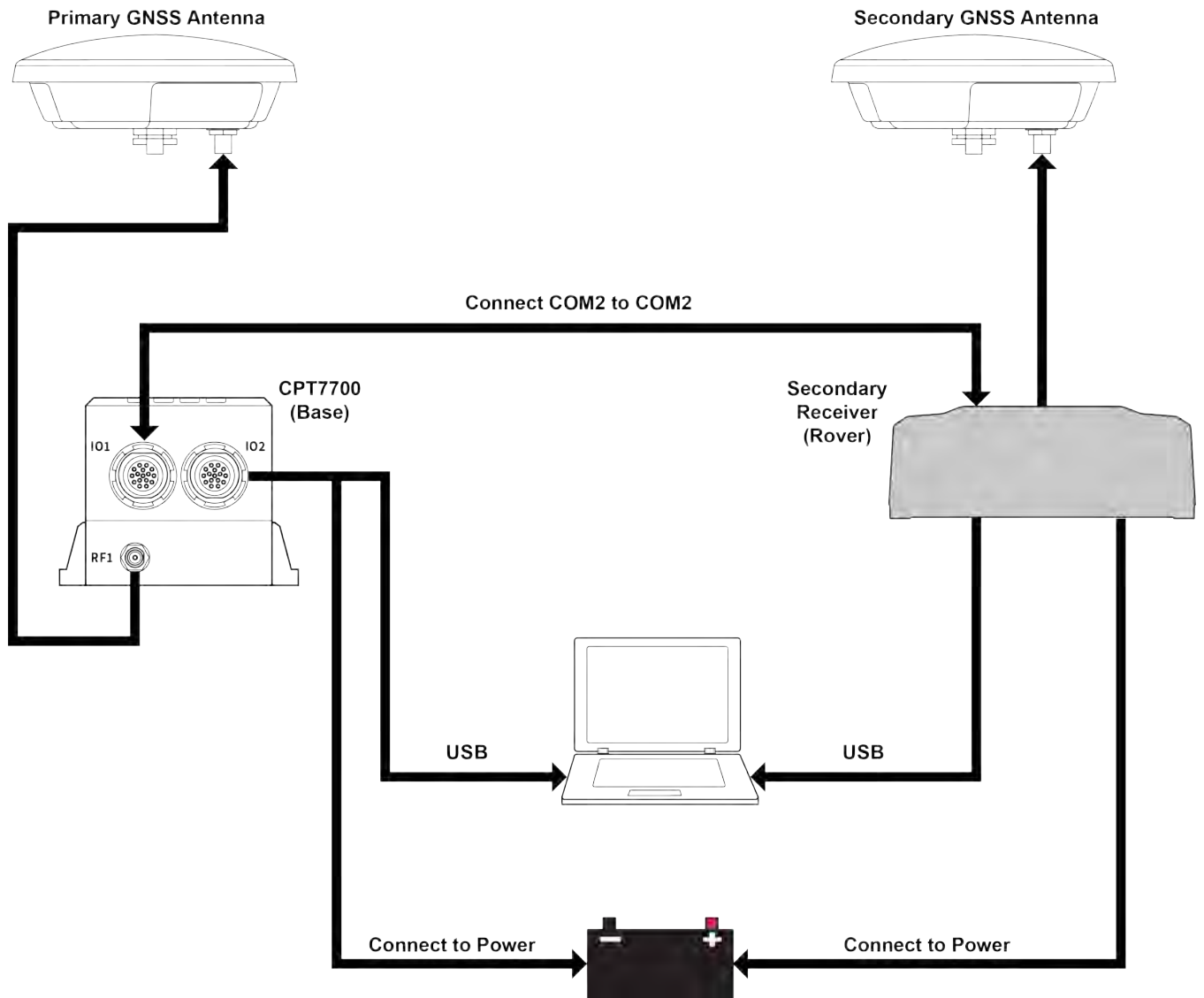

Install a user supplied 2 A slow blow fuse in the positive line of the connection to the power source.

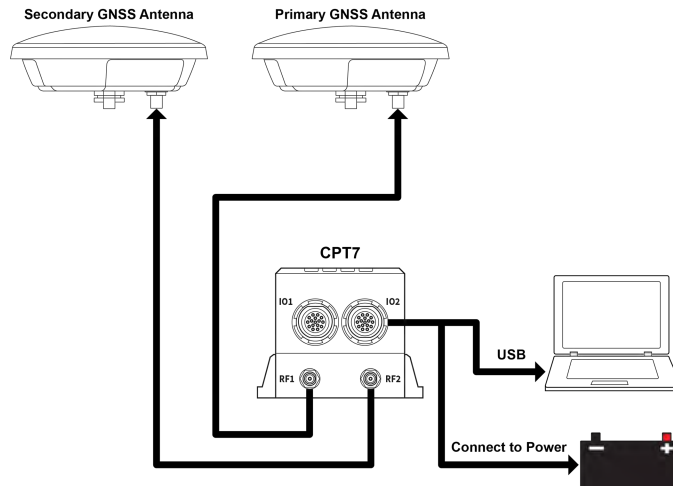
Figure 37: SPAN – CPT7 dual antenna installation

Install a user supplied 2 A slow blow fuse in the positive line of the connection to the power source.

5.2 Configuring dual antenna ALIGN with SPAN

The Dual Antenna ALIGN updates are used to help constrain the azimuth drift of the INS solution whenever possible. This is of the greatest value with lower-quality IMUs and in environments with low dynamics where the attitude error is less observable. Slow moving marine, agriculture and train applications are good examples of the intended use. By providing an external heading source, the solution drift can be constrained in these environments.

As with all ALIGN-capable products, the ALIGN solution is available from the **GPHDT** log and **HEADING2** log. For INS heading (azimuth), use the **INSATT** log, the **INSPVA** log, or any other desired SPAN log containing azimuth.

To monitor the status of the ALIGN update being applied, observe bit 4 of the **INS Extended Solution Status** field of the extended INS logs (INSATTX, INSPOSX, INSPVAX and INSVELX).

Following the appropriate dual antenna configuration below, the SPAN system can be configured for different alignment routines depending on the motion conditions experienced during the alignment period. The different alignment routines are described in *System start-up and alignment techniques* on page 100.

5.2.1 Setup and configuration

Dual Antenna ALIGN with SPAN can be configured on a dual-antenna receiver, e.g. OEM7720, or using two receivers. All dual-antenna receivers come with an ALIGN capable model. If using two receivers, the secondary non-SPAN receiver must be an ALIGN capable model. For additional information on models see the *Model List for NovAtel* (novatel.com/products/model-list-and-discontinued-products).

If using two receivers, both receivers should both be powered on, and a connection established between the SPAN receiver and the secondary non-SPAN receiver as shown in the example in *Figure 36: SPAN – CPT7700 dual antenna installation* on the previous page.

To enable the dual-antenna ALIGN solution to aid the INS alignment and provide heading updates, the offset between the antennas and the IMU must be known. This is achieved by entering lever arms to both antennas, using the **SETINSTRANSLATION** command.

To configure SPAN with ALIGN Aiding:

1. Enter the lever arm from the IMU to the primary antenna.

Abbreviated ASCII example:

```
SETINSTRANSFORMATION ANT1 0.54 0.32 1.20 0.03 0.03 0.05
```

2. Enter the lever arm from the IMU to the secondary antenna.

Abbreviated ASCII example:

```
SETINSTRANSFORMATION ANT2 0.54 2.32 1.20 0.03 0.03 0.05
```



Alternately, the angular offset between the dual-antenna baseline (from primary GNSS antenna to secondary GNSS antenna) and the IMU frame forward axis can be entered directly via the ALIGN parameter of the **SETINSROTATION** command.

It is recommended to enter the lever arms rather than entering the angular offset as the lever arms are easier to measure and will lead to better overall accuracy.

3. Use the **INSALIGNCONFIG** command to configure the connection ports, baud, and heading rate.



This command is not required for a dual-antenna receiver configuration, e.g. OEM7720, but can be used to adjust the heading rate – the port configuration fields will be ignored.

Abbreviated ASCII example:

```
INSALIGNCONFIG COM1 COM2 230400 5
```

For optimal performance of Dual Antenna with SPAN, an accurate ALIGN angular offset is required for each unique installation. This value can be calibrated should the entered ALIGN rotation value or value derived from the input lever arms be less accurate than 5 degrees. Refer to INSCALIBRATE command for details.

Refer to the [OEM7 Commands and Logs Reference Manual](#) for the syntax of the above commands.

5.2.2 Optional HEADINGOFFSET configuration

Optionally, the **HEADINGOFFSET** command can be used to rotate the ALIGN solution available in the **GPHDT** log and **HEADING2** log. This is occasionally desired when the baseline does not line up with the direction of travel but is not required for use with SPAN. If this additional offset in the **GPHDT** log and **HEADING2** log is desired, the following configuration details should be evaluated.

Most configurations of the HEADINGOFFSET command are not compatible with Waypoint Inertial Explorer and as such is not recommended for use if the data will be post processed. Contact support (see *Customer Support* on page 16) for more information.



The **HEADINGOFFSET** command will apply a rotational offset to the fields in the **HEADING2** log. This is handled differently depending on single receiver or dual receivers **ALIGN** setup, see below.

HEADINGOFFSET details when a dual-antenna receiver is used:

- The **HEADINGOFFSET** command will apply a rotational offset to the fields in **HEADING2** log. SPAN will automatically account for this additional rotation when applying the **ALIGN** update. As such, the provided **ANT2** translation or **ALIGN** rotation should match the physical installation as per the standard instructions.

HEADINGOFFSET details when two receivers are used:

- Option 1:
Issue the **HEADINGOFFSET** command on both the primary and secondary receivers. The secondary receiver will apply the rotational offset to the fields in the **HEADING2** logs being sent to the primary receiver. The primary receiver (running SPAN) will automatically account for this additional rotation when applying the **ALIGN** heading update. As such, the provided **ANT2** translation or **ALIGN** rotation should match the physical installation as per the standard instructions above.
- Option 2:
Issue the **HEADINGOFFSET** command on the secondary card where the **HEADING2** log is computed. This will apply a rotational offset to the fields in the **HEADING2** logs being sent to the primary card. The primary card (running SPAN) must be configured according to the offset orientation. This means that either the **ANT2** lever arm or the **ALIGN** rotation must be adjusted and entered such that they account for the offset heading orientation.

Chapter 6 Ethernet configuration

This chapter describes how to configure the Ethernet port on an OEM7 receiver. It provides the step-by-step process for connecting to the OEM7 receiver through the Ethernet interface, setting up a base/rover configuration through Ethernet connectivity and utilizing the NTRIP interface. The Ethernet port connections for a computer connected to the receiver are also described for Windows 7 operating systems.



In this chapter, references to OEM7 receivers includes the CPT7 and CPT7700.



The **SAVEETHERNETDATA** command can be issued to retain the Ethernet configuration settings after a **RESET/FRESET** command. The **ETHCONFIG** command and **IPCONFIG** command must be issued prior to using **SAVEETHERNETDATA** command. Refer to the [OEM7 Commands and Logs Reference Manual](#).

6.1 Required hardware

The following hardware is required to set up an Ethernet interface to an OEM7 receiver:

- a user supplied computer with an available Ethernet, serial or USB port
- a GNSS antenna
- an Ethernet capable OEM7 receiver
- an RS-232 null modem cable or USB cable
- one or two CAT5 Ethernet cables
- a user supplied Ethernet network, hub or wired router (optional)
- a coaxial antenna cable (50 Ω)

6.2 Static IP address configuration

For a static IP address configuration, unique IP addresses are assigned to both the OEM7 receiver and the computer. TCP/IP is used for the connection in this simple network. This configuration can also be used in a bench test environment to confirm Ethernet functionality.

For connections when an OEM7 receiver uses a static IP address configuration, refer to *Figure 38: Cross-over Ethernet cable configuration—OEM7 receiver* on the next page.

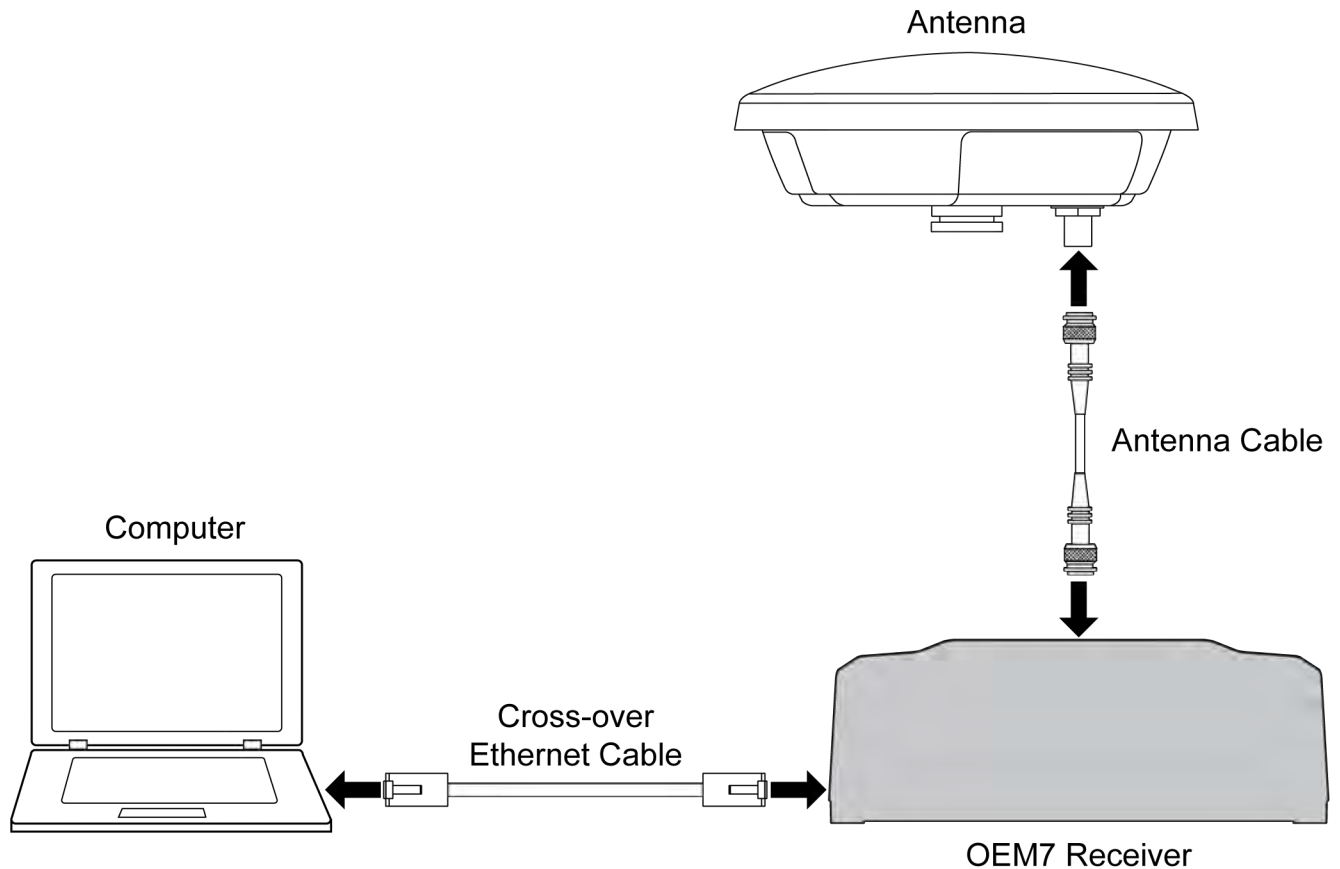
Figure 38: Cross-over Ethernet cable configuration—OEM7 receiver

6.2.1 Static IP address configuration—receiver

Follow these steps to set up a static IP address on the OEM7 receiver:

1. Connect a computer to the OEM7 receiver using a null modem serial cable or USB cable.
2. Establish a connection to the receiver using either NovAtel Application Suite or another terminal program. This connection is used to send the commands in this procedure to the receiver.



For information about using NovAtel Application Suite, refer to docs.novatel.com/Tools/Content/ToolsSuite/Overview.htm.

3. Enable the Ethernet port on the receiver by entering:

```
ETHCONFIG ETHA AUTO AUTO AUTO AUTO
```

4. Assign the TCP/IP port number used for the connection by entering:

```
ICOMCONFIG ICOM1 TCP :2000
```

5. Assign the receiver IP address, subnet mask and default gateway by entering:

```
IPCONFIG ETHA STATIC 192.168.74.10 255.255.255.0 192.168.74.1
```



The command assigns the following values to the OEM7 receiver:

```
IP address = 192.168.74.10
Subnet mask = 255.255.255.0
Gateway = 192.168.74.1
```

These settings are examples only. The settings appropriate to your system may be different.

6. Save the new Ethernet settings by entering:

```
SAVEETHERNETDATA
```

7. Log the **IPCONFIG** command and confirm the TCP/IP configuration by entering:

```
LOG IPCONFIG ONCE
```

8. Configure your computer with a static IP address.
Refer to *Static IP address configuration—Windows 7* below.

6.2.2 Static IP address configuration—Windows 7

Follow these steps to set up a static IP address on a computer:

1. Click **Start | Control Panel**.
2. Click **Network and Sharing Centre**.
3. Click the **Local Area Connection** link.
The Local Area Connection Status window appears.
4. Click the **Properties** button.
The Local Area Connection Properties window appears.
5. Select **Internet Protocol Version 4 (TCP/IPv4)** and then click the **Properties** button.
The Internet Protocol Version 4 (TCP/IPv4) Properties window appears.
6. Click the **Use the Following IP Address** radio button, then enter the IP address, Subnet mask and Default gateway for the Ethernet port on the computer.



Ensure the Ethernet settings used for the computer are compatible with the Ethernet settings on the OEM7 receiver.

For example, the following settings are compatible with the OEM7 receiver settings used in *Static IP address configuration—receiver* on the previous page:

```
IP address = 192.168.74.11
Subnet mask = 255.255.255.0
Gateway = 192.168.74.1
```

7. Click the **OK** button.
The Local Area Connection Properties window appears.
8. Click the **Close** button.
The Local Area Connection Status window appears.
9. Click the **Close** button.
10. Proceed to *Confirming Ethernet setup* on the next page.

6.2.3 Confirming Ethernet setup

1. Connect the computer to the OEM7 receiver using an Ethernet cross-over cable.
See *Figure 38: Cross-over Ethernet cable configuration—OEM7 receiver* on page 134.
2. Connect to the receiver using NovAtel Application Suite or any third party terminal program that supports TCP/IP connections. Use the static IP address and port number assigned to the OEM7 receiver in *Static IP address configuration—receiver* on page 134.

6.3 Dynamic IP address configuration

Figure 39: Dynamic IP address configuration through a DHCP server—OEM7 receiver below shows the connections when an OEM7 receiver uses a dynamic IP address configuration.

Figure 39: Dynamic IP address configuration through a DHCP server—OEM7 receiver

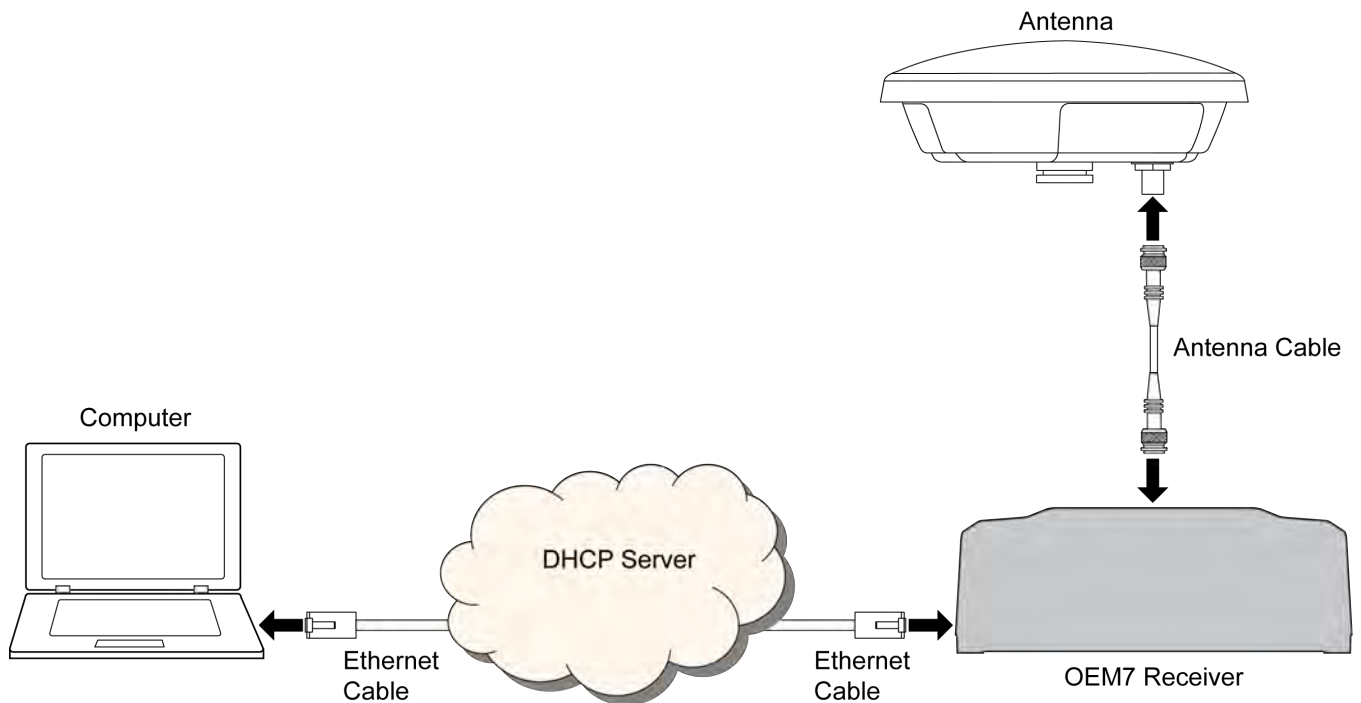

To set up a dynamic IP address configuration, follow these steps:

1. Connect a computer to the OEM7 receiver using a null modem serial cable or USB cable (model dependent).
2. Establish a connection to the receiver using either NovAtel Application Suite or another terminal program. This connection is used to send the commands in this procedure to the receiver.



For information about using NovAtel Application Suite, refer to docs.novatel.com/Tools/Content/ToolsSuite/Overview.htm.

3. Enable the Ethernet port by entering:

```
ETHCONFIG ETHA AUTO AUTO AUTO AUTO
```

4. Obtain the IP address assigned to the OEM7 receiver by the DHCP server.

```
LOG IPSTATUS ONCE
```



Make a note of the IP address returned with this log.

- Assign the TCP/IP port number by entering:

```
ICOMCONFIG ICOM1 TCP :2000
```

- Confirm the port number assigned to ICOM1 by entering:

```
LOG ICOMCONFIG ONCE
```

6.4 Base/rover configuration through Ethernet connectivity

You can use an Ethernet connection to provide communication between a base and rover receiver.

Figure 40: Base/rover Ethernet setup—OEM7 receiver below shows the connections when a base and rover OEM7 receiver are connected using Ethernet.

Figure 40: Base/rover Ethernet setup—OEM7 receiver

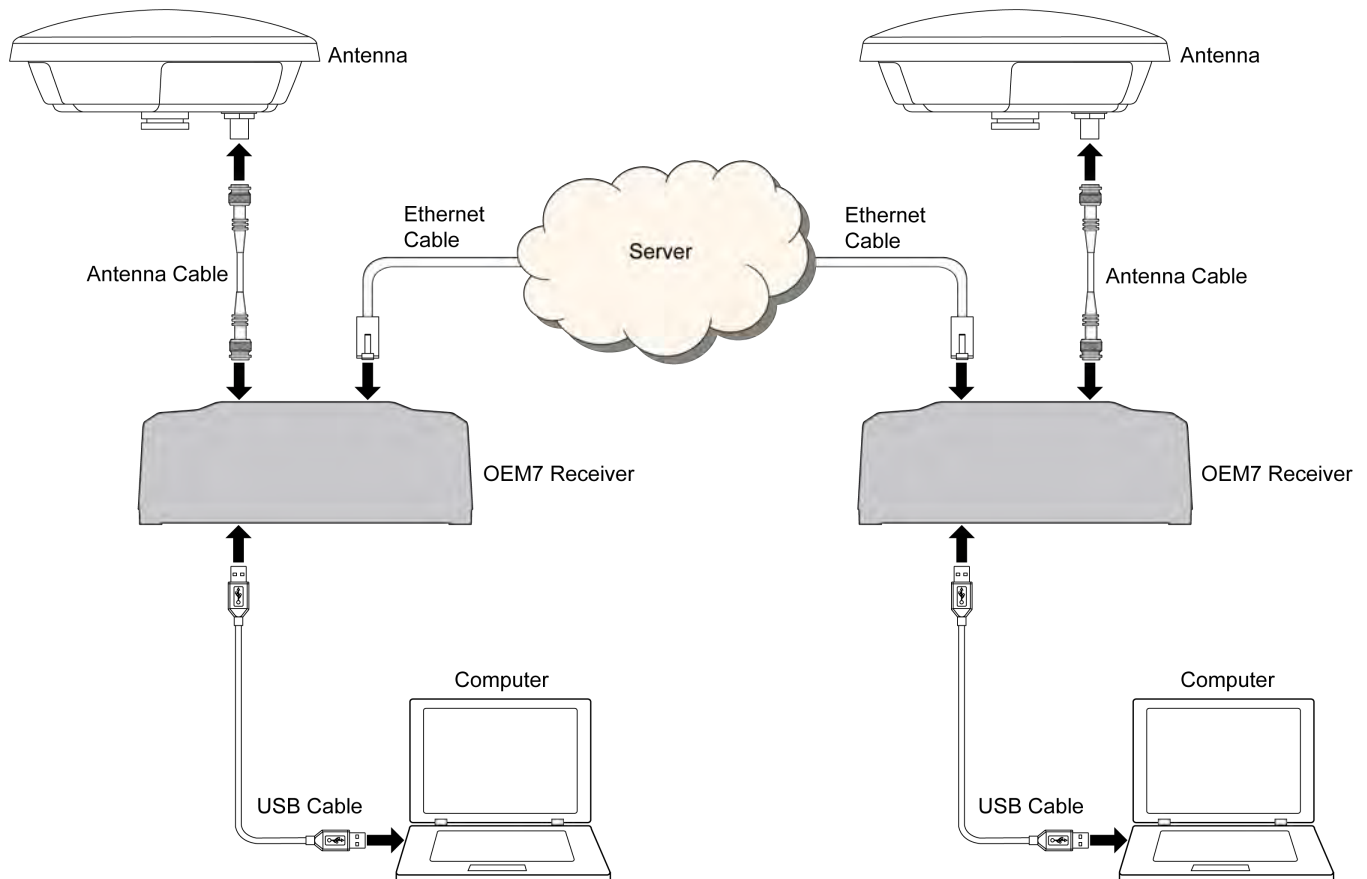

- Connect your computer to both OEM7 receivers using null modem serial cables or USB cables.
- Establish a connection to the receiver using either NovAtel Application Suite or another terminal program. This connection is used to send the commands in this procedure to the receivers.



For information about using NovAtel Application Suite, refer to docs.novatel.com/Tools/Content/ToolsSuite/Overview.htm.

3. Connect the power cables to both of the OEM7 receivers and apply power to the receivers.
4. Connect the Ethernet cables to the Ethernet ports on both OEM7 receivers.
5. Establish an Ethernet connection, either static or dynamic configurations. Refer to *Static IP address configuration* on page 133 or *Dynamic IP address configuration* on page 136 for more information.
6. Send the following commands to each receiver either through serial or USB ports:

Base:

```
FIX POSITION <lat> <long> <height>
INTERFACEMODE ICOM1 NONE RTCA off
LOG ICOM1 RTCAOBS2 ONTIME 1
LOG ICOM1 RTCAREF ONTIME 10
LOG ICOM1 RTCA1 ONTIME 5
SAVECONFIG
```

Rover:

```
ICOMCONFIG ICOM1 TCP <base ip address>:<base port #>
INTERFACEMODE ICOM1 RTCA NONE OFF
LOG BESTPOSA ONTIME 1 (optional)
SAVECONFIG
```

Use the **BESTPOS** log to confirm that the OEM7 rover is in RTK mode.

6.5 Large Ethernet port data throughput

For high data rate Ethernet logging using TCP/IP, disable Windows Delayed Ack Algorithm (DAA) for complete data logging. If you do not disable DAA, there will be data gaps due to the Windows Ethernet buffer.



If done incorrectly, changing the Windows Registry may impair the operation of the computer. Editing the Windows Registry is for advanced Microsoft Windows users only. NovAtel Inc. is not able to provide any technical support for any actions taken regarding information found in Microsoft's Knowledge Base.

Chapter 7 NTRIP configuration

An Ethernet capable OEM7 receiver can be configured as either an NTRIP server or an NTRIP client. An OEM7 receiver using a Wi-Fi connection can be configured as an NTRIP client. For more information about NovAtel's NTRIP, refer to novatel.com/products/firmware-options-pc-software/gnss-receiver-firmware-options/ntrip.

Figure 41: NTRIP system

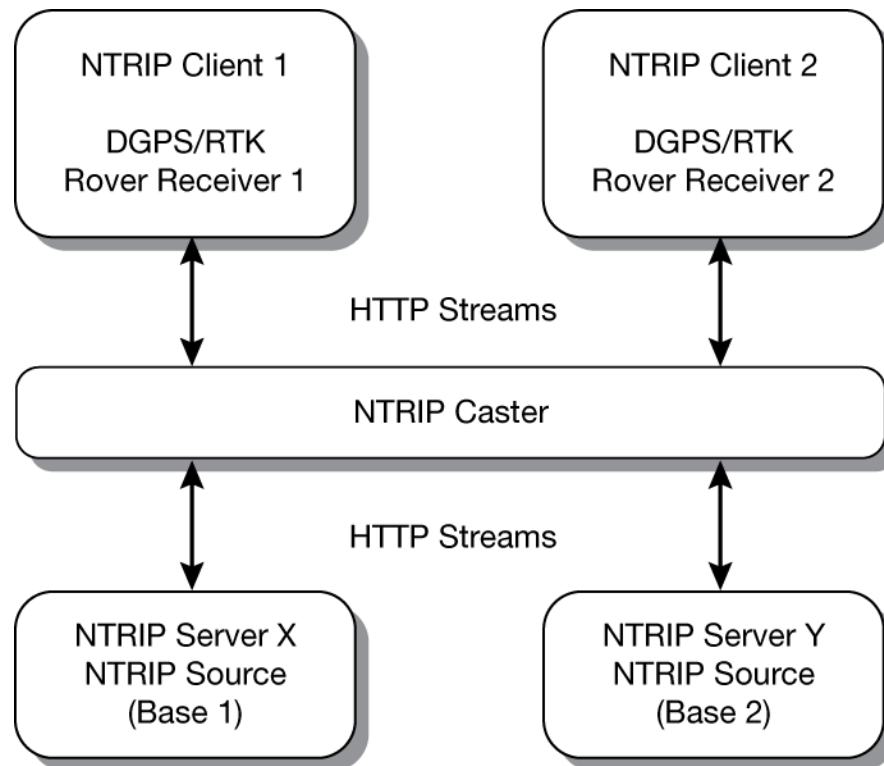

The NTRIP caster is an HTTP internet service that acts as a communication medium between NTRIP servers and NTRIP clients. The NTRIP caster is provided by third party sources. For a full list of NTRIP casters, refer to the following link: <http://www.rtcn-ntrip.org/home>.

7.1 NTRIP configuration over Ethernet

The following procedure describes how to configure a NovAtel base and a NovAtel rover through a third party NTRIP caster. This configuration is recommended for optimal RTK performance.

1. Establish a connection to the receiver using either NovAtel Application Suite or another terminal program. This connection is used to send the commands in this procedure to the receiver.



For information about using NovAtel Application Suite, refer to docs.novatel.com/Tools.

2. Connect the Ethernet cable to the Ethernet ports on both OEM7 receivers. For this setup, use a cross-over Ethernet cable.

3. Establish a static or dynamic Ethernet connection.
For information about creating the connection, refer to *Static IP address configuration* on page 133 or *Dynamic IP address configuration* on page 136.
4. Use the following commands to enable the base receiver as an NTRIP Server:

```
NTRIPCONFIG NCOM1 SERVER V2 <endpoint> <mountpoint> <username>
<password> ETHA
INTERFACEMODE NCOM1 NONE RTCA OFF
FIX POSITION <lat> <long> <height>
LOG NCOM1 RTCAOBS2 ONTIME 1
LOG NCOM1 RTCAREF ONTIME 10
LOG NCOM1 RTCA1 ONTIME 1
SAVECONFIG
```

5. Use the following commands to enable the rover receiver as an NTRIP Client:

```
ETHCONFIG ETHA AUTO AUTO AUTO AUTO
NTRIPCONFIG NCOM1 CLIENT V1 <endpoint> <mountpoint> <username>
<password > ETHA
```



If using a specific Network RTK system, certain National Marine Electronics Association (NMEA) strings are required to be sent from the rover back to the RTK network. For example, if connected to the VRS mount point, the rover is required to send its position to the network in a standard NMEA GGA message. This is achieved by issuing the following commands: LOG NCOMx GPGGA ONTIME 5, until data is received by the caster. For more information about Network RTK options and properties, refer to the application note [APN-041 Network RTK](#) and [APN-074: NTRIP on NovAtel OEM6/OEM7](#).

The following is an NTRIP Client configuration example without the use of a Network RTK system:

```
INTERFACEMODE NCOM1 RTCA NONE OFF
RTKSOURCE AUTO ANY
PSRDIFFSOURCE AUTO ANY
LOG BESTPOS ONTIME 1 (optional)
SAVECONFIG
```



Refer to the **NTRIPCONFIG** command in the [OEM7 Commands and Logs Reference Manual](#) for further command details.

Chapter 8 CAN bus

Controller Area Network (CAN) is a communication medium which allows for data exchange between devices using a multi-master serial data communication model. The main advantage of CAN is that multiple devices can communicate through two inexpensive wires that act as a BUS

The OEM7 receivers support the following CAN protocols:

- J1939 Transport and Extended Transport Protocol: used for corrections and NovAtel messages (both transmitting and receiving)
- NMEA2000: used for standard as well as NovAtel-proprietary messages (transmitting only)



CAN messages can also be read from or written to a CAN port using OEM7 commands and logs. This is typically implemented using the NovAtel API. For more information refer to Using Lua to Access I/O Devices Connected to the Receiver in the *OEM7 NovAtel API User Manual*. Note that if J1939 or NMEA protocol is enabled using the **CANCONFIG** command, the user CAN access commands will be rejected.

By default, CAN is disabled on OEM7 receivers. Critical CAN configuration parameters such as Parameter Group Numbers (PGNs), addresses and priorities are system-specific and must be explicitly configured.

The addresses and PGNs are typically allocated when the overall CAN bus topology is determined. A Node has a unique CAN J1939 NAME and address.



The CPT7 and CPT7700 have internal CAN transceivers, however they still require proper bus terminations.

Refer to *CPT7 connectors* on page 200 for pin-out information.

OEM7 receivers support the following NMEA2000 Parameter Group Messages (PGN) over the CAN bus:

- PGN 126992 System Time
- PGN 127250 Vessel Heading
- PGN 127251 Rate of Turn
- PGN 129025 GNSS Position Rapid Update
- PGN 129026 COG & SOG Rapid Update
- PGN 129027 Position Delta High Precision Rapid Update
- PGN 129028 Altitude Delta, Rapid Update
- PGN 129029 GNSS Position
- PGN 129551 GNSS Differential Signal

The following commands and logs are used for CAN configuration:

- **CANCONFIG** command: controls the CAN transceiver hardware and places the receiver *on bus* or *off bus*
- **J1939CONFIG** command: assigns the CAN J1939 NAME and address parameters to a Node

- **J1939STATUS** log: reports the status a Node on the J1939 CAN network, such as the claimed address
- **LOG CCOMx PGNabcd**: configures the NMEA2000 messages
- **CCOMCONFIG** command: configures the parameters used by the NovAtel command interface to interact with the CAN Bus.



CCOM ports with a lower port number have a higher transmission priority.



For information about these commands, see the [OEM7 Commands and Logs Reference Manual](#).



When the *NMEASOLUTIONSOURCE* is set to *ANTENNA*, the Vessel Heading and Rate of Turn are sourced from *RTKHeadingSolutionDP*, resulting in a delay between the time the rover receives the data and when the time-synchronized PGN messages are published associated to the *ALIGN* functionality requirement. For example, when the PGNs are logged at 10 Hz the delay may be up to 100ms and vary depending on the *ALIGN* corrections update rate set. Conversely, when the *NMEASOLUTIONSOURCE* is set to *INS*, the Vessel Heading and Rate of Turn are sourced from *NMEAazimuthSolutionDP*, eliminating any significant delay between data provision and publication.



Details for the PGN messages can be found in the NMEA2000 specification which can be purchased directly from the National Marine Electronics Association (www.nmea.org/).

8.1 Default configuration

After a FRESET, the receiver has the following CAN configuration:

- All CAN physical ports are disabled
- No J1939 addresses are claimed
- CCOM ports are configured for NMEA2000 messages only

Table 21: Default NAME

Parameter	Value
Address	0x1C
Industry Group	2
Device Class	0
Device Class Instance	0
Function	23
Function Instance	0
ECU Instance	0
Manufacturer Code	305

8.2 Configuring the CAN bus

To enable an OEM7 receiver to communicate over the CAN bus, configure CAN and place the receiver *on bus*, triggering a J1939 *Address Claim Procedure*.

1. Use the **J1939CONFIG** command to specify J1939 NAME and desired address.
This step is optional and only required if the default NAME parameters are to be changed.
2. Use the **CANCONFIG** command to place the receiver *on bus*.
3. Optionally, use the **J1939STATUS** log to monitor CAN status on the receiver.

8.2.1 Configuration notes

- The **J1939CONFIG** and **CANCONFIG** commands can be entered in any order. After the **CANCONFIG** command is used to place the receiver on the CAN bus, **J1939CONFIG** commands take effect immediately. Until then, J1939CONFIG can be entered many times to change the settings because they have not taken affect yet (the receiver is not yet on the bus).
- The J1939 Address claim procedure is executed if and only if both J1939CONFIG NODEx CANx and CANCONFIG CANx ON are entered.
- Use J1939STATUS log to determine the receiver's CAN status and the actual address claimed by a particular node.
- Once the receiver is "on bus", it must be taken "off-bus" using CANCONFIG for any further configuration changes using J1939CONFIG.
- The receiver is fully "on-bus" only once the J1939 address has been successfully claimed. This is reported as "CLAIMED" status by J1939STATUS log.
- No messages will be sent or received until the receiver is "online" and an address is claimed. Outgoing messages are not buffered; they are discarded until the receiver is online.

8.2.2 Example of enabling the CAN bus

1. LOG J1939STATUS ONCHANGED
2. J1939CONFIG NODE1 CAN1 <addresses>
3. CANCONFIG CAN1 ON 250K
4. SAVECONFIG
 - < J1939STATUS NODE1 DISABLED 0 0xFE
 - < J1939STATUS NODE1 CLAIMING 1 <address>
 - < J1939STATUS NODE1 CLAIMED <attempt count> <address>

8.2.3 Example of modifying the CAN bus parameters

1. LOG J1939STATUS ONCHANGED
2. CANCONFIG CAN1 OFF
3. J1939CONFIG NODE1 CAN1 <addresses>
4. CANCONFIG CAN1 ON
5. SAVECONFIG
 - < J1939STATUS NODE1 DISABLED 0 0xFE

```
< J1939STATUS NODE1 CLAIMING 1 <address>
< J1939STATUS NODE1 CLAIMED <attempt count> <address>
```

8.2.4 Example of detecting an address claim failure and reconfiguring

```
1. LOG J1939STATUS ONCHANGED
2. J1939CONFIG NODE1 CAN1 <addresses>
3. CANCONFIG CAN1 ON
   < J1939STATUS NODE1 DISABLED 0 0xFE
   < J1939STATUS NODE1 CLAIMING 1 <address>
   < J1939STATUS NODE1 FAILED <attempt count> 0xFE
4. CANCONFIG CAN1 OFF
   < J1939STATUS NODE1 DISABLED 0 0xFE
5. J1939CONFIG NODE1 CAN1 <addresses>
6. CANCONFIG CAN1 ON
   < J1939STATUS NODE1 CLAIMING 1 <address>
   < J1939STATUS NODE1 CLAIMED <attempt count> <address>
```

8.2.5 Address claim procedure

To become operational on the CAN bus, an OEM7 receiver must claim a J1939 address. The preferred address and a range of alternative addresses are specified using the **J1939CONFIG** command. When a configured receiver is placed *on bus*, it may make multiple attempts to claim an address. It may also have its address bumped by a higher priority device claiming the same address.

While the device is attempting to claim an address, the **J1939STATUS** log reports a status of *CLAIMING* and automatically tries to claim the next allowed address. Depending on the **J1939CONFIG** parameters, an address different from the **J1939CONFIG** *preferred address* may be claimed or the address claim procedure can fail entirely. If no addresses could be claimed, a *FAILED* status is reported and the receiver takes no further action. To recover from this failure, take the receiver *off bus* using the **CANCONFIG** command and change the CAN address configuration using the **J1939CONFIG** command.

The address can also be assigned using J1939 *Commanded Address* message sent by another ECU on the bus, such as a tester unit. The commanded address always overrides the address specified using **J1939CONFIG** command. When the *Commanded Address* is received, the receiver reports a status of *CLAIMING* followed by *CLAIMED*. Restarting CAN using the **J1939CONFIG** command or **CANCONFIG** command clears the commanded address; the Address Claim procedure will be executed again based on parameters specified in the **J1939CONFIG** command.

8.3 NMEA2000 logging

OEM7 receivers support both a subset of the standard NMEA2000 PGNs, as well as NovAtel proprietary PGNs.

All NMEA2000 logs are configured using the **LOG** command, where the COM port is a CAN port (CCOM). The CCOM port must be associated with a J1939 node using the **CCOMCONFIG** command. If only NMEA2000 logs are needed, **CCOMCONFIG** parameters other than J1939NODE may be ignored.

To enable NMEA2000 logs:

1. Configure the CAN bus. See *Configuring the CAN bus* on page 143.
2. Enable the CCOM port on the CAN bus node using the **CCOMCONFIG** command.
3. Enable the desired NMEA2000 logs.

NMEA2000 logs can be requested regardless of the on/off bus status of the receiver or the J1939 configuration. They are output if and only if the receiver is online.



The position for the **PGN129025**, **PGN129027** and **PGN129029** logs are reported in the user selected datum. See the **OUTPUTDATUM** command for more details.



When the solution type is INS (SPAN models), the DOPs in the PGN129029 message are calculated at a 1 Hz rate.

To determine if the receiver is providing an INS solution, check the **pos type** field in the **BESTPOS** log.

8.3.1 Example of NMEA2000 log configuration

1. CCOMCONFIG CCOM1 NODE1 NMEA2000
2. LOG CCOM1 PGN129025 ONTIME 0.5
3. LOG CCOM1 PGN129026 ONTIME 0.25
4. SAVECONFIG

8.4 Corrections over CAN

All NovAtel supported correction types are supported over CAN ports (CCOM).

To send or receive corrections:

1. Configure the CAN Bus. See *Configuring the CAN bus* on page 143.
2. Use the **CCOMCONFIG** command to configure the PGN and other CAN parameters used by the RTK corrections CAN messages.

PGN: Use the PGN designated for corrections.

Address:

- Use 0xFF to receive corrections from any CAN address and to broadcast corrections to all CAN nodes.
 - Use 0x00 to 0xFE to send corrections to or receive corrections from a specific CAN node.
3. Use the **INTERFACEMODE** command to configure the CCOM interface mode.
 - To transmit corrections, use the desired INTERFACEMODE, e.g. RTCMV3
 - To receive corrections, it is recommended to use INTERFACEMODE AUTO.



Corrections configuration (**CANCONFIG** and **INTERFACEMODE**) for a particular CCOM port do not affect its NMEA2000 configuration. NMEA2000 logs coexist with correction messages, both incoming and outgoing.

8.4.1 Example for receiving corrections from any source

1. CCOMCONFIG CCOM2 NODE1 J1939 61184 6 0xFF
2. INTERFACEMODE CCOM2 AUTO NONE OFF

8.4.2 Example for transmitting corrections to 0x1C node

1. CCOMCONFIG CCOM2 NODE1 J1939 61184 6 0x1c
2. INTERFACEMODE CCOM2 NONE RTCMV3 OFF

8.5 NovAtel messages over CAN

Standard NovAtel messages (commands, logs, responses) can be sent and received on the CAN Bus using CAN ports (CCOM). To reduce CAN Bus loading, NovAtel messages are sent using NovAtel standard binary format over J1939 (default).

The CCOM port requires special configuration and has the following limitations:

- A single CCOM port cannot be used for both Binary and ASCII / NovAtel ASCII messages.
- A single CCOM port cannot be used for both Binary messages and corrections.
- If the CCOM port is configured as *NOVATEL*, all input is interpreted as NovAtel ASCII or Abbreviated ASCII. Unlike other COM ports, the receiver will not distinguish between ASCII and binary input.
- To use CAN NOVATELBINARY, the CCOM port must be placed into NOVATELBINARY using the **INTERFACEMODE** command.



It is recommended to use one dedicated CCOM port for NovAtel messages and another dedicated CCOM port for corrections.



NovAtel UI configuration does not affect NMEA2000. Any CCOM port can be used for NMEA2000 logs irrespective of CCOMCONFIG settings.

To configure NovAtel User Interface over CAN:

1. Configure the CAN Bus. See *Configuring the CAN bus* on page 143.
2. Use the **CCOMCONFIG** command to configure the PGN and other CAN parameters.
3. Use the **INTERFACEMODE** command to configure the CCOM port for **NOVATELBINARY**.

Example: Configuring CCOM2 for NovAtel messages:

1. CCOMCONFIG CCOM2 NODE1 J1939 1234 6 0x1C
2. INTERFACEMODE CCOM2 NOVATELBINARY NOVATELBINARY OFF

8.6 Configuring OEM7 receivers to use OEM6 CAN settings

CAN Bus functionality has been enhanced on OEM7 receivers. To accommodate the enhancements in functionality and flexibility, several new commands and logs have been added. Also, the **SETCANNAME** command has been removed and the **CANCONFIG** command has been modified.

The following sections describes how to configure CAN on OEM7 receivers to operate like OEM6 receivers.

8.6.1 Configuration on OEM6

On OEM6 receivers, the **SETCANNAME** command, with minimal parameters, could be used to configure CAN.

```
SETCANNAME 305
```

Once entered, a limited address claim procedure would take place and NMEA2000 logs would be generated automatically at a fixed logging rate and fixed CAN port bit rate.

8.6.2 Configuration on OEM7

To configure an OEM7 receiver to log the same commands and use the same logging rate and CAN port bit rate, enter the following commands:

```
CCOMCONFIG CCOM1 NODE1 NMEA2000
CANCONFIG CAN1 ON 250K
LOG CCOM1 PGN129025 ONTIME 0.1
LOG CCOM1 PGN129026 ONTIME 0.1
LOG CCOM1 PGN129027 ONTIME 0.1
LOG CCOM1 PGN129029 ONTIME 1.0
SAVECONFIG
```

On OEM7 receivers, nothing is automatically logged when CAN is enabled. Regular log requests must be made for each log required.

A full address claim procedure with default values is initiated with the **CANCONFIG ON** command. The J1939CONFIG command can be used to modify the default address claim parameters including the ManufacturingCode (set to 603 in the SETCANNAME example above, now defaults to 305 in the new J1939CONFIG) but it's not necessary.

Chapter 9 Built-In Status Tests

The Built-In Status Test monitors system performance and status to ensure the receiver is operating within specifications. The test detects an exceptional condition and informs the user through one or more indicators. The receiver status system is used to configure and monitor the indicators:

1. Receiver status word (included in the header of every message)
2. RXSTATUSEVENT log
3. RXSTATUS log

When an unusual and non-fatal event occurs (for example, there is no valid position solution), a bit is set in the receiver status word. Receiver operation continues normally. When the event ends (for example, when there is a valid position solution), the bit in the receiver status word is cleared.

When a fatal event occurs (for example, a receiver hardware failure), a bit is set in the receiver error word, part of the **RXSTATUS** log, to indicate the cause of the problem. Bit 0 is set in the receiver status word to show that an error occurred. An **RXSTATUSEVENT** log is generated on all ports to show the cause of the error. Receiver tracking is disabled but command and log processing continues to allow error diagnosis. Even if the source of the error is corrected, the receiver must be reset to resume normal operation.

These two scenarios describe factory default behaviour. These behaviours can be customized to better suit an individual application. RXSTATUSEVENT logs can be disabled completely with the **UNLOG** command. RXSTATUSEVENT logs can be generated when a receiver status bit is set or cleared with the **STATUSCONFIG SET** and **STATUSCONFIG CLEAR** commands. Bits in the receiver status word can also be promoted to act like error bits with the **STATUSCONFIG PRIORITY** command.

9.1 Receiver status word

The receiver status word indicates the current status of the receiver. This word is found in the header of all logs and in the **RXSTATUS** log. In addition, the receiver status word is configurable.

The importance of the status bits can be determined with priority masks. For receiver status, setting a bit in the priority mask causes the condition to trigger an error. The error causes the receiver to idle all channels, turn off the antenna and disable the RF hardware, just like it would if a bit in the receiver error word is set. Setting a bit in an Auxiliary Status priority mask causes the condition to set the bit in the receiver status that corresponds to the auxiliary status.

Use the **STATUSCONFIG** command to configure the various status mask fields in the **RXSTATUS** log. Use the masks to specify whether various status fields generate errors or event messages when set or cleared.

Refer to the **RXSTATUS** log, **RXSTATUSEVENT** log and **STATUSCONFIG** command in the [OEM7 Commands and Logs Reference Manual](#) for more detailed descriptions of these messages.

9.2 RXSTATUSEVENT log

The **RXSTATUSEVENT** log is used to output event messages, as indicated in the **RXSTATUS** log.

On start up, the OEM7 receiver is set to log **RXSTATUSEVENTA ONNEW** on all ports. You can remove this message using the **UNLOG** command.

Refer to the **RXSTATUSEVENT** log in the [OEM7 Commands and Logs Reference Manual](#) for log and command details for a more detailed description of this log.

9.3 RXSTATUS log

The Receiver Status log (RXSTATUS) provides system status and configuration information in a series of hexadecimal words.

9.3.1 Status word

The status word is the third field after the header, as shown in the example in *Figure 42: Location of receiver status word* below.

Figure 42: Location of receiver status word

```
<RXSTATUS COM1 0 92.0 UNKNOWN 0 154.604 005c0020 643c 1899
< 00000022 5
< 005c0020 00000000 00000000 00000000
< 00000087 00000008 00000000 00000000
< 00000000 00000000 00000000 00000000
< 00000000 00000000 00000000 00000000
< 00000000 00000000 00000000 00000000
```

Receiver
Status
Word

Each bit in the status word indicates the status of a specific receiver condition or function. If the status word is 00000000, the receiver is operating normally. The numbering of the bits is shown in *Figure 43: Reading the bits in the receiver status word* below.

Figure 43: Reading the bits in the receiver status word

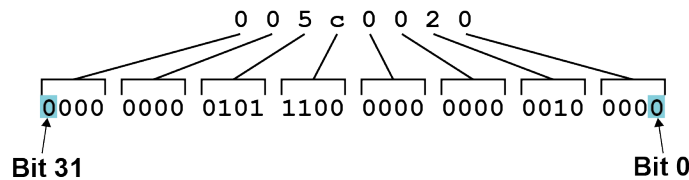

If the receiver status word indicates a problem, see *Examining the RXSTATUS log* on page 174.

9.3.2 Error word

The error field contains a 32-bit word. Each bit in the word is used to indicate an error condition. Error conditions may result in damage to the hardware or erroneous data, so the receiver is put into an error state. If any bit in the error word is set, the receiver broadcasts the **RXSTATUSEVENT** log on all ports (unless the user has unlogged it), idles all channels, turns the antenna off and disables the RF hardware. To override the error state, reset the receiver.

The receiver can be configured to generate event messages triggered by status conditions. Receiver Error words automatically generate event messages. These event messages are output in the **RXSTATUSEVENT** log (see also *Set and clear mask for all status code arrays* on page 151).

The error word is the first field after the log header in the **RXSTATUS** log, as shown in the example in *Figure 44: Location of receiver error word* on the next page.

Figure 44: Location of receiver error word

```

<RXSTATUS COM1 0 92.0 UNKNOWN 0 154.604 005c0020 643c 1899
< 00000022 5
< 005c0020 00000000 00000000 00000000
< 00000087 00000008 00000000 00000000
< 00000000 00000000 00000000 00000000
< 00000000 00000000 00000000 00000000
< 00000000 00000000 00000000 00000000
Receiver
Error
Word
    
```

Figure 45: Reading the bits in the receiver error word below shows an example of a receiver error word.

Figure 45: Reading the bits in the receiver error word

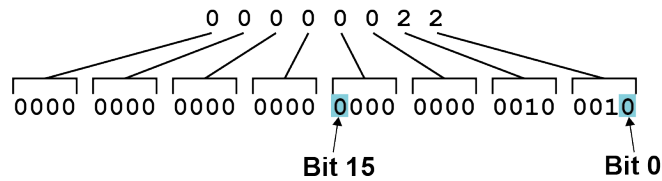

Refer to the **RXSTATUS** log and **RXSTATUSEVENT** log in the [OEM7 Commands and Logs Reference Manual](#) for more detailed log descriptions. If the receiver error word indicates an error, refer to *Examining the RXSTATUS log* on page 174.

9.3.3 Status code arrays

There are currently 5 status code arrays:

- receiver status word
- auxiliary 1 status
- auxiliary 2 status
- auxiliary 3 status
- auxiliary 4 status

Each status code array consists of four 32-bit words (the status word, a priority mask, a set mask and a clear mask). The status word is similar to the error word, with each of the 32 bits indicating a condition. The priority mask words are used to modify the behaviour caused by a change in one of the bits in the associated status words. Each bit, in any mask, operates on the bit in the same position in the status word. For example, setting bit 3 in the priority mask changes the priority of bit 3 in the status word.

Figure 46: Status code arrays

```

<RXSTATUS COM1 0 92.0 UNKNOWN 0 154.604 005c0020 643c 1899
<      00000022 5
<      005c0020 00000000 00000000 00000000 ← Receiver Status
<      00000087 00000008 00000000 00000000 ← Auxiliary 1 Status
<      00000000 00000000 00000000 00000000 ← Auxiliary 2 Status
<      00000000 00000000 00000000 00000000 ← Auxiliary 3 Status
<      00000000 00000000 00000000 00000000 ← Auxiliary 4 Status

```

↑
↑
↑
↑

Status **Priority** **Set** **Clear**
Word **Mask** **Mask** **Mask**

9.3.4 Receiver status code

The receiver status word is included in the header of all logs. It has 32 bits that indicate certain receiver conditions. If any of these conditions occur, a bit in the status word is set. Unlike the error word bits, the receiver continues to operate, unless the priority mask for the bit has been set. The priority mask bit changes the bit in the receiver status word into an error bit. Anything that results from an error bit becoming active also occurs if a receiver status and its associated priority mask bits are set.

9.3.5 Auxiliary status codes

The auxiliary status codes are only in the **RXSTATUS** log. The four arrays that represent the auxiliary status codes indicate the receiver state for information purposes only. The events represented by these bits typically do not cause receiver performance degradation. The priority mask for the auxiliary codes does not put the receiver into an error state. Setting a bit in the auxiliary priority mask results in the corresponding bit in the receiver status code to be set if any masked auxiliary bit is set. Bit 31 of the receiver status word indicates the condition of all masked bits in the auxiliary 1 status word. Likewise, bit 30 of the receiver status word corresponds to the auxiliary 2 status word and bit 29 to the auxiliary 3 status word.

Refer also to the **RXSTATUS** log in the [OEM7 Commands and Logs Reference Manual](#) for a more detailed description.

9.3.6 Set and clear mask for all status code arrays

The other two mask words in the status code arrays operate on the associated status word in the same way. These mask words are used to configure the bits in the status word that result in a **RXSTATUSEVENT** log broadcast. The set mask is used to turn logging on temporarily while the bit changes from the 0 to 1 state. The clear mask is used to turn logging on temporarily while the bit changes from a 1 to a 0 state. Note the error word does not have any associated mask words. Any bit set in the error word results in a **RXSTATUSEVENT** log broadcast (unless unlogged).

Refer also to the **RXSTATUS** log in the [OEM7 Commands and Logs Reference Manual](#) for a more detailed description.

Chapter 10 Receiver Features: Authorization and Subscriptions

OEM7 optional software features are enabled on a termed or permanent basis through the purchase of subscriptions or software model upgrades. All features are available through subscription and most as a software model upgrade. Receiver features include:

- GNSS signals and constellations tracked
- Positioning corrections types enabled: SBAS, PPP, RTK, RTK Assist, ALIGN
- PPP Corrections services enabled: TerraStar, Oceanix, Apex, Ultra, Standard
- Inertial Navigation type and class (SPAN)
- LUA scripting support
- Position report rates, measurements and RTK corrections output
- Dual Antenna Heading, Relative Positioning, Interference Toolkit, RoDAR and other product specific features.

Contact NovAtel sales (sales.nov.ap@hexagon.com, 1-800-NOVATEL), use the NovAtel eStore or integrate the NovAtel eCommerce Machine to Machine (M2M) API to purchase subscriptions and software model options.

The purchased service authorization is dispatched immediately to the receiver over L-band satellite or IP connection or can be provided on demand with an IP request to the M2M interface. You can subscribe to multiple features simultaneously and the ecommerce system ensures that service products include all features and function levels needed for a service to function effectively. NovAtel offers bundles of services including SmartNet RTK Corrections and Waypoint post processing software along with the associated receiver features.

You can choose the duration and start date of a subscription and then renew seamlessly either manually or automatically. Different services can start and end at different times and compatible services can overlap. During a service period the active model will be the union of the last requested permanent model and all of the subscribed features. The receiver will display a schedule of current, future and recently past service periods and transitions between them automatically. You can trial a new service or upgrade a service temporarily or permanently at any time. You can purchase a subscription for one receiver for the duration (fixed) or a pool of seats that can be assigned to different receivers as needed over the duration (flex). An enterprise agreement can allow a whole group of receivers continuous baseline service and the option to upgrade with other subscriptions. You can easily purchase and manage subscriptions for many receivers in bulk with streamlined assignment and coordinated renewal. NovAtel offers a simple web-based application (SMUI) to manage your subscriptions.

Services requiring external corrections, such as TerraStar, Oceanix, Apex and SmartNet require a subscription, but other receiver features can also be purchased as a permanent software model upgrade. That model upgrade is dispatched to the receiver over L-band, IP or M2M in the same way as a subscription. The receiver also supports the legacy auth-code method of delivering software model upgrades.

10.1 Serial Number, Hardware Version, Software Model, Firmware Version

The **VERSION** log provides the active software model, product serial number (PSN), hardware model and version and the currently installed firmware version. All of these are needed for most support calls and subscription purchases.

Enter **LOG VERSION** and select the line beginning with *GPSCARD*.

Example:

Software Model	Receiver PSN	Hardware Version	Firmware Version
GPSCARD	"FFNRNNCBES1"	"BMHR17090005E"	"OEM7700-1.00"
			"OM7CR0810RN0000"
			"OM7BR0001RBG000"
			"2021/Dec/06"
			"11:16:48"

The software model is an up to 15-character ASCII string which indicates the currently authorized receiver features. **VERSION** shows the model currently active on the receiver. The active model may be provided by a current subscription service period or by the selected permanent model as indicated in the **DISPATCHSCHEDULE** log. Other models may be available for selection with the **MODEL** command. These models are shown in the **VALIDMODELS** log.

The PSN in this line is the serial number of the OEM7 receiver card. If your receiver is in an enclosure or SMART antenna, that enclosure may have a separate PSN which is shown in the line starting with ENCLOSURE and is printed on the enclosure label. Both the card PSN and the enclosure PSN will work for support calls or subscription purchases.

The hardware version string identifies both the OEM7 card type and the revision of the hardware. An enclosure will also have a hardware version and revision in the ENCLOSURE line.

The firmware version string provides many details, but the key values are the 7 in 3rd character, for OEM7, and characters 6-9, which are the feature and maintenance revisions. These are often written in the form 7.FF.MM (eg 7.08.10) in documentation. The latest versions are available at the NovAtel web site (novatel.com/support/support-materials/firmware-download). See **Firmware updates** for instructions.

10.2 Authorization code

An authorization code, commonly known as an auth-code, is the legacy method to deliver permanent software model upgrades to an OEM7 receiver. See *Receiver Features: Authorization and Subscriptions* on the previous page for other delivery methods. Receiver features purchased with the hardware are shipped as a software model already installed on the hardware. These can be upgraded at any time. Software model upgrades can be purchased through the NovAtel eStore, NovAtel or Veripos dealers, NovAtel M2M interface or by contacting novatel.com/support.

Auth-codes and software model upgrade purchases are specific to a particular receiver card as identified by its Product Serial Number (PSN). Availability of certain receiver features depends on the receiver hardware model and the installed firmware version. You may have to upgrade to the latest firmware version to enable certain receiver features. Obtain these as described in *Serial Number, Hardware Version, Software Model, Firmware Version* on the previous page before purchasing a software model upgrade. If you choose to use the auth-code delivery method, you will be given an auth-code in the form:

```
XXXXXX,XXXXXX,XXXXXX,XXXXXX,XXXXXX,MODEL
```

For example:

```
7WBMBK,887CB6,K5J3FH,5DF5P2,42PW8G,DDNPYNTMN
```

The model name may be up to 15 ASCII characters. The auth-code is case insensitive. Apply this code to the receiver to upgrade to this model as outlined in *Applying a Software Model with an auth-code* below.

If the model requires a new firmware version, refer to *Firmware updates* on page 156.

Firmware images may also have auth-codes embedded within them. The models provided by such firmware images will be valid only on receivers with certain PSNs and Hardware Models.

10.2.1 Applying a Software Model with an auth-code

A software model enables receiver features and can be delivered to the receiver through dispatch messages (see *Receiver Features: Authorization and Subscriptions* on the previous page) or an authorization code (auth-code).

An auth-code can be entered using NovAtel Application Suite, Manage Web or the command line interface.

Entering an auth-code using NovAtel Application Suite

1. Obtain the new auth-code from NovAtel Sales or your local NovAtel dealer.
2. Connect a computer to the receiver using a serial (COM) cable, USB cable or Ethernet connection.
3. Start NovAtel Application Suite on the computer.
4. Use NovAtel Application Suite to connect to the receiver.

For information about using NovAtel Application Suite, refer to docs.novatel.com/Tools/Content/ToolsSuite/Overview.htm.

5. Click the **Device** menu and select **Details**.
The **Details** window appears.
6. On the *Authorizations* tile, enter the new auth-code in the **Apply New Auth Code** box.
7. Click the **Apply** button to save the changes to the receiver.
The receiver will restart when a new auth-code is applied.

Entering an auth-code using Manage Web

1. Obtain the new auth-code from NovAtel Sales or your local NovAtel dealer.
2. Connect the receiver to a computer using an Ethernet connection.
For information about configuring the receiver Ethernet interface, see *Ethernet configuration* on page 133. Note the receiver IP address.
3. Open a web browser and enter the receiver IP address in the address (URL) bar of the browser.
The Manage Web Home page appears.
4. Click the Menu icon and select **Details**.
The **Details** window appears.
5. Open the **Authorizations** tile.
6. Enter the new auth-code in the **Apply New Auth Code** box.
7. Click the **Apply** button to save the changes to the receiver.
The receiver will restart when a new auth-code is applied.

Entering an auth-code using the Command Line

The **AUTH** command is used to enter an auth-code. The upgrade can be performed directly through the NovAtel Application Suite command line or from any other communications program.

1. Power up the receiver and establish communications.
2. Issue the **LOG VERSION** command to verify the current model, firmware version and serial number (refer to *Serial Number, Hardware Version, Software Model, Firmware Version* on page 152 for instructions on obtaining).
3. Issue the **AUTH ADD** command, followed by the auth-code (refer to *Authorization code* on the previous page for details on obtaining any auth-code). The syntax is as follows:

```
auth add <auth-code>
```

where **auth add** is a command that enables model upgrades and auth-code is the upgrade authorization code, expressed as follows:

```
XXXXXX,XXXXXX,XXXXXX,XXXXXX,XXXXXX,MODEL
```

Example:

```
auth add 7WBMBK,887CB6,K5J3FH,5DF5P2,42PW8G,DDNPYNTMN
```

When the **AUTH** command is executed, the receiver reboots.

If communicating using NovAtel Application Suite, the connection must be closed and reopened using the *Devices* window.

Issuing the **LOG VERSION** command confirms the new model has been installed, selected, and applied.

Chapter 11 NovAtel firmware

Download the most recent versions of the NovAtel firmware from the novatel.com/support/support-materials/firmware-download.

NovAtel firmware runs on NovAtel receivers. It provides the features and functionality available on the receiver.

11.1 Firmware updates

A local NovAtel dealer can provide all the information needed to update a receiver. Refer to novatel.com/contactus/sales-offices for contact information or contact sales.nov.ap@hexagon.com or support.novatel@hexagon.com directly.

11.1.1 Firmware updates

Firmware updates are firmware releases that include fixes and enhancements to receiver functionality. Firmware updates are released on the NovAtel web site as they become available. Firmware updates can be performed using NovAtel Application Suite, Manage Web, SoftLoad commands or a custom loader application. Contact NovAtel Customer Support (support.novatel@hexagon.com) for details on custom loader requirements.

11.1.2 Firmware downgrades

Receiver firmware can be rolled back to a previous version by downloading the previous firmware version onto the receiver. However before downgrading the firmware, perform a factory reset of the receiver using the **FRESET** command to ensure all saved commands have been erased.



A factory reset using the FRESET command is required before downgrading firmware. Not performing a factory reset could cause unpredictable behaviour.

11.2 Downloading firmware files

To proceed with an update or possibly an upgrade, obtain the latest version of firmware by downloading the firmware file for your product from novatel.com/support/support-materials/firmware-download.



If the receiver is an H-model, do not use the firmware available from the web site. Contact *Customer Support* on page 16 to obtain the correct firmware.

11.2.1 Format of firmware files

All of the firmware available on the downloads website are packaged in .zip files with the following name:

- <receiver type>_Firmware_7.xx.xx.zip

For convenience, unzip the update file to a GNSS sub-directory (for example, C:\GNSS\LOADER). If the firmware update file is password protected, NovAtel Customer Support provides the required password.

The zip archive includes the following files:

x..x.shex	Firmware version upgrade file, where x..x defines the product name and release (e.g., OM7MR09023RN0000.shex)
HowTo_7XXXX_YYY.pdf	Instructions on how to install the firmware 7XXXX identifies the firmware version and YYY identifies the type of receiver
NovAtel Software License Agreement.pdf	License agreement for the firmware
WhatsNew_7XXXX.pdf	Information on the changes made in the firmware since the last revision 7XXXX identifies the firmware version



NovAtel has an online video tutorial that explains firmware updating at: novatel.com/support/support-materials/novatel-video.

11.3 Updating the firmware using the WinLoad utility



The WinLoad utility is no longer provided with new firmware releases.

NovAtel recommends using NovAtel Application Suite or Manage Web to load new firmware onto the receiver.

WinLoad is a utility used to update or upgrade a receiver. To use WinLoad, the receiver must be connected to the computer running WinLoad using a serial port (COM port) connection.

If opening WinLoad for the first time, ensure the file and communications settings are correct.

11.3.1 Open a file to download

Select File | File Open. Navigate to the file to open (*Figure 47: WinLoad's Open Window* below).

Figure 47: WinLoad's Open Window

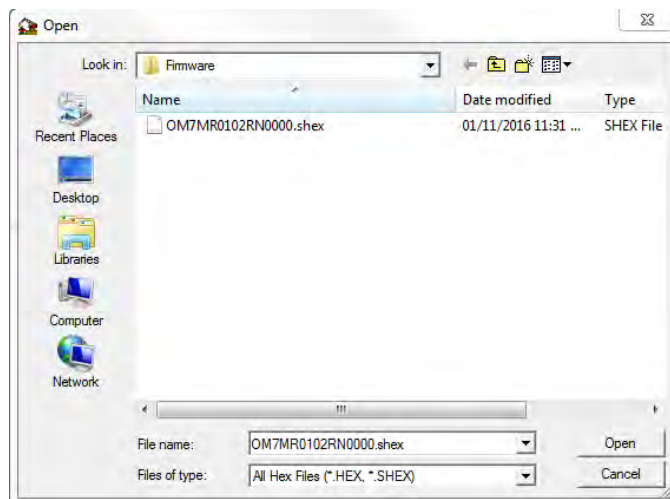

When a file is selected, the *filename* appears in the main WinLoad display area and in the title bar (*Figure 48: Open File in WinLoad* on the next page).

Figure 48: Open File in WinLoad

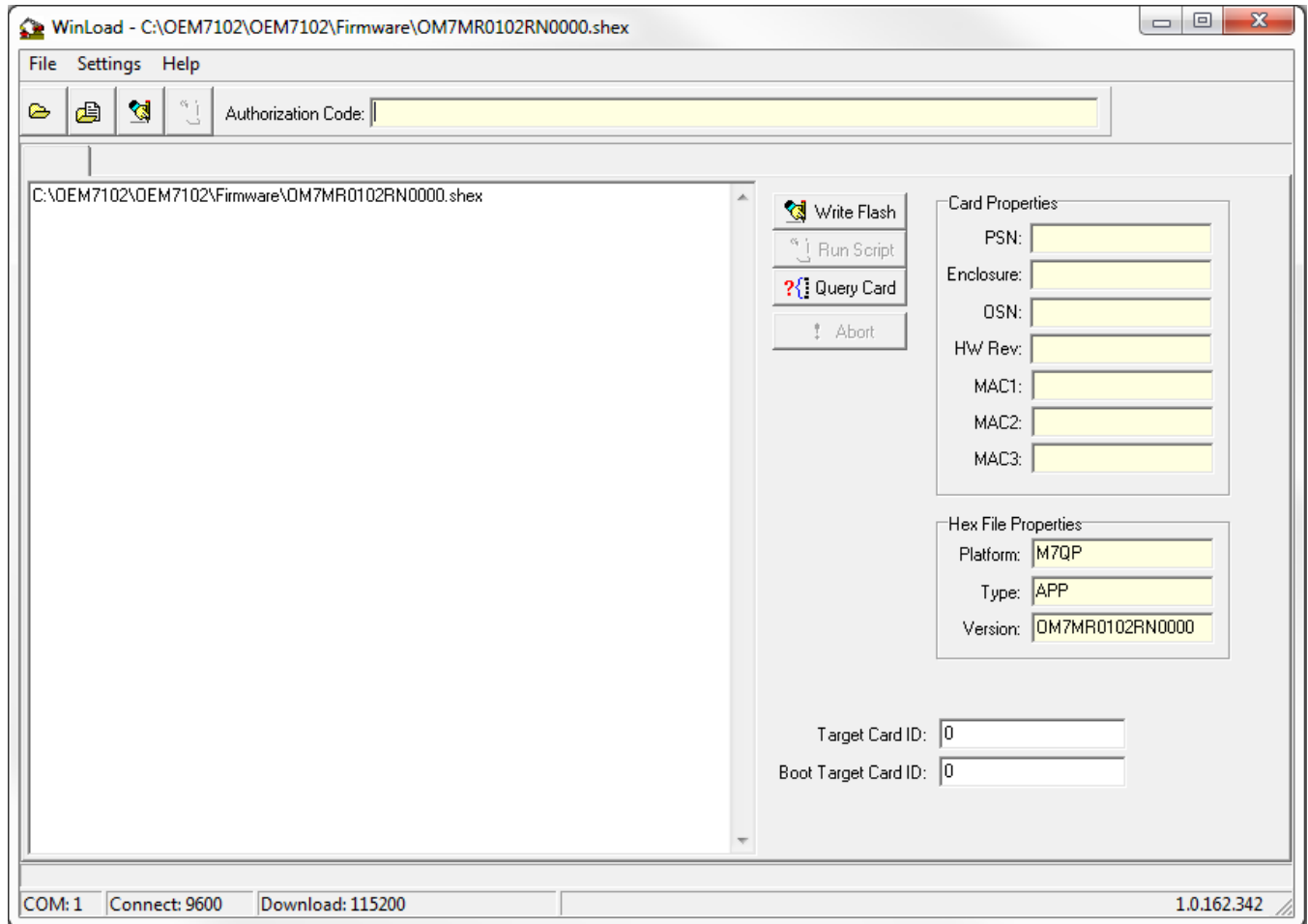

11.3.2 Communications settings

To set the communications port and baud rate, select Settings | COM Settings. Choose the computer port to use from the Com Port drop down list and the baud rate from the Download Baudrate drop down list. Set the baud rate as high as possible (the default of 115200 is preferred if a higher baud rate is not available).

Figure 49: COM Port Setup

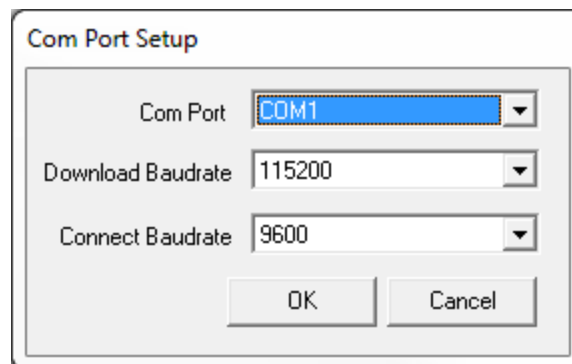

11.3.3 Downloading firmware

1. Select the file to download according to *Open a file to download* on page 157.
2. Ensure the file path and name are displayed in main display area (see *Figure 48: Open File in WinLoad* on the previous page).
3. Click **Write Flash** to download the firmware.
4. When **Searching for card** appears in the main display, power cycle the receiver.
5. If the Authorization Code window appears, enter the auth-code and click **OK**. See *Authorization code* on page 153 for further information about the Authorization Code.
6. The receiver finishes the download and then resets. The process is complete when **Done** appears in the main display area.
7. Close WinLoad.



If loading a firmware that is currently installed on a receiver (i.e. reloading the same version of firmware on a receiver), ensure the *Optimized Loading* option is unchecked in WinLoad under *Settings | Options | Optimized Loading*.

As well, if firmware loading fails with the error message "Desired SW already is on board", ensure the *Optimized Loading* option is unchecked.

11.4 Updating the firmware using NovAtel Application Suite

To use NovAtel Application Suite to update the receiver firmware, the receiver must be connected to the computer running NovAtel Application Suite using a serial (COM) port, USB port or Ethernet port.

To update the firmware on the receiver:

1. Obtain the new firmware file.

See *Downloading firmware files* on page 156 for information about obtaining the latest version of receiver firmware.



Copy the firmware file to the computer's local drive before uploading.

2. Connect a computer to the receiver using a serial (COM) cable, USB cable or Ethernet connection.
3. Start NovAtel Application Suite on the computer.
4. Use NovAtel Application Suite to connect to the receiver.
For information about using NovAtel Application Suite, refer to docs.novatel.com/Tools/Content/ToolsSuite/Overview.htm.
5. On the *Status and Configuration* window, click the **Device** menu and select **Update**.
The *Update* window appears.
6. Click the **Browse** button.
7. Navigate to the directory that contains the new firmware file and select the file.
8. Click the **Open** button.

The Update window appears with the name of the selected file in the Select File field.

9. Click the **Apply** button.

After the new software is loaded, the receiver will restart.

11.5 Updating the firmware using Manage Web

To use NovAtel Manage Web to update the receiver firmware, the receiver must be connected to the receiver using an Ethernet connection.

To update the firmware on the receiver:

1. Obtain the new firmware file.

See *Downloading firmware files* on page 156 for information about obtaining the latest version of receiver firmware.



Copy the firmware file to the device's local drive before uploading.

2. Connect the receiver to a computer using an Ethernet connection.
3. Open a web browser and enter the IP address assigned to the receiver.

The Manage Web Home page appears.

4. Click the Menu icon and select **Update**.
5. Click the **Select File** button
6. Navigate to the folder in which the new software to load is stored and select the software file.
7. Click the **Apply** button.

After the new software is loaded, the receiver will restart.

11.6 Updating using SoftLoad commands

Firmware can be updated on a running receiver using a process called SoftLoad. Any available communication ports on the receiver (COM, USB, ICOM) can be used. The SoftLoad process is made up of a set of commands and logs that are used to send new firmware data to a receiver and check the progress of the update.

Use SoftLoad if automated loading is desired or if the receiver does not have access to tools such as NovAtel Application Suite or Manage Web, to load firmware.

The receiver stops tracking GNSS satellites during the SoftLoad process. Do not attempt to SoftLoad when GNSS satellite tracking on the unit is required.

11.6.1 Implementing SoftLoad

To implement the SoftLoad process, you can either:

- Use SoftLoad Customer Support utilities:

You can use NovAtel developed utilities to upgrade firmware. This method is easier to implement than self-implementing Softload. For more information suitability and implementation, refer to *Use SoftLoad Customer Support utilities* on the next page.

- Self-Implement the SoftLoad process:

You can develop the process on your own, including processing the S-Records, converting them to NovAtel format commands, and Sending Firmware Data. This method is suitable for users with deeply embedded receivers and is more difficult to implement and integrate. For more information on suitability and implementation, refer to *Self-implement the SoftLoad process* on page 166.

11.6.2 Use SoftLoad Customer Support utilities

This method is appropriate for customers that want to upgrade firmware without the complexity of self-implementing the SoftLoad process, but cannot use NovAtel Application Suite or Manage Web to load firmware. This method requires at a minimum:

- The desired firmware build as an .shex file
- The utility – srec2softload_dev_20160603.exe
- The receiver must be able to connect to a terminal like RealTerm

Process for using Customer Support utilities

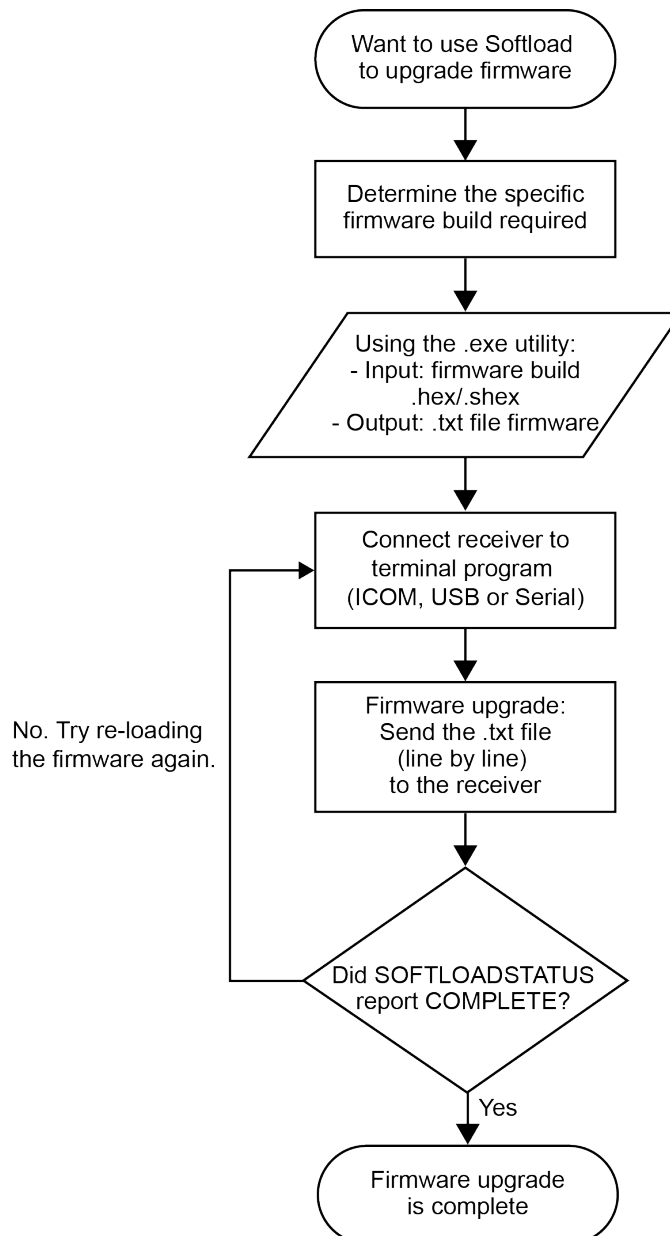

Using the srec2softload utility

1. Contact Customer Support at novatel.com/support and ask about the **srec2softload** utility.



At this step the Customer Support representative may assist in directly preparing the txt batch file for you. In this case, continue at *Sending firmware data* below.

2. In a new folder, load the srec2softload_dev_20160603.exe utility and the desired shex/hex firmware file
3. Create a blank text file (can name it as desired, e.g. "softload_OM7MR0703RN0000.txt"). This text file will be the output from the utility where the batch script will be converted and placed.
4. In that folder, open up a Powershell window and enter:

```
<softload utility name> <input shex/hex file> <output blank text file>
```

For example: `.\srec2softload_dev_20160603 .\OM7MR0703RN0000.shex .\softload_OM7MR0703RN0000.txt`

5. Press **Enter** and the output text file will be populated with the batch file. A confirmation message/response will appear.

Sending firmware data

It can take 30 minutes to 1 hour to complete sending the entire firmware to the receiver. RealTerm is preferred, but other terminal programs may be used (at user's discretion).

1. Download RealTerm from: sourceforge.net/projects/realterm/.
2. Open RealTerm, go to the Port tab.
3. Choose the COM port to be used (if using USB or Serial) along with the appropriate baud rate. If using Ethernet, type the IP address right where the Port dropdown menu is. Baud rate is not required to be specified if using Ethernet.



If using ICOM (Ethernet), ensure the Winsock option is set to Raw, otherwise the binary part of firmware will be encoded and produce CRC errors. This is not necessary if connecting via serial or USB.



If using ICOM (Ethernet), a connection will be verified by the [ICOM1] string showing up at the top.



If using serial or USB, screen will appear empty.

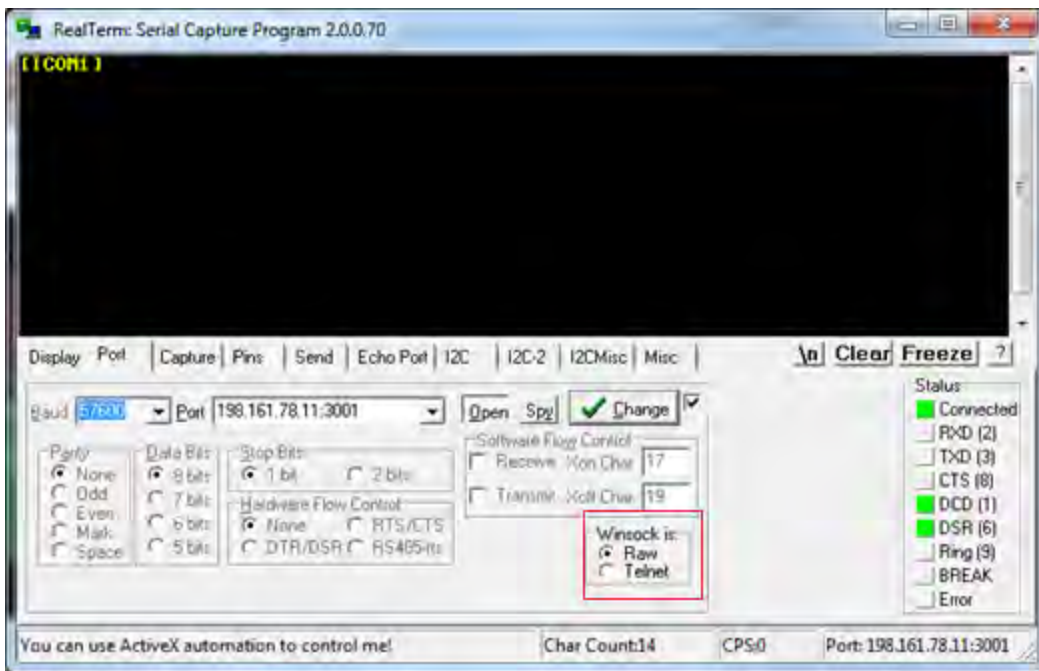

4. Go to the **Send** tab. Click on the ellipsis button to the right of the **Dump File to Port** drop down menu.

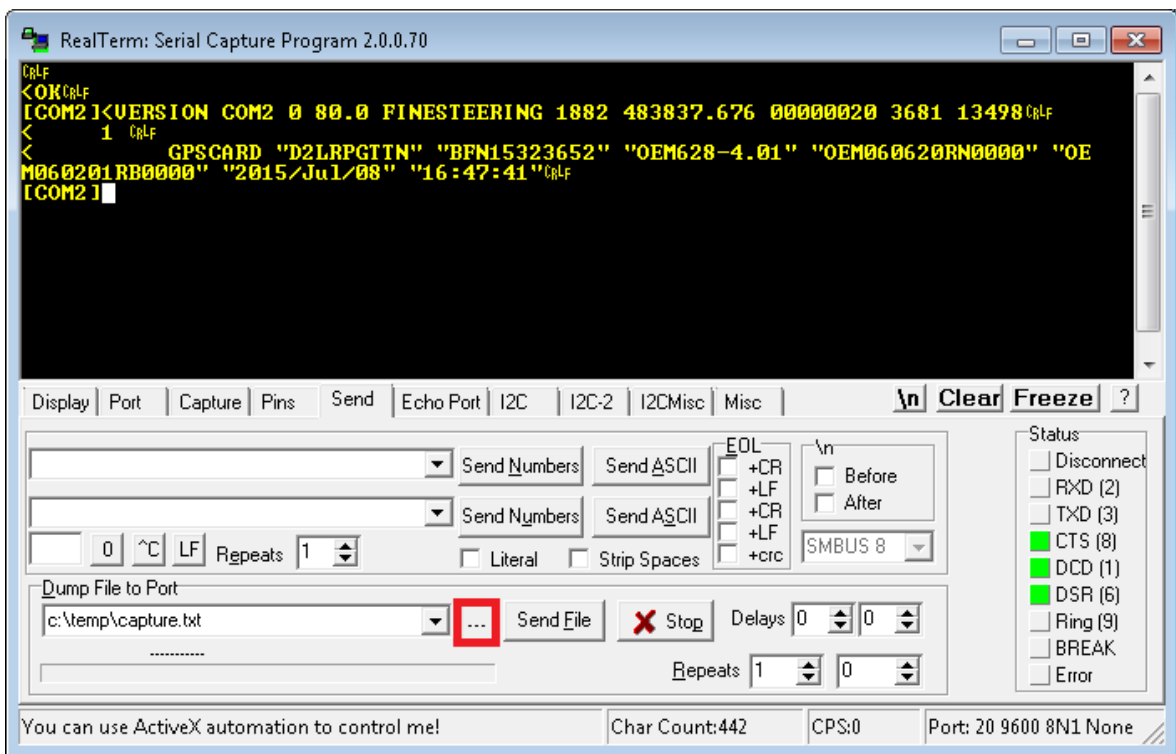

If connecting to receiver via serial or USB, ensure a delay of at least 20 msec is specified between each line. This is NOT necessary for ICOM connections; it will just cause the firmware to take longer to load. The option can be found in the Send tab of RealTerm.

- RealTerm will indicate when the entire file has been sent. Note the output at the end indicates SOFTLOAD completed without any issues.

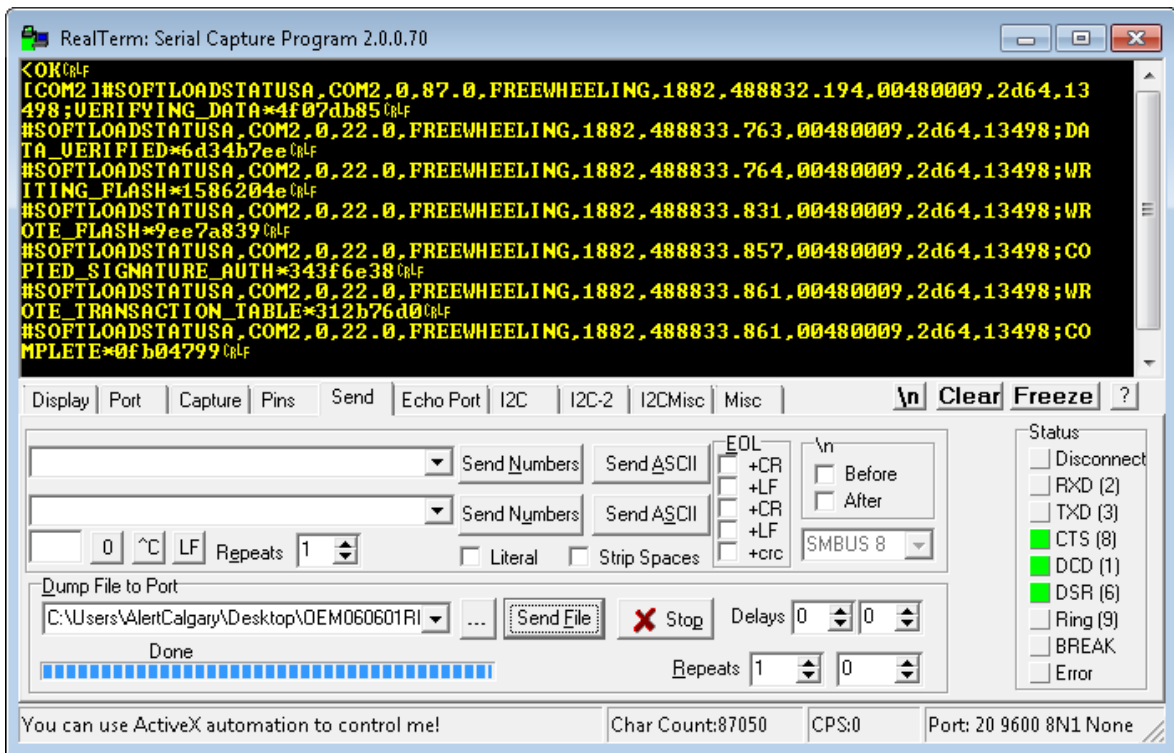

- Once SOFTLOADSTATUS has confirmed the process is COMPLETE, send the **RESET** command.
- Once the receiver has been reset, send the **LOG VERSION** command to confirm the desired firmware version has been installed.

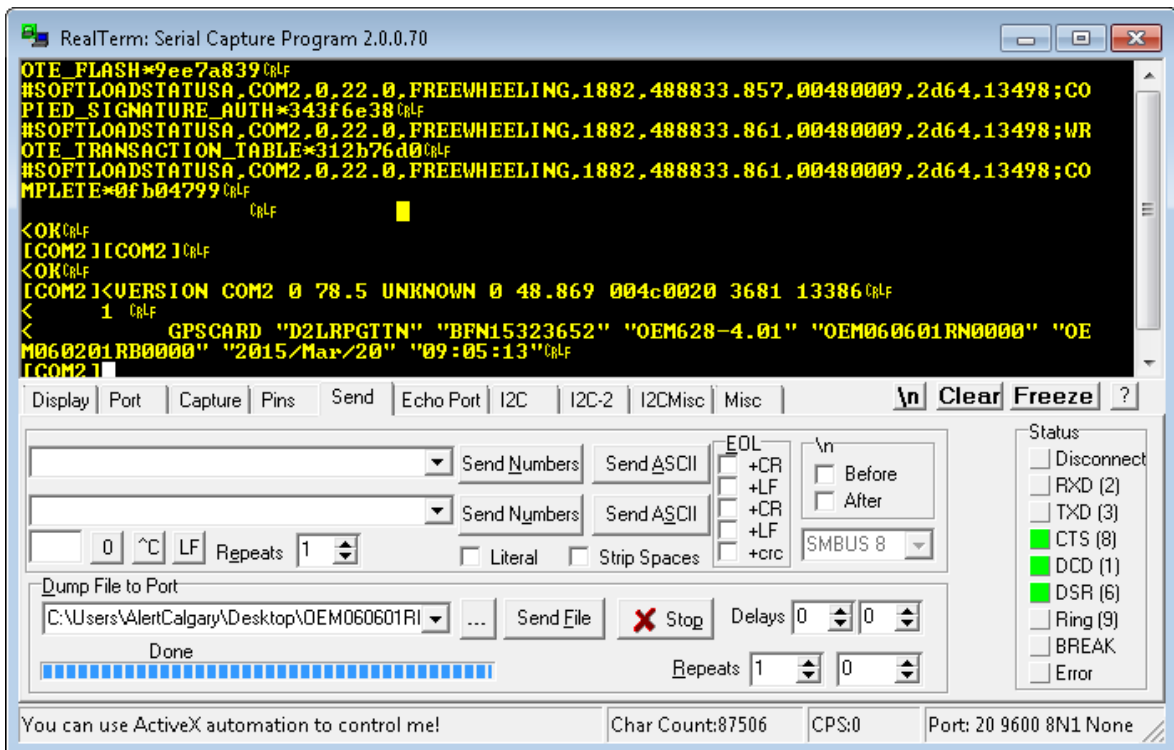

SoftLoad errors

It is possible for errors to occur during the SoftLoad update. All command responses should be checked to verify all issued commands were accepted. The SoftLoad status should also be monitored in the **SOFTLOADSTATUS** log. Any status enum value greater than the ERROR status indicates an error has occurred during the SoftLoad update. In the event of an error, the SoftLoad update should be restarted by issuing a **SOFTLOADRESET** command or normal operation can be restored by resetting the receiver.

In rare cases after a SoftLoad error, the boot code may not be able to determine which is the latest firmware to be executed. To protect against this, SoftLoad does not erase the previous valid firmware image from flash on the receiver. In such cases, the boot code will execute the old image and raise the "Safe Mode" error (see **RXSTATUS** log). If that error is detected, simply restart the SoftLoad process to reload the new firmware image and the error will be resolved.

11.6.3 Self-implement the SoftLoad process

This method is appropriate for users with deeply embedded systems and that want to customize the firmware updating process to their application. C++ source code is available to provide example code of processing S-Records and converting them to NovAtel format commands.

Contact Customer Support at novatel.com/support and ask about the srec2softload utility. The C++ source code can then be customized to your application.

SoftLoad commands and logs

Refer to the [OEM7 Commands and Logs Reference Manual](#) for detailed log and command information.

Command	Description
SOFTLOADRESET	Initiate a new SoftLoad process
SOFTLOADSREC	Send an S-Record to the receiver for the SoftLoad process
SOFTLOADDATA	Send firmware image data to the receiver for the SoftLoad process
SOFTLOADCOMMIT	Complete the SoftLoad process
SOFTLOADSETUP	Send configuration information to the receiver for the SoftLoad process. This command is not required when working with a *.shex file
SOFTLOADFILE	Load a firmware image that has been loaded onto the internal storage of the receiver.

Log	Description
SOFTLOADSTATUS	Provides status updates for the ongoing SoftLoad process

Each command and log can be used in abbreviated ASCII, ASCII or binary format, with the exception of SOFTLOADDATA, which should only be used in binary format.

File types

Firmware data is stored in *.shex files as ASCII data in the form of S-Records, based on the Motorola S-Record format. The *.shex file includes a digital signature for the firmware.

Working with S-Records

Each S-Record has a header indicating the type of information contained in the record.

Records beginning with S0, S5 and S7 contain metadata about the firmware image, such as version information and which card types are supported by the firmware image.

Example S0 Record

```
S0~V~OM7MR0400RN0000
```

Example S5 Records

```
S50000
S503D9FE25
S5033158D5A
```

Example S7 Records

```
S70000
S70500000000FA
```

Records beginning with S3 contain the actual firmware image data. Aside from the header, each pair of characters forms the ASCII representation of a binary byte. The format is as follows:

S3	LL	AAAAAAA	DDDDDDDD...DDDDDDDD	CC
		Check Sum		
		Little Endian Data. These bytes are copied into the "data" field of the SOFTLOADDATA command		
		4 - Byte Address. Set this as the value of "offset" in the SOFTLOADDATA command		
Length. This is the hexadecimal number of character pairs to follow in the record. This value minus 4 bytes for the address and 1 byte for the check sum is copied into the "data length" field of the SOFTLOADDATA command				
Header				

Sending firmware data

The **SOFTLOADSREC** and **SOFTLOADDATA** commands can be used to send firmware data from *.shex files to the receiver.

S0, S5 and S7 S-Records should be sent directly to the receiver using the **SOFTLOADSREC** command, by enclosing the S-Record in quotation marks and issuing the command to the receiver, as follows:

```
SOFTLOADSREC "<S-RECORD>"
```

S3 records can be sent individually to the receiver using the **SOFTLOADSREC** command. Alternatively, the data from an S3 record can be parsed and packaged together with data from other S3 records into a binary **SOFTLOADDATA** command. Packaging data parsed from multiple S3 records into a binary **SOFTLOADDATA** command can result in improved firmware update times as each S3 record contains only a small number of bytes of firmware data. A single **SOFTLOADDATA** command can package up to 4096 bytes of firmware data from multiple S3 records, whereas a single **SOFTLOADSREC** command contains a maximum of 28 bytes of firmware data from a single S3 record.

Multiple S3 records can be packaged into a single **SOFTLOADDATA** command as long as the data from one S3 record follows immediately after the previous record. That is, the address from the current S3 record must equal the address from the previous S3 record plus the data length of the previous S3 record. If the data is not consecutive then the **SOFTLOADDATA** command can be sent with the amount of data it has packaged up to that point. Subsequent data can be packaged in a new **SOFTLOADDATA** command. Within the **SOFTLOADDATA** command, the "offset" field remains the address of the first S3 record and the "data" and "data length" are updated to include the new data.

The *.shex file data may contain many gaps and jumps. For example, in many NovAtel *.shex files, data for address 0x000_00000 is stored near the very end of the file.

Example packaging multiple S3 Records in a SOFTLOADDATA command

Start a new **SOFTLOADDATA** command

```
S32100407AD48FCA63034B80F5CE0C36507DE3D8DCC0C6C0C00515D74BCACF2F2949E1
```

Address: 0x00407AD4 Num Data Bytes: 0x21 – 0x01 – 0x04 = 0x1C

```
S32100407AF04CCA4985F0F7B081E41D9B7D806C26989AE2D4E4CCBCB47C10FBFD3E43
```

Previous Address + Previous Num Bytes = 0x00407AD4 + 0x1C = 0x00407AF0

Address: 0x00407AF0 Num Data Bytes: 0x1C

Add data to existing **SOFTLOADDATA** command

```
S30D00407B0CDE0400A6374D5BFFC5
```

Previous Address + Previous Num Bytes = 0x00407AF0 + 0x1C = 0x00407B0C

Address: 0x00407B0C Num Data Bytes: 0x0D – 0x01 – 0x04 = 0x08

Add data to existing **SOFTLOADDATA** command

```
S3210000000007F0A7F1F4060000147B4000F49217813C7BB00014493F005C00000009
```

Previous Address + Previous Num Bytes = 0x00407B0C + 0x08 = 0x00407B14

Address: 0x00000000 Num Data Bytes: 0x1C

Requires new **SOFTLOADDATA** command because address does not match previous address + previous number of data bytes

Send existing **SOFTLOADDATA** command, and start a new **SOFTLOADDATA** command

```
S3210000001C80040000E001000030000000082B0100D8060000E4060000C806000063
```

Address: 0x0000001C Num Data Bytes: 0x1C

Previous Address + Previous Num Bytes = 0x00000000 + 0x1C = 0x0000001C

Add data to existing **SOFTLOADDATA** command

The **SOFTLOADDATA** command must be sent as a NovAtel binary format command.

SoftLoad update method

This section describes the sequence of commands that are issued to the receiver when updating using a *.shex file.



The response for each command must be processed before sending the next command so as to determine if the command was accepted or rejected, and to wait for the receiver to complete the operation. Responses to SoftLoad commands are guaranteed to be output from the receiver within a specific time, which varies by command. Refer to specific SoftLoad command for more information on responses and the timeout values for SoftLoad commands.

1. Open a connection to any port on the receiver (COM, USB or ICOM) with the input and output INTERFACEMODE set to NOVATEL.
2. Request the SOFTLOADSTATUS log using the following command:

```
LOG SOFTLOADSTATUSA ONCHANGED
```
3. Initialize SoftLoad with a **SOFTLOADRESET** command. This command stops all tracking on the receiver to ensure sufficient memory is available for the loading process. An RXSTATUSEVENTA log

reports a SoftLoad In Progress status.

4. Open the *.shex firmware file.
5. Read each line of the *.shex firmware file.
 - a. Send S0, S5 and S7 S-Records directly to the receiver using the **SOFTLOADSREC** command. The S-Record must be enclosed in quotation marks:
SOFTLOADSREC "<S-RECORD>"
Data within S0 records can also be sent to the receiver by converting them to **SOFTLOADSETUP** commands. Refer to the **SOFTLOADSETUP** command in the [OEM7 Commands and Logs Reference Manual](#) for details on how to convert from S0 S-Records to **SOFTLOADSETUP** commands.
 - b. S3 S-Records should be parsed and packaged into a **SOFTLOADDATA** command.
6. Send the **SOFTLOADCOMMIT** command after all data from the *.shex file has been transferred to the receiver. The SOFTLOADSTATUS log reports the status of the loading process. Wait for a SOFTLOADSTATUS log to indicate the status is COMPLETE. The COMPLETE status or an error is guaranteed to be output from the receiver within 300 seconds from the time the **SOFTLOADCOMMIT** command was received by the receiver.
7. Send the auth-code for the newly downloaded image using the **AUTH** command. This is only required if there is not already a signature auth-code on the receiver as signature auth-codes are maintained through a SoftLoad update. See *Authorization code* on page 153 for details on Auth-Codes.

```
AUTH ADD_DOWNLOAD <AUTH CODE>
```

8. Reset the receiver using any of the following methods:
 - Enter the **RESET** command
 - Enter the **FRESET** command
 - Power-cycle the receiver

Once the receiver resets, the new version of firmware is active.

The SoftLoad process can be safely cancelled at any time using the **SOFTLOADRESET** command or by otherwise resetting the receiver. Once the COMPLETE status is reported by SOFTLOADSTATUS, the new firmware image will be run after the receiver is reset.

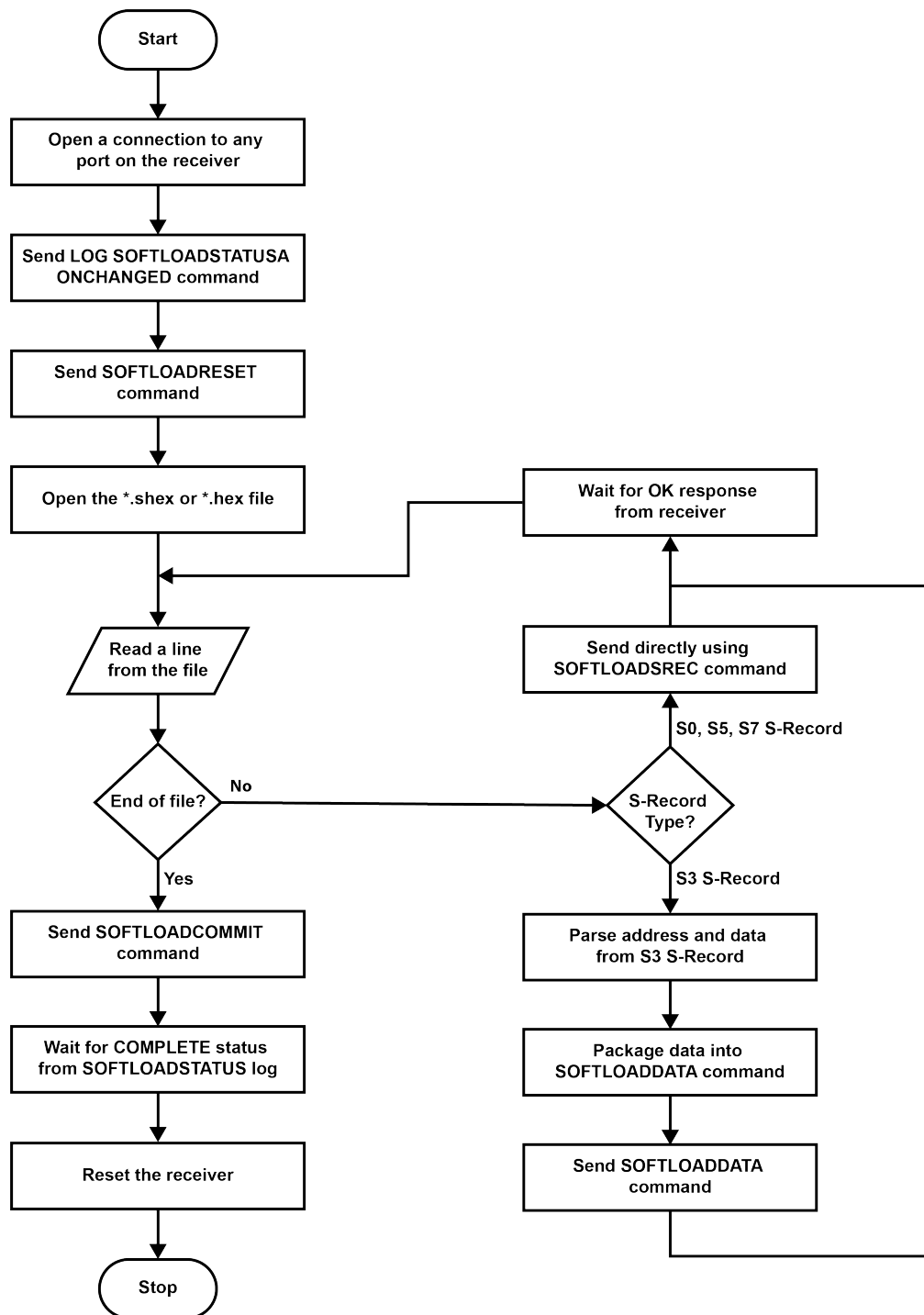

SoftLoad errors

It is possible for errors to occur during the SoftLoad update. All command responses should be checked to verify all issued commands were accepted. The SoftLoad status should also be monitored in the **SOFTLOADSTATUS** log. Any status enum value greater than the ERROR status indicates an error has occurred during the SoftLoad update. In the event of an error, the SoftLoad update should be restarted by issuing a **SOFTLOADRESET** command or normal operation can be restored by resetting the receiver.

In rare cases after a SoftLoad error, the boot code may not be able to determine which is the latest firmware to be executed. To protect against this, SoftLoad does not erase the previous valid firmware image from flash on the receiver. In such cases, the boot code will execute the old image and raise the "Safe Mode" error (see

RXSTATUS log). If that error is detected, simply restart the SoftLoad process to reload the new firmware image and the error will be resolved.

11.7 Update Manage Web

Manage Web is hosted on the OEM7 receiver. To update Manage Web, a new Manage Web software package is loaded onto the receiver.

11.7.1 Update Manage Web content using NovAtel Application Suite

To update Manage Web on the receiver:

1. Obtain the new Manage Web file.

The latest version of Manage Web content is available on the NovAtel website (novatel.com/support).



Copy the Manage Web file to the device's local drive before uploading.

2. Connect a computer to the receiver using a serial (COM) cable, USB cable or Ethernet connection.
3. Start NovAtel Application Suite on the computer.
4. Use NovAtel Application Suite to connect to the receiver.

For information about using NovAtel Application Suite, refer to docs.novatel.com/Tools.

5. On the *Status and Configuration* window, click the **Device** menu and select **Update**.

The *Update* window appears.

6. Click the **Browse** button.
7. Navigate to the directory that contains the new Manage Web file and select the file.
8. Click the **Open** button.

The Update window appears with the name of the selected file in the Select File field.

9. Click the **Apply** button.

After the new software is loaded, the receiver will restart.

11.7.2 Update Manage Web content using Manage Web

To update Manage Web on the receiver:

1. Obtain the new Manage Web file.

The latest version of Manage Web content is available on the NovAtel website (novatel.com/support).



Copy the Manage Web file to the device's local drive before uploading.

2. Connect the receiver to a computer using an Ethernet connection.
3. Open a web browser and enter **192.168.19.1** in the address (URL) bar of the browser.

If using an Ethernet connection, enter the IP address assigned to the receiver.

The Manage Web Home page appears.

4. Click the Menu icon and select **Update**.

5. Click the **Select File** button
6. Navigate to the folder in which the new Manage Web software to load is stored and select the software file.
7. Click the **Apply** button.

After the new software is loaded, the receiver will restart.

Chapter 12 Troubleshooting

There are simple ways to diagnose and resolve problems. In many cases, the issue can be resolved within a few minutes, avoiding the inconvenience and loss of productivity that results from having to return the receiver for repair. This section discusses troubleshooting issues and includes cross-references to other sections of the manual that may help resolve problems.

If unsure of the symptoms or if the symptoms do not match any of those listed, use the RXSTATUS log to check the receiver status and error words. See *Examining the RXSTATUS log* on the next page.

Try to resolve the problem using the troubleshooting guide in *Table 22: Troubleshooting based on symptoms* below, then try our Knowledge Base at novatel.com/support. If you are still not able to resolve the problem, see *Customer Support* on page 16 for troubleshooting logs and contact information.

Table 22: Troubleshooting based on symptoms

Symptom	Related section
The receiver is not properly powered	Check the power cable. Replace if faulty. See <i>Power supply requirements for the CPT7</i> on page 29
The receiver cannot establish communication	Check the serial cables and ports. Replace if faulty. See <i>CAN bus</i> on page 141. Refer also to the SERIALCONFIG command.
The receiver is not tracking satellites	Ensure that the antenna has an unobstructed view of the sky from horizon to horizon. Check the RXSTATUS error states. See <i>Examining the RXSTATUS log</i> on the next page. If the receiver is in error mode, it does not track. Use the Interference Toolkit to check if there is an interference signal present. See <i>Interference Toolkit</i> on page 70. Check the antenna cable. Replace if faulty. See <i>Selecting a GNSS antenna</i> on page 28 and <i>Choosing a coaxial cable</i> on page 29.
No data is being logged	Refer to <i>CAN bus</i> on page 141 and <i>Communications with the receiver</i> on page 44
Random data is being output by the receiver or binary data is streaming	Check the baud rate on the receiver and in the communication software. Refer to the SERIALCONFIG command and FRESET command. See also <i>CAN bus</i> on page 141.
A command is not accepted by the receiver	Check for correct spelling and command syntax. See <i>Communications with the receiver</i> on page 44 and refer to the FRESET command in the OEM7 Commands and Logs Reference Manual

Symptom	Related section
Differential mode is not working properly	See <i>Transmitting and receiving corrections</i> on page 49 and refer to the SERIALCONFIG command.
There appears to be a problem with the receiver's memory	Refer to the NVMRESTORE command.
An environmental or memory failure. The receiver temperature is out of acceptable range or the internal thermometer is not working	Move the receiver to within an acceptable temperature range. See: <ul style="list-style-type: none"> • <i>High temperature environments</i> on page 179 • <i>CPT7 electrical and environmental specifications</i> on page 195
Overload and overrun problems. Either the CPU or port buffers are overloaded	Reduce the amount of logging or increase the baud rate.
The receiver is indicating that an invalid authorization code has been used	Refer to the VERSION log or VALIDMODELS log and the MODEL command or AUTH command.
The receiver is being affected by jamming	Move the receiver away from any possible jamming sources
The receiver is being affected by interference	See <i>Interference Toolkit</i> on page 70. Move the GNSS antenna away from the source of the interference signal. If the interference mitigation feature is enabled on the receiver, configure a filter within the Interference Toolkit to filter out the interference signal.
The receiver's Automatic Gain Control (AGC) is not working properly	See the jamming symptom in this table

For information about the commands and logs in this section, refer to the [OEM7 Commands and Logs Reference Manual](#).

12.1 Examining the RXSTATUS log

The RXSTATUS log provides detailed status information about your receiver and can be used to diagnose problems. Refer to the **RXSTATUS** log for details on this log and on how to read the receiver error word and status word. *Table 23: Resolving a receiver error word* below, *Table 24: Resolving an error in the receiver status word* on the next page and *Table 25: Resolving an error in the AUX1 status word* on page 177 have actions to take when your receiver has an error flag in these words. If you are not able to resolve the condition, contact *Customer Support* on page 16.

Table 23: Resolving a receiver error word

Bit set	Action to resolve
0-2	Issue a FRESET command (for bit 1, reload new firmware).
4	Contact <i>Customer Support</i> on page 16.

Bit set	Action to resolve
5	Check the VERSION log. The VERSION log will indicate "Invalid auth-code". Upgrade the auth-code as described in <i>Applying a Software Model with an auth-code</i> on page 153.
6	Issue a FRESET command
7	See <i>Power supply requirements for the CPT7</i> on page 29
8	Reserved
9	<p>Check the temperature ranges in:</p> <ul style="list-style-type: none"> • <i>CPT7 electrical and environmental specifications</i> on page 195 <div style="border: 1px solid #ccc; padding: 10px; margin-top: 10px;">  The operating temperatures are ambient air temperatures. The temperature sensors on the receiver PCB will reflect higher operating temperatures (refer to the HWMONITOR log). The PCB temperature sensors will trigger a receiver warning and receiver error at 100°C and 110°C respectively. The warning and error conditions are captured using the RXSTATUS log. </div>
10	Possible hardware or environmental condition. If you cannot resolve the problem, contact <i>Customer Support</i> on page 16.
11	<p>Possible hardware or environmental condition. If you cannot resolve the problem, contact <i>Customer Support</i> on page 16.</p> <p>Also, check the Auxiliary 2 Status word to determine which PLL is in error.</p>
12-14	Reserved
15	Issue a FRESET command and power cycle the unit. If the bit is still present, contact <i>Customer Support</i> on page 16.
16	Monitor CPU idle time. Reduce number of logs or the rate of data logging.
17	Ensure that the Version log is consistent with the hardware.
18-19	Reserved
20	SoftLoad is in progress. See <i>Updating using SoftLoad commands</i> on page 160.
21	You may be exceeding the receiver's velocity limit. If so, reduce velocity. This error can only be cleared by resetting the receiver.
22	Reload firmware using NovAtel Application Suite or the SoftLoad commands.
23-30	Reserved
31	Possible hardware failure. Contact <i>Customer Support</i> on page 16.

Table 24: Resolving an error in the receiver status word

Bit set	Action to resolve
0	Check the Error Word in the RXSTATUS log. See also <i>Table 23: Resolving a receiver error word</i> on the previous page

Bit set	Action to resolve
1	Check the temperature ranges in <ul style="list-style-type: none"> • <i>CPT7 electrical and environmental specifications</i> on page 195
2	See <i>Power supply requirements for the CPT7</i> on page 29
3	See <i>Selecting a GNSS antenna</i> on page 28, <i>Choosing a coaxial cable</i> on page 29, <i>Antenna LNA power</i> on page 33
4	
5	
6	
7	Check the CPU idle time. Check for unnecessary logging. Check for simultaneous use of functionality.
8	See <i>Table 9: Serial ports supported</i> on page 46 Also, check the Auxiliary 2 Status word to determine which COM port has overrun its buffer.
9-11	Reserved
15	Check the Auxiliary 1 status word to determine which RF channels are jammed.
16-17	Reserved
18	When the receiver has tracked GNSS satellites long enough for a valid almanac to be received, this bit will be set to 0.
19	None. This bit only indicates if the receiver has calculated a position.
20	None. This bit is a status bit indicating if the receiver's position has been manually fixed and does not represent a problem. Refer also to the FIX command.
21	None. This bit indicates if clock steering has been manually disabled. Refer also to the FRESET command.
22	None. This bit only indicates if the clock model is valid. Refer also to the FRESET command.
23	None. This bit indicates if the phase-lock-loop is locked when using an external oscillator. Refer also to the FRESET command.
24	Check the CPU idle time. Check for unnecessary logging. Check for simultaneous use of functionality.
25-26	None. These bits identify the receiver family. For OEM7 receivers, bit 25 is set to 1 and bit 26 is set to zero.
27	Interference Toolkit HDR mode status. When this bit is set to 1, Interference Toolkit HDR mode is enabled.
28	Digital filter status. When this bit is set to 1, an Interference Toolkit digital filter is enabled.
29	None. This bit indicates if any bits in the auxiliary 3 status word are set. The auxiliary 3 word provides status information and does not contain any new information on problems. Refer also to the FRESET command.

Bit set	Action to resolve
30	None. This bit indicates if any bits in the auxiliary 2 status word are set. The auxiliary 2 word provides status information and does not contain any new information on problems. Refer also to the FRESET command.
31	None. This bit indicates if any bits in the auxiliary 1 status word are set. The auxiliary 1 word provides status information and does not contain any new information on problems. Refer also to the FRESET command.

For information about the commands and logs in this section, refer to the [OEM7 Commands and Logs Reference Manual](#).

12.2 Examining the AUX1 status word

Table 25: Resolving an error in the AUX1 status word below provides actions to take when your receiver has an error flag in the AUX1 status word.

Table 25: Resolving an error in the AUX1 status word

Bit set	Action to resolve
0-2	Jammer detected
3	None. This bit indicates that Position Averaging is ON
4-6	Jammer detected
7	Connect the receiver via USB
8-10	Reduce the amount of logging on the USB ports
11	(Reserved bit)
12	None. This bit indicates a Profile set using the PROFILE command is activated.
13	Throttled Ethernet Reception Check for unusually high Ethernet traffic being directed to the Receiver. This does not represent an error condition on the receiver, but suggests there may be an issue in the network environment on the receiver.
14-17	AGC error on RF1 through RF4 respectively. To resolve, ensure the antenna cable is connected and signal input level is within specification. Contact NovAtel <i>Customer Support</i> on page 16 for additional information.
18	Connect the receiver via Ethernet. See <i>Ethernet port</i> on page 39
19-21	Reduce the amount of logging on the Ethernet ports
22-24	Reduce the amount of logging on the NTRIP ports
25-27	Reduce the amount of logging on the Virtual COM ports

Bit set	Action to resolve
28-29	AGC error on RF5 (bit 28) or RF6 (bit 29). To resolve, ensure the antenna cable is connected and signal input level is within specification. Contact NovAtel <i>Customer Support</i> on page 16 for additional information.
30-31	(Reserved bits)

Table 26: RF paths for OEM7 receivers

RF path	OEM719, OEM729, OEM7700, PwrPak7, CPT7700, SMART7	OEM7720, PwrPak7D, CPT7	OEM7500, OEM7600, SMART2
RF1	GPS L1 GLONASS L1 Galileo E1 BDS B1 QZSS L1 SBAS L1	1st antenna GPS L1 GLONASS L1 Galileo E1 BDS B1 QZSS L1 SBAS L1	GPS L1 GLONASS L1 Galileo E1 BDS B1 QZSS L1 SBAS L1
RF2	Reserved	Reserved	GPS L2/L5 GLONASS L2/L3 Galileo E5 BDS B2 QZSS L2/L5 NavIC L5 SBAS L5
RF3	GPS L2 GLONASS L2 Galileo E6 BDS B3 QZSS L2/L6	1st antenna GPS L2/L5 GLONASS L2/L3 Galileo E5 BDS B2 QZSS L2/L5 NavIC L5 SBAS L5	Reserved
RF4	GPS L5 GLONASS L3 Galileo E5 BDS B2 QZSS L5 NavIC L5 SBAS L5	2nd antenna GPS L1 GLONASS L1 Galileo E1 BDS B1 QZSS L1	Reserved

RF path	OEM719, OEM729, OEM7700, PwrPak7, CPT7700, SMART7	OEM7720, PwrPak7D, CPT7	OEM7500, OEM7600, SMART2
RF5	Reserved	2nd antenna GPS L2/L5 GLONASS L2/L3 Galileo E5 BDS B2 QZSS L2/L5 NavIC L5	Reserved
RF6	Reserved	Reserved	Reserved

12.3 High temperature environments

The operating temperature of OEM7 receivers increases as more features (channels used, HDR mode, etc.) are enabled.

When the receiver is operating in an environment that is near its maximum ambient temperature, an increase in the ambient air temperature or enabling additional features may cause the receiver to exceed its maximum operating temperature and generate a Temperature Status error. When a Temperature Status error occurs, the receiver idles all channels, turns off the antenna and disables the RF hardware. The communication interfaces continue to function so commands can be sent and logs received.

12.3.1 Indicators of an error state

The indications that the receiver is in an error state, such as a Temperature Status error, are:

- Logs that have a solution status will show `INSUFFICIENT_OBS` as the Solution Status.
- The **RXSTATUSEVENT** log is output on all communication ports. This log will indicate an error condition in the Receiver Error word of the log.
- All logs output have Bit 0 set in the Receiver Status word of the log header.

To determine the cause of the error, log the **RXSTATUS** log and check the Receiver Error word. If Bit 9 is set, it is a Temperature Status error. For information about reading the Error Word, refer to *Error word* on page 149.

12.3.2 Recovering from a temperature status error

The receiver must be reset or power cycled to recover from a receiver error such as a Temperature Status error.

Log information is lost when the receiver is reset. Therefore, any logs required to identify and troubleshoot the error, such as the **RXSTATUS** log, should be collected before resetting the receiver.

Also, steps should be taken to reduce the cause of the receiver temperature error to prevent the error from occurring again. See *Mitigating high receiver temperature* below.

12.3.3 Mitigating high receiver temperature

If the receiver has a high temperature warning or error, use one or more of the following suggestions to reduce the receiver temperature.

- If possible, reduce the ambient temperature around the receiver or move the receiver to an area with a lower ambient temperature.

- Disable the receiver features that are not required for the current operation of the receiver.
- Mount the CPT7 on a metal surface such as the NovAtel mount adapter or the metal vehicle chassis. This will allow heat to leave the CPT7 through contact with the metal surface and allow more optimized performance

12.3.4 Monitoring the receiver temperature

If the receiver is operating in a high ambient temperature environment, you can monitor the receiver temperature using the RXSTATUS and HWMONITOR logs.

1. Log the **RXSTATUS** log and check Bit 1 of the Receiver Status word.

```
LOG RXSTATUS onchanged
<RXSTATUS USB1 0 81.5 FINESTEERING 1990 326146.020 0a104020 2ae1 14434
< 00000000 5
< 0a104020 00000000 00030000 00030000 (Receiver Status)
< 00062000 00001008 00000000 00000000
< 00000000 00000000 80000000 00000000
< 80000000 00000000 00000000 00000000
< 00000000 00000000 00000000 00000000
```

For information about reading the Receiver Status word, refer to *Status word* on page 149.

2. If Bit 1 is 0, the temperature is okay. Continue monitoring, but no action is required.
If Bit 1 is 1, the receiver temperature has exceeded the warning limit.
3. Log the **HWMONITOR** log and check the two temperature status fields (0x01 and 0x16).

```
LOG HWMONITOR ontime 30
<HWMONITOR USB1 0 77.5 FINESTEERING 1990 326851.000 0a104020 52db
14434
< 10
< 58.424915314 100 (Temperature 0x01)
< 0.000122100 200
< 3.296703339 600
< 5.169230938 700
< 1.192307711 800
< 3.300366402 f00
< 1.833943844 1100
< 5.159462929 1500
< 1.555555582 1700
< 58.485961914 1600 (Temperature 0x16)
```

Pay attention to the reading and the boundary limit status.

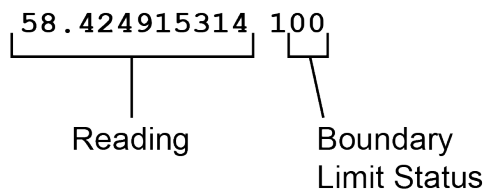

Refer to Table: HWMONITOR Status Table in the **HWMONITOR** log section for a description of the Boundary Limit Status.

4. Use the suggestions in *Mitigating high receiver temperature* on the previous page to reduce the receiver temperature.
5. Continue monitoring the **HWMONITOR** log to see if receiver temperature is dropping.

6. Check the **RXSTATUS** log to see if the temperature status changes to Okay (Bit 1 in the Receiver Status word changes to 0).

12.4 Safe Mode

Safe Mode is an error condition triggered on the OEM7 receiver if it encounters certain critical problems during start-up. The receiver does not track GNSS satellites in this state, but the user interface is still available to allow for diagnosis of the problem.

The receiver will enter Safe Mode under certain rare cases including the following:

- Corrupted or bad data within the receiver Non-Volatile Memory (NVM).
- An unsupported Auth-Code.
- The expected main firmware image could not be found by the boot code. This is possibly due to an error during the main firmware loading process (i.e. NovAtel Application Suite, SoftLoad, etc.).

Safe Mode exists to allow users to take steps to recover the receiver after such an error occurs. Potential recovery steps are described in *Recovery steps* below.

Safe Mode is indicated by an error bit in the **RXSTATUS** log.

12.4.1 Reset loop detection

In order to determine when the Safe Mode error should be triggered, OEM7 receivers have the ability to detect when an unexpected reset has occurred during the boot process. If a Reset Loop is detected, the **Reset Loop Detected** bit is set in the **RXSTATUS** log.

This bit is only a warning and the receiver may still be able to operate correctly. The receiver will allow several unexpected resets to occur before triggering the Safe Mode Error, at which point the receiver will not track GNSS satellites.

12.4.2 Recovery steps

If the **Safe Mode** error bit or the **Reset Loop Detected** warning bit are set in the **RXSTATUS** log, take the following steps to diagnose and recover the system:

1. Request the **SAFEMODESTATUS** log and determine the current *Safe Mode State* of the system.
2. Reference Table: Safe Mode States in the [OEM7 Commands and Logs Reference Manual](#) and find the suggested actions for the current Safe Mode State.
3. If the suggested actions do not resolve the issue, contact NovAtel Customer Support.

Appendix A CPT7 technical specifications

Table 27: CPT7 physical description

Physical	
Size	90 mm x 76 mm x 60 mm
Weight	500 grams

See the following sections for more information about the CPT7:

- *CPT7 performance specifications* on the next page
- *CPT7700 performance specifications* on page 186
- *CPT7 IMU performance specifications* on page 189
- *CPT7 mechanical specifications* on page 190
- *CPT7 electrical and environmental specifications* on page 195
- *CPT7 data communication specifications* on page 198
- *CPT7 strobe specifications* on page 199
- *CPT7 connectors* on page 200
- *CPT7 I/O1 cable* on page 202
- *CPT7 I/O2 cable* on page 204

A.1 CPT7 performance specifications

All specifications subject to GNSS system characteristics.

Table 28: CPT7 receiver performance

Accuracy		
Position accuracy ¹	Single point L1	1.5 m RMS
	Single point L1/L2	1.2 m RMS
	SBAS ²	60 cm RMS
	DGPS	40 cm RMS
	TerraStar-L ³	40 cm RMS
	TerraStar-C PRO ³	2.0 cm RMS
	TerraStar-X ³	2.0 cm RMS
	RTK	1 cm + 1 ppm RMS
Time accuracy ⁴	<5 ns RMS	
Velocity accuracy	<0.03 m/s RMS	

1. Typical values under ideal, open sky conditions.

2. GPS-only.

3. Requires a TerraStar subscription which is available direct from NovAtel novatel.com/products/gps-gnss-correction-services/terrestar-correction-services.

4. Time accuracy does not include biases due to RF or antenna delay.

		Code	Carrier	
Measurement precision ¹	GPS	L1 C/A	4 cm	0.5 mm
		L2 P(Y)	8 cm	1.0 mm
		L2 C	8 cm	0.5 mm
		L5	3 cm	0.5 mm
	GLONASS	L1 C/A	8 cm	1.0 mm
		L2 P	8 cm	1.0 mm
		L2 C/A	8 cm	1.0 mm
	Galileo	E1	3 cm	0.5 mm
		E5a	3 cm	0.75 mm
		E5b	3 cm	0.75 mm
		E5 AltBOC	3 cm	0.75 mm
	BeiDou	B1I	4 cm	0.5 mm
		B1C	3 cm	0.5 mm
		B2I	4 cm	0.5 mm
		B2a	3 cm	0.5 mm
B2b ²		3 cm	0.5 mm	
ALIGN heading accuracy	Baseline = 2 m	0.08 degrees		
	Baseline = 4 m	0.05 degrees		
Velocity limit ³	600 m/s			

1. Measurement precision should be compared with measurements using the same correlator spacing.

2. Under good CN0 conditions, e.g. 44 dBHz.

3. Export licensing restricts operation to a maximum of 600 m/s, message output impacted above 585 m/s.

Signals		
Signals tracked ¹ primary antenna	GPS	L1 C/A, L1C, L2C, L2P, L5
	GLONASS	L1 C/A, L2 C/A, L2P, L3
	BeiDou	B1I, B1C, B2I, B2a, B2b
	Galileo ²	E1, E5 AltBOC, E5a, E5b
	NavIC (IRNSS)	L5
	QZSS	L1 C/A, L1C, L1S, L2C, L5
	SBAS	L1, L5
	L-band ³	Up to 5 channels
Signals tracked ⁴ secondary antenna	GPS	L1 C/A, L1C, L2C, L2P, L5
	GLONASS	L1 C/A, L2 C/A, L2P, L3
	BeiDou	B1I, B1C, B2I, B2a, B2b
	Galileo ⁵	E1, E5 AltBOC, E5a, E5b
	NavIC (IRNSS)	L5
	QZSS	L1 C/A, L1C, L1S, L2C, L5
Signal reacquisition	L1	<0.5 s (typical)
	L2 and L5	<1.0 s (typical)
Time to First Fix	Hot: <20 s (Almanac and recent ephemeris saved and approximate position and time entered) Cold: <34 s (No almanac or ephemeris and no approximate position or time)	
Data		
Data rates	GNSS measurements	up to 20 Hz
	GNSS position	up to 20 Hz
	INS solution	up to 200 Hz
	IMU raw data rate	100 Hz or 400 Hz

1. Signal availability based on model configuration.
2. E1bc support only.
3. Currently the receiver can track up to 3 L-band channels.
4. My new footnote
5. E1bc support only.

A.2 CPT7700 performance specifications

All specifications subject to GNSS system characteristics.

Table 29: CPT7700 receiver performance

Accuracy		
Position accuracy ¹	Single point L1	1.5 m RMS
	Single point L1/L2	1.2 m RMS
	SBAS ²	60 cm RMS
	DGPS	40 cm RMS
	TerraStar-L ³	40 cm RMS
	TerraStar-C PRO ³	2.0 cm RMS
	TerraStar-X ³	2.0 cm RMS
	RTK	1 cm + 1 ppm RMS
Time accuracy ⁴	<5 ns RMS	
Velocity accuracy	<0.03 m/s RMS	

1. Typical values under ideal, open sky conditions.

2. GPS-only.

3. Requires a TerraStar subscription which is available direct from NovAtel.

4. Time accuracy does not include biases due to RF or antenna delay.

		Code	Carrier	
Measurement precision ¹	GPS	L1 C/A	4 cm	0.5 mm
		L2 P(Y)	8 cm	1.0 mm
		L2C	8 cm	0.5 mm
		L5	3 cm	0.5 mm
	GLONASS	L1 C/A	8 cm	1.0 mm
		L2 P	8 cm	1.0 mm
		L2 C/A	8 cm	1.0 mm
	Galileo	E1	3 cm	0.5 mm
		E5a	3 cm	0.75 mm
		E5b	3 cm	0.75 mm
		E5 AltBoc	3 cm	0.75 mm
		E6	3 cm	0.75 mm
	BeiDou	B1I	4 cm	0.5 mm
		B1C	3 cm	0.5 mm
		B2I	4 cm	0.5 mm
		B2a	3 cm	0.5 mm
		B2b ²	3 cm	0.5 mm
		B3I	4 cm	0.5 mm
Velocity limit ³	600 m/s			

1. Measurement precision should be compared with measurements using the same correlator spacing.

2. Under good CN0 conditions, e.g. 44 dBHz.

3. Export licensing restricts operation to a maximum of 600 m/s, message output impacted above 585 m/s.

Signals		
Signals tracked	GPS	L1 C/A, L1C, L2C, L2P, L5
	GLONASS	L1 C/A, L2 C/A, L2P, L3
	BeiDou	B1I, B1C, B2I, B2a, B2b, B3I
	Galileo ¹	E1, E5 AltBOC, E5a, E5b, E6
	NavIC (IRNSS)	L5
	SBAS	L1, L5
	QZSS	L1 C/A, L1C, L1S, L2C, L5, L6
	L-band ²	Up to 5 channels
Signal reacquisition	L1	<0.5 s (typical)
	L2 and L5	<1.0 s (typical)
Time to First Fix	Hot: <20 s (Almanac and recent ephemeris saved and approximate position and time entered) Cold: <34 s (No almanac or ephemeris and no approximate position or time)	
Data		
Data rates	GNSS Measurements	up to 20 Hz
	GNSS Position	up to 20 Hz
	INS Position/Attitude	up to 200 Hz
	IMU Raw Data Rate	100 Hz / 400 Hz

1. E1bc and E6bc support only.

2. Currently the receiver can track up to 3 L-band channels.

A.3 CPT7 IMU performance specifications

Table 30: CPT7 IMU performance

Gyroscope performance	
Technology	MEMS
Dynamic range ¹	400 °/s
Bias instability	0.45 °/hr
Angular random walk	0.06 °/√hr
Accelerometer performance	
Technology	MEMS
Dynamic range	20 g
Bias Instability	0.075 mg
Velocity random walk	0.06 m/s/√hr

1. Performance specifications qualified to 325 °/s.

A.4 CPT7 mechanical specifications

- *Figure 50: CPT7 dimensions on the next page*
- *Figure 51: CPT7700 dimensions on page 192*
- *Figure 52: CPT7/CPT7700 alignment holes on page 193*
- *Figure 53: CPT7/CPT7700 centre of navigation on page 194*



In the following diagrams, the dimensions are in millimetres.

Figure 50: CPT7 dimensions

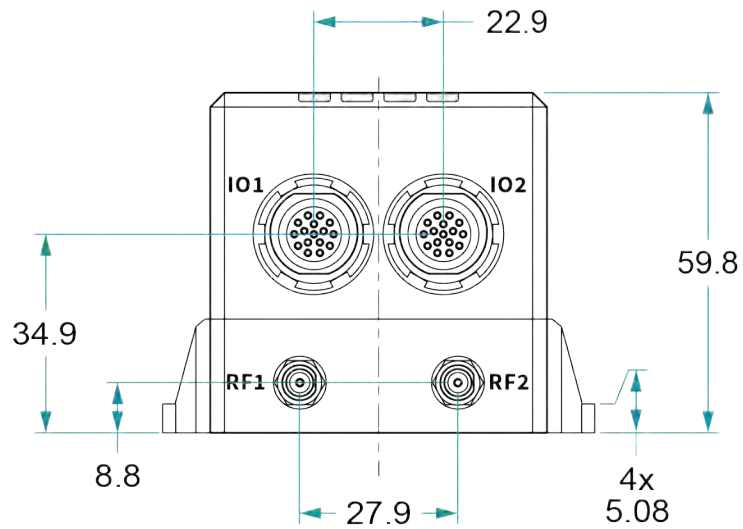
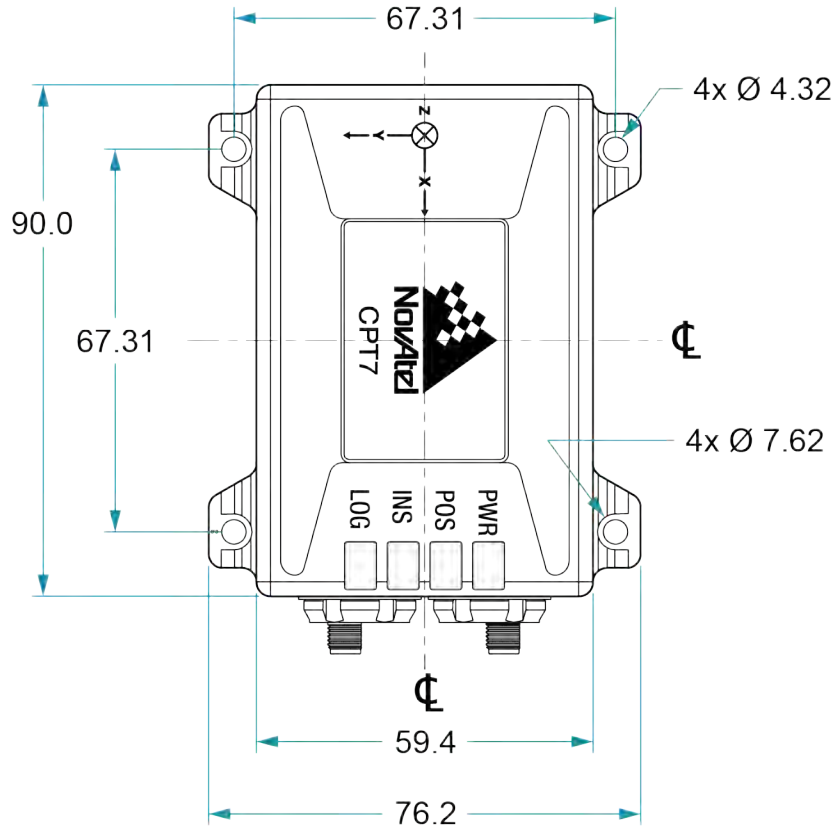

Figure 51: CPT7700 dimensions

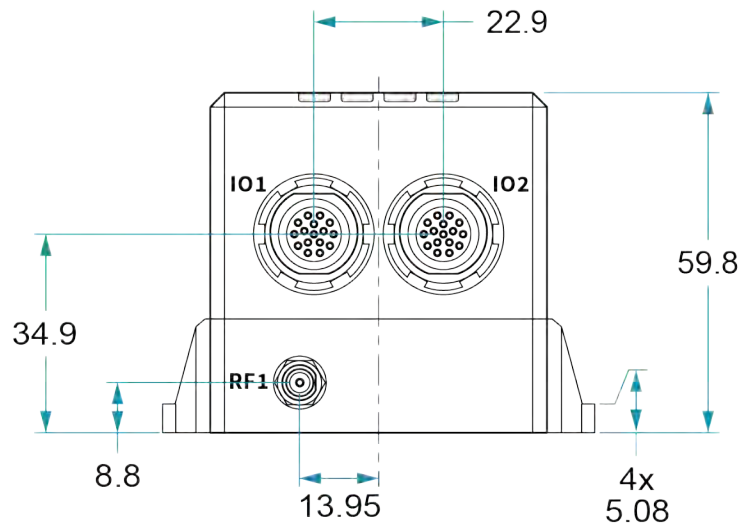
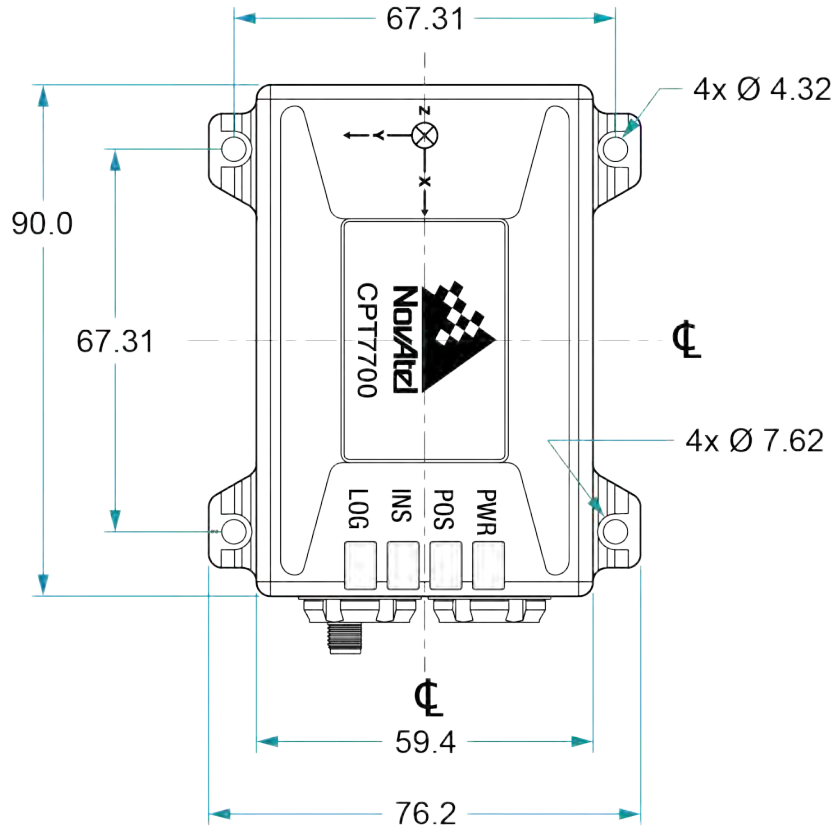

Figure 52: CPT7/CPT7700 alignment holes

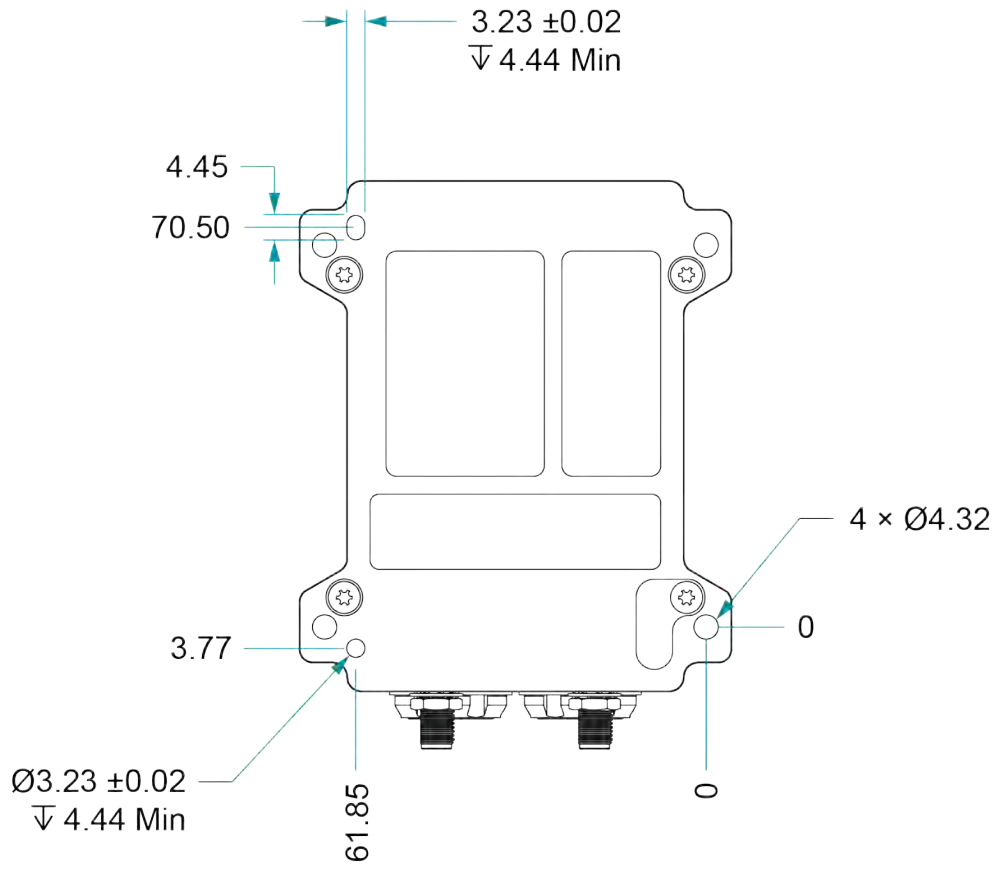
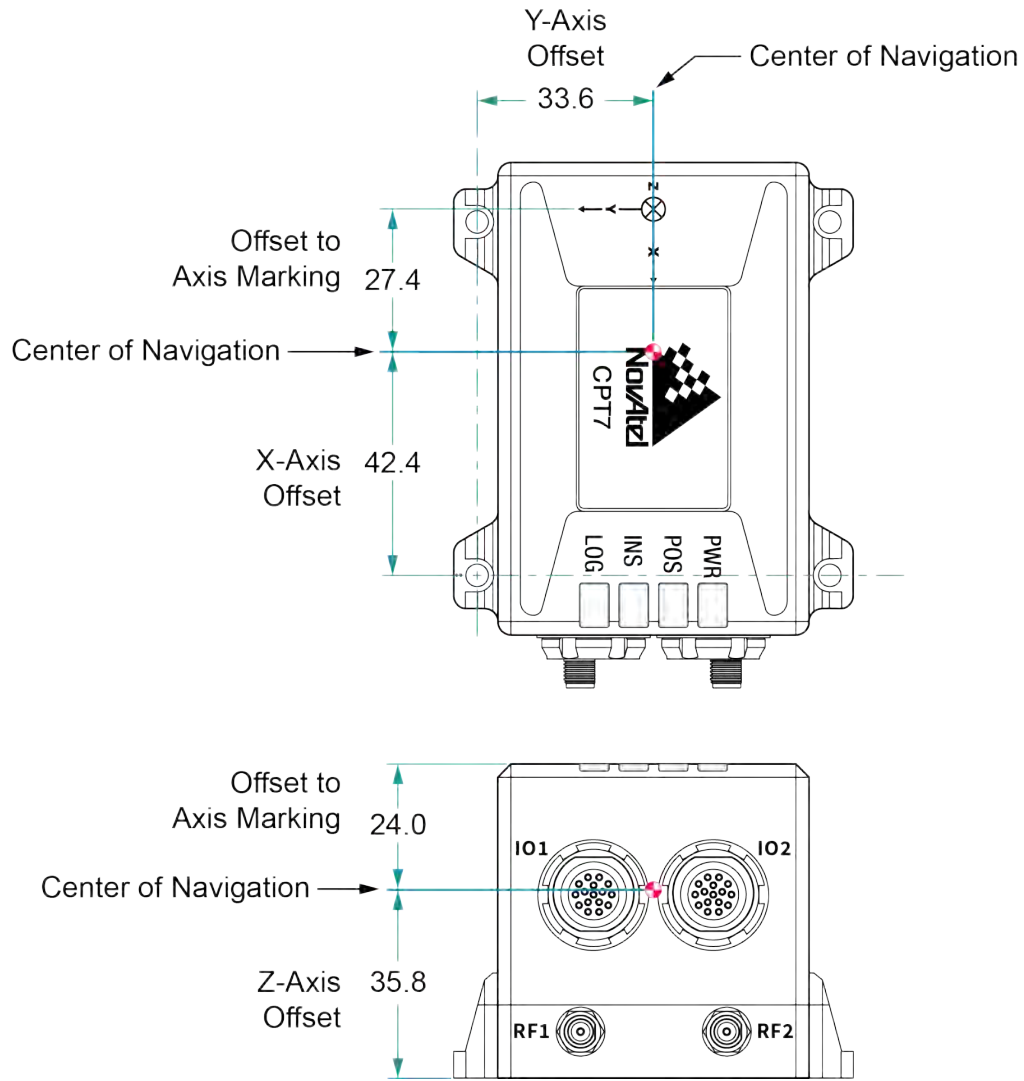

Figure 53: CPT7/CPT7700 centre of navigation



The axis marking on the CPT7 indicates the orientation of the X, Y and Z axis only. It does not indicate the centre of navigation. For the location of the centre of navigation, refer to *Figure 53: CPT7/CPT7700 centre of navigation* above.

A.5 CPT7 electrical and environmental specifications

Table 31: CPT7 environmental specifications

Environmental	
Operating temperature	-40°C to +71°C
Storage temperature	-40°C to +85°C
Humidity	95% non-condensing
Submersion	2 m for 12 hours (IEC 60529 IPX8)
Water resistance	MIL-STD-810H, Method 512.6
Dust resistance	MIL-STD-810H, Method 510.7 IEC 60529 IP6X
Random vibration	MIL-STD-810H, Method 514.8, Category 24, 7.7 g RMS
Sinusoidal vibration	IEC 60068-2-6
Bump	IEC 60068-2-27 Ea (25 g)
Shock – operating	MIL-STD-810H, Method 516.8, Procedure 1, 40 g, 11 ms terminal sawtooth
Acceleration	MIL-STD-810H, Method 513.8, Procedure II (G Loading - 15 g)

Table 32: CPT7 power requirements

Power	
Voltage	+9 to +36 VDC
Power consumption	<p>9 W typical, all constellations, all frequencies, plus L-band</p> <div style="border: 1px solid #ccc; padding: 10px; background-color: #e6f2ff;"> <p> These are typical values using serial ports without interference mitigation. These values can change with the number of satellites in view, firmware version, data logging rates and features in use. Use them as a guide for what you might expect but not as absolute values</p> </div>
Inrush current	5 A for less than 1.3 ms (@ 12 V; typical)

Table 33: CPT7 RF input/LNA power output

Radio frequency	
Antenna connectors	SMA female, 50 Ω nominal impedance

Radio frequency			
Cascaded antenna LNA gain (before receiver)	Firmware 7.04 or later	HDR disabled	+15 dB to +55 dB, 26 dB typical
		HDR enabled	+20 dB to +55 dB, 30 dB typical
	Firmware before 7.04	HDR disabled	+15 dB to +40 dB, 26 dB typical
		HDR enabled	+20 dB to +40 dB, 30 dB typical
RF input frequencies	GPS L1:	1575.42 MHz	
	GPS L2:	1227.60 MHz	
	GPS L5:	1176.45 MHz	
	GLONASS L1:	1593-1610 MHz	
	GLONASS L2:	1237-1254 MHz	
	GLONASS L3:	1202.025 MHz	
	Galileo E1:	1575.42 MHz	
Galileo E5a:	1176.45 MHz		
Galileo E5b:	1207.14 MHz		
Galileo E5:	1191.795 MHz		
BeiDou B1I:	1561.098 MHz		
BeiDou B1C:	1575.42 MHz		
BeiDou B2I:	1207.14 MHz		
BeiDou B2a:	1176.45 MHz		
BeiDou B2b:	1207.14 MHz		
L-band:	1545 to 1560 MHz (CPT7) ¹		
		1525 to 1560 MHz (CPT7700)	
LNA power	+5.0 VDC \pm 5%, 0 mA to 200 mA (supplied by receiver through centre conductor of RF connector).		

Table 34: CPT7 wheel sensor input signal levels

Parameter	Symbol		Conditions	Minimum	Typical	Maximum
Input current	I_{IN}	$V_{CC} = 0\text{ V}, 3.6\text{ V}, 5.5\text{ V}$	$V_{IN} = +12\text{ V}$		80 μA	125 μA
			$V_{IN} = -7\text{ V}$	-100 μA	-50 μA	

1. For hardware releases 1.10 and later. For earlier hardware versions, the L-band RF Input Frequency is 1525 to 1560 MHz.

Parameter	Symbol	Conditions	Minimum	Typical	Maximum
Receiver differential threshold voltage	V_{TH}	$-7\text{ V} \leq V_{CM} \leq +12\text{ V}^1$	-200 mV	-125 mV	-50 mV
Receiver input hysteresis	ΔV_{TH}	$V_A + V_B = 0\text{ V}$		15 mV	



There is a 100Ω termination resistor across the DMI_A+ and DMI_A- inputs.

1. V_{CM} is the common-mode input voltage.

A.6 CPT7 data communication specifications

Table 35: Data communications interfaces

COM1	
Electrical format	RS-232
Data rates	2400, 4800, 9600 (default), 19200, 38400, 57600, 115200 , 230400 or 460800 bit/s. ¹
Signals supported	COM1_Tx, COM1_Rx
CPT7 port	IO2
Connector on cable	DB9 female (on the CPT7 I/O2 Cable)
COM2	
Electrical format	RS-422
Data rates	2400, 4800, 9600 (default), 19200, 38400, 57600, 115200, 230400 or 460800 bit/s.
Signals supported	COM2_Tx+, COM2_Tx-, COM2_Rx+, COM2_Rx-
CPT7 port	IO1
Connector on cable	DB9 female (on CPT7 I/O1 Cable)
CAN bus	
Electrical format	ISO 11898-2
Data rates	1 Mbps maximum. CAN bus throughput is determined by slowest device on the bus
CPT7 port	IO2
USB	
Electrical format	Conforms to USB 2.0
Data rates	Hi-speed (480 Mb/s)
CPT7 port	IO2
ETHERNET	
Physical layer	10BASE-T/100BASE-TX
CPT7 port	IO2

1. The Legacy CPT7 receivers (PN 80023560) do not support 460800 bits/s.

A.7 CPT7 strobe specifications

Table 36: CPT7 strobes description



Strobes	CPT7 port	Input/Output	Factory default	Comment
EVENT_IN1	IO1	Input Leading edge triggered	Active low	Input marks for which a pulse greater than 150 ns triggers certain logs to be generated. (Refer to the MARKPOS, MARK2POS, MARK3POS, MARK1TIME, MARK2TIME and MARK3TIME logs and ONMARK trigger.) Polarity is configurable using the EVENTINCONTROL command.
EVENT_IN2	IO2			
EVENT_IN3	IO1			
EVENT_OUT1	IO1	Output	Active low	Programmable variable frequency outputs ranging from 0 Hz to 10 MHz (refer to the EVENTOUTCONTROL command). <div style="background-color: #fff9c4; padding: 5px; border: 1px solid #ccc;">  Minimum pulse period for the CPT7 EVENT_OUT lines is 50 ns. </div> <div style="background-color: #e1f5fe; padding: 5px; border: 1px solid #ccc; margin-top: 10px;">  If your application requires a higher frequency defined pulse (i.e. always 20 MHz at 50% duty cycle), the waveform can be regenerated external to the CPT7 by using a Schmitt trigger or buffer with appropriate limits set on the output line. </div>
EVENT_OUT2	IO2			
EVENT_OUT3	IO1			

Table 37: CPT7 strobe electrical specifications

Strobe	Symbol	Min (V)	Max (V)	Current (mA)
EVENT_IN1	V_{IL}	-	0.8	<±1 mA
EVENT_IN2	V_{IH}	2.0	3.3	
EVENT_IN3				
EVENT_OUT1	V_{OL}	-	0.4	±6 mA
EVENT_OUT2	V_{OH}	2.0	5.0	
EVENT_OUT3				

A.8 CPT7 connectors

The CPT7 has 2 Fischer Core 16 pin, circular connectors that provide access to the power and communication signals.

Figure 54: Fischer Core 16 pin connector

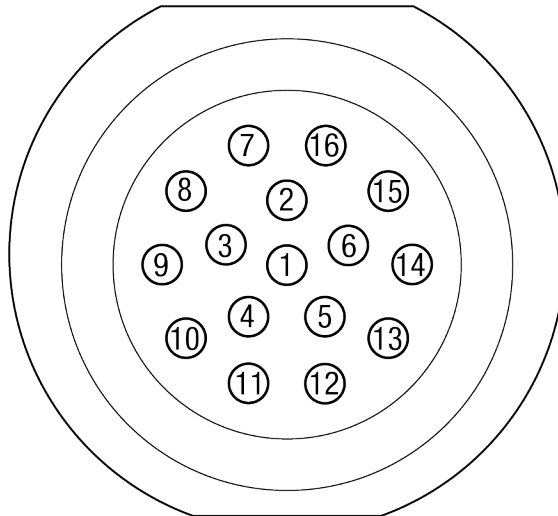

Table 38: IO1 pinout

Pin	Signal name	Description
1	EVENT_IN3	EVENT3 (Mark3) input
2	COM2_RX-	COM2 receive data negative. One half of the RS-422 receive differential pair.
3	Reserved	Reserved
4	Reserved	Reserved
5	EVENT_OUT3	EVENT3 (Mark3) output
6	COM2_TX-	COM2 transmit data negative. One half of the RS-422 transmit differential pair.
7	COM2_TX+	COM2 transmit data positive One half of the RS-422 transmit differential pair.
8	COM2_RX+	COM2 receive data positive One half of the RS-422 receive differential pair.
9	EVENT_OUT1	EVENT1 (Mark1) output
10	EVENT_IN1	EVENT1 (Mark1) input
11	Reserved	Reserved
12	Reserved	Reserved

Pin	Signal name	Description
13	Reserved	Reserved
14	Reserved	Reserved
15	GND	Ground reference
16	VIN	Supply voltage input

Table 39: IO2 pinout

Pin	Signal name	Description
1	DMI_A+	Signal A+ from the Distance Measurement Instrument
2	ETH_RD+	Ethernet receive data positive One half of the Ethernet receive data differential pair.
3	CAN_H	CAN Bus port
4	USB_D+	One half of the USB differential pair.
5	DMI_A-	Signal A- from the Distance Measurement Instrument
6	ETH_TD-	Ethernet transmit data negative One half of the Ethernet receive data differential pair.
7	ETH_TD+	Ethernet transmit data positive One half of the Ethernet transmit data differential pair.
8	ETH_RD-	Ethernet receive data negative One half of the Ethernet transmit data differential pair.
9	EVENT_OUT2	EVENT2 (Mark2) output
10	EVENT_IN2	EVENT2 (Mark2) input
11	CAN_L	CAN Bus port
12	USB_D-	One half of the USB differential pair.
13	COM1_RX	COM1 receive data
14	COM1_TX	COM1 transmit data
15	GND	Ground reference
16	VIN	Supply voltage input

A.9 CPT7 I/O1 cable

The NovAtel part number for the CPT7 I/O1 cable is 01020697 (previously 01020208). The CPT7 I/O1 cable provides access to all of the signals available on the IO1 connector of the CPT7.



In the following diagram, the dimensions are in millimetres.

Figure 55: CPT7 I/O1 cable

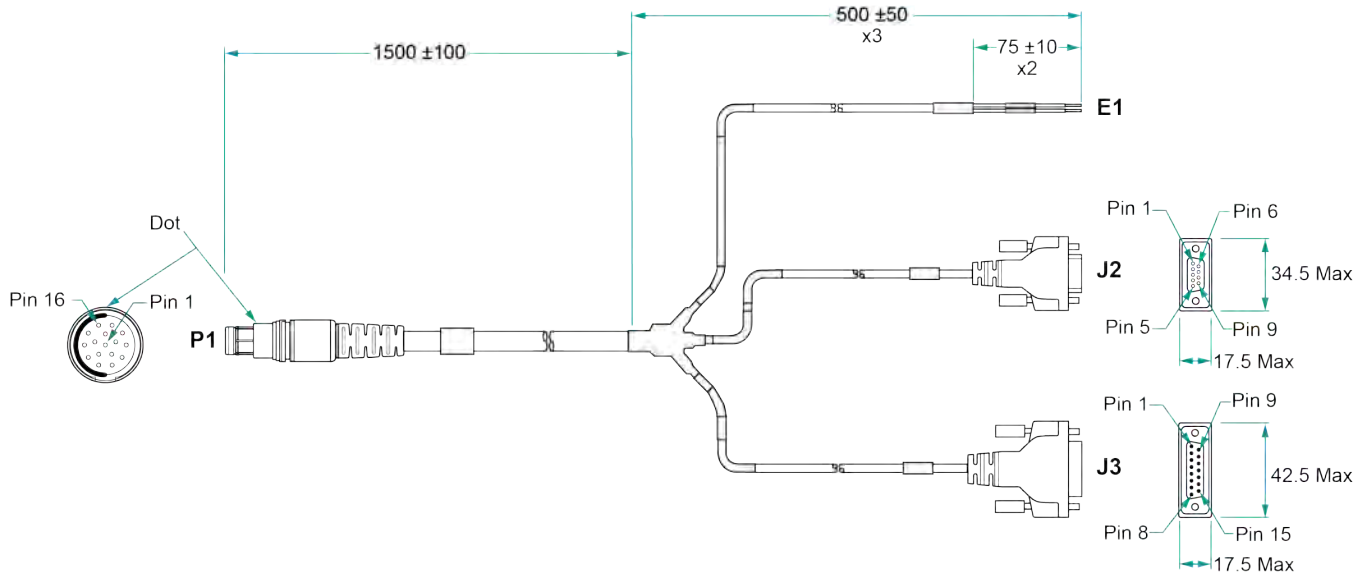

Table 40: CPT7 I/O1 cable pinout

P1 16 pin circular	Signal same	J2 COM 2 DB9 female	J3 AUX 1 DB15 female	E1 leads
1	EVENT_IN3		7	
2	COM2 RX-	7		
3	Reserved			
4	Reserved			
5	EVENT_OUT3		3	
6	COM2 TX-	8		
7	COM2 TX+	2		
8	COM2 RX+	3		
9	EVENT OUT1		10	
10	EVENT IN1		4	

P1 16 pin circular	Signal same	J2 COM 2 DB9 female	J3 AUX 1 DB15 female	E1 leads
11	Reserved			
12	Reserved			
13	Reserved			
14	Reserved			
15	GND	5	8	-VRTN
16	VIN			+VIN

A.9.1 Custom cable recommendations

To create a custom cable for the IO1 port, a specific connector is required on the CPT7 end of the cable. See the following table for information about this connector.

Table 41: I/O1 Connector

Connector	Description	Commercial part number	NovAtel part number
IO1	Fischer Core 16 pin cable mounted plug	SS 104 A086-140	21223365

A.10 CPT7 I/O2 cable

The NovAtel part number for the CPT7 I/O2 cable is 01020690 (previously 01020209). The CPT7 I/O2 cable provides access to all of the signals available on the IO2 connector on the CPT7.



In the following diagram, the dimensions are in millimetres.

Figure 56: CPT7 I/O2 cable

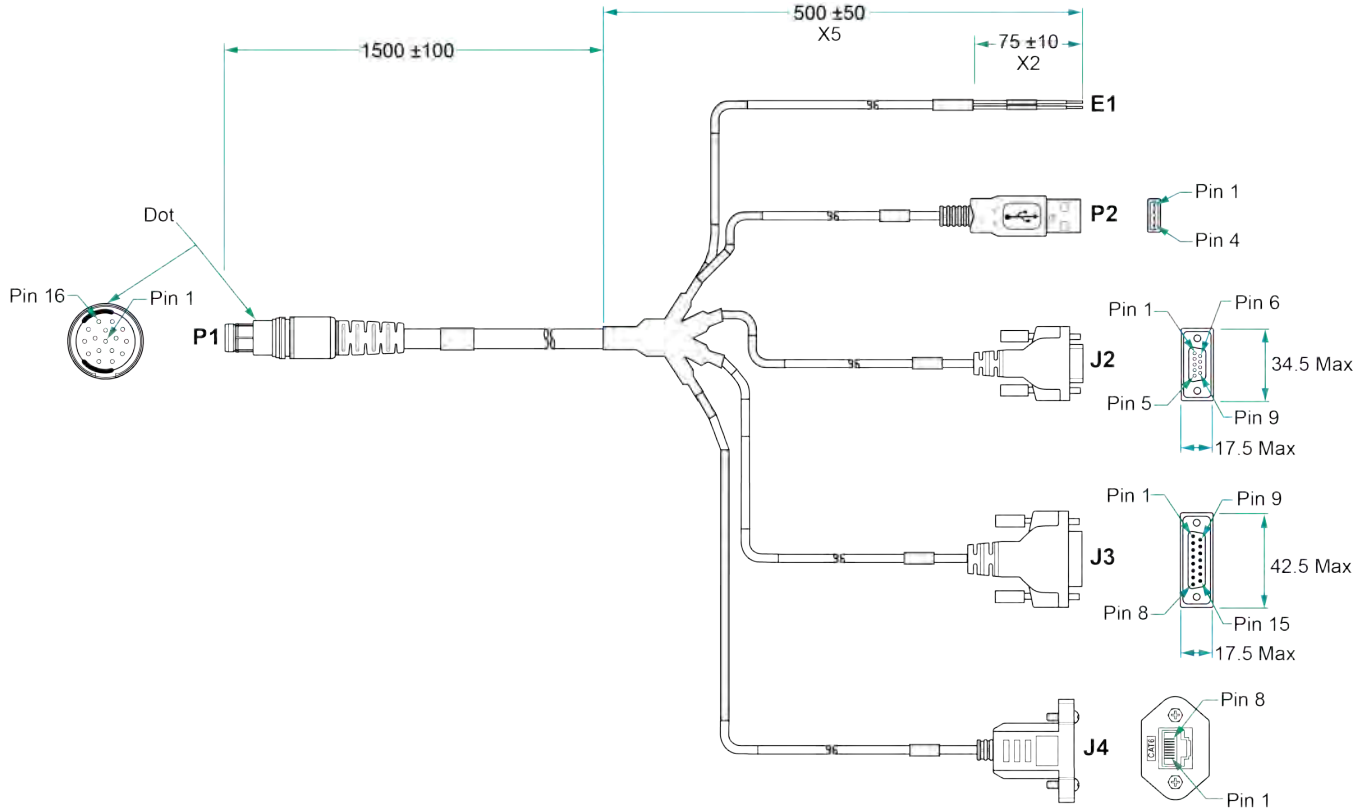

Table 42: CPT7 I/O2 cable pinout

P1 16 pin circular	Signal name	P2 USB type A male	J2 COM 1 DB9 female	J3 AUX 2 DB15 female	J4 Ethernet RJ45 female	Leads
1	DMI_A+			14		
2	ETH_RX_H				3	
3	CAN_H			1		
4	USB+	3				
5	DMI_A-			15		

P1 16 pin circular	Signal name	P2 USB type A male	J2 COM 1 DB9 female	J3 AUX 2 DB15 female	J4 Ethernet RJ45 female	Leads
6	ETH_TX_L				2	
7	ETH_TX_H				1	
8	ETH_RX_L				6	
9	EVENT_OUT2			9		
10	EVENT_IN2			6		
11	CAN_L			2		
12	USB-	2				
13	COM1_RXD		3			
14	COM1_TXD		2			
15	GND	4	5	8		-VRTN
16	+VIN					+VIN

A.10.1 Custom cable recommendations

To create a custom cable for the IO2 port, a specific connector is required on the CPT7 end of the cable. See the following table for information about this connector.

Table 43: IO2 connector

Connector	Description	Commercial part number	NovAtel part number
IO2	Fischer Core 16 pin cable mounted plug	SS 104 A086-240	21223366

Appendix B Differences between CPT7 and Legacy CPT7

The CPT7 has been updated to add new features. This section describes the differences between the updated CPT7 and the Legacy CPT7 receivers (PN 80023560).

Legacy CPT7 (PN 80023560)



CPT7



CPT7700



Table 44: Physical specifications

	Legacy CPT7	CPT7	CPT7700
Dimensions	90 x 76 x 60 mm	90 x 76 x 60 mm	90 x 76 x 60 mm
Weight	500 g	500 g	500 g
Status LEDs	–	4	4

Table 45: Power requirements

	Legacy CPT7	CPT7	CPT7700
Input Voltage	9 to 32 VDC	9 to 36 VDC	9 to 36 VDC
Power Consumption	7 W	9 W	9 W

Table 46: Signals tracked

		Legacy CPT7	CPT7	CPT7700
GPS	L1 C/A	Y	Y	Y
	L1C	Y	Y	Y
	L2C	Y	Y	Y
	L2P	Y	Y	Y
	L5	Y	Y	Y

		Legacy CPT7	CPT7	CPT7700
GLONASS	L1 C/A	Y	Y	Y
	L2 C/A	Y	Y	Y
	L2P	Y	Y	Y
	L3	Y	Y	Y
Galileo	E1	Y	Y	Y
	E5a	Y	Y	Y
	E5b	Y	Y	Y
	E5 AltBOC	Y	Y	Y
	E6	–	–	Y
BeiDou	B1I	Y	Y	Y
	B1C	Y	Y	Y
	B2I	Y	Y	Y
	B2a	Y	Y	Y
	B2b	Y	Y	Y
	B3I	–	–	Y
QZSS	L1 C/A	Y	Y	Y
	L1C	Y	Y	Y
	L2C	Y	Y	Y
	L5	Y	Y	Y
	L6	–	–	Y
NavIC	L5	Y	Y	Y
SBAS	L1	Y	Y	Y
	L5	Y	Y	Y

Table 47: RF input

		Legacy CPT7	CPT7	CPT7700
GNSS Antenna Connector	Primary	SMA	SMA	SMA
	Secondary	SMA	SMA	–
LNA	Primary	+5 VDC ±5%; 200 mA	+5 VDC ±5%; 200 mA	+5 VDC ±5%; 200 mA
	Secondary	+5 VDC ±5%; 200 mA	+5 VDC ±5%; 200 mA	–

Table 48: COM port communication

	Legacy CPT7	CPT7 and CPT7700
COM1 Data Rate	2400, 4800, 9600 (default), 19200, 38400, 57600, 115200 or 230400 bit/s	2400, 4800, 9600 (default), 19200, 38400, 57600, 115200, 230400 or 460800 bit/s

Table 49: I/O strobes

	Legacy CPT7	CPT7	CPT7700
Event In	2	3	3
Event Out	2	3	3
Wheel Sensor	–	1	1

Table 50: Features

	Legacy CPT7	CPT7	CPT7700
INS solution	200 Hz	200 Hz	200 Hz
IMU raw data rate	100 Hz	100 Hz or 400 Hz*	100 Hz or 400 Hz*
Onboard Memory	–	16 GB	16 GB
*Configurable with appropriate model.			

Appendix C Accessories and replacement parts

The following tables list the replacement parts available for your NovAtel OEM7 receiver. For assistance or to order additional components, contact your local NovAtel dealer or Customer Support.

Table 51: OEM7 receivers

NovAtel part	Description
OEM719	OEM7 receiver card with OEM6 compatible 20 pin header
OEM729	OEM7 receiver card with OEM6 compatible 24 pin and 16 pin headers
OEM7600	OEM7 receiver card with high density 60 pin socket and small form factor
OEM7700	OEM7 receiver card with high density 60 pin socket
OEM7720	OEM7 receiver card with dual antenna inputs and high density 60 pin socket
PwrPak7	OEM7 enclosure with Wi-Fi and built in data storage
PwrPak7D	Dual antenna OEM7 enclosure with Wi-Fi and built-in data storage
PwrPak7-E1	Single enclosure SPAN GNSS+INS receiver with EG320N IMU, Wi-Fi and built-in data storage
PwrPak7D-E1	Single enclosure SPAN GNSS+INS receiver with dual antenna inputs, EG320N IMU, Wi-Fi and built-in data storage
PwrPak7-E2	Single enclosure SPAN GNSS+INS receiver with EG370N IMU, Wi-Fi and built-in data storage
PwrPak7D-E2	Single enclosure SPAN GNSS+INS receiver with dual antenna inputs, EG370N IMU, Wi-Fi and built-in data storage
PwrPak7M	OEM7 enclosure (no Wi-Fi or data storage)
PwrPak7DM	Dual antenna OEM7 enclosure (no Wi-Fi or data storage)
PwrPak7M-E1	Single enclosure SPAN GNSS+INS receiver with an EG320N IMU (no Wi-Fi or data storage)
PwrPak7DM-E1	Single enclosure SPAN GNSS+INS receiver with dual antenna inputs and EG320N IMU (no Wi-Fi or data storage)
PwrPak7M-E2	Single enclosure SPAN GNSS+INS receiver with an EG370N IMU (no Wi-Fi or data storage)
PwrPak7DM-E2	Single enclosure SPAN GNSS+INS receiver with dual antenna inputs and EG370N IMU (no Wi-Fi or data storage)
PwrPak7Q-E2	Single enclosure SPAN GNSS+INS receiver with EG370N IMU and built-in data storage (no Wi-Fi)
PwrPak7DQ-E2	Single enclosure SPAN GNSS+INS receiver with dual antenna inputs, EG370N IMU and built-in data storage (no Wi-Fi)
CPT7	Single enclosure SPAN GNSS+INS receiver with dual antenna inputs, HG4930 IMU and built-in data storage
CPT7700	Single enclosure SPAN GNSS+INS receiver with HG4930 IMU and built-in data storage

Table 52: GNSS antennas

NovAtel part	Description
High performance antennas	
GNSS 502	GPS L1/L2, GLONASS L1/L2, BeiDou B1/B2b, Galileo E1/E5b, QZSS L1/L2, L-band
GNSS-503	GPS L1/L2/L5, GLONASS L1/L2, BeiDou B1/B2a/B2b, Galileo E1/E5a/E5b/E6, QZSS L1/L2/L5, NavIC L5, L-band
GNSS-802	GPS L1/L2, GLONASS L1/L2, BeiDou B1, Galileo E1, QZSS L1/L2
GNSS-802L	GPS L1/L2, GLONASS L1/L2, BeiDou B1, Galileo E1, QZSS L1/L2, L-band
GNSS-804	GPS L1/L2, GLONASS L1/L2, BeiDou B1/B2I/B2b, Galileo E1/E5b, QZSS L1/L2
GNSS-804L	GPS L1/L2, GLONASS L1/L2, BeiDou B1/B2I/B2b, Galileo E1/E5b, QZSS L1/L2, L-band
GNSS-850	GPS L1/L2/L5, GLONASS L1/L2/L3, BeiDou B1/B2I/B2a/B2b/B3, Galileo E1/E5a/E5b/E6, QZSS L1/L2/L5/L6, NavIC L5, L-band
Compact antennas	
2G15A-XTB-1	2.6" circular form factor (GPS L1)
3G15A-XT-1	3.5" circular form factor (GPS L1)
3GNSSA-XT-1	3.5" circular form factor (GPS L1/L2/L5, GLONASS L1/L2, BeiDou B1/B2a/B2b, Galileo E1/E5a/E5b, QZSS L1/L2/L3, NavIC L5, L-band)
42G1215A-XT-1	ARINC-743 bolt pattern (GPS L1/L2)
42GNSSA-XT-1	ARINC-743 bolt pattern (GPS L1/L2/L5, GLONASS L1/L2, BeiDou B1/B2a/B2b, Galileo E1/E5a/E5b, QZSS L1/L2/L3, NavIC L5, L-band)
G3Ant-2A196MNS-4	2.7" circular form factor (GPS L1, GLONASS L1, BeiDou B1, Galileo E1 and L-band)
G3Ant-42A4T1	ARINC-743 bolt pattern (GPS L1, GLONASS L1, BeiDou B1, Galileo E1, L-band)
G3Ant-4AT1	Mini-ARINC pattern (GPS L1, GLONASS L1, Galileo E1, BeiDou B1, L-band)
G5Ant-3AMT1	3.5" circular form factor (GPS L1/L2, GLONASS L1/I2, BeiDou B1/B2a, Galileo E1/E5a, L-band)
G5Ant-3AT1	3.5" circular form factor (GPS L1/L2, GLONASS L1/I2, BeiDou B1, Galileo E1, L-band)
G5Ant-42AT1	ARINC-743 bolt pattern (GPS L1/L2, GLONASS L1/L2, BeiDou B1, Galileo E1, L-band)
G5Ant-42AT1-A	ARINC-743 bolt pattern (GPS L1/L2, GLONASS L1/I2, BeiDou B1/B2a, Galileo E1/E5a, L-band)

Table 53: CPT7 cables

NovAtel part	Description
01020208	CPT7 I/O1 Cable
01020209	CPT7 I/O2 Cable
01020697	CPT7 I/O1 Cable
01020690	CPT7 I/O2 Cable
21223365	Fischer Core Series cable mounted plug. For use on cables made for the CPT7 IO1 connector. Fischer part number: SS 104 A086-140
21223366	Fischer Core Series cable mounted plug. For use on cables made for the CPT7 IO2 connector. Fischer part number: SS 104 A086-240

Table 54: GNSS antenna cables

NovAtel part	Description
GPS-C006	5 metres – TNC to TNC cable
GPS-C016	15 metres – TNC to TNC cable
GPS-C032	30 metres – TNC to TNC cable
60723177	2.5 metres – SMA to TNC cable
60723178	5 metres – SMA to TNC cable

Table 55: CPT7 mounting accessories

NovAtel part	Description
01020112	CPT7 Adapter Plate Kit

Appendix D Frequently asked questions

1. What is the minimum configuration I need to do to get the system running?
 - a. Specify the translational offset between the IMU centre of navigation and the primary GNSS antenna phase centre with the **SETINSTRANSLATION** command.
 - b. Specify the rotational offset between the IMU Body frame and the Vehicle frame, with the **SETINSROTATION** command.
2. Why don't I have any INS data?
 - a. By default, the raw IMU data begins flowing at system start up. If there is no INS data, check that the system has been configured properly.
 - b. If the **INSCOMMAND** command has been set to **START_FINE_TIME**, the RAWIMU logs are not available until the system has solved for time. This requires that an antenna is attached and satellites are visible to the system. You can verify that time is solved by checking the time status in the header of any standard header log such as BESTPOS. When the time status reaches FINETIME, the inertial filter starts and IMU data is available.
3. How can I access the inertial solution?

The GNSS+INS solution is available from a number of specific logs dedicated to the inertial filter. The **INSPOS** log, **INSPVA** log, **INSVEL** log, **INSSPD** log and **INSATT** log are the most commonly used logs for extracting the INS solution. These logs can be logged at any rate up to the rate of the IMU data (100 or 400 Hz). The solution can also be triggered by the mark input signal by requesting the **MARKxPVA** logs.
4. Can I still access the GNSS-only solution while running SPAN?

The GNSS only solution used when running the OEM7 receiver without the IMU is still available when running SPAN. Logs such as the **PSRPOS** log and **RTKPOS** log are still available. The **BESTGNSSPOS** log is also available to provide the best available GNSS only solution. To manage processor load, any non-INS logs should be logged at a maximum rate of 5 Hz when running SPAN. Only INS-specific logs should be logged at rates higher than 5 Hz when running SPAN.
5. What will happen to the INS solution when I lose GNSS satellite visibility?

When GNSS tracking is interrupted, the INS solution bridges through the gaps with what is referred to as free-inertial navigation. The IMU measurements are used to propagate the solution. Errors in the IMU measurements accumulate over time to degrade the solution accuracy. For example, after one minute of GNSS outage, the horizontal position accuracy is approximately 2.5 m when using an HG1700 AG58. The SPAN solution continues to be computed for as long as the GNSS outage lasts, but the solution uncertainty increases with time. This uncertainty can be monitored using the **INSSTDEV** log or **INSSTDEVS** log.



Further details on the command and logs in this section are available in the [OEM7 Commands and Logs Reference Manual](#).

Appendix E Importance of antenna selection

An antenna behaves both as a spatial and frequency filter, therefore, selecting the right GNSS antenna is critical for optimizing performance. An antenna must match the receiver's capabilities and specifications, as well as meet size, weight, environmental and mechanical specifications for the intended application.

Factors to consider when choosing a GNSS antenna include:

1. Constellation and signals

Each GNSS constellation and SBAS has its own signal frequencies and bandwidths. An antenna must cover the signal frequencies transmitted by the constellation and bandwidth supported by the GNSS receiver.

2. Antenna gain

Gain is a key performance indicator of a GNSS antenna. Gain can be defined as the relative measure of an antenna's ability to direct or concentrate radio frequency energy in a particular direction or pattern. A minimum gain is required to achieve a minimum carrier-to-power-noise ratio (C/No) to track GNSS satellites. The antenna gain is directly related to the overall C/No of the navigation GNSS receivers. Hence, antenna gain helps define the tracking ability of the system.

3. Element Gain

The element gain defines how efficient the antenna element is at receiving the signals. In any signal chain, you are only as good as the weakest link, so an antenna element with low element gain might be compensated by an increased low noise amplifier gain. However, the signal-to-noise ratio or C/No is still degraded.

4. Antenna beamwidth and gain roll-off

Gain roll-off is a factor of beamwidth, and specifies how much the gain changes over the elevation angle of the antenna. From the antenna's point of view, the satellites rise from the horizon towards zenith and fall back to the horizon. The variation in gain between zenith (directly overhead) and the horizon is known as the gain roll-off. Different antenna technologies have different gain roll-off characteristics.

5. Phase centre stability

The phase centre of the antenna is the point where the signals transmitted from satellites are collected. When a receiver reports a location fix, that location is essentially the phase centre of the antenna.

The electrical phase centre of any antenna will vary with the position of the transmitting signal it is receiving by as much as a few millimetres. As GNSS satellites move across the sky, the electrical phase centre of the signal received will typically move with the satellite position unless the antenna has been carefully designed to minimize Phase Centre Offset (PCO) and Phase Centre Variation (PCV).

The PCO with respect to the Antenna Reference Point (ARP) is the difference between the mechanical centre of antenna rotation and electrical phase centre location. The PCO is also frequency dependent which means that there can be a different offset for each signal frequency. The PCV identifies how much the phase centre moves with respect to the satellite elevation angles.

Figure 57: Plot of good and poor antenna phase centre variation over elevation angle 0-90°

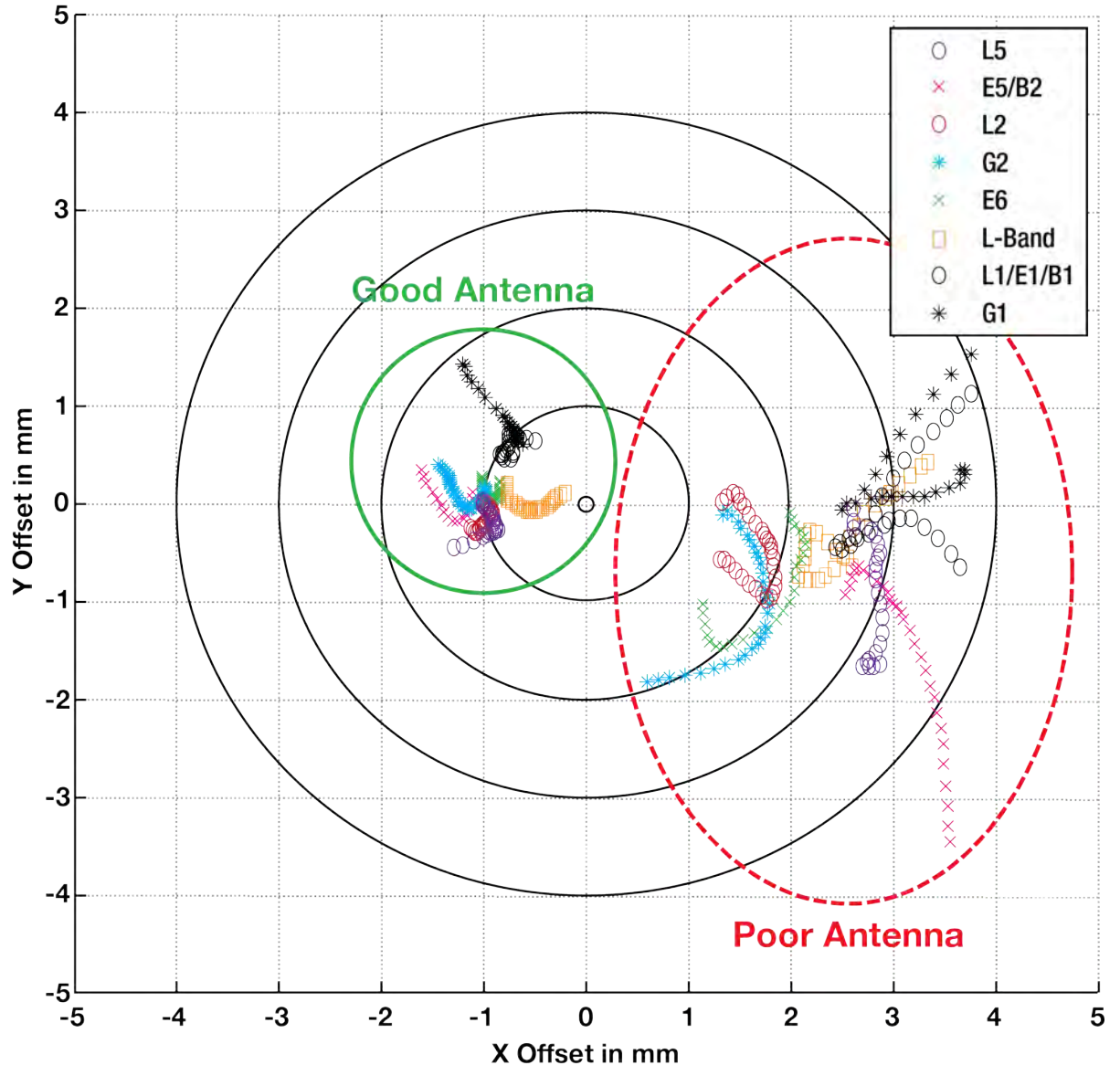

Many users can accept accuracies of less than a metre so these small phase centre variations cause a negligible amount of position error. But if you require high precision, Real Time Kinematic (RTK) receivers can achieve position accuracies of 2-4 cm and a few millimetres of phase centre error translates to a 10-15% error in reported position. For RTK survey applications, geodetic grade antennas offer superior PCO/PCV performance.

6. The application

An antenna has to meet the performance, environmental, mechanical, and operational requirements of the intended application. For example, GNSS antennas used for aviation applications should ideally be TSO/FAA certified and be rugged enough to handle extreme temperatures and vibration profiles. Survey rover antennas should be able to survive rough handling by surveyors including a pole drop.

The table below highlights some of the important desirable features needed for a GNSS antenna based upon the user's application.

Desirable Feature	Survey	GIS	Reference Station	Aviation/Aerial Survey	Marine	Construction/Mining	Precision Agriculture	Vehicle Tracking	Dock Operations	Unmanned Aircraft	Unmanned Vehicle	Timing
Low Profile				•		•		•		•		
Ultra-low PCO/PCV	•		•									
Low PCO/PCV		•		•		•	•			•	•	
High Vibration				•		•	•		•	•	•	
Rugged	•	•	•			•			•			
Single Frequency												•
Multi Constellation	•	•	•	•	•	•	•		•	•	•	
Multi Frequency (RTK)	•	•	•		•	•	•		•	•	•	
L-band frequency (Correction Services)					•		•					
Narrow Bandwidth												•
Weatherproof	•	•	•	•	•	•	•	•	•	•	•	•
Corrosion Resistant			•		•	•			•			•
High Multipath Suppression	•		•		•	•	•		•		•	
Pole Mount	•	•	•		•	•			•			•
Magnetic/Surface Mount						•	•	•	•		•	
TSO/FAA Certification				•						•		
Extended Temperature Range			•	•						•		
Small Form-factor/ Lightweight		•								•		
High Altitude Operation			•	•						•		

